

No Bootstrap Spaceships

Kirk T. McDonald

Joseph Henry Laboratories, Princeton University, Princeton, NJ 08544

(August 9, 2018; updated February 5, 2020)

1 Introduction

A **bootstrap spaceship** is an isolated, self-propelled device that does not emit any matter or radiation.^{1,2} That is, the center of mass/energy of such a device could accelerate without application of any “external” force, or consumption of any internal propellant that is somehow exhausted.

This note concerns devices that combine matter and electromagnetic fields. Some comments on all-mechanical devices are in Appendix B below, and a survey of imagined electromagnetic devices is given in Appendix C.

While most people consider that “bootstrap spaceships” are impossible, a persistent minority argues that they can exist.³

1.1 The Center-of-Energy Theorem

A reason why there are no “bootstrap spaceships” is given by the so-called center-of-energy theorem,⁴ that the total linear momentum of any isolated, stationary system is zero if the velocity of its center of mass/energy is zero.

Consider an isolated, system which is a candidate for a “bootstrap spaceship”, and is initially stationary. According to the center-of-energy theorem it has zero total linear momentum.

At some time, the system could initiate internal activity that generates quasistatic electromagnetic-field momentum which is not radiated away, but which remains in the vicinity of the matter of the system. For the total momentum of the system to remain zero, there must now be some mechanical momentum in the system. Nominally, such mechanical momentum would imply that the center of mass of the matter of the system is in motion, and would be propelled in some direction.

At a later time, suppose the system stops its internal activity, such that the equal-and-opposite electromagnetic-field momentum and mechanical momentum are constant thereafter. The center of mass of the matter of the system then has a constant velocity in some direction.

If we observe the system in the (inertial) frame with that constant velocity, the system is isolated and stationary. So, according to the center-of energy theorem, the total momentum of the system should be zero in this frame. However, while the mechanical momentum of the system is zero in this frame, its electromagnetic-field momentum is nonzero, and hence the

¹The term “bootstrap spaceship” was perhaps first used on p. 612 of [69]. See also [83].

²A “bootstrap spaceship” would operate via a “reactionless drive”,
https://en.wikipedia.org/wiki/Reactionless_drive

³Recent examples are [131, 180, 201, 203, 204, 205, 209, 214].

⁴See the Appendix of [52], sec. 2 of [66], and sec. I of [70]. See also Appendix A below.

total momentum of the system is nonzero (in this frame). This contradiction implies that the above scenario is impossible.

1.2 “Hidden” Mechanical Momentum

The resolution of this “paradox” is that if an isolated, stationary system contains nonzero electromagnetic field momentum, the equal-and-opposite mechanical (linear) momentum is not “overt”, but rather is “hidden”.⁵ If an isolated system, that is initially stationary, develops some electromagnetic-field momentum which is not radiated away, the equal-and-opposite (linear) mechanical momentum is **not** associated with motion of the center of mass of the matter of the system, but rather is “hidden”. In Shockley’s example, a net momentum is “hidden” in the electrical currents that generate the magnetic field required so that there can be nonzero electromagnetic field momentum.⁶

Versions of this argument have been given since the 1960’s, as will be reviewed in Appendix C below, but some people refuse to acknowledge the validity of the center-of-energy theorem, or that “hidden” mechanical momentum can exist, such that they claim what we have called a “bootstrap spaceship” is possible.⁷

A Appendix: Center-of-Energy Theorem

The mechanical behavior of a macroscopic system can be described with the aid of the (symmetric) stress-energy-momentum tensor $T^{\mu\nu}$ of the system. The total energy-momentum 4-vector of the system is given by,

$$U^\mu = (U_{\text{total}}, P_{\text{total}}^i c) = \int T^{0\mu} d\text{Vol}. \quad (1)$$

As first noted by Abraham [23], at the microscopic level the electromagnetic parts of $T^{\mu\nu}$ are,

$$T_{\text{EM}}^{00} = \frac{E^2 + B^2}{8\pi} = u_{\text{EM}}, \quad (2)$$

$$T_{\text{EM}}^{0i} = \frac{S^i}{c} = p_{\text{EM}}^i c, \quad (3)$$

$$T_{\text{EM}}^{ij} = \frac{E^i E^j + B^i B^j}{4\pi} - \delta^{ij} \frac{E^2 + B^2}{8\pi}, \quad (4)$$

in terms of the microscopic fields \mathbf{E} and \mathbf{B} . In particular, the density of electromagnetic momentum stored in the electromagnetic field is,

$$\mathbf{p}_{\text{EM}} = \frac{\mathbf{S}}{c^2} = \frac{\mathbf{E} \times \mathbf{B}}{4\pi c}. \quad (5)$$

⁵The term **hidden momentum** was introduced by Shockley (1967) [63].

⁶For an example in which the “hidden” mechanical momentum is more abstractly related by $\mathbf{P}_{\text{hid,mech}} = \mathbf{P}_{\text{mech}} - m_{\text{mech}} \mathbf{v}_{\text{cm,mech}} = -m_{\text{mech}} \mathbf{v}_{\text{cm,mech}}$, see sec. 2.4 of [123].

⁷Recent arguments against the center-of-mass theorem and “hidden momentum”, while being in favor of “bootstrap spaceships”, include [180, 209] and [204, 205].

The macroscopic stress tensor $T^{\mu\nu}$ also includes the “mechanical” stresses within the system, which are actually electromagnetic at the atomic level. The form (4) still holds in terms of the macroscopic fields \mathbf{E} and \mathbf{B} in media where $\epsilon = 1 = \mu$ such that stricitive effects can be neglected. The macroscopic stresses T^{ij} are related the volume density \mathbf{f} of force on the system according to,

$$f^i = \frac{\partial T^{ij}}{\partial x^j}. \quad (6)$$

The stress tensor $T^{\mu\nu}$ obeys the conservation law,

$$\frac{\partial T^{\mu\nu}}{\partial x_\mu} = 0, \quad (7)$$

with $x^\mu = (ct, \mathbf{x})$ and $x_\mu = (ct, -\mathbf{x})$. Once consequence of this is that the total momentum is constant for an isolated, spatially bounded system, *i.e.*,

$$\int \frac{\partial T^{\mu i}}{\partial x_\mu} = 0 = \frac{\partial}{\partial ct} \int T^{0i} d\text{Vol} - \int \frac{\partial T^{ji}}{\partial x^j} d\text{Vol} = \frac{dP_{\text{total}}^i}{dt} - \int T^{ji} d\text{Area}^j = \frac{dP_{\text{total}}^i}{dt}. \quad (8)$$

A related result is that the total (relativistic) momentum $\mathbf{P}_{\text{total}}$ of an isolated system is proportional to the velocity $\mathbf{v}_U = d\mathbf{x}_U/dt$ of the center of mass/energy of the system [52, 66, 70],

$$\mathbf{P}_{\text{total}} = \frac{U_{\text{total}}}{c^2} \mathbf{v}_U = \frac{U_{\text{total}}}{c^2} \frac{d\mathbf{x}_U}{dt}, \quad (9)$$

where,

$$U_{\text{total}} = \int T^{00} d\text{Vol}, \quad (10)$$

$$P_{\text{total}}^i = \frac{1}{c} \int T^{0i} d\text{Vol}, \quad (11)$$

$$\mathbf{x}_U = \frac{1}{U_{\text{total}}} \int T^{00} \mathbf{x} d\text{Vol}. \quad (12)$$

That is, the total momentum of an isolated system is zero in that (inertial) frame in which the center of mass/energy is at rest.

B Appendix: Mechanical Bootstrap Spaceships

There exist numerous suggestions for all-mechanical bootstrap spaceships, although, of course, none has ever been demonstrated to work. An overview of these is given in [150] (see also [161]), which emphasizes two types of devices, *oscillation thrusters* such as [43], and *gyroscopic antigravity* such as [107] and the many variants reported at <http://www.gyrosopes.org>.

These suggestions generally came from outside the academic community, but an exception is Laithwaite, who in 1974 interpreted his experiments with gyroscopes as evidence for both a bootstrap spaceship [71, 107], and antigravity [75]. He gave a famous set of lectures at the Royal Institution in 1974 [73, 183] illustrating the counterintuitive behavior of gyroscopes, perhaps hoping to lead the audience to his interpretation that the demonstrations could not be explained by Newton’s laws. He was unable to get his views published in mainstream academic journals, but did publish a few “popular science” articles [72, 74, 75, 79, 82].

C Appendix: History of Electromagnetic Bootstrap Spaceships

C.1 Electrostatic and Magnetostatic Repulsion

An electric charge exerts a repulsive force on another like charge (and a “pole” of a magnet exerts a repulsive force on a like “pole” of another magnet). Such a system is not a bootstrap spaceship in that the center of mass of an isolated pair of like charges would remain at rest as the two charges move away from one another.

C.2 Ampère

After the discovery by Oersted [3, 4] that an electric current can exert a force on a permanent magnet, the possibility of electromagnetic “spaceships” arose. In 1822, Ampère and de la Rive [6] demonstrated an intriguing effect of a bent wire (“hairpin”) whose two “legs” floated in separate trough of mercury, such that when the latter were connected to a battery the “hairpin” was propelled along the troughs, as sketched below.

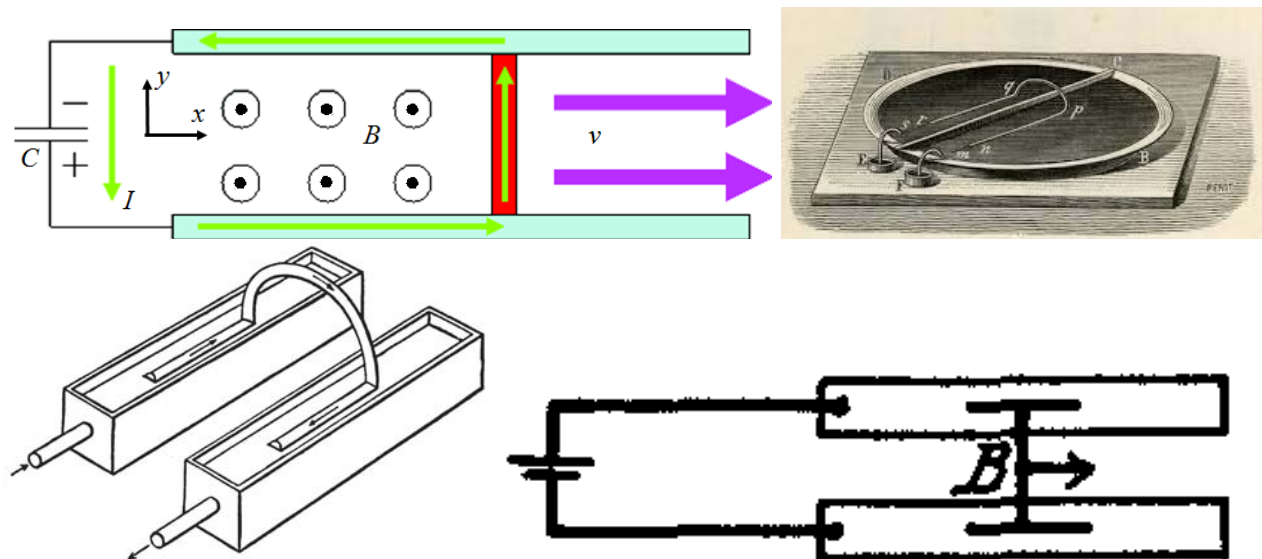

The figure on the lower left above is from Art. 687 of Maxwell’s *Treatise* [13], and the figure on the lower right is from Hering [31].

Ampère considered that this demonstration supported his theory of magnetic forces, in which collinear current elements with the same sense repel one another. The present view, based on the so-called Biot-Savart-Lorentz force law, $d\mathbf{F} = I d\mathbf{l} \times \mathbf{B}/c$ predicts that the force on the crosspiece of the “hairpin” is largely due to the magnetic field of the currents in the portions of the “hairpin” in the mercury troughs.⁸ This explanation indicates that “magnetic forces can do work”, and that the motion of the “hairpin” is due to a force of one portion of the “hairpin” on another.

⁸In Art. 687 of [13], Maxwell remarked that Ampère’s experiment involves a closed circuit, and so cannot distinguish between Ampère’s force law and that of Biot-Savart-Lorentz (which Maxwell attributed to Grassmann [10]).

The latter effect suggests that Ampère’s device is a “bootstrap spaceship”, which bothers many people,⁹ some of whom argue that the Lorentz force law is wrong, and Ampère’s original force law is the correct one. This saga is reviewed by the author in [199].

The author’s view is that the Lorentz force law is valid, and that Ampère’s device is not a “bootstrap spaceship” in that the force on the crosspiece of the “hairpin” is due to the electric current in the other portions of the “hairpin”, which current is not strictly an aspect of the “hairpin” as a rigid body, but is an aspect of the larger electric circuit. That is, the “hairpin” considered as a rigid body does not exert a force on itself

Ampère’s experiment was the precursor of the electromagnetic railgun, on which the literature is now vast.¹⁰

C.3 Thomson

The earliest discussion of a possible bootstrap spaceship was by J.J. Thomson (1904) [25].¹¹

C.3.1 Electric Charge + Magnetic Monopole

Thomson considered the electromagnetic field momentum, $\mathbf{P}_E = \int \mathbf{E} \times \mathbf{B} d\text{Vol}/4\pi c$ in Gaussian units,¹² of an electric charge q and a (Gilbertian) magnetic (mono)pole p , both at rest, and found this to be zero on p. 333 of [25].

C.3.2 Electric Charge + Gilbertian Magnetic Dipole

On p. 334 Thomson noted that the field momentum of a single electric charge and any number of magnetic poles is also zero, which includes the case of an electric charge and a (Gilbertian) magnetic dipole \mathbf{m} .

C.3.3 Electric Charge + Ampèrian Magnetic Dipole

On p. 347 of [25], Thomson noted that the external magnetic field of a Gilbertian magnetic dipole is the same as that of an Ampèrian dipole, so the field momentum of the latter (in the presence of an electric charge) is just the momentum associated with the “interior” of the dipole. If the magnetic dipole is realized by a coil of area A and length l with N turns that carry current I , then the interior axial field is $B_{\text{in}} \approx (4\pi/c)NI/l = (4\pi/c)NIA/\text{Vol}_{\text{coil}} = 4\pi m/\text{Vol}_{\text{coil}}$, where the magnetic moment of the coil is $m = NIA/c$. Hence, the field mo-

⁹Ampère would not have considered his device to be a “bootstrap spaceship”. In the 20th century, Ampère’s force law was championed most notably by Hering [31] and by Graneau [87].

¹⁰A railgun was patented by Birkeland in 1902 [22]. A sample of two more recent articles on railguns is [78, 166].

¹¹This paper is also notable for containing the first recognition that the electromagnetic field could carry angular momentum. See also [185, 196].

¹²Thomson had invented the concept of electromagnetic field momentum in 1891 [18], and related it to the Poynting vector [17] on p. 9 of [19].

mentum inside the coil (and also the total field momentum of the system) is,¹³

$$\mathbf{P}_{EM} = \frac{\mathbf{E} \times \mathbf{B}_{in} \text{Vol}_{coil}}{4\pi c} = \frac{\mathbf{E} \times \mathbf{m}}{c}, \quad (13)$$

where \mathbf{E} is the electric field of charge q at the magnetic dipole \mathbf{m} .

In the figure below, from [25], the electric charge is at P , and the small solenoid is AB.

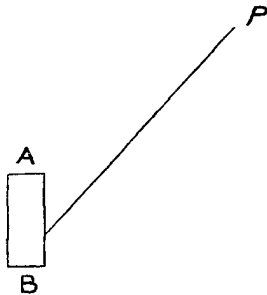

On p. 348 of [25] Thomson argued that the field momentum is associated with the electric charge, and that if the Ampèrian magnetic dipole were a small permanent magnet (in the field of an electric charge), and this magnet were demagnetized by “tapping”, the electric charge would acquire the initial field momentum (13).

That is, Thomson’s argument, if correct, would imply that the system of an electric charge and a small magnet is a “bootstrap spaceship”.

C.3.4 Trammel

Thomson’s example of a charge plus (long) solenoid magnet was considered (without reference to Thomson) by Aharonov and Bohm (1959) in their well-known paper [45]. This led Trammel (1964) [49] to remark that while the magnet exerts negligible force on the (moving) charge (if the charge remains always outside the magnet),¹⁴ the charge exerts a force on the magnet. That is, this system appears to be a kind of “bootstrap spaceship”.

The paper of Trammel may have been the immediate cause of the effort in the mid 1960’s that led to the concept of “hidden” mechanical momentum.

C.3.5 Calkin

Thomson’s example was considered in 1966 by Calkin [58] (who attributed it to Cullwick, sec. C.6 below, rather than to Thomson), in a manner that supposed it to be a “bootstrap spaceship”.¹⁵

In 1970, Calkin [70] discussed “hidden” mechanical momentum in such examples, with the implication that Thomson’s example is not a “bootstrap spaceship”.

¹³The difference between the magnetic fields of “point” Ampèrian and Gilbertian magnetic dipoles is $4\pi \mathbf{m} \delta^3(\mathbf{r})$ (see, for example, sec. 5.6 of [117]), which also leads to eq. (13).

¹⁴A “paradox” involving a charge that somehow passes through the coil of an infinite solenoid was posed in [53], and discussed in [57, 61, 141].

¹⁵Trammel and Calkin discussed an “infinite” solenoid, which has certain delicacies that must be treated with care. See, for example [192].

C.4 Brown

In the 1920's, Brown [35] claimed that a system of two electrodes with an electrostatic potential difference exerted a self force in the direction from the larger electrode to the smaller, if they were not the same size. Despite a general consensus that the force is due to corona discharge (“ion wind”)¹⁶ [124, 127, 136, 181, 182, 184, 163, 191, 217], and hence is not a self force, papers continue to be published arguing that the phenomenon includes a small self force [132, 198].

The claims of self propulsion by an asymmetric rf cavity, sec. C.13 below, are a variant on this theme.

C.5 Slepian

In the late 1940's J. Slepian, a senior engineer at Westinghouse, posed a series of delightful pedagogic puzzles in the popular journal *Electrical Engineering*. One of these concerned how a capacitor in a cylindrical magnetic field might or might not be used to provide a form of rocket propulsion [39].

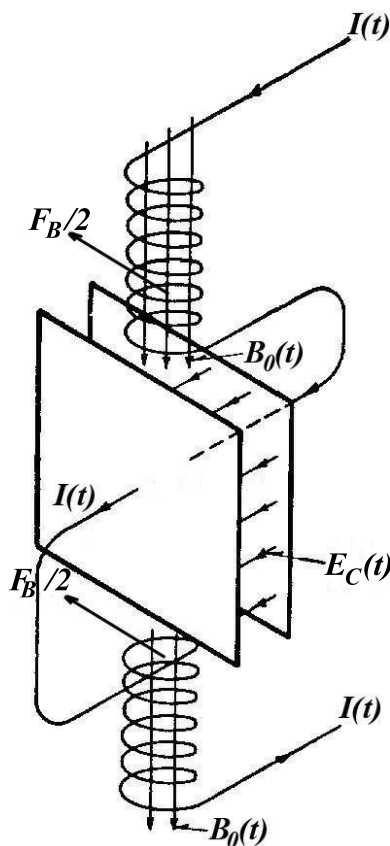

¹⁶That electrified objects can emit a kind of “wind” was perhaps first noted in 1709 by Hauksbee, pp. 46-47 of [1], and these *electric vapours* were briefly discussed by Newton, p. 315 of [2]. This phenomenon was called the *brush discharge* by Faraday [9].

For a historical review, see [47]. Propulsion by ions in static electromagnetic fields finds application in some satellites. See, for example, [60, 154].

The current in Slepian’s example is sinusoidal at a low enough frequency that radiation is negligible, so that system can be regarded as quasistatic. In this case, the electromagnetic field momentum is always equal and opposite to the “hidden” mechanical momentum, according to a general result of sec. 4.1.4 of [174]. Consequently, the Lorentz force on the system associated with the \mathbf{E} and \mathbf{B} field induced by the oscillating \mathbf{B} and \mathbf{E} fields are always equal and opposite to the “hidden” momentum forces associated with the oscillatory “hidden” momentum, and the total momentum of the system remains constant (no rocket propulsion).¹⁷

C.6 Cullwick

Cullwick (1952) [41, 44] noted that an electric charge moving along the axis of a constant-current toroidal coil is paradoxical because no force is exerted on the moving charge,¹⁸ but the moving charge exerts a nonzero force on the toroid.¹⁹

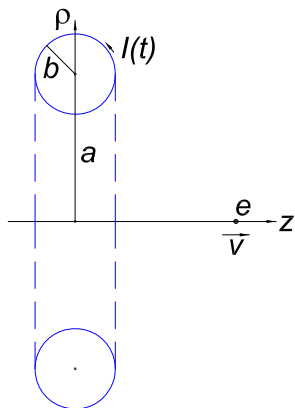

In the quasistatic limit, Cullwick’s paradox is resolved by noting that the unbalanced force is equal and opposite to the time rate of change of the field momentum [144].

For a “spaceship” based on Cullwick’s paradox, suppose the toroid and the electric charge form an isolated system. Initially the electric charge is at rest at a nonzero value of z along the axis of the toroid, which latter supports an initially steady current I that creates a steady magnetic field B inside the toroid. For current in the sense shown in the figure, the system has nonzero electromagnetic field momentum (see, for example, sec. 2.1.1 of [144]),

$$\mathbf{P}_{\text{EM}} = \frac{\pi b^2 I e}{c^2} \frac{a}{(z^2 + a^2)^{3/2}} \hat{\mathbf{z}}, \quad (14)$$

The system is initially “at rest,” and according to the center-of-energy theorem its total, initial momentum is zero. The momentum equal and opposite to the initial field momentum is the “hidden” mechanical momentum associated with the current in the toroid.

If at some later time the current goes to zero, then an electric field is induced, which transfers the initial field momentum into the final “mechanical” momentum of the electric

¹⁷For additional discussion, see [147]. Slepian also described an “electrostatic spaceship” at [40].

¹⁸To avoid consideration of electrostatic forces associated with charges induced on the conductor of the toroid, one can suppose its current is due to pairs of counter-rotating, oppositely charged disks.

¹⁹This paradox was revived in [49, 52, 128], without reference to Cullwick.

charge.^{20,21} Meanwhile, the now-moving charge exerts a force on the toroid as long as the current is nonzero, such that the final mechanical momentum of the toroid is equal and opposite to the final “mechanical” momentum of the electric charge.

The total momentum of the system is zero at all times. The system does not constitute a “bootstrap spaceship”.

C.7 Feynman

In 1963, Feynman posed the now-famous disk paradox related to field angular momentum in sec. 17-4 of [51]. This paradox was perhaps inspired by a comment of J.J. Thomson, p. 348 of [25], and has led to extensive additional commentary, including [57, 59, 61, 81, 84, 86, 88, 89, 90, 93, 94, 95, 96, 97, 99, 100, 105, 110].

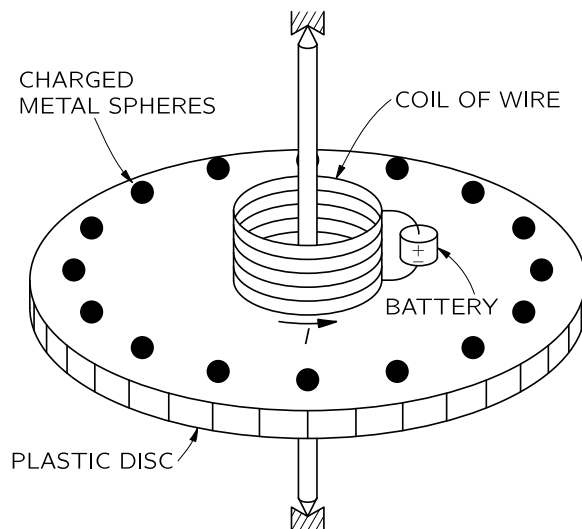

An insulating disk has electric charge around its rim and is initially at rest. This disk is coaxial with a solenoid magnet that initially has nonzero current, and the disk is free to rotate with respect to the solenoid.

If at some time the current in the solenoid goes to zero, the decreasing magnetic flux in the solenoid induces an azimuthal electric field that causes the charged disk to rotate. The “paradox” is that this behavior appears to violate conservation of angular momentum.

At the end of sec. 27-6 of [51], Feynman gave a verbal resolution of the paradox: *Do you remember the paradox we described in Section 17-4 about a solenoid and some charges mounted on a disc? It seemed that when the current turned off, the whole disc should start to turn. The puzzle was: Where did the angular momentum come from? The answer is that if you have a magnetic field and some charges, there will be some angular momentum in the field. It must have been put there when the field was built up. When the field is turned off, the angular momentum is given back. So the disc in the paradox would start rotating.*

²⁰This process is the principle of the *induction linac*, invented in 1964 [50].

²¹We consider the momentum of the self-field of the electric charge to be part of its “mechanical” momentum”. One could also take the view that the momentum in the initial static fields of the system has been transferred into the momentum of the self-fields of the moving electric charge.

This mystic circulating flow of energy,²² which at first seemed so ridiculous, is absolutely necessary. There is really a momentum flow. It is needed to maintain the conservation of angular momentum in the whole world.

The Feynman disk apparatus was called a “bootstrap merry-go-round” in [69].

The total field momentum is zero in the Feynman disk apparatus, as also is the total mechanical momentum. There is, of course, some mechanical momentum associated with the electric current, but this is not a “hidden” mechanical momentum in the sense of the definition advocated at [171, 174].

C.8 Shockley

In 1967, Shockley and James [63] considered a variant of the Feynman disk apparatus, as shown below.

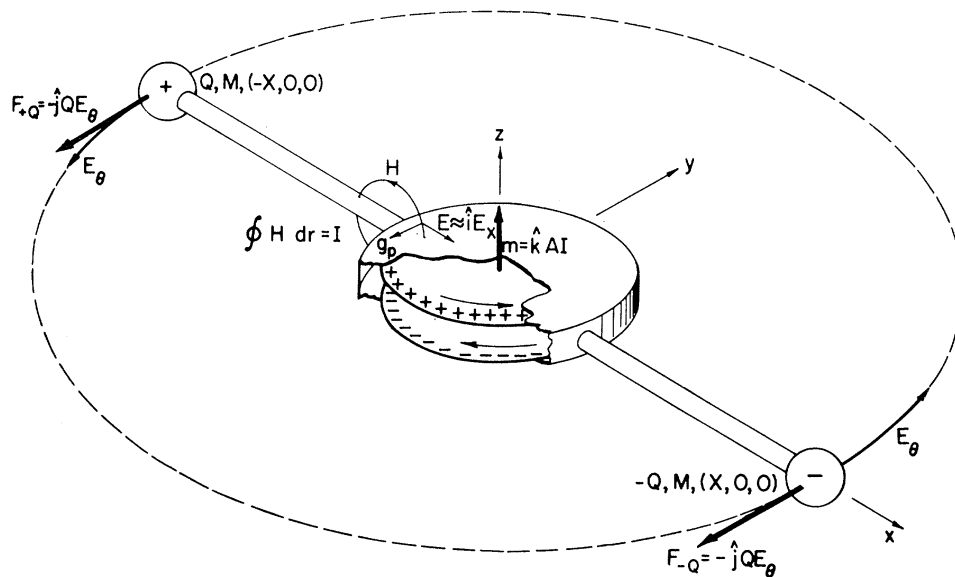

The (isolated) system is initially at rest, with the two oppositely charged disks rotating with opposite senses. Charges $\pm Q$ are attached to a nonconducting rod that is connected to the axle of the oppositely charged disks. A nonconducting “pillbox” surrounds the latter.

The rotation of the disks might later be slowed to zero, during which time forces would be exerted on the charges $\pm Q$ due to the electric field \mathbf{E}_θ induced by the decreasing magnetic field of the magnetic dipole $\mathbf{m}(t)$, as shown in the figure. This suggests that the final center of mass of the system would be displaced in the y -direction compared to its initial value.

Shockley considered this to be impossible (without formally invoking the center-of-energy theorem), and that the apparatus would not move (even if not held in place by external forces), *i.e.*, it is not a “bootstrap spaceship”. Rather, he argued²³ that the forces identified above are opposed by “pseudoforces” associated with changes in “hidden” mechanical momentum inside the apparatus.²⁴

²²Feynman referred here to the nonzero Poynting vector [17], $\mathbf{S} = (c/4\pi)\mathbf{E} \times \mathbf{B}$, that can exist in static electromagnetic configurations, such as the present example.

²³For more details of Shockley’s argument, see the companion note [211].

²⁴This was the first use of the term *hidden momentum*.

He also noted that when the disks are rotating, the system possesses nonzero electromagnetic field momentum, $\mathbf{E} \times \mathbf{m}/c$ in the $-y$ direction,²⁵ where \mathbf{E} is the electric field due to the charge $\pm Q$ at the origin, and that this field momentum is equal and opposite to the “hidden” mechanical momentum. Not only is the total momentum of the system zero at all times, its center of mass/energy remains always at rest.

No “bootstrap spaceships”.

C.9 Quantum-Vacuum Thrusters

Perhaps beginning with Forward (1984) [91], there have been various suggestions that some version of the Casimir effect [38] might extract energy from the quantum-electrodynamic vacuum to propel spaceships.

Of these, the so-called dynamic Casimir effect [162] can provide an extremely weak flux of photons, whose energy derives from that stored on the spaceship, and hence does not constitute a “bootstrap” spaceship.

The vision that a “reactionless drive” could be based on some kind of interaction with the QED vacuum (a “ground state”) is inconsistent with conservation of energy and momentum, as affirmed, for example, in [190].

For additional discussion, see https://en.wikipedia.org/wiki/Quantum_vacuum_thruster

C.10 Mach-Effect Thrusters

In 1990, Woodward [102] speculated that, in the spirit of a conjecture of Mach, distant masses somehow affect the mass of accelerated, local masses, which supposedly implies that transient electromagnetic systems could constitute “bootstrap spaceships”. This led to numerous, conflicting reports of such effects in experiments with transient electrical circuits, all readily ascribed to “experimental error”. See, for example, [179], and sec. 2.2 of [210].

Of course, a transient circuit emits electromagnetic radiation, which can lead to a (very weak) propulsive force on the circuit, but which would not be a “reactionless drive” as imagined for a “bootstrap spaceship”.²⁶

C.11 Brito (added May 18, 2021)

Beginning in 1998, Brito [115, 121, 125, 126, 133, 145, 146] noted that a magnetic field inside a capacitor contains a nonzero electromagnetic field momentum (unless \mathbf{B} is parallel to \mathbf{E}), and it must be that the momentum could be released to drive the center of mass of the system.²⁷ However, Brito’s systems are better described as containing “hidden” mechanical momentum (in the currents of the magnets), such that if the currents drop to zero, the release of the “hidden” mechanical momentum just cancels the loss of the field momentum, with no effect on the motion of the center of mass of the system.

²⁵This field momentum for a magnet plus electric charges was first computed on p. 347 of [25].

²⁶See, for example, [80].

²⁷Brito distracted the reader with mention of the so-called Abraham-Minkowski controversy (see, for example, [193]) as to the character of electromagnetic momentum inside dielectrics.

C.12 Boyer

Beginning in 2001, Boyer has written a series of papers [122, 130, 134, 135, 138, 151, 152, 152, 186, 187] on the theme of “hidden” momentum, with varying attitudes as to whether or not this entity exists in Nature.²⁸ Boyer’s hope is perhaps that a microscopic analysis based on a Darwin lagrangian will avoid the need to consider “hidden” momentum, but he seems to accept that in macroscopic analyses there is a role for this concept.

His comments are generally consistent with the view that there are no “bootstrap spaceships”.

C.13 Shawyer

Beginning in 2005, Shawyer [131, 201] has claimed that experiments with an rf cavity in the form of a truncated cone show an extremely time propulsive force.²⁹ This claim has been supported by a few others, such as [165, 203].

These authors also claim that the propulsive force is due to the pressure of the electromagnetic cavity fields on the cavity, which would be a “self force”. This is a misunderstanding of the consequences of Maxwell’s equations, as reviewed in [206].

While there is still no crisp explanation for the tiny forces seen in various experiments, the present author considers that they are likely to be thermal effects, as in the famous case of the Crookes radiometer.^{30,31}

C.14 Onoochin

Various schemes for “bootstrap” spaceships have been advocated to the present author by Onoochin [137, 202, 212, 213], all of which are based on misunderstandings of how momentum is conserved in electromagnetic interactions.

C.15 Engelhardt

In 2008, Engelhardt [155] discussed a “Lorentz rocket”, that supposedly took advantage of the fact that the Lorentz forces between two moving charges are not equal and opposite to result in a net, nonzero self force on a system of charges and currents. For more discussion, see [216].

²⁸These papers are part of a larger series that purports to show that much of quantum theory is actually “classical”.

²⁹See also, <http://www.emdrive.com/>

³⁰In 1876, Crookes demonstrated his famous radiometer (aka “light mill”), and speculated that it was driven by the pressure of light [12]. However, it was observed by Schuster [14, 55] that the rotation of the radiometer was opposite to that consistent with radiation pressure, and instead was due to thermal effects in the residual gas inside the device.

For a review of experiments that eventually demonstrated the radiation pressure of light, see [85].

³¹Another possible explanation is Lorenz forces on the electrical cables that delivered DC power to the not-quite-isolated device, as reported in sec. 2.1 of [210].

C.16 Mansuripur

The most well-publicized objection to “hidden” momentum is perhaps that of Mansuripur (2012) [164], who argued that the Lorentz force law is wrong, and when corrected, the notion of “hidden” momentum is no longer needed. His argument was, however, not related to issues of “bootstrap spaceships”.³²

C.17 Franklin

In 2013, Franklin [180] claimed that the center-of-energy theorem does not hold, and there is no need for “hidden” momentum. In the Abstract, Franklin stated about examples like that of Shockley (sec. C.8 above); *The external force required to keep matter at rest during the production of the final static configuration produces the electromagnetic momentum.*³³ That is, Franklin considered that in the absence of any external force, such examples are “bootstrap spaceships”.

He seemed to argue that the (Lorentz) force on the charges $\pm Q$ in Shockley’s example does not change any mechanical momentum in the system if an external force holds the system “at rest”, but rather changes the field momentum (which he claimed is then the only momentum in the system).

On the other hand, if no external force were present, and the initial momentum of the (isolated) system were zero, Franklin implied that the system would be propelled to some velocity, presumably by the Lorentz force, such that (he argued) the mechanical momentum would be equal and opposite to the field momentum (which was somehow created by other action than the Lorentz force in this case). Then, the total momentum would still be zero, although the system were now in motion.

In effect, Franklin claimed that the Biot-Savart-Lorentz force, $\oint I d\mathbf{l} \times \mathbf{B}/c$, may or may not act on the current \mathbf{I} , depending on the character of other forces in the problem, such that analyses of experiments on magnetism dating back the time of Ampère have been incorrect.

Franklin recognized that his scenario violates the center-of-energy theorem, which he reviewed for *static* (and isolated) systems in eqs. (43)-(45) of his sec. IV. He also noted that in *static* systems which contain both matter (electric currents) and electromagnetic fields, the electromagnetic field momentum can be nonzero. He argued that this shows the center-of-energy theorem not to hold (rather than that the system must contain some other momentum equal and opposite to the field momentum), which conclusion could follow only if he thought the momentum \mathbf{P} of his eq. (45) were the field momentum and not the total momentum).³⁴

Franklin also promoted these arguments in a more recent paper [209].

³²A long comment by the author on Mansuripur’s views is at [167], which includes references to several other such comments.

³³Similarly, the final sentence of [180] reads: *The external force needed to keep matter at rest during the creation of the charge-current distribution goes directly into EM momentum without moving any matter or hiding any momentum.*

³⁴That is, Franklin’s claims seem to this author to follow from a basic misunderstanding of force, momentum, and the center-of-energy theorem.

C.18 Tuval and Yahalom

Tuval and Yahalom have recently advocated two “electromagnetic spaceships” [178, 197]. The first of these is based on two coupled AC circuits, and could exhibit weak propulsion in reaction to electromagnetic momentum radiated by the circuits.³⁵ The second is based on a single circuit plus a permanent magnet, and it turns out that such a system cannot radiate net momentum [200].

That is, neither of the examples of Tuval and Yahalom are “bootstrap spaceships”.

C.19 Redfern

Two recent papers by Redfern [204, 205] argued that “hidden” momentum does not exist, and, in effect, that it is perfectly acceptable for the example of Shockley (sec. C.8 above) to be a “bootstrap spaceship” (which if not held in place, would move in the $-y$ direction as the system is assembled).

While Redfern makes extensive reference to the paper of Coleman and Van Vleck [66], he does not seem to be aware that his views are inconsistent with the center-of-energy theorem, which is the keystone of that paper.

Additional comments by the author on Redfern’s paper [204] are at [211].

C.20 McClymer

A recent e-print [214] follows [207] in supposing that all photons have zero rest mass, including those inside a dielectric medium, to infer that a laser plus glass block, mounted on a platform, constitutes a “bootstrap spaceship”, and that “kinetic” photons are associated with so-called Minkowski field momentum [28].

Already in 1953 [42], an argument was given that such optical configurations are not “bootstrap spaceships”, and that “kinetic” photons are associated with so-called Abraham field momentum [29], rather than Minkowski momentum.³⁶ See also [215].

Acknowledgment

The author thanks Vladimir Hnizdo and Pablo Saldanha for e-discussions of this topic.

References

- [1] F. Hauksbee, *Physico-Mechanical Experiments on Various Subjects, Containing an Account of Surprising Phenomena Touching Light and Electricity* (London, 1709), pp. 46-47, kirkmcd.princeton.edu/examples/EM/hauksbee_expts_09.pdf
Hauksbee was Newton’s lab assistant.

³⁵For a review of schemes for rocket propulsion based on laser beams, see [148].

³⁶For a review of the physical significance of the Abraham and Minkowski momenta, see [159].

- [2] I. Newton, *Opticks*, 2nd ed. (London, 1718), p. 315,
kirkmcd.princeton.edu/examples/optics/newton_opticks_18.pdf
- [3] J.C. Ørsted, *Experimenta circa Effectum Conflictus Electrici in Acum Magneticam* (pamphlet, Berlin, 1829), kirkmcd.princeton.edu/examples/EM/oersted_experimenta.pdf
- [4] J.C. Oersted, *Experiments on the Effect of a Current of Electricity on the Magnetic Needle*, Ann. Phil. **16**, 273 (1820), kirkmcd.princeton.edu/examples/EM/oersted_ap_16_273_20.pdf
- [5] A.M. Ampère, *Mémoire sur la détermination de la formule qui représente l'action mutuelle de deux portions infiniment petites de conducteurs voltaïques*, Ann. Chem. Phys. **20**, 398, 422 (1822), kirkmcd.princeton.edu/examples/EM/ampere_acp_20_398_22.pdf
 Discussion in English of Ampère's attitudes on the relation between magnetism and mechanics is given in, for example, [54, 119, 139, 120].
- [6] M. de La Rive fils, *Sur l'Action qu'exerce le globe terrestre sur une portion mobile du circuit voltaïque*, Ann. Chemie Phys. **21**, 24 (1822),
kirkmcd.princeton.edu/examples/EM/ampere_delarive_acp_21_24_22.pdf
- [7] M. Faraday, *Experimental Researches in Electricity*, Phil. Trans. Roy. Soc. London **122**, 125 (1832), kirkmcd.princeton.edu/examples/EM/faraday_ptrsl_122_163_32.pdf
- [8] M. Faraday, *Experimental Researches in Electricity.—Ninth Series*, Phil. Trans. Roy. Soc. London **125**, 41 (1832), kirkmcd.princeton.edu/examples/EM/faraday_ptrsl_125_41_35.pdf
- [9] M. Faraday, *Experimental Researches in Electricity.—Twelfth Series*, Phil. Trans. Roy. Soc. London **128**, 89 (1832), kirkmcd.princeton.edu/examples/EM/faraday_ptrsl_128_89_38.pdf
- [10] H. Grassmann, *Neue Theorie der Elektrodynamik*, Ann. d. Phys. **64**, 1 (1845),
kirkmcd.princeton.edu/examples/EM/grassmann_ap_64_1_45.pdf
kirkmcd.princeton.edu/examples/EM/grassmann_ap_64_1_45_english.pdf
- [11] J.C. Maxwell, *A Dynamical Theory of the Electromagnetic Field*, Phil. Trans. Roy. Soc. London **155**, 459 (1865), kirkmcd.princeton.edu/examples/EM/maxwell_ptrsl_155_459_65.pdf
- [12] W. Crookes, *On Repulsion resulting from Radiation.—Parts III & IV*, Phil. Trans. Roy. Soc. London **166**, 325 (1876), kirkmcd.princeton.edu/examples/optics/crookes_ptrsl_166_325_76.pdf
- [13] J.C. Maxwell, *A Treatise on Electricity and Magnetism* (Clarendon Press, Oxford, 1873),
kirkmcd.princeton.edu/examples/EM/maxwell_treatise_v2_73.pdf
- [14] A. Schuster, *On the Nature of the Force producing the Motion of a Body exposed to Rays of Heat and Light*, Phil. Trans. Roy. Soc. London **166**, 715 (1876),
kirkmcd.princeton.edu/examples/statmech/schuster_ptrsl_166_715_76.pdf
- [15] J.J. Thomson, *On the Electric and Magnetic Effects produced by the Motion of Electrified Bodies*, Phil. Mag. **11**, 229 (1881),
kirkmcd.princeton.edu/examples/EM/thomson_pm_11_229_81.pdf

- [16] O. Heaviside, *Electromagnetic Theory*, Vol. 1 (Electrician Publishing, 1883), p. 108,
kirkmcd.princeton.edu/examples/EM/heaviside_electromagnetic_theory_1.pdf
- [17] J.H. Poynting, *On the Transfer of Energy in the Electromagnetic Field*, Phil. Trans. Roy. Soc. London **175**, 343 (1884),
kirkmcd.princeton.edu/examples/EM/poynting_ptrs1_175_343_84.pdf
- [18] J.J. Thomson, *On the Illustration of the Properties of the Electric Field by Means of Tubes of Electrostatic Induction*, Phil. Mag. **31**, 149 (1891),
kirkmcd.princeton.edu/examples/EM/thomson_pm_31_149_91.pdf
- [19] J.J. Thomson, *Recent Researches in Electricity and Magnetism* (Clarendon Press, 1893),
http://kirkmcd.princeton.edu/examples/EM/thomson_recent_researches_in_electricity.pdf
- [20] H. Poincaré, *La Théorie de Lorentz et la Principe de Réaction*, Arch. Neer. **5**, 252 (1900), kirkmcd.princeton.edu/examples/EM/poincare_an_5_252_00.pdf
 Translation: *The Theory of Lorentz and the Principle of Reaction*,
kirkmcd.princeton.edu/examples/EM/poincare_an_5_252_00_english.pdf
- [21] P. Lebedew, *Untersuchen über die Druckkräfte des Lichtes*, Ann. Phys. **6**, 433 (1901),
kirkmcd.princeton.edu/examples/EM/lebedev_ap_6_433_01.pdf
- [22] K. Birkeland, *Electromagnetic Gun*, US Patent 754,637 (filed Jan. 2, 1902),
kirkmcd.princeton.edu/examples/patents/birkeland_us754637_02_gun.pdf
- [23] M. Abraham, *Prinzipien der Dynamik des Elektrons*, Ann. Phys. **10**, 105 (1903),
physics.princeton.edu/~mcdonald/examples/EM/abraham_ap_10_105_03.pdf
- [24] E.F. Nichols and G.F. Hull, *The Pressure Due to Radiation*, Phys. Rev. **17**, 26,91 (1903),
kirkmcd.princeton.edu/examples/EM/nichols_pr_17_26_03.pdf
- [25] J.J. Thomson, *On Momentum in the Electric Field*, Phil. Mag. **8**, 331 (1904),
kirkmcd.princeton.edu/examples/EM/thomson_pm_8_331_04.pdf
- [26] J.J. Thomson, *Elements of the Mathematical Theory of Electricity and Magnetism*, 3rd ed. (Cambridge U. Press, 1904), http://kirkmcd.princeton.edu/examples/EM/thomson_EM_3rd_ed_04.pdf
- [27] J.J. Thomson, *Electricity and Matter* (Charles Scribner's Sons, 1904), pp. 25-35,
kirkmcd.princeton.edu/examples/EM/thomson_electricity_matter_04.pdf
- [28] H. Minkowski, *Die Grundgleichungen für die elektromagnetischen Vorgänge in bewegten Körper*, Nachr. Ges. Wiss. Göttingen **1**, 53 (1908),
kirkmcd.princeton.edu/examples/EM/minkowski_ngwg_53_08.pdf
kirkmcd.princeton.edu/examples/EM/minkowski_ngwg_53_08_english.pdf
- [29] M. Abraham, *Zur Elelktrodynamik bewegten Körper*, Rend. Circ. Matem. Palermo **28**, 1 (1909), kirkmcd.princeton.edu/examples/EM/abraham_rcmp_28_1_09.pdf
kirkmcd.princeton.edu/examples/EM/abraham_rcmp_28_1_09_english.pdf

- [30] M. Abraham, *Sull'Elettrodinamica di Minkowski*, Rend. Circ. Matem. Palermo **30**, 33 (1910), kirkmcd.princeton.edu/examples/EM/abraham_rcmp_30_33_10.pdf
kirkmcd.princeton.edu/examples/EM/abraham_rcmp_30_33_10_english.pdf
- [31] C. Hering, *The Stretching of a Conductor by Its Current*, J. Franklin Inst. **171**, 73 (1911), kirkmcd.princeton.edu/examples/EM/hering_jfi_171_73_11.pdf
- [32] O. Heaviside, *Electromagnetic Theory*, Vol. 3 (Electrician Publishing, 1912), pp. 146-147, kirkmcd.princeton.edu/examples/EM/heaviside_electromagnetic_theory_3.pdf
- [33] M. Abraham, *Zur Frage der Symmetrie des elektromagnetischen Spannungstensors*, Z. Phys. **17**, 537 (1914), kirkmcd.princeton.edu/examples/EM/abraham_zp_15_537_14_english.pdf
- [34] C.G. Darwin, *The Dynamical Motions of Charged Particles*, Phil. Mag. **39**, 537 (1920), kirkmcd.princeton.edu/examples/EM/darwin_pm_39_537_20.pdf
- [35] T.T. Brown, *Gravitator: A Method of and an Apparatus or Machine for Producing Force or Motion*, British patent 300,311 (1928),
<http://www.rexresearch.com/gravitor/gravitor.htm>
kirkmcd.princeton.edu/examples/EM/brown_gravitator.pdf
- [36] L. Page, *Momentum Considerations in Crossed Fields*, Phys. Rev. **42**, 101 (1932), kirkmcd.princeton.edu/examples/EM/page_pr_42_101_32.pdf
- [37] L. Page and N.I. Adams, Jr, *Action and Reaction Between Moving Charges*, Am. J. Phys. **13**, 141 (1945), kirkmcd.princeton.edu/examples/EM/page_ajp_13_141_45.pdf
- [38] H.B.G. Casimir, *On the attraction between two perfectly conducting plates*, Proc. K. Ned. Akad. Wet. Amsterdam **51**, 793 (1948),
http://kirkmcd.princeton.edu/examples/QED/casimir_pknaw_b51_793_48.pdf
- [39] J. Slepian, *Electromagnetic Space-Ship*, Electrical Engineering **68**, 145, 245 (1949), kirkmcd.princeton.edu/examples/EM/slepian_ee_68_145_49
- [40] J. Slepian, *Electrostatic Space Ship*, Electrical Engineering **69**, 164, 247 (1950), kirkmcd.princeton.edu/examples/EM/slepian_ee_69_164_50.pdf
- [41] E.G. Cullwick, *Electromagnetic Momentum and Newton's Third Law*, Nature **170**, 425 (1952), kirkmcd.princeton.edu/examples/EM/cullwick_nature_170_425_52.pdf
- [42] N.L. Balazs, *The Energy-Momentum Tensor of the Electromagnetic Field inside Matter*, Phys. Rev. **91**, 408 (1953), kirkmcd.princeton.edu/examples/EM/balazs_pr_91_408_53.pdf
- [43] N.L. Dean, *System for Converting Rotary Motion into Unidirectional Motion*, US Patent 2,886,976 (filed July 13, 1956),
kirkmcd.princeton.edu/examples/patents/dean_us2886976_56_propulsion.pdf
- [44] E.G. Cullwick, *Electromagnetism and Relativity* (Longmans, Green, 1959), pp. 232-238, kirkmcd.princeton.edu/examples/EM/cullwick_ER_59.pdf

- [45] Y. Aharonov and D. Bohm, *Significance of Electromagnetic Potentials in Quantum Theory*, Phys. Rev. **115**, 485 (1959),
http://kirkmcd.princeton.edu/examples/QM/aharonov_pr_115_485_59.pdf
- [46] R.M. Fano, L.J. Chu and R.B. Adler, *Electromagnetic Fields, Energy and Forces* (Wiley, 1960), kirkmcd.princeton.edu/examples/EM/fano_chu_adler_60.pdf
- [47] M. Robinson, *A History of the Electric Wind*, Am. J. Phys. **30**, 366 (1962),
kirkmcd.princeton.edu/examples/EM/robinson_ajp_30_366_62.pdf
- [48] R.D.H. Tellegen, *Magnetic-Dipole Models*, Am. J. Phys. **30**, 650 (1962),
kirkmcd.princeton.edu/examples/EM/tellegen_ajp_30_650_62.pdf
- [49] G.T. Trammel, *Aharonov-Bohm Paradox*, Phys. Rev. **134**, B1183 (1964),
kirkmcd.princeton.edu/examples/EM/trammel_pr_134_B1183_64.pdf
- [50] N.C. Cristofilos *et al.*, *High Current Linear Induction Accelerator for Electrons*, Rev. Sci. Instr. **35**, 585 (1964), kirkmcd.princeton.edu/examples/accel/christofilos_rsi_35_88_64.pdf
- [51] R.P. Feynman, R.B. Leighton and M. Sands, *The Feynman Lectures on Physics*, Vol. II (Addison Wesley, 1964),
http://www.feynmanlectures.caltech.edu/II_17.html#Ch17-S4
http://www.feynmanlectures.caltech.edu/II_27.html#Ch27-S5
http://www.feynmanlectures.caltech.edu/II_27.html#Ch27-S6
- [52] T.T. Taylor, *Electrodynamic Paradox and the Center-of-Mass Principle*, Phys. Rev. **137**, B467 (1965), kirkmcd.princeton.edu/examples/EM/taylor_pr_137_B467_65.pdf
- [53] R.P. McKenna, *Case of the Paradoxical Invention*, Analog **75**, No. 1, 14 (1965),
kirkmcd.princeton.edu/examples/EM/mckenna_analog_75_1_14_65.pdf
- [54] R.A.R. Tricker, *Early Electrodynamics, the First Law of Circulation* (Pergamon, 1965),
kirkmcd.princeton.edu/examples/EM/tricker_early_em.pdf
- [55] A.E. Woodruff, *William Crookes and the Radiometer*, Isis **57**, 188 (1966),
kirkmcd.princeton.edu/examples/optics/woodruff_isis_57_188_66.pdf
- [56] P. Penfield, Jr and H.A. Haus, *Electrodynamics of Moving Media* (MIT, 1967), p. 215,
kirkmcd.princeton.edu/examples/EM/penfield_haus_chap7.pdf
- [57] R.H. Romer, *Angular Momentum of Static Electromagnetic Fields*, Am. J. Phys. **34**, 772 (1966), kirkmcd.princeton.edu/examples/EM/romer_ajp_34_772_66.pdf
- [58] M.G. Calkin, *Linear Momentum of Quasistatic Electromagnetic Fields*, Am. J. Phys. **34**, 921 (1966), kirkmcd.princeton.edu/examples/EM/calkin_ajp_34_921_66.pdf
- [59] E.M. Pugh and G.E. Pugh, *Physical Significance of the Poynting Vector in Static Fields*, Am. J. Phys. **35**, 153 (1967), kirkmcd.princeton.edu/examples/EM/pugh_ajp_35_153_67.pdf

- [60] E.A. Christenson and P.S. Moller, *Ion-Neutral Propulsion in Atmospheric Media*, AIAA J. **5**, 1768 (1967), kirkmcd.princeton.edu/examples/EM/christenson_aiaaj_5_1768_67.pdf
- [61] R.H. Romer, *Electromagnetic Angular Momentum*, Am. J. Phys. **35**, 445 (1967), kirkmcd.princeton.edu/examples/EM/romer_ajp_35_445_67.pdf
- [62] O. Costa de Beauregard, *A New Law in Electrodynamics*, Phys. Lett. A **24**, 177 (1967), kirkmcd.princeton.edu/examples/EM/costa_de_beauregard_pl_24a_177_67.pdf
- [63] W. Shockley and R.P. James, “*Try Simplest Cases*” *Discovery of “Hidden Momentum” Forces on “Magnetic Currents,”* Phys. Rev. Lett. **18**, 876 (1967), kirkmcd.princeton.edu/examples/EM/shockley_prl_18_876_67.pdf
- [64] O. Costa de Beauregard, *Physical Reality of Electromagnetic Potentials?* Phys. Lett. A **25**, 95 (1967), kirkmcd.princeton.edu/examples/EM/costa_de_beauregard_pl_25a_95_67.pdf
- [65] H.A. Haus and P. Penfield Jr, *Forces on a Current Loop*, Phys. Lett. A **26**, 412 (1968), kirkmcd.princeton.edu/examples/EM/penfield_pl_26a_412_68.pdf
- [66] S. Coleman and J.H. Van Vleck, *Origin of “Hidden Momentum” Forces on Magnets*, Phys. Rev. **171**, 1370 (1968), kirkmcd.princeton.edu/examples/EM/coleman_pr_171_1370_68.pdf
- [67] W.H. Furry, *Examples of Momentum Distributions in the Electromagnetic Field and in Matter*, Am. J. Phys. **37**, 621 (1969), kirkmcd.princeton.edu/examples/EM/furry_ajp_37_621_69.pdf
- [68] O. Costa de Beauregard, “*Hidden Momentum*” *in Magnets and Interaction Energy*, Phys. Lett. A **28**, 365 (1968), kirkmcd.princeton.edu/examples/EM/costa_de_beauregard_pl_28a_365_68.pdf
- [69] O. Costa de Beauregard, *Magnetodynamic Effect*, Nuovo Cim. B **63**, 611 (1969), kirkmcd.princeton.edu/examples/EM/costa_de_beauregard_nc_b63_611_69.pdf
- [70] M.G. Calkin, *Linear Momentum of the Source of a Static Electromagnetic Field*, Am. J. Phys. **39**, 513 (1971), kirkmcd.princeton.edu/examples/EM/calkin_ajp_39_513_71.pdf
- [71] E.R. Laithwaite and W.R.C. Dawson, *A System for the Transfer of Mass Derived from the Principle of Conservation of Momentum* (Sept. 1974), kirkmcd.princeton.edu/examples/mechanics/laithwaite_sep74.pdf
- [72] E.R. Laithwaite, *The multiplication of bananas by umbrellas*, Elec. Rev. **195**, 822 (1974), kirkmcd.princeton.edu/examples/mechanics/laithwaite_er_195_822_74.pdf
- [73] E.R. Laithwaite, *The Engineer Through the Looking Glass*, Roy. Inst. Christmas Lectures (1974), <http://www.rigb.org/blog/2013/december/eric-laithwaite>
<https://www.rigb.org/christmas-lectures/watch/1974/the-engineer-through-the-looking-glass/the-jabberwock>
- [74] E.R. Laithwaite, *The bigger they are, the harder they fall*, Elec. Rev. **196**, 188 (1975), kirkmcd.princeton.edu/examples/mechanics/laithwaite_er_196_188_75.pdf

- [75] E.R. Laithwaite, *1975—a space odyssey*, Elec. Rev. **196**, 398 (1975),
kirkmcd.princeton.edu/examples/mechanics/laithwaite_er_196_398_75.pdf
- [76] L.D. Landau and E.M. Lifshitz, *The Classical Theory of Fields*, 4th ed. (Butterworth-Heinemann, Oxford, 1975), kirkmcd.princeton.edu/examples/EM/landau_ctf_75.pdf
 The first Russian edition appeared in 1941.
kirkmcd.princeton.edu/examples/EM/landau_teorija_polya_41.pdf
- [77] E.J. Konopinski, *What the electromagnetic vector potential describes*, Am. J. Phys. **46**, 499 (1978), kirkmcd.princeton.edu/examples/EM/konopinski_ajp_46_499_78.pdf
- [78] S.C. Rashleigh and R.A. Marshall, *Electromagnetic acceleration of macroparticles to high velocities*, J. Appl. Phys. **49**, 2540 (1978),
kirkmcd.princeton.edu/examples/EM/rashleigh_jap_49_2540_78.pdf
- [79] E.R. Laithwaite, *Roll Isaac, roll*, Elec. Rev. **204** (7), 38: (11), 31 (1979),
kirkmcd.princeton.edu/examples/mechanics/laithwaite_er_204-7_38_79.pdf
- [80] K.T. McDonald, *The Force on an Antenna Array* (May 1, 1979),
kirkmcd.princeton.edu/examples/antenna_force.pdf
- [81] E. Corinaldesi, *Angular momentum of a static electromagnetic field*, Am. J. Phys. **48**, 83 (1980), kirkmcd.princeton.edu/examples/EM/corinaldesi_ajp_48_83_80.pdf
- [82] E.R. Laithwaite, *Give us a sign*, Elec. Rev. **207** (3), 80 (1980),
kirkmcd.princeton.edu/examples/mechanics/laithwaite_er_207-3_40_80.pdf
- [83] G.E. Stedman, *Observability of Static Electromagnetic Angular Momentum*, Phys. Lett. A **81**, 15 (1981), kirkmcd.princeton.edu/examples/EM/stedman_pl_81a_15_81.pdf
- [84] J.M. Aguirregabiria and A. Hernández, *The Feynman paradox revisited*, Eur. J. Phys. **2**, 168 (1981), kirkmcd.princeton.edu/examples/EM/aguirregabiria_ejp_2_168_81.pdf
- [85] J. Worrall, *The pressure of light: The strange case of the vacillating ‘crucial experiment’*, Stud. Hist. Phil. Sci. A **13**, 133 (1982),
kirkmcd.princeton.edu/examples/optics/worrall_shpsa_13_133_82.pdf
- [86] G.G. Lombardi, *Feynman’s disk paradox*, Am. J. Phys. **51**, 213 (1983),
physics.princeton.edu/~mcdonald/examples/EM/lombardi_ajp_51_213_83.pdf
- [87] P. Graneau, *First Indication of Ampere Tension in Solid Electric Conductors*, Phys. Lett. A **97**, 253 (1983), kirkmcd.princeton.edu/examples/EM/graneau_pl_97a_253_83.pdf
- [88] F.L. Boos, Jr, *More on the Feynman’s Disk Paradox*, Am. J. Phys. **52**, 756 (1984),
kirkmcd.princeton.edu/examples/EM/boos_ajp_52_756_84.pdf
- [89] J. Belcher and K.T. McDonald, *Feynman Cylinder Paradox* (Fall, 1983),
kirkmcd.princeton.edu/examples/feynman_cylinder.pdf

- [90] T. Bahder and J. Sak, *Elementary solution to Feynman's disk paradox*, Am. J. Phys. **53**, 495 (1985), kirkmcd.princeton.edu/examples/EM/bahder_ajp_53_495_85.pdf
- [91] R.L. Forward, *Extracting electrical energy from the vacuum by cohesion of charged foliated conductors*, Phys. Rev. B **30**, 1700 (1984), kirkmcd.princeton.edu/examples/QED/forward_prb_30_1700_84.pdf
- [92] K.T. McDonald, *Stress and Momentum in a Capacitor That Moves with Constant Velocity* (Apr. 21, 1984), kirkmcd.princeton.edu/examples/cap_stress.pdf
- [93] O.B. Keyes, *Comments on "Feynman's Disk Paradox"*, Am. J. Phys. **52**, 680 (1984), kirkmcd.princeton.edu/examples/EM/keyes_ajp_52_680_84.pdf
- [94] R.H. Romer, *Electromagnetic Angular Momentum*, Am. J. Phys. **53**, 15 (1985), kirkmcd.princeton.edu/examples/EM/romer_ajp_53_15_85.pdf
- [95] T.-C.E. Ma, *Field angular momentum in Feynman's disk paradox*, Am. J. Phys. **54**, 949 (1986), kirkmcd.princeton.edu/examples/EM/ma_ajp_54_949_86.pdf
- [96] H.S.T. Driver, *Angular momentum in static electric and magnetic fields: A simple case*, Am. J. Phys. **55**, 755 (1987), kirkmcd.princeton.edu/examples/EM/driver_ajp_55_755_87.pdf
- [97] N.L. Sharma, *Field versus action at a distance in a static situation*, Am. J. Phys. **56**, 420 (1988), kirkmcd.princeton.edu/examples/EM/sharma_ajp_56_420_88.pdf
- [98] Y. Aharonov, P. Pearle and L. Vaidman, *Comment on "Proposed Aharonov-Casher effect: Another example of an Aharonov-Bohm effect arising from a classical lag,"* Phys. Rev. A **37**, 4052 (1988), kirkmcd.princeton.edu/examples/QM/aharonov_pra_37_4052_88.pdf
- [99] D.J. Griffiths, *Note on "Field versus action-at-a-distance in a static situation" by N.L. Sharma*, Am. J. Phys. **57**, 558 (1989), kirkmcd.princeton.edu/examples/EM/griffiths_ajp_57_558_89.pdf
- [100] A.S. de Castro, *Electromagnetic angular momentum for a rotating charged shell*, Am. J. Phys. **59**, 180 (1991), kirkmcd.princeton.edu/examples/EM/decastro_ajp_59_180_91.pdf
- [101] L. Vaidman, *Torque and force on a magnetic dipole*, Am. J. Phys. **58**, 978 (1990), kirkmcd.princeton.edu/examples/EM/vaidman_ajp_58_978_90.pdf
- [102] J.F. Woodward, *A New Experimental Approach to Mach's Principle and Relativistic Gravitation*, Found. Phys. Lett. **3**, 497 (199=02), http://kirkmcd.princeton.edu/examples/EM/woodward_fpl_3_497_90.pdf
- [103] V. Hnizdo, *Conservation of linear and angular momentum and the interaction of a moving charge with a magnetic dipole*, Am. J. Phys. **60**, 242 (1992), kirkmcd.princeton.edu/examples/EM/hnizdo_ajp_60_242_92.pdf
- [104] D.J. Griffiths, *Dipoles at rest*, Am. J. Phys. **60**, 979 (1992), kirkmcd.princeton.edu/examples/EM/griffiths_ajp_60_979_92.pdf

- [105] F.S. Johnson, B.L. Cragin and R.L. Hodges, *Electromagnetic momentum density and the Poynting vector in static fields*, Am. J. Phys. **62**, 33 (1994), kirkmcd.princeton.edu/examples/EM/johnson_ajp_62_33_94.pdf
- [106] R.H. Romer, *Question #26: Electromagnetic field momentum*, Am. J. Phys. **63**, 777 (1995), kirkmcd.princeton.edu/examples/EM/romer_ajp_63_777_95.pdf
- [107] E.R. Laithwaite and W. Dawson, *Propulsion System*, US Patent 5,860,317 (filed May 5, 1995), kirkmcd.princeton.edu/examples/patents/laithwaite_us5860317_95_propulsion.pdf
- [108] E. Comay, *Exposing “hidden momentum”*, Am. J. Phys. **64**, 1028 (1996), kirkmcd.princeton.edu/examples/EM/comay_ajp_64_1028_96.pdf
- [109] V. Hnizdo, *Hidden momentum and the electromagnetic mass of a charge and current carrying body*, Am. J. Phys. **65**, 55 (1997), kirkmcd.princeton.edu/examples/EM/hnizdo_ajp_65_55_97.pdf
- [110] O. Rojo, *On the Energy Flow Vector of the E-M Field*, Rev. Bras. Ens. Fis. **19**, 396 (1997), kirkmcd.princeton.edu/examples/EM/rojo_rbef_19_396_97.pdf
- [111] M.G. Calkin, *Lagrangian and Hamiltonian Mechanics* (World Scientific, 1996), kirkmcd.princeton.edu/examples/mechanics/calkin_96.pdf
- [112] V. Hnizdo, *Hidden momentum of a relativistic fluid in an external field*, Am. J. Phys. **65**, 92 (1997), kirkmcd.princeton.edu/examples/EM/hnizdo_ajp_65_92_97.pdf
- [113] V. Hnizdo, *Hidden mechanical momentum and the field momentum in stationary electromagnetic and gravitational systems*, Am. J. Phys. **65**, 515 (1997), kirkmcd.princeton.edu/examples/EM/hnizdo_ajp_65_515_97.pdf
- [114] V. Hnizdo, *Covariance of the total energy-momentum four-vector of a charge and current carrying macroscopic body*, Am. J. Phys. **66**, 414 (1998), kirkmcd.princeton.edu/examples/EM/hnizdo_ajp_66_414_98.pdf
- [115] H.H. Brito, *Propellantless Propulsion by Electromagnetic Inertia Manipulation: Theory and Experiment*, AIP Conf. Proc. **458**, 94 (1999), http://kirkmcd.princeton.edu/examples/EM/brito_aipcp_458_994_99.pdf
- [116] D.J. Griffiths, *Introduction to Electrodynamics*, 3rd ed. (Prentice Hall, 1999), http://kirkmcd.princeton.edu/examples/EM/griffiths_em3.pdf
- [117] J.D. Jackson, *Classical Electrodynamics*, 3rd ed. (Wiley, 1999), http://kirkmcd.princeton.edu/examples/EM/jackson_ce3_99.pdf
- [118] E. Comay, *Lorentz transformation of a system carrying Hidden Momentum*, Am. J. Phys. **68**, 1007 (2000), kirkmcd.princeton.edu/examples/EM/comay_ajp_68_1007_00.pdf
- [119] O. Darrigol, *Electrodynamics from Ampère to Einstein* (Oxford U. Press, 2000), http://kirkmcd.princeton.edu/examples/EM/darrigol_em_00.pdf

- [120] J.D. Jackson and L.B. Okun, *Historical roots of gauge invariance*, Rev. Mod. Phys. **73**, 663 (2001), kirkmcd.princeton.edu/examples/EM/jackson_rmp_73_663_01.pdf
- [121] H. Brito, *Research on Achieving Thrust by EM Inertia Manipulation*, AIAA 2001-3556, http://kirkmcd.princeton.edu/examples/EM/brito_aiaa_2001-3656.pdf
- [122] T.H. Boyer, *Classical Electromagnetic Interaction of a Point Charge and a Magnetic Moment: Considerations Related to the Aharonov-Bohm Phase Shift*, Found. Phys. **32**, 1 (2002), kirkmcd.princeton.edu/examples/EM/boyer_fp_32_1_02.pdf
- [123] K.T. McDonald, “*Hidden*” Momentum in a Coaxial Cable (Mar. 28, 2002), kirkmcd.princeton.edu/examples/hidden.pdf
- [124] N. Thomas, *NASA Breakthrough Propulsion Physics Project: Common Errors* (Aug. 9, 2002), <http://www.asps.it/errors.htm>
kirkmcd.princeton.edu/examples/EM/thomas_nasa_02.pdf
- [125] H.H. Brito, *Experimental Status of Thrusting by Electromagnetic Inertia Manipulation*, Acad Aero. **54**, 547 (2004), http://kirkmcd.princeton.edu/examples/EM/brito_aa_54_547_04.pdf
- [126] H.H. Brito and S.A. Elaskar, *Direct Experimental Evidence of Electromagnetic Inertia Manipulation Thusting*, AIAA 2003-4989, http://kirkmcd.princeton.edu/examples/EM/brito_aiaa_2003-4989.pdf
- [127] M. Tajmar, *Biefeld-Brown Effect: Misinterpretation of Corona Wind Phenomena*, AIAA J. **42**, 315 (2004), kirkmcd.princeton.edu/examples/EM/tajmar_aiaaj_42_315_04.pdf
- [128] J.M. Aguirregabiria, A Hernández and M Rivas, *Linear momentum density in quasistatic electromagnetic systems*, Eur. J. Phys. **25**, 255 (2004), kirkmcd.princeton.edu/examples/EM/aguirregabiria_ejp_25_555_04.pdf
- [129] V. Hnizdo, *On linear momentum in quasistatic electromagnetic systems* (July 6, 2004), <http://arxiv.org/abs/physics/0407027>
- [130] T.H. Boyer, *Illustrations of the relativistic conservation law for the center of energy*, Am. J. Phys. **73**, 953 (2005), kirkmcd.princeton.edu/examples/EM/boyer_ajp_73_953_05.pdf
- [131] R. Shawyer, *The Development of a Microwave Engine for Spacecraft Propulsion* (2005), kirkmcd.princeton.edu/examples/EM/shawyer_brighton_05.pdf
- [132] G.V. Stephenson, *The Biefeld Brown Effect and the Global Electric Circuit*, AIP Conf. Proc. **746**, 1249 (2005), kirkmcd.princeton.edu/examples/EM/stephenson_aipcp_746_1249_05.pdf
- [133] H.H. Brito and S.A. Elaskar, *Overview of Theories and Experiments on Electromagnetic Inertia Manipulation Propulsion*, AIP Conf. Proc. **746**, 1395 (2005), http://kirkmcd.princeton.edu/examples/EM/brito_aipcp_746_1395_05.pdf
- [134] T.H. Boyer, *Relativity, energy flow, and hidden momentum*, Am. J. Phys. **73**, 1184 (2005), kirkmcd.princeton.edu/examples/EM/boyer_ajp_73_1184_05.pdf

- [135] T.H. Boyer, *Darwin-Lagrangian analysis for the interaction of a point charge and a magnet: considerations related to the controversy regarding the Aharonov-Bohm and Aharonov-Casher phase shifts—Relativity, energy flow, and hidden momentum*, J. Phys. A **39**, 3455 (2006), kirkmcd.princeton.edu/examples/EM/boyer_jpa_39_3455_06.pdf
- [136] M.G. Millis, *Assessing Potential Propulsion Breakthroughs*, NASA/TM-2005-213998, kirkmcd.princeton.edu/examples/EM/millis_nasa-tm-2005-0213998.pdf
- [137] K.T. McDonald, *Onoochin's Paradox* (Jan. 1, 2006), kirkmcd.princeton.edu/examples/onoochin.pdf
- [138] T.H. Boyer, *Connecting linear momentum and energy for electromagnetic systems*, Am. J. Phys. **74**, 742 (2006), kirkmcd.princeton.edu/examples/EM/boyer_ajp_74_742_06.pdf
- [139] J.R. Hofmann, *André-Marie Ampère, Enlightenment and Electrodynamics* (Cambridge U. Press, 2006).
- [140] K.T. McDonald, *Four Expressions for Electromagnetic Field Momentum* (April 10, 2006), kirkmcd.princeton.edu/examples/pem_forms.pdf
- [141] K.T. McDonald, *McKenna's Paradox: Charged Particle Exiting the Side of a Solenoid Magnet* (April 12, 2006), kirkmcd.princeton.edu/examples/mckenna.pdf
- [142] J.D. Jackson, *Relation between Interaction terms in Electromagnetic Momentum $\int d^3\mathbf{x} \mathbf{E} \times \mathbf{B}/4\pi c$ and Maxwell's $e\mathbf{A}(\mathbf{x},t)/c$, and Interaction terms of the Field Lagrangian $\mathcal{L}_{\text{em}} = \int d^3\mathbf{x} [E^2 - B^2]/8\pi$ and the Particle Interaction Lagrangian, $\mathcal{L}_{\text{int}} = e\phi - e\mathbf{v} \cdot \mathbf{A}/c$* (May 8, 2006), kirkmcd.princeton.edu/examples/EM/jackson_050806.pdf
- [143] K.T. McDonald, *Momentum in a DC Circuit* (May 26, 2006), kirkmcd.princeton.edu/examples/loop.pdf
- [144] K.T. McDonald, *Cullwick's Paradox: Charged Particle on the Axis of a Toroidal Magnet* (June 4, 2006), kirkmcd.princeton.edu/examples/cullwick.pdf
- [145] H.H. Brito and S.A. Elaskar, *Advances in Electromagnetic Inertia Propulsion*, IAC-06-C4.3.10, http://kirkmcd.princeton.edu/examples/EM/brito_iac-06-c4.3.10.pdf
- [146] H.H. Brito and S.A. Elaskar, *Direct Experimental Evidence of Electromagnetic Inertia Manipulation Thrusting*, J. Prop. Power **23**, 487 (2007), http://kirkmcd.princeton.edu/examples/EM/brito_jpp_23_487_07.pdf
- [147] K.T. McDonald, *Slepian's Electromagnetic Spaceship* (June 18, 2006), kirkmcd.princeton.edu/examples/EM/slepian_ee_68_245_49
- [148] M.M. Michaelis and A. Forbes, *Laser propulsion: a review*, S. Afr. J. Sci. **102**, 289 (2006), kirkmcd.princeton.edu/examples/EM/michaelis_sajs_102_289_06.pdf
- [149] H.H. Brito and S.A. Elaskar, *Advances in Electromagnetic Inertia Propulsion*, IAC-06-C4.3.10, http://kirkmcd.princeton.edu/examples/EM/brito_iac-06-c4.3.10.pdf

- [150] M.G. Millis and N.E. Thomas, *Responding to Mechanical Antigravity*, NASA/TM-2006-214390, kirkmc.d.princeton.edu/examples/mechanics/millis_TM-2006-214390.pdf
- [151] T.H. Boyer, *Interaction of a point charge and a magnet: Comments on ‘hidden mechanical momentum due to hidden nonelectromagnetic forces*, <http://arxiv.org/abs/0708.3367>
- [152] T.H. Boyer, *Concerning “hidden momentum”*, Am. J. Phys. **76**, 190 (2008), kirkmc.d.princeton.edu/examples/EM/boyer_ajp_76_190_08.pdf
- [153] D.J. Raymond, *Potential Momentum, Gauge Theory, and Electromagnetism in Introductory Physics*, (Feb. 2, 2008), http://arxiv.org/PS_cache/physics/pdf/9803/9803023v1.pdf
- [154] K.T. McDonald, *Electron Trajectories in a Hall Thruster* (Feb. 27, 2008), kirkmc.d.princeton.edu/examples/thruster.pdf
- [155] W. Engelhardt, *The Lorentz Rocket* (May, 2008), http://kirkmc.d.princeton.edu/examples/EM/engelhardt_08.pdf
- [156] K.T. McDonald, *Electromagnetic Fields of a Small Helical Toroidal Antenna* (Dec. 8, 2008), kirkmc.d.princeton.edu/examples/cwhta.pdf
- [157] D. Babson *et al.*, *Hidden momentum, field momentum, and electromagnetic impulse*, Am. J. Phys. **77**, 826 (2009), kirkmc.d.princeton.edu/examples/EM/babson_ajp_77_826_09.pdf
- [158] K.T. McDonald, *Orbital and Spin Angular Momentum of Electromagnetic Fields* (Mar. 12, 2009), kirkmc.d.princeton.edu/examples/spin.pdf
- [159] C. Baxter and R. Loudon, *Radiation pressure and the photon momentum in dielectrics*, J. Mod. Opt. **57**, 830 (2010), http://kirkmc.d.princeton.edu/examples/EM/baxter_jmo_57_830_10.pdf
- [160] S.E. Gralla, A.I. Harte, and R.M. Wald, *Bobbing and kicks in electromagnetism and gravity*, Phys. Rev. D **81**, 104012 (2010), kirkmc.d.princeton.edu/examples/GR/gralla_prd_81_104012_10.pdf
- [161] M.G. Millis, *Progress in Revolutionary Propulsion Physics*, IAC-10-C4.8.7 (2010), kirkmc.d.princeton.edu/examples/EM/millis_iac61_10.pdf
- [162] C.M. Wilson *et al.*, *Observation of the dynamical Casimir effect in a superconducting circuit*, Nature **479**, 376 (2010), kirkmc.d.princeton.edu/examples/QED/wilson_nature_479_376_11.pdf
- [163] R. Iancu, D. Sohar and M. Mudrik, *An analysis of the Browne-Biefeld effect*, J. Elec. **69**, 511 (2011), http://kirkmc.d.princeton.edu/examples/EM/ianconescu_je_69_512_11.pdf
- [164] M. Mansuripur, *Trouble with the Lorentz Law of Force: Incompatibility with Special Relativity and Momentum Conservation*, Phys. Rev. Lett. **108**, 193901 (2012), http://kirkmc.d.princeton.edu/examples/EM/mansuripur_prl_108_193901_12.pdf

- [165] J. Yang *et al.*, *Prediction and experimental measurement of the electromagnetic thrust generated by a microwave thruster system*, Chin. Phys. B **22**, 050301 (2013), kirkmcd.princeton.edu/examples/EM/yang_cpb_22_050301_13.pdf
- [166] S.O. Starr and R.C. Youngquist, *A low voltage “railgun”*, Am. J. Phys. **81**, 38 (2013), kirkmcd.princeton.edu/examples/EM/starr_ajp_81_38_13.pdf
- [167] K.T. McDonald, *Mansuripur’s Paradox* (May 2, 2012), kirkmcd.princeton.edu/examples/mansuripur.pdf
- [168] K.T. McDonald, *Abraham, Minkowski and “Hidden” Momentum* (June 6, 2012), Sec. 2.3, kirkmcd.princeton.edu/examples/abraham.pdf
- [169] K.T. McDonald, *“Hidden” Momentum in an Oscillating Tube of Water* (June 24, 2012), kirkmcd.princeton.edu/examples/utube.pdf
- [170] K.T. McDonald, *“Hidden” Momentum in a Link of a Moving Chain* (June 28, 2012), kirkmcd.princeton.edu/examples/link.pdf
- [171] D. Vanzella, *Hidden momentum of (possibly open) systems* (June 29, 2012), kirkmcd.princeton.edu/examples/EM/vanzella_120629.pdf
- [172] K.T. McDonald, *“Hidden” Momentum in a Current Loop* (June 30, 2012), kirkmcd.princeton.edu/examples/penfield.pdf
- [173] K.T. McDonald, *“Hidden” Momentum in a River* (July 5, 2012), kirkmcd.princeton.edu/examples/river.pdf
- [174] K.T. McDonald, *On the Definition of “Hidden” Momentum* (July 9, 2012), kirkmcd.princeton.edu/examples/hiddendef.pdf
- [175] K.T. McDonald, *“Hidden” Momentum in a Spinning Sphere* (Aug. 16, 2012), kirkmcd.princeton.edu/examples/spinningsphere.pdf
- [176] K.T. McDonald, *“Hidden” Momentum in a Linked Pair of Gyrostats* (Aug. 17, 2012), kirkmcd.princeton.edu/examples/gyrostat.pdf
- [177] K.T. McDonald, *Center of Mass of a Relativistic Rolling Hoop* (Sept. 7, 2012), kirkmcd.princeton.edu/examples/hoop.pdf
- [178] M. Tuval and A. Yahalom, *Newton’s Third Law in the Framework of Special Relativity* (Jan. 26, 2013), <http://arxiv.org/abs/1302.2537>
Eur. Phys. J. Plus **129**, 240 (2014), http://kirkmcd.princeton.edu/examples/EM/tuval_epjp_129_240_14.pdf
- [179] H. Fearn and J.F. Woodward, *Experimental null test of a Mach effect thruster*, J. Space Expl. **2**, 93 (2013), http://kirkmcd.princeton.edu/examples/EM/fearn_jse_2-2_98_13.pdf
- [180] J. Franklin, *The electromagnetic momentum of static charge-current distributions*, Am. J. Phys. **82**, 869 (2013), kirkmcd.princeton.edu/examples/EM/franklin_ajp_82_869_14.pdf

- [181] E. Moreau *et al.*, *Electrohydrodynamic force produced by a wire-to-cylinder dc corona discharge in air at atmospheric pressure*, J. Phys. D **46**, 475204 (2012), http://kirkmcd.princeton.edu/examples/EM/moreau_jpd_46_475204_13.pdf
- [182] E.D. Fylladitakis, M.P. Theodoridis and A.X. Moronis, *Review on the History, Research, and Applications of Electrohydrodynamics*, IEEE Trans. Plasma Sci. **42**, 358 (2014), kirkmcd.princeton.edu/examples/EM/fylladitakis_ieeetps_42_358_14.pdf
- [183] D. Muller (Veritasium), *Anti-Gravity Wheel Explained* (Mar. 19, 2014), <https://www.youtube.com/watch?v=tLMpdBjA2SU>
Includes a clip from Laithwaite’s controversial 1974 lecture [73], starting at 0:59.
- [184] M. Einat and R. Kalderon, *High efficiency Lifter based on the Biefeld-Brown effect*, AIP Adv. **4**, 077120 (2014), kirkmcd.princeton.edu/examples/EM/einat_aipa_4_077120_14.pdf
- [185] K.T. McDonald, *J.J. Thomson and “Hidden” Momentum* (Apr. 30, 2014), kirkmcd.princeton.edu/examples/thomson.pdf
- [186] T.H. Boyer, *Classical interaction of a magnet and a point charge: The Shockley-James paradox*, Phys. Rev. E **91**, 013201 (2015), kirkmcd.princeton.edu/examples/EM/boyer_pre_91_013201_15.pdf
- [187] T.H. Boyer, *Interaction of a magnet and a point charge: Unrecognized internal electromagnetic momentum*, Am. J. Phys. **83**, 433 (2015), kirkmcd.princeton.edu/examples/EM/boyer_ajp_83_433_15.pdf
- [188] D.J. Griffiths and V. Hnizdo, *Comment on “The electromagnetic momentum of static-charge distributions”*, Am. J. Phys. **83**, 279 (2015), kirkmcd.princeton.edu/examples/EM/griffiths_ajp_83_279_15.pdf
- [189] K.T. McDonald, *Forces on Magnetic Dipoles* (Oct. 26, 2014), kirkmcd.princeton.edu/examples/neutron.pdf
- [190] T. Laffleur, *Can the quantum vacuum be used as a reaction medium to generate thrust?* (Nov. 19,, 2014), <https://arxiv.org/abs/1411.5359>
- [191] C.K. Gilmore and S.R.H. Barrett, *Electrohydrodynamic thrust density using positive corona-induced ionic winds for in-atmosphere propulsion*, Proc. Roy. Soc. London A **471**, 20140912 (2015), http://kirkmcd.princeton.edu/examples/EM/gilmore_prsla_471_20140912_15.pdf
- [192] K.T. McDonald, *Electromagnetic Field Angular Momentum of a Charge at Rest in a Uniform Magnetic Field* (Dec. 21, 2014), kirkmcd.princeton.edu/examples/lfield.pdf
- [193] K.T. McDonald, *Bibliography on the Abraham-Minkowski Debate* (Feb. 17, 2015), kirkmcd.princeton.edu/examples/ambib.pdf
- [194] K.T. McDonald, *“Hidden” Momentum in a Magnetized Toroid* (Mar. 29, 2015), kirkmcd.princeton.edu/examples/toroid_cap.pdf

- [195] K.T. McDonald, “Hidden” Momentum in a Charge, Rotating Disk (Apr. 6, 2015), kirkmc.d.princeton.edu/examples/rotatingdisk.pdf
- [196] K.T. McDonald, *Birkeland and Poincaré: Motion of an Electric Charge in the Field of a Magnetic Pole* (Apr. 15, 2015), kirkmc.d.princeton.edu/examples/birkeland.pdf
- [197] M. Tuval and A. Yahalom, *Relativistic Engine Based on a Permanent Magnet* (June 30, 2015), <http://arxiv.org/abs/1507.02897>
A. Yahalom, *Retardation in Special Relativity and the Design of a Relativistic Motor*, Acta Phys. Pol. A **131**, 1285 (2017), http://kirkmc.d.princeton.edu/examples/EM/yahalom_appa_131_1285_17.pdf
- [198] E.B. Porcelli and V. dos Santos Filho, *Characterisation of anomalous forces on asymmetric high-voltage capacitors*, IET Sci. Meas. Tech. **10**, 383 (2015), kirkmc.d.princeton.edu/examples/EM/porcelli_ietsmt_10_383_16.pdf
- [199] K.T. McDonald, *Capacitor-Driven Railgun: Magnetic Fields Doing Work* (Dec. 28, 2015), kirkmc.d.princeton.edu/examples/railgun.pdf
- [200] K.T. McDonald, *Tuval’s Electromagnetic Spaceship* (Nov. 30, 2015), kirkmc.d.princeton.edu/examples/tuval.pdf
- [201] R. Shawyer, *Second generation EmDrive propulsion applied to SSTO launcher and interstellar probe*, Acta Astro. **116**, 166 (2015), kirkmc.d.princeton.edu/examples/EM/shawyer_aa_116_166_15.pdf
- [202] K.T. McDonald, *Electromagnetic Helicopter?* (Jan. 25, 2016), kirkmc.d.princeton.edu/examples/helicopter.pdf
- [203] H. White *et al.*, *Measurement of Impulsive Thrust from a Closed Radio-Frequency Cavity in Vacuum*, J. Prop. Power **33**, 830 (2017), kirkmc.d.princeton.edu/examples/EM/white_jpp_16.pdf
- [204] F. Redfern, *Magnets in an electric field: hidden forces and momentum conservation*, Eur. Phys. J. D **71**, 163 (2017), kirkmc.d.princeton.edu/examples/EM/redfern_epjd_71_163_17.pdf
- [205] F. Redfern, *Hidden momentum: A misapplication of the center of energy theorem* (November, 2016), <https://www.researchgate.net/publication/309661435>
- [206] K.T. McDonald, *Electromagnetic Self-Force on a Hemispherical Cavity* (Nov. 27, 2016), kirkmc.d.princeton.edu/examples/hemisphere.pdf
- [207] M. Partanen *et al.*, *Photon mass drag and the momentum of light in a medium*, Phys. Rev. A **95**, 063850 (2017), kirkmc.d.princeton.edu/examples/EM/partanen_pra_95_063850_17.pdf
- [208] K.T. McDonald, *Little’s Paradox* (Apr. 21, 2017), kirkmc.d.princeton.edu/examples/little.pdf
- [209] J. Franklin, *What is the force on a magnetic dipole?* Eur. J. Phys. **39**, 035201 (2018), kirkmc.d.princeton.edu/examples/EM/franklin_ejp_39_035201_18.pdf

- [210] M. Tajmar *et al.*, *The SpaceDrive Project First Results on EMDrive and Mach-Effect Thrusters* (May 14, 2018), kirkmcd.princeton.edu/examples/EM/tajmar_sp2018-016.pdf
- [211] K.T. McDonald, *No Bootstrap Spaceships via Magnets in Electric Fields* (Aug. 16, 2018), kirkmcd.princeton.edu/examples/redfern.pdf
- [212] R.E. Bishop and V. Onoichin, *Usage of the retardation effect to design the thruster based on another than action-reaction principle* (2018), kirkmcd.princeton.edu/examples/bishop_thruster.pdf
- [213] K.T. McDonald, *The Electric Self Force on a Current Loop* (Jan. 11, 2019), kirkmcd.princeton.edu/examples/loop_force.pdf
- [214] J.P. McClymer, *Reactionless drive with conservation of momentum* (February 14, 2019), arxiv.org/abs/1902.07293
- [215] K.T. McDonald, *McClymer's Electromagnetic Spaceship* (Feb. 23, 2019), kirkmcd.princeton.edu/examples/mcclymer.pdf
- [216] K.T. McDonald, *Engelhardt's Electromagnetic Spaceship* (Feb. 5, 2020), kirkmcd.princeton.edu/examples/engelhardt.pdf
- [217] M. Tajmar and T. Schreiber, *Put strong limits on all proposed theories so far assessing electrostatic propulsion: Does a charged high-voltage capacitor produce thrust?*, *J. Elec.* **107**, 103477 (2020), http://kirkmcd.princeton.edu/examples/EM/tajmar_je_107_103477_20.pdf