

Muon Collider main page:

http://www.cap.bnl.gov/mumu/mu_home_page.html

My muon collider page:

<http://www.hep.princeton.edu/~mcdonald/mumu>

Continuing the Miracle of Creation

- Basic theme of high-energy physics:

Understand nature via creation of new particles.

⇒ Pursue the **energy frontier**.

- But it takes big machines to reach high energies.

Can/will our society bear the costs?

- Hadron collider (LHC, SSC): \approx \$100k/m [superconducting magnets].
- e^+e^- collider (SLAC, NLC(?): \approx \$200k/m [rf].

Are there other options?

- Muon collider:

Well-defined leptonic initial state.

$m_\mu/m_e \approx 200 \Rightarrow$ Little beam radiation.

\Rightarrow Can use storage rings.

\Rightarrow Smaller footprint.

Technology: closer to hadron colliders.

Ingredients of a Muon Collider?

An accelerator complex in which

- Muons (both μ^+ and μ^-) are collected from pion decay following a pN interaction.
- The muon phase volume is reduced by ionization cooling.
- The cooled muons are accelerated and then stored in a ring.
- $\mu^+\mu^-$ collisions are observed over the useful muon life of ≈ 1000 turns at any energy.

Muons decay: $\mu \rightarrow e\nu \quad \Rightarrow$

- Must cool muons quickly (stochastic cooling won't do).
- Detector backgrounds at LHC level.
- Personnel background from ν interactions.

Footprints

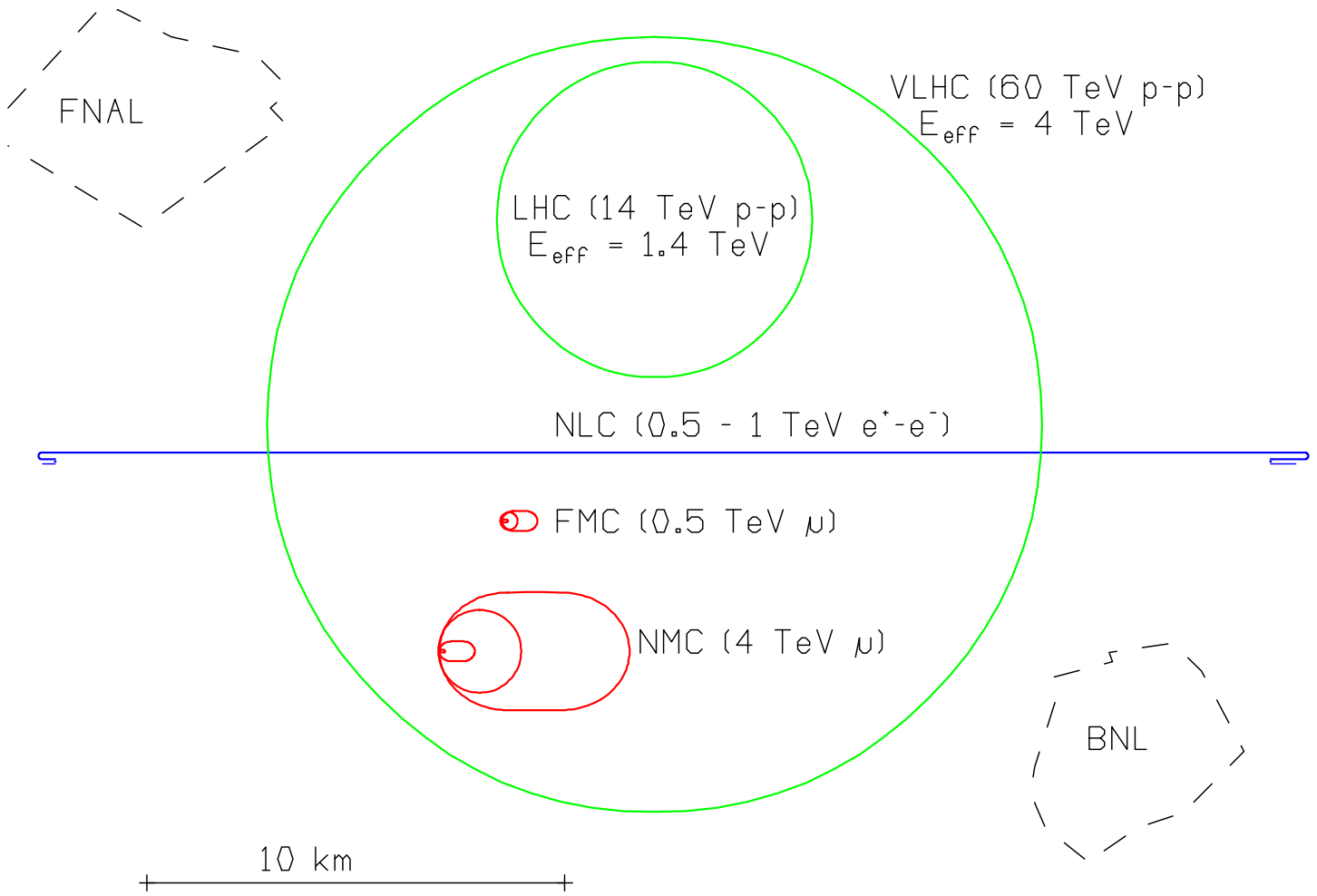

Muon collider:

- Significant base cost ($\approx \$1\text{B}$) at any energy, plus ‘modest’ cost ($\approx \$100\text{k/m}$) for storage rings.
- Up to 4 TeV on existing sites at cost below LHC.
- Technology path to $\approx 100 \text{ TeV}$ before limited by radiation losses.

Footprints

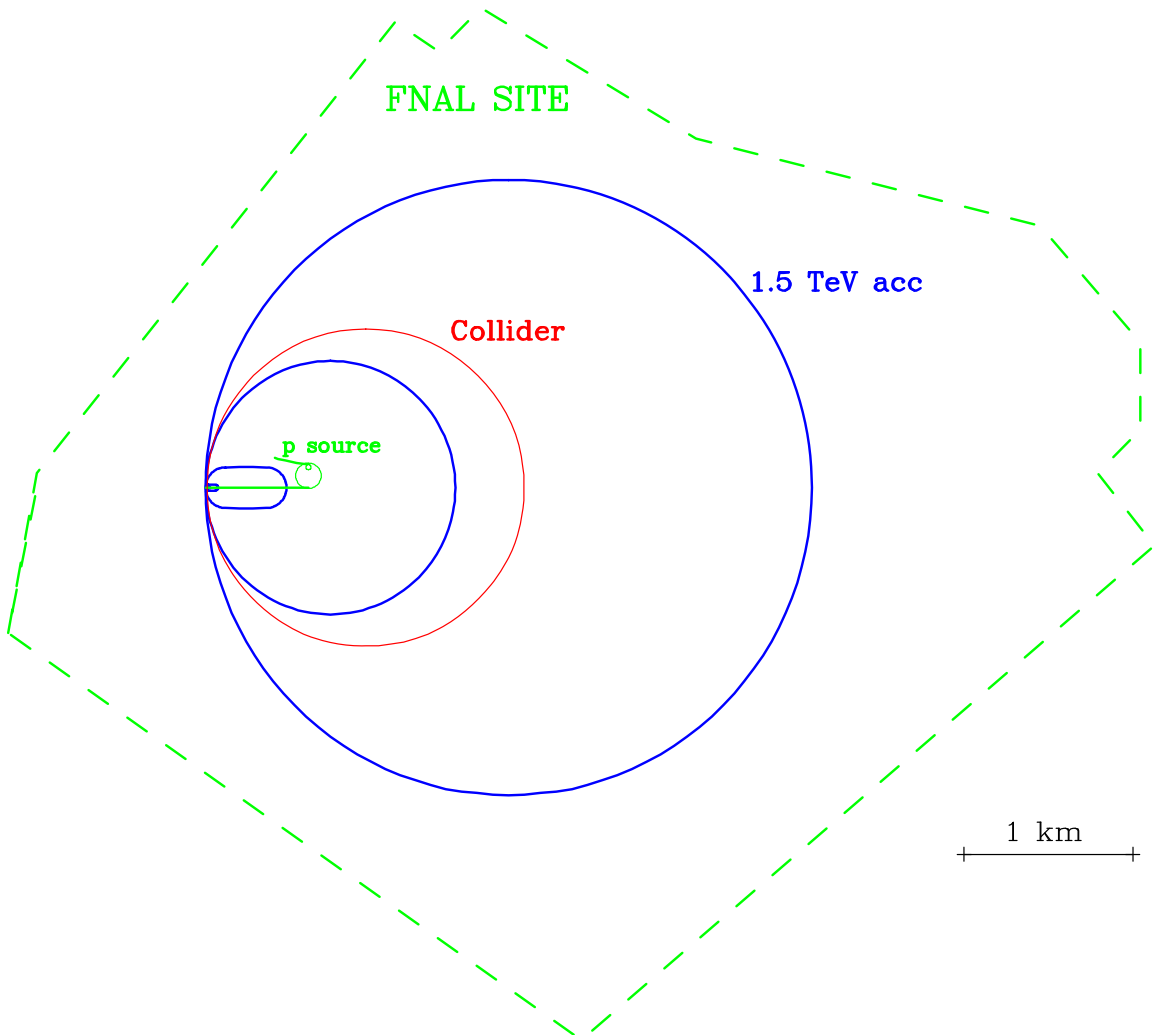
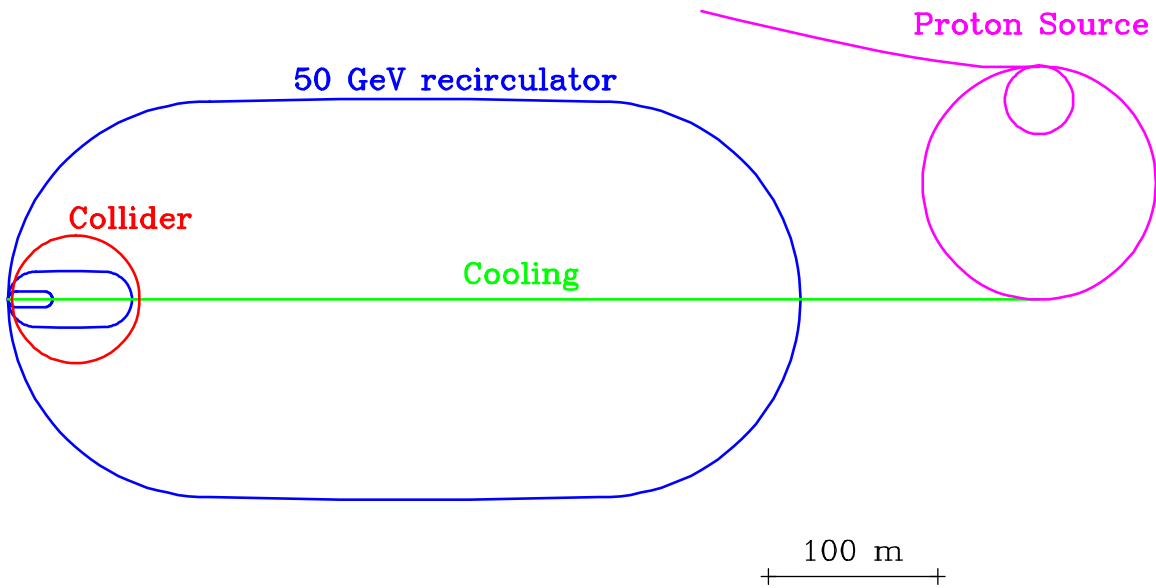

Physics Opportunities

- Full CoM energy available for particle production.
- Beam energy spread: 10^{-5} at 100 GeV, 10^{-3} at 3 TeV.
- “Natural” beam polarization $\approx 20\%$ from π -decay at 200 MeV/c.

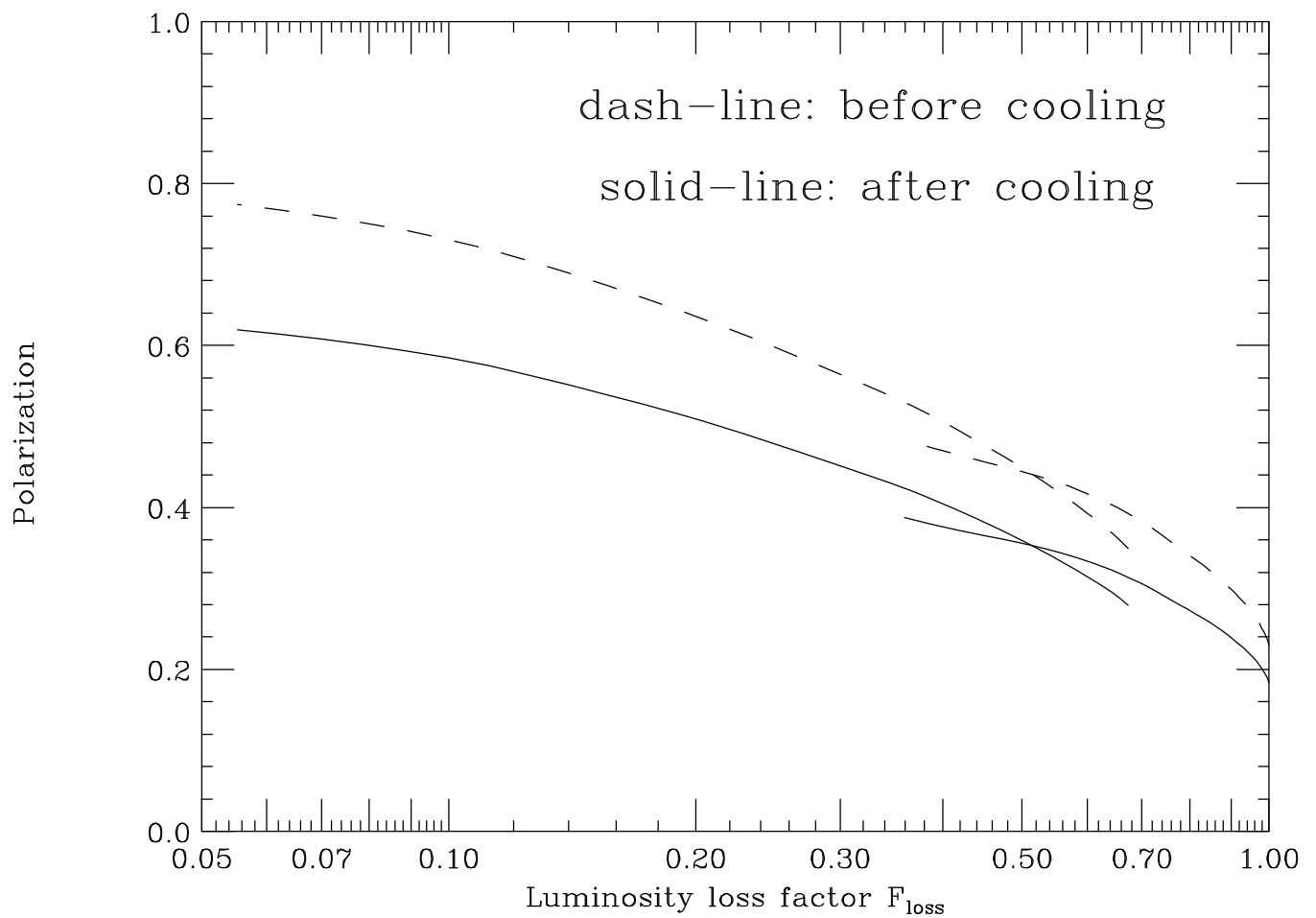

Precision Beam Energy Measurement

Via decay asymmetry of polarized muons.

[Raja and Tollestrup, FERMILAB-Pub-97/402]

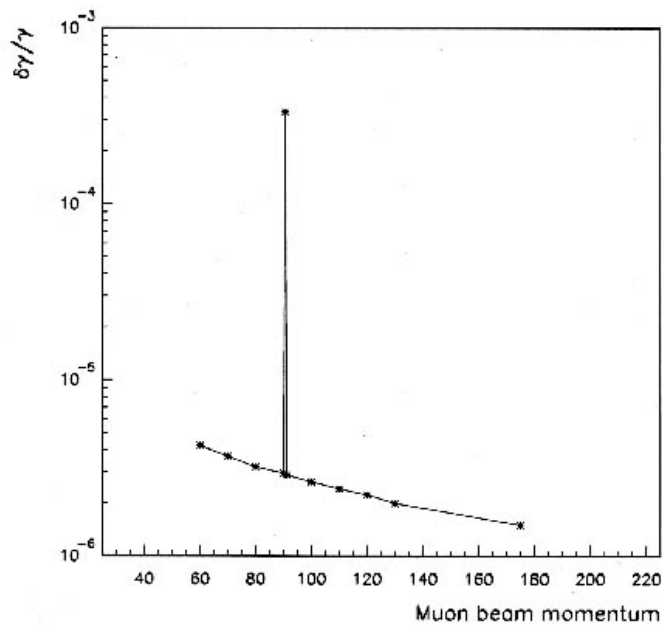
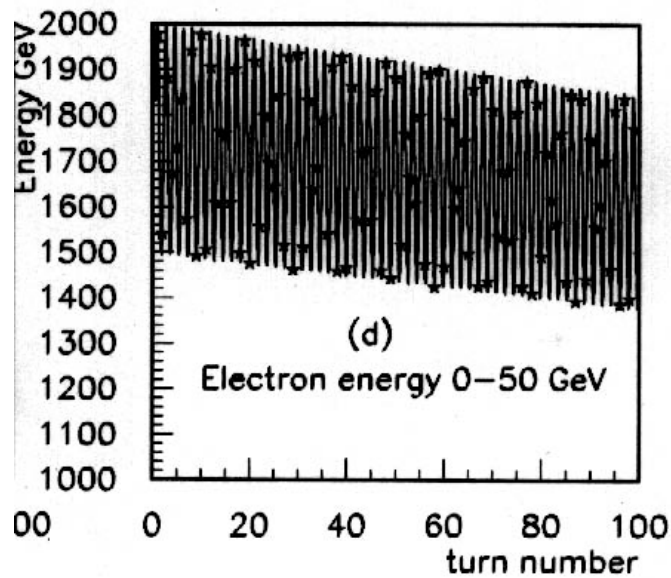

\Rightarrow Can measure width (2 MeV) of light Higgs.

Physics Backgrounds

1. Electrons (+ photons) from μ decay:

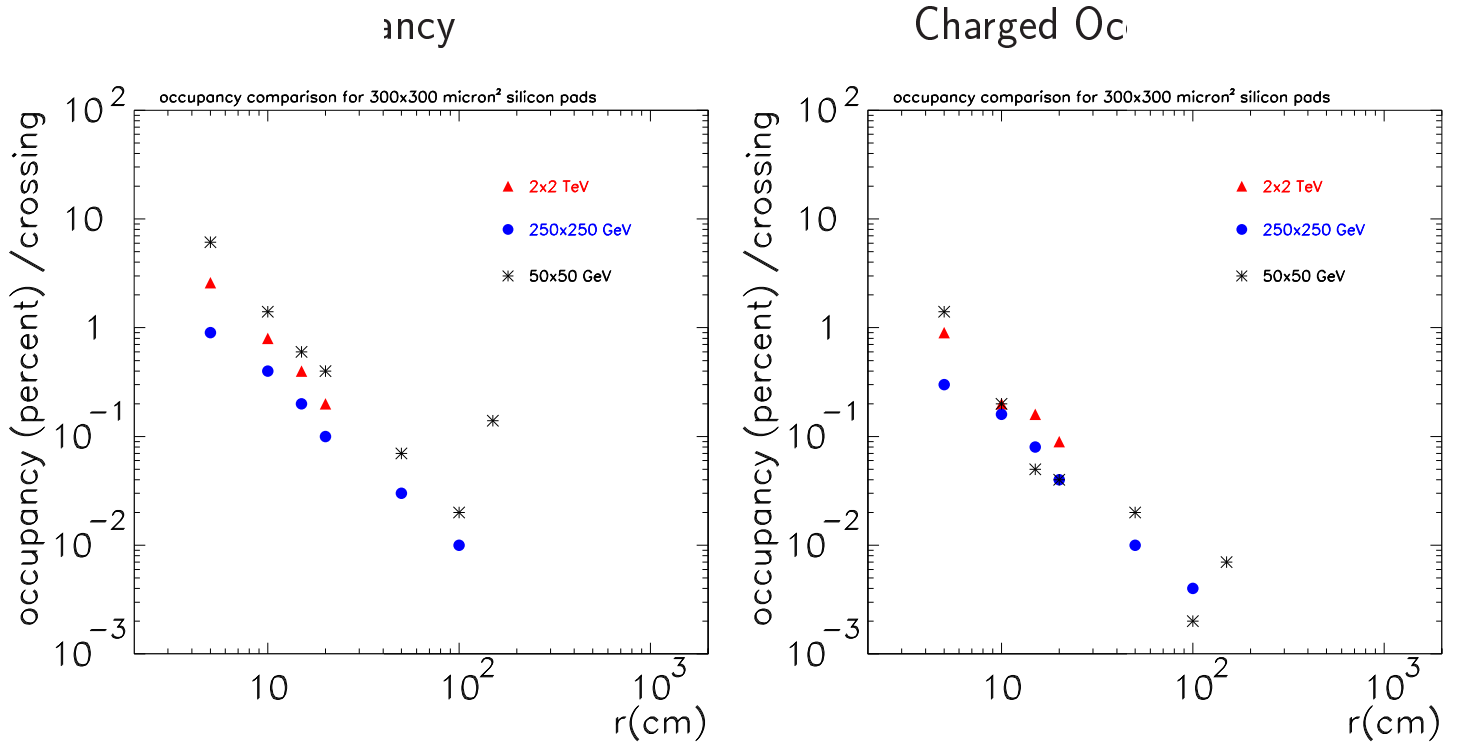

O.K., if use pixel vertex detector.

Radial Fluences at 2x2 TeV

particles/cm²/crossing for two bunches of $10^{12}\mu$'s each

radius (cm)	photons	neutrons	protons	pions	electrons	muons
5	2700	120	0.05	0.9	2.3	1.7
10	750	110	0.20	0.4		0.7
15	350	100	0.13	0.4		0.4
20	210	100	0.13	0.3		0.1
50	70	120	0.08	0.05		.02
100	31	50	0.04	0.003		.008
calo						.003
muon						.0003
threshold	25	40	10	10		
	keV	keV	MeV	MeV		

2. ‘Bethe-Heitler’ muons [$\mu \rightarrow e \rightarrow \gamma \rightarrow \mu^+ \mu^-$]:

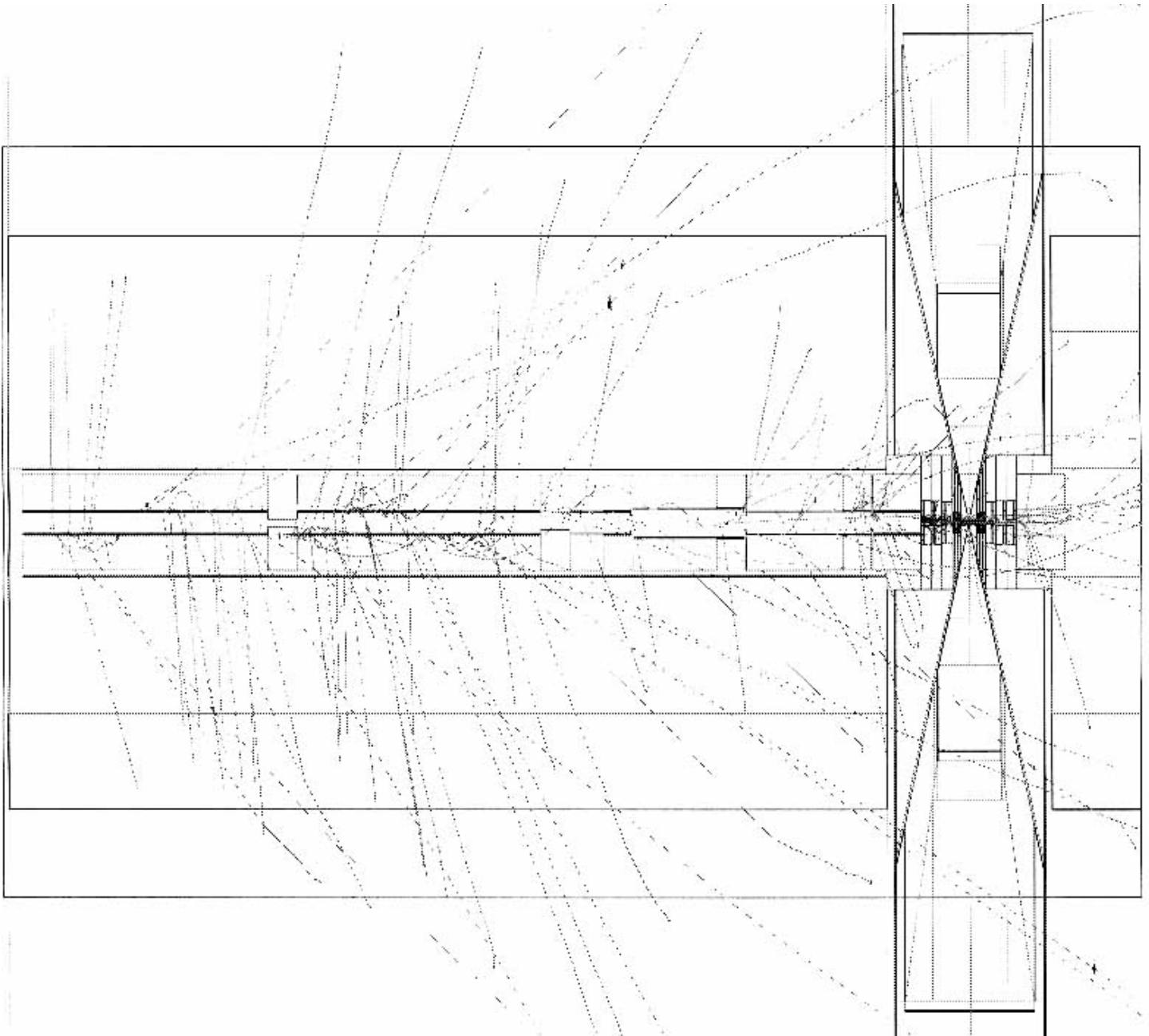

Affects calorimeter performance at CoM energies above 1 TeV.

[Iuliu Stumer]

Dose from Neutrino Interactions

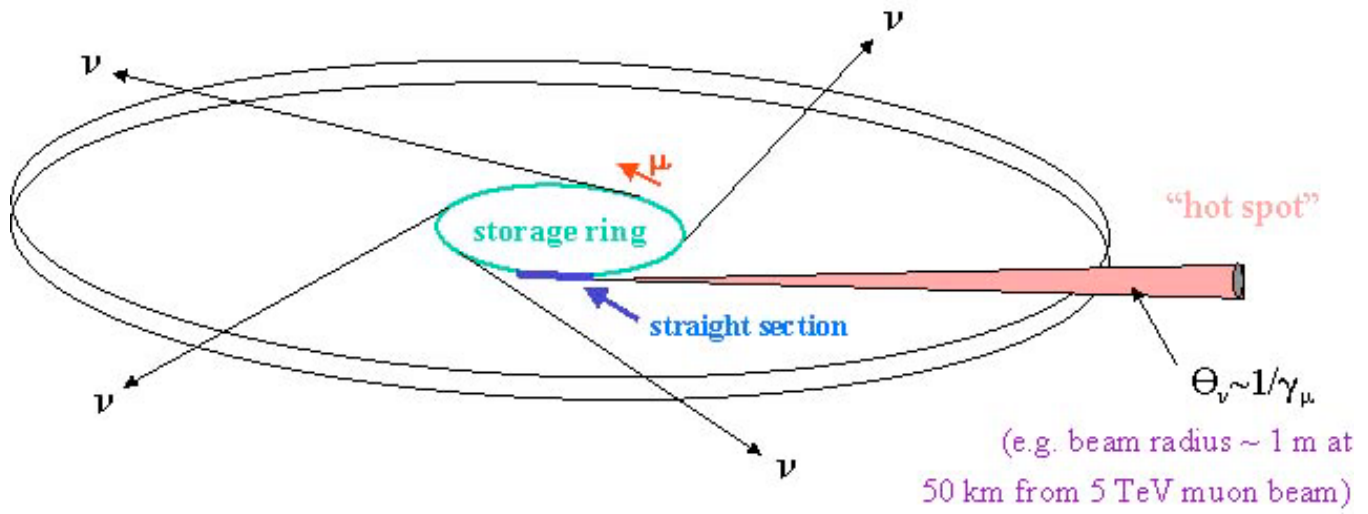

Much worse at straight sections: e.g. even 0.1 m str. section is \sim twice disk ave.

Hazard is charged particles from ν interactions in surroundings...

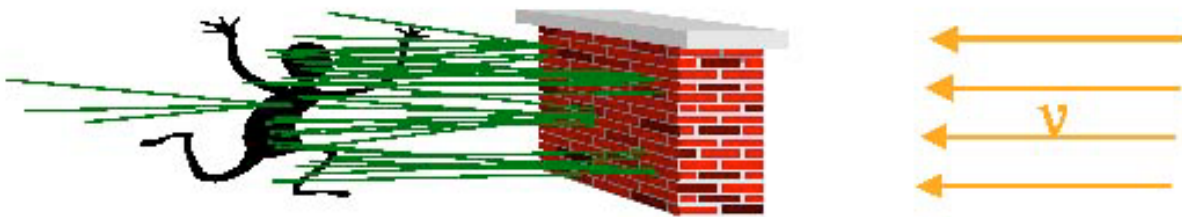

Predicted dose downstream from straight section:

$$\frac{\text{Radiation Dose}}{\text{U.S. Fed. Limit}} \cong 0.4 \times \left(\frac{\text{length of str. section}}{\text{collider depth}} \right) \times \left(\frac{\text{muon current}}{10^{20} \mu^-/\text{year}} \right) \times \left(\frac{E_{\text{CoM}}}{1 \text{ TeV}} \right)^3$$

(spherical Earth & non-tilted ring)



Neutrino Problem ‘Stabilizes’ above 10 Tev

- Neutrino cross section levels off at high energy:

$$\frac{\sigma(E_\nu = 100 \text{ TeV})}{\sigma(E_\nu = 1 \text{ TeV})} = 33, \quad (\text{rather than } 100).$$

- Previous formula overestimates dose once ν spot is smaller than 1 m.
- Better cooling schemes will permit low emittance for smaller muon beam current.
- \Rightarrow May never need ring deeper than 500 m.

Neutrino Physics at a Muon Collider

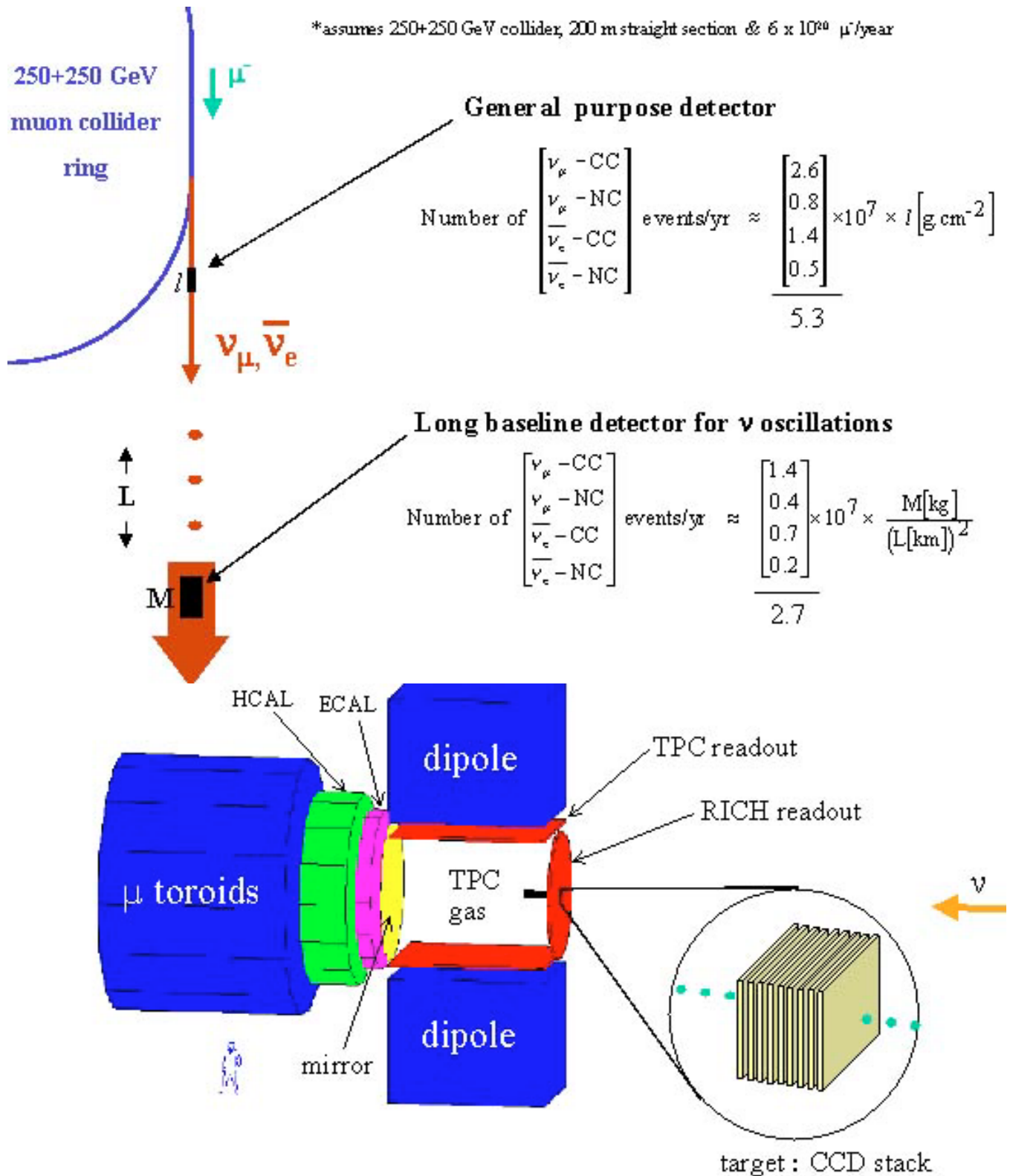

- **HUGE statistics: 50 g/cm^2 target $\Rightarrow 3 \times 10^9$ events/year**
- **outstanding reconstruction of CC & NC event kinematics**
- **full particle ID \Rightarrow ID of struck quark**

Muon Collider Parameters

CoM energy	TeV	3	0.4				0.1
<i>p</i> energy	GeV	16	16				16
<i>p</i> 's/bunch		2.5×10^{13}	2.5×10^{13}				5×10^{13}
Bunches/fill		4	4				2
Rep. rate	Hz	15	15				15
<i>p</i> power	MW	4	4				4
μ /bunch		2×10^{12}	2×10^{12}				4×10^{12}
μ power	MW	28	4				1
Wall power	MW	204	120				81
Collider circumf.	m	6000	1000				300
Depth	m	500	100				10
$\frac{\Delta p}{p}$ (rms)	%	0.16	0.14	0.12	0.01		0.003
6D ϵ_6	$(\pi\text{mm})^3$	170	170	170	170		170
ϵ_n (rms)	π mm mrad	50	50	85	195		280
β^*	cm	0.3	2.3	4	9		13
σ_z	cm	0.3	2.3	4	9		13
σ_r	μm	3.2	24	82	187		270
Tune shift		0.043	0.043	0.05	0.02		0.015
Luminosity	$\text{cm}^{-2}\text{s}^{-1}$	5×10^{34}	10^{33}	1.2×10^{32}	2×10^{31}		10^{31}
CoM $\frac{\Delta E}{E}$		8×10^{-4}	8×10^{-4}	8×10^{-4}	7×10^{-5}		2×10^{-5}
Higgs/year					1,600	4,000	4,000

Technical Challenges

- 16-GeV proton driver, 15 Hz, 4-MW beam power,
1-ns bunch length.

		Linac	Pre-Booster	Booster
Final energy	GeV	1.0	4.5	16
Protons/bunch			5×10^{13}	5×10^{13}
No. of bunches			2	2
Rep. rate	Hz	15	15	15
Circumference	m		180.6	474.2
Norm. 95% emit.	π mm mrad		200	240
Sp.-ch. tune shift			.39	.39
Final field	T		1.3	1.3

- Targetry and Capture
- **Muon Cooling**

[Storage rings have beautiful, highly corrected solutions due to heroic work of Al Garren, Carol Johnstone and Dan Trbojevič.]

Overview of Targetry for a Muon Collider

- Get muons from pion decay: $\pi^\pm \rightarrow \mu^\pm \nu$.
- Pions from proton-nucleus interactions in a **target**.
- Goal: $1.2 \times 10^{14} \mu^\pm/\text{s}$.
- \Rightarrow High- Z target,
High-energy proton beam,
High magnetic field around target to capture soft pions.
- $\mu/p = 0.08$ at 16 GeV $\Rightarrow 1.5 \times 10^{15} p/\text{s}$.
- 15-Hz proton source.
- 4 MW power in p beam.
- Compare: 0.1 MW in 900-GeV extracted p beam at FNAL;
0.25 MW in 30-GeV extracted beam at BNL AGS.

Baseline Scenario

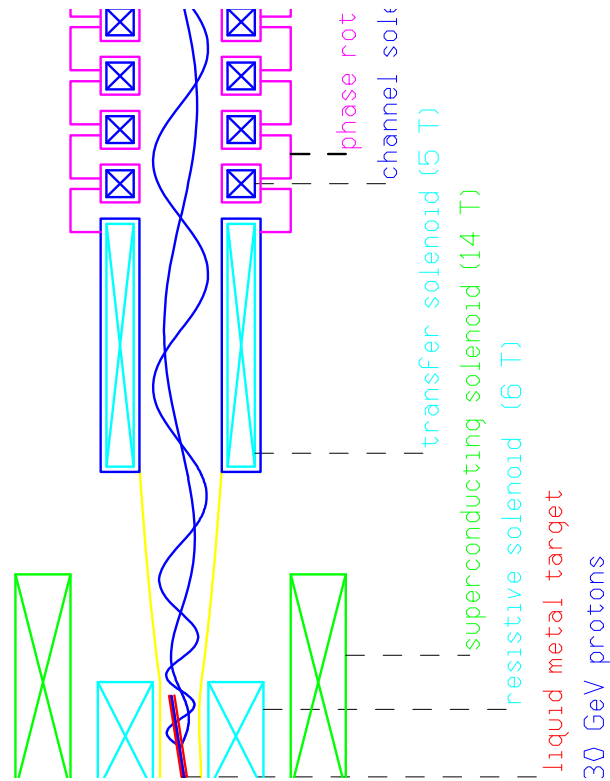

- Liquid metal target: Ga, Hg, or solder (Bi/In/Pb/Sn alloy)
- 20-T capture solenoid followed by 5-T phase-rotation channel.
- 20 T = 8-T, 8-MW water-cooled Cu magnet
+ 12-T superconducting magnet.
- Cost of 12-T magnet $\approx 0.8 \text{ M\$ } (B[\text{T}] R[\text{m}])^{1.32} (L[\text{m}])^{0.66}$
 $\approx \$6\text{M}$.

- Capture pions with $P_{\perp} < 220 \text{ MeV}/c$.
- Adiabatic invariant: $\Phi = \pi r^2 B$ as B drops from 20 to 5 T.
- $r = P_{\perp}/eB =$ radius of helix.
- $\Rightarrow P_{\perp,f} = P_{\perp,i} \sqrt{B_f/B_i} = 0.5$ (and $P_{\parallel,f} > P_{\parallel,i}$).
- Tilt target by ≈ 0.1 rad to minimize absorption of spiralling pions (factor of 2 effect).
- Target should be short and narrow,
 \Rightarrow high density; no cooling jacket.
- High power of beam + radiation damage would crack stationary target.
 - 10% of beam energy deposited in target $\Rightarrow 30 \text{ kJ/pulse}$.
 - $M_{\text{target}} = \pi r^2 l \rho \approx 10 \text{ kg} \Rightarrow \approx 0.1 \text{ eV/atom/pulse}$.
 - 10% of TNT \Rightarrow Shock damage.
 - 1% of atoms ionized each pulse \Rightarrow embrittlement....
- \Rightarrow **Pulsed heavy-metal liquid jet** as target.

Target Optimization via MARS Code

Yield *vs.* Beam Energy

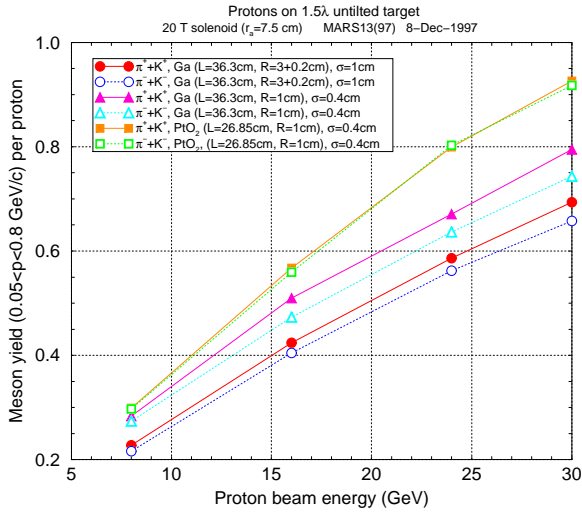

Yield *vs.* Magnetic Field

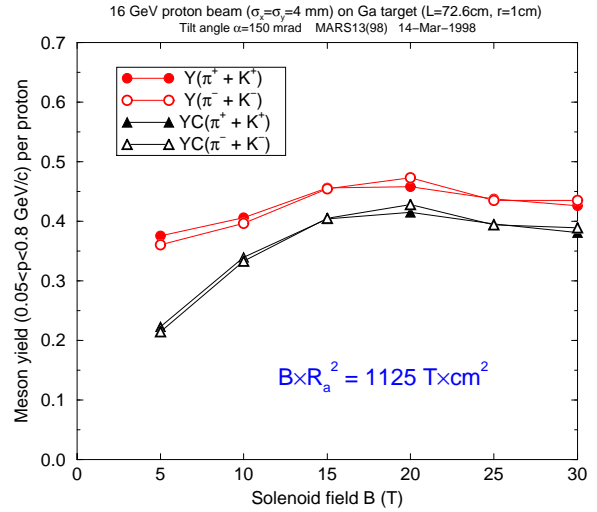

Yield *vs.* Target Radius

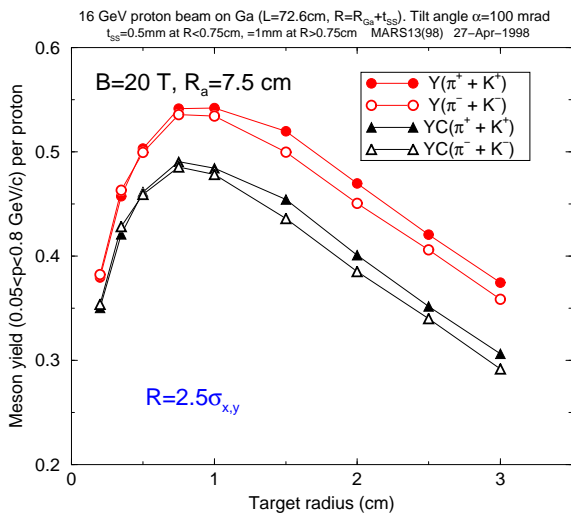

Yield *vs.* Target Angle

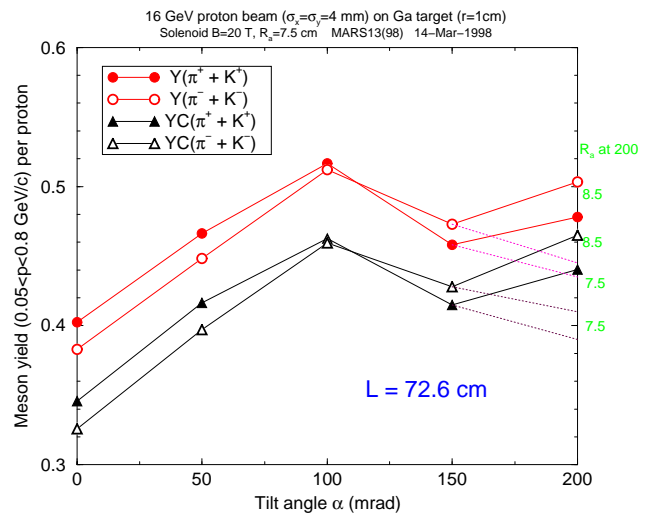

[Nikolai Mokhov, <http://www-ap.fnal.gov/MUMU/mumu.html>]

High Radiation Dose Around Target

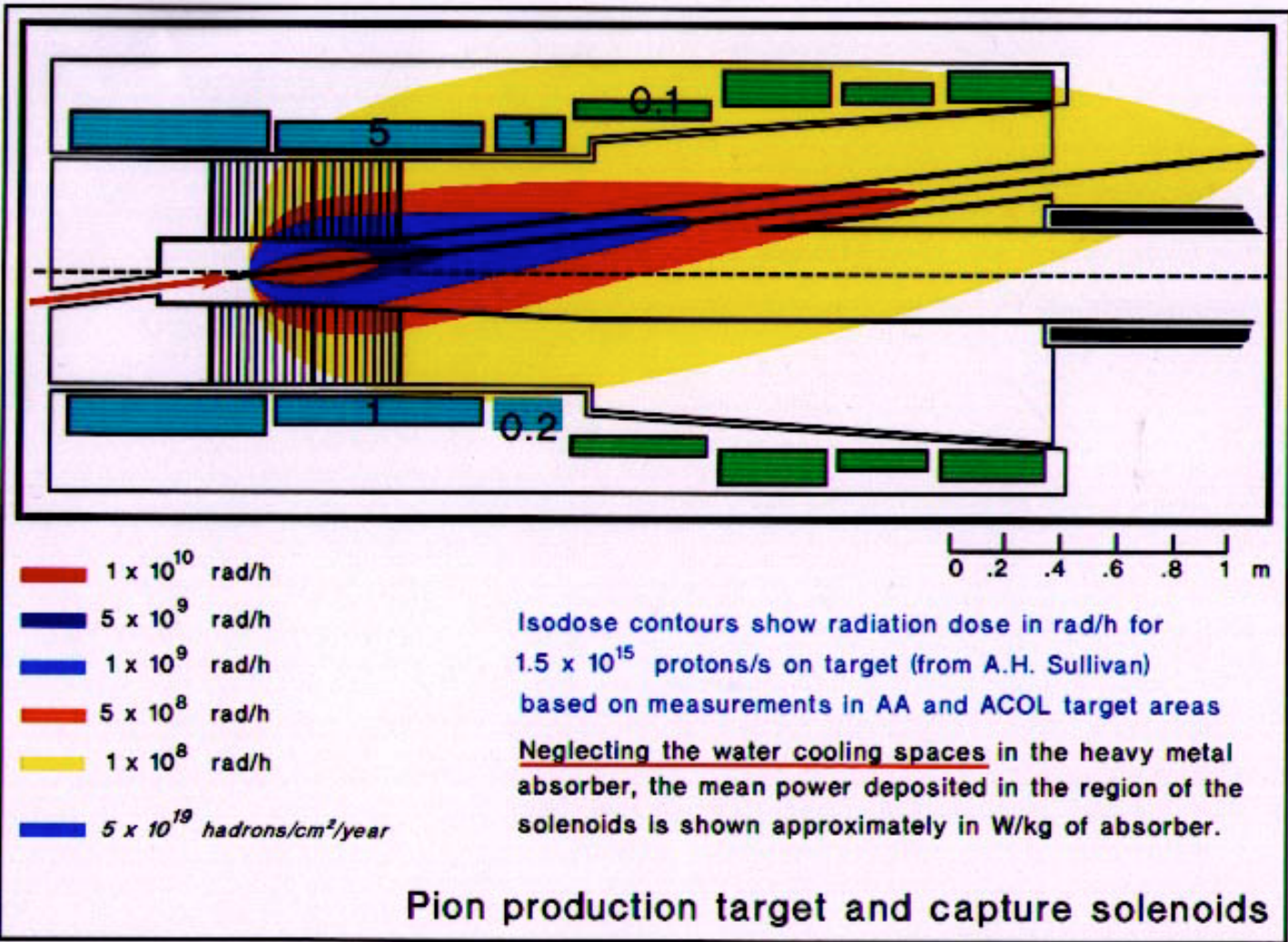

Mercury Jet Studied at CERN

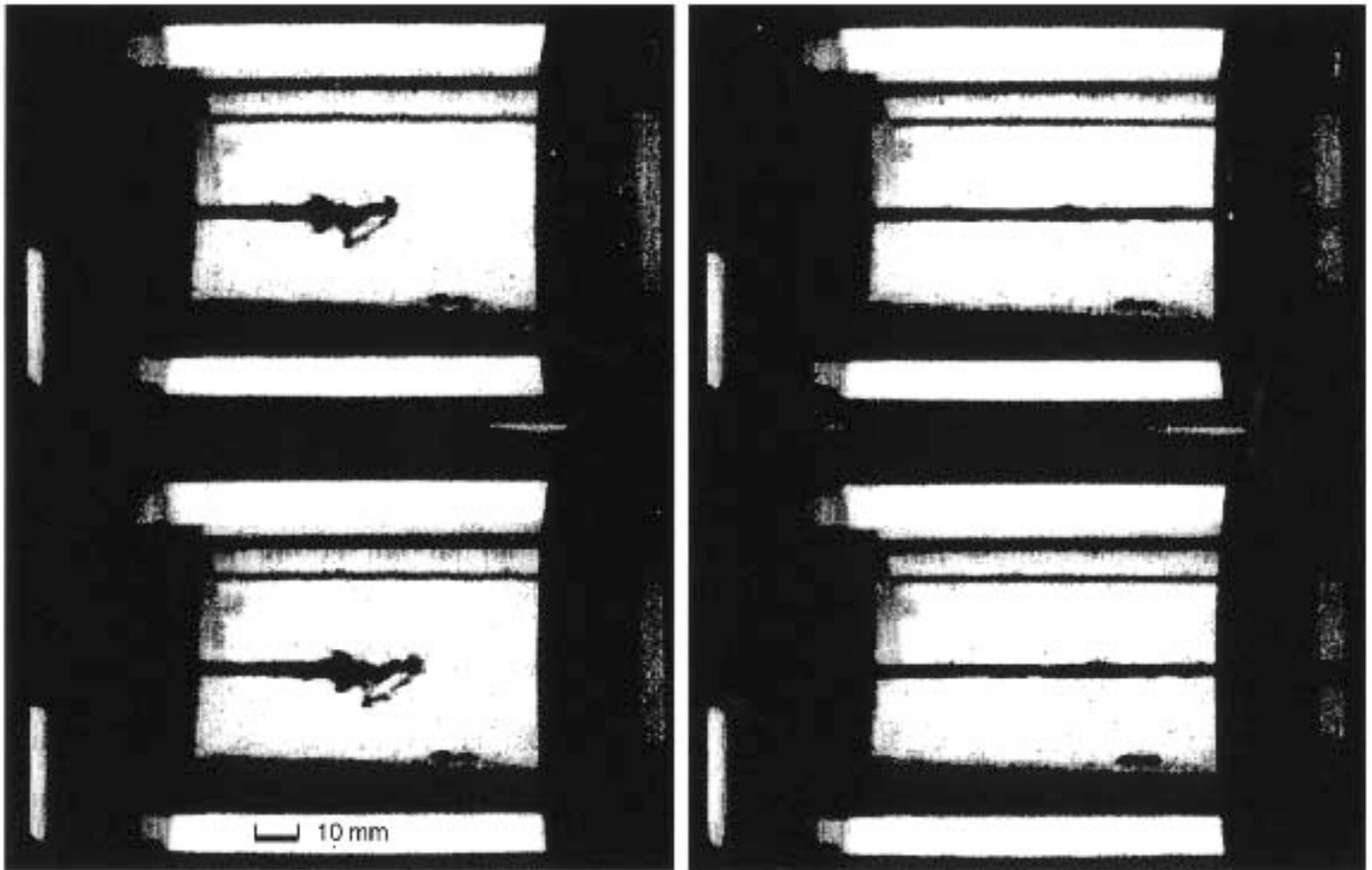

High-speed photographs of mercury jet target for CERN-PS-AA. (laboratory test)
4,000 frames per second, Jet speed: 20 ms^{-1} , diameter: 3 mm, Reynold's Number: $>100,000$
A. Poncelet

Colin Johnson has joined the muon collider targetry group.

Eddy Current Effects on Conducting Liquid Jets

- In frame of jet, changing magnetic field induces eddy currents.
- Lenz: Forces on eddy current oppose motion of jet.
- Longitudinal drag force \Rightarrow won't penetrate magnet unless jet has a minimum velocity: $\sigma = \sigma_{\text{Cu}}/60$, $\rho = 10 \text{ g/cm}^3$, \Rightarrow

$$v_{\min} > 60 \text{ m/s} \left[\frac{r}{1 \text{ cm}} \right] \left[\frac{r}{D} \right] \left[\frac{B_0}{20 \text{ T}} \right]^2.$$

Ex: $B_0 = 20 \text{ T}$, $r = 1 \text{ cm}$, $D = 20 \text{ cm}$, $\Rightarrow v_{\min} = 3 \text{ m/s}$.

- Drag force is larger at larger radius \Rightarrow planes deform into cones:

$$\frac{\Delta z(r)}{r} \approx -3\alpha \left[\frac{r}{1 \text{ cm}} \right] \left[\frac{B_0}{20 \text{ T}} \right]^2 \left[\frac{10 \text{ m/s}}{v} \right].$$

Ex: $\alpha = L/D = 2$, $r = 1 \text{ cm}$, $v = 10 \text{ m/s}$ $\Rightarrow \Delta z = 6 \text{ cm}$.

- Radial pressure: compression as jet enters magnet, expansion as it leaves:

$$P \approx 50 \text{ atm.} \left[\frac{r}{1 \text{ cm}} \right] \left[\frac{r}{D} \right] \left[\frac{B_0}{20 \text{ T}} \right]^2 \left[\frac{v}{10 \text{ m/s}} \right].$$

Ex: $P = 2.5 \text{ atm}$ for previous parameters.

- Will the jet break up into droplets?
- Need both FEA analysis and **lab tests**.

Phase Rotation Channel

- Capture pions with large ΔE about $E \approx 150$ MeV.
- Squeeze energy in linac phased for zero gain at 150 MeV.
- RF cavities interspersed with 5-T magnets.

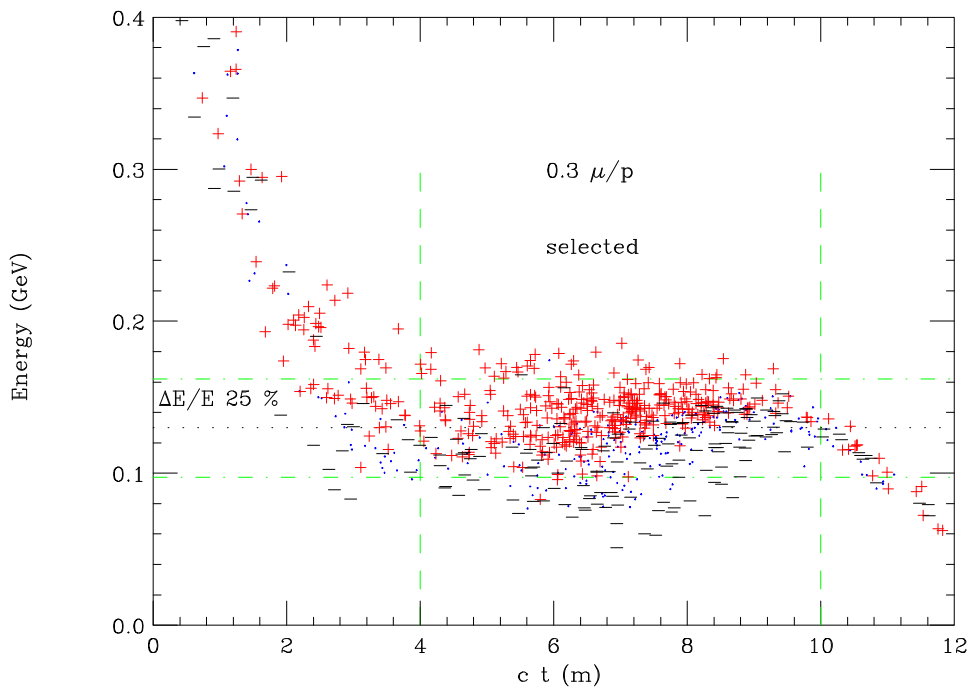

[+ \leftrightarrow positive polarization, - \leftrightarrow negative]

Linac	Length m	Frequency MHz	Gradient MeV/m
1	3	60	5
2	29	30	4
3	5	60	4
4	5	37	4

Ionization Cooling

- Need to reduce 6-D phase volume of muon beam by 10^5 - 10^6 .
- No time for stochastic cooling.
- Ionization: takes momentum away
- RF acceleration: puts momentum back along z axis.
- \Rightarrow Transverse cooling.

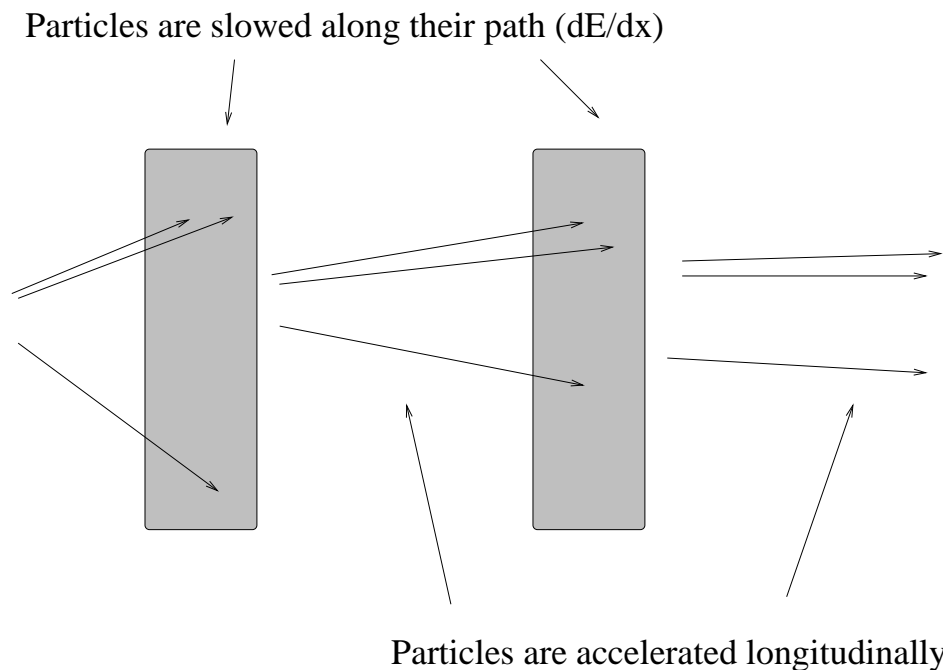

- Multiple scattering ‘heats’ the beam.
- If no heating, ‘stop’ the beam once, and reaccelerate.
- In practice, ‘stop’ the beam ≈ 10 times, \Rightarrow 6-GeV acceleration.

Ionization Cooling Theory

Transverse cooling by ionization, heating by multiple scattering:

$$\frac{d\epsilon_n}{ds} = -\frac{1}{\beta^2} \frac{dE_\mu}{ds} \frac{\epsilon_n}{E_\mu} + \frac{\beta_\perp (0.014)^2}{2\beta^3 E_\mu m_\mu L_R},$$

$$\epsilon_n = \sigma_x \sigma_{P_x} / m_\mu c,$$

β_\perp = Betatron function at the absorber,

L_R = Radiation length of absorber.

$$\Rightarrow \text{Equilibrium } \epsilon_n \propto \frac{\beta_\perp}{\beta L_R (dE_\mu/ds)}.$$

\Rightarrow Low- Z absorber (liquid hydrogen is best),

\Rightarrow Put absorber at low- β_\perp (beam-waist),

\Rightarrow Need strong focusing (15-T solenoids, Li lens...),

\Rightarrow Keep $\beta = v/c$ near 1.

[Economics favor $\beta < 1$ since must restore the beam energy many times,]

But the **energy spread rises**:

$$\frac{d(\Delta E_\mu)^2}{ds} = -2 \frac{d\left(\frac{dE_\mu}{ds}\right)}{dE_\mu} (\Delta E_\mu)^2 + \frac{d(\Delta E_\mu)_{\text{straggling}}^2}{ds}.$$

Both terms are positive if operate below minimum of dE_μ/ds curve.

⇒ Must exchange longitudinal and transverse emittance frequently to avoid beam loss due to bunch spreading.

Can reduce energy spread by a wedge absorber at a momentum dispersion point:

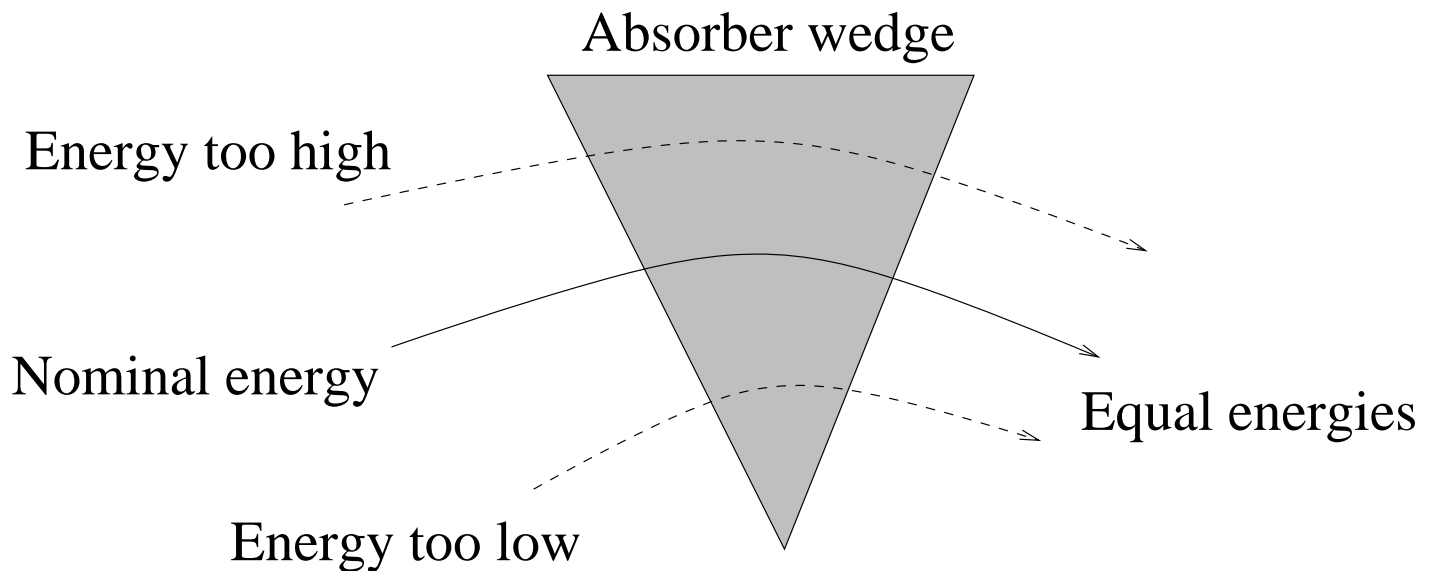

[6-D emittance constant (at best) in this process.]

Emittance Exchange Via Wedges + Bent Solenoids

LONGITUDINAL COOLING

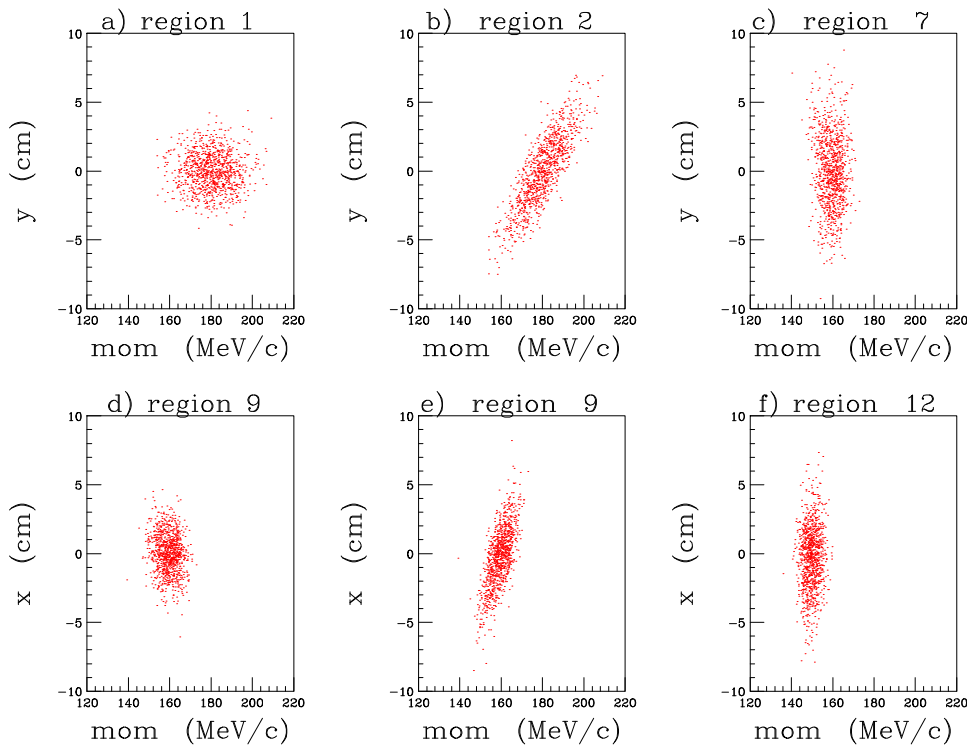
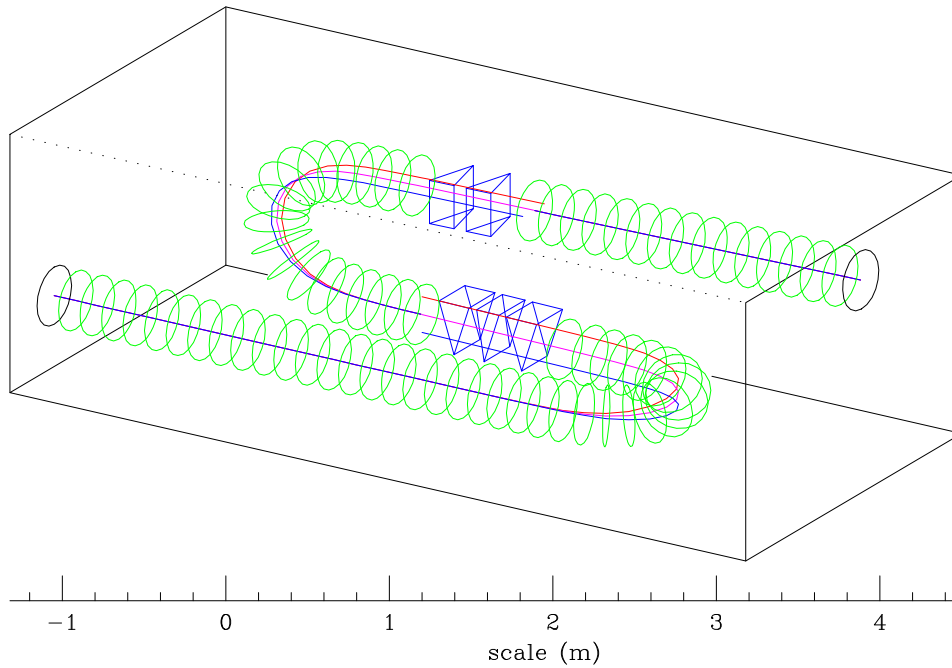

Ionization Cooling of ν -Produced μ 's

The muon toroids of the CCFR neutrino experiment form an ionization-cooling channel

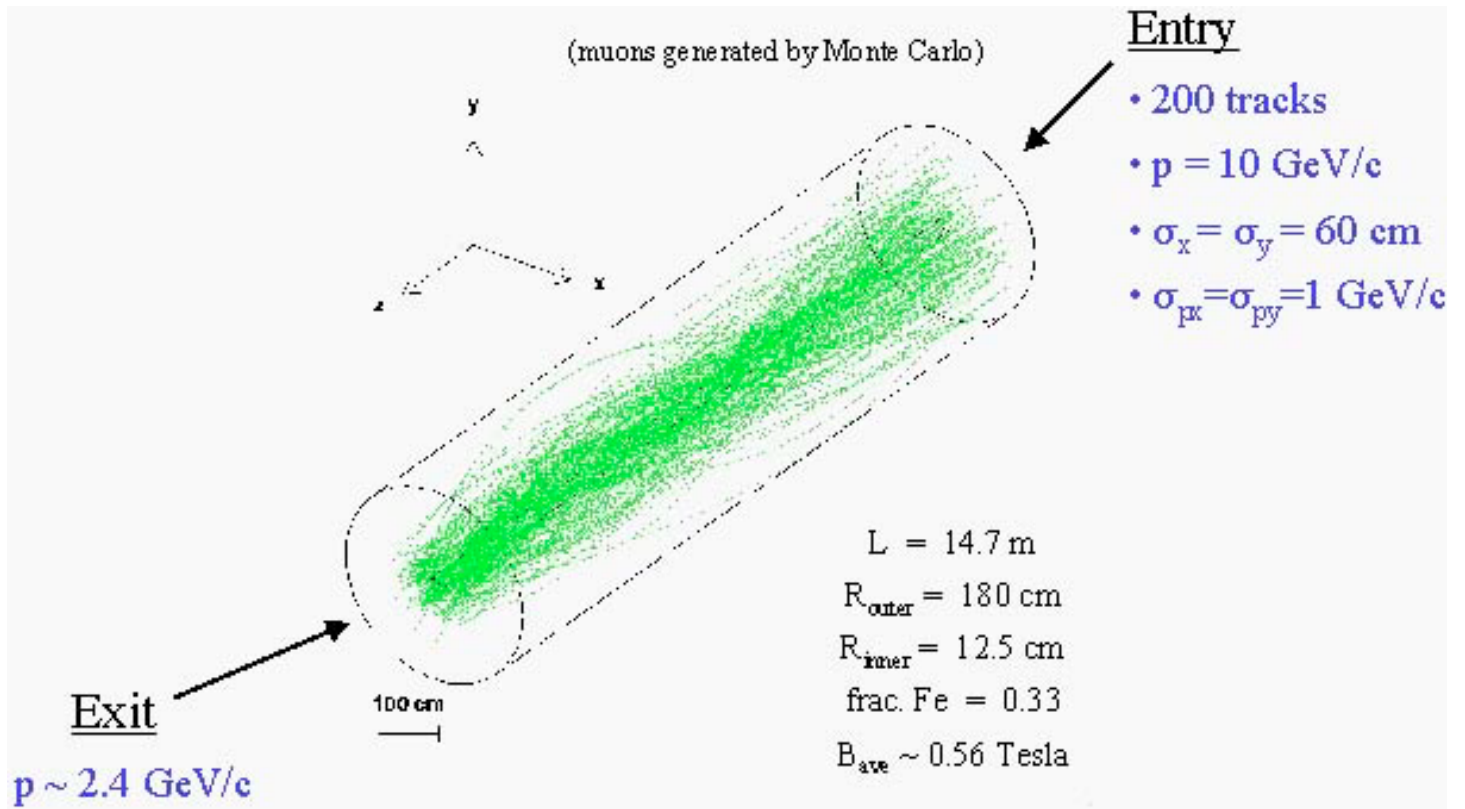

Simulation indicates $\epsilon_n \rightarrow \epsilon_n/4$.

Data analysis underway [Bruce King].

Cooling in a Channel of Alternating Solenoids

Must alternate direction of \mathbf{B} to avoid buildup of canonical angular momentum.

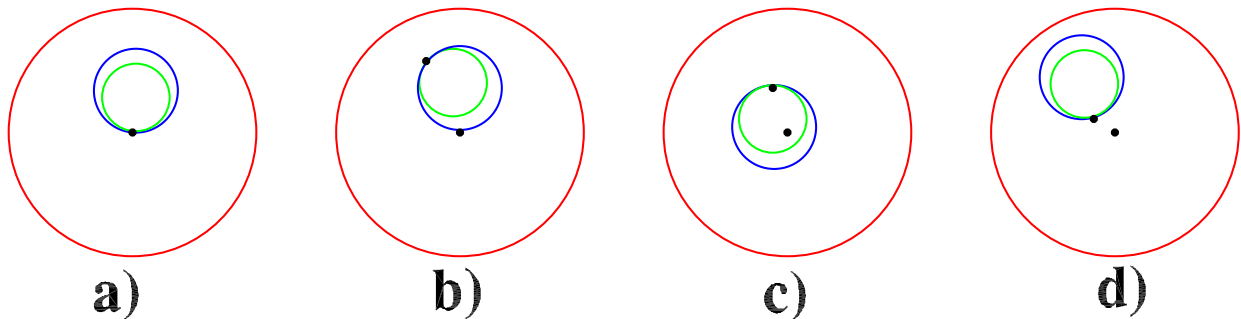
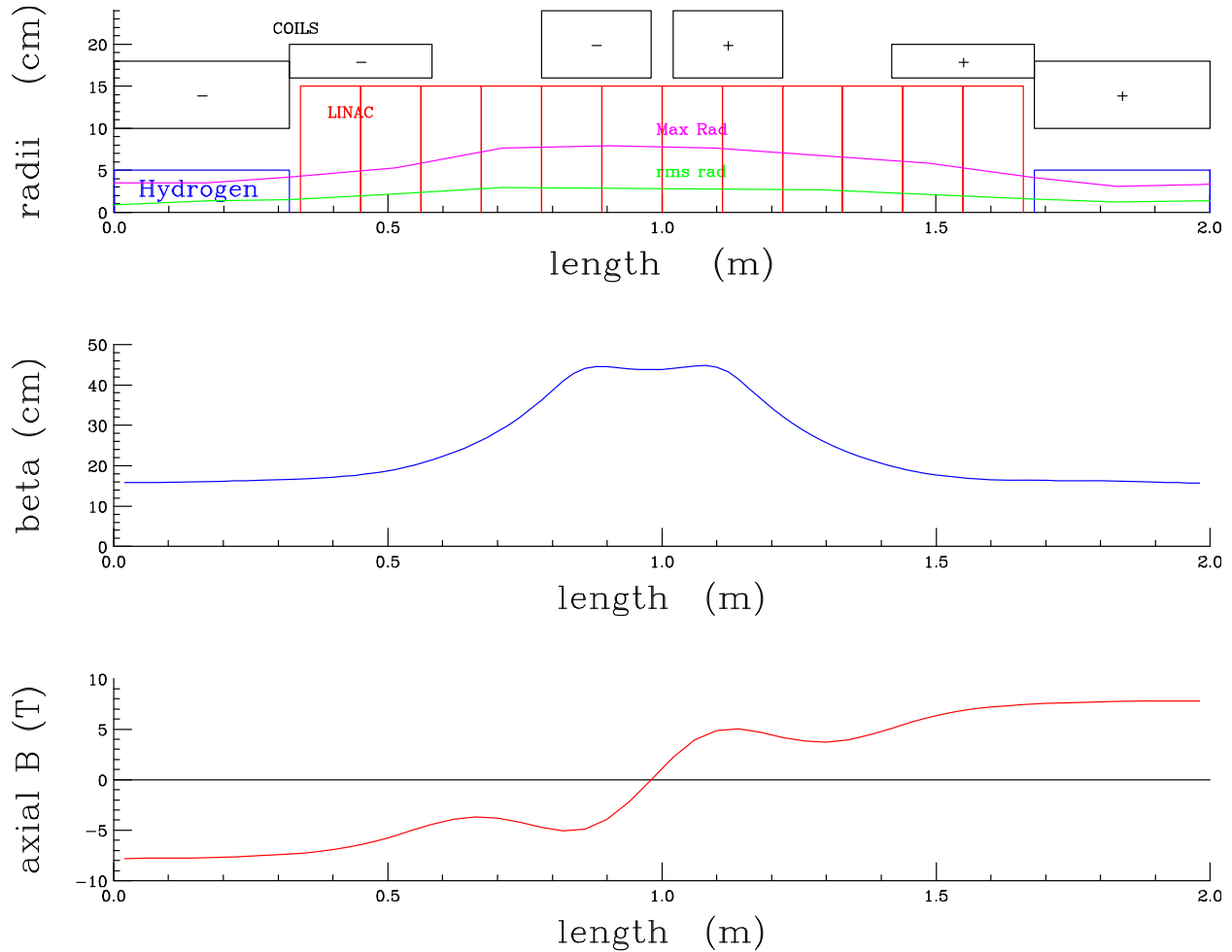

A cooling **section** contains 10 2-m-long **cells** as above:

- 64 cm of LH₂ around the low- β_{\perp} point inside a 15-T solenoid,
- 4 lower-field solenoids to flip sign of magnetic field.
- 12 $\pi/2$ mode **rf cavities**, 800-MHz, 5-mil Be windows, 30 MV/m gradient.

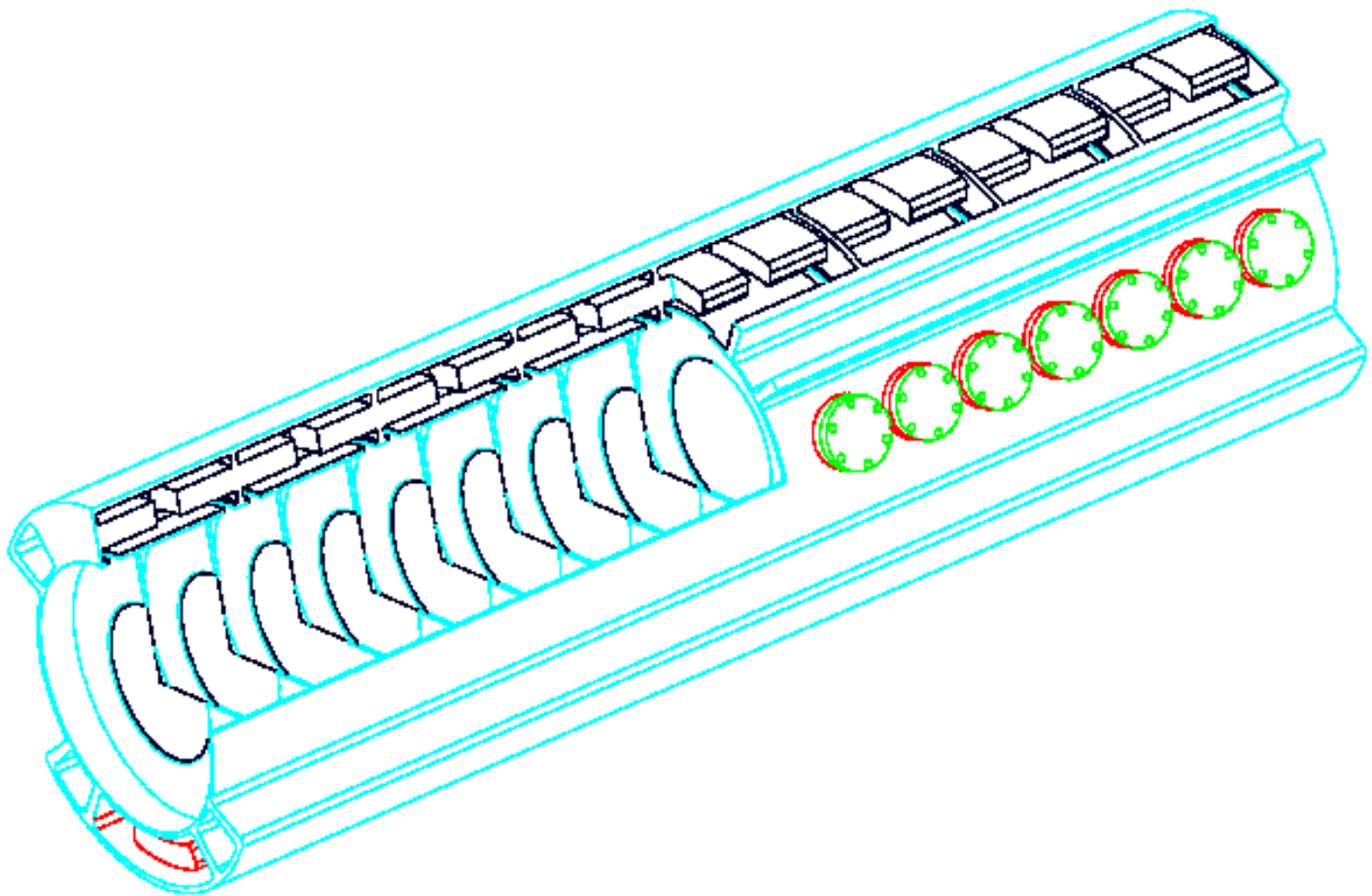

Interleaved side coupled, standing-wave structure.

[Al Moretti]

Simulated Cooling Performance

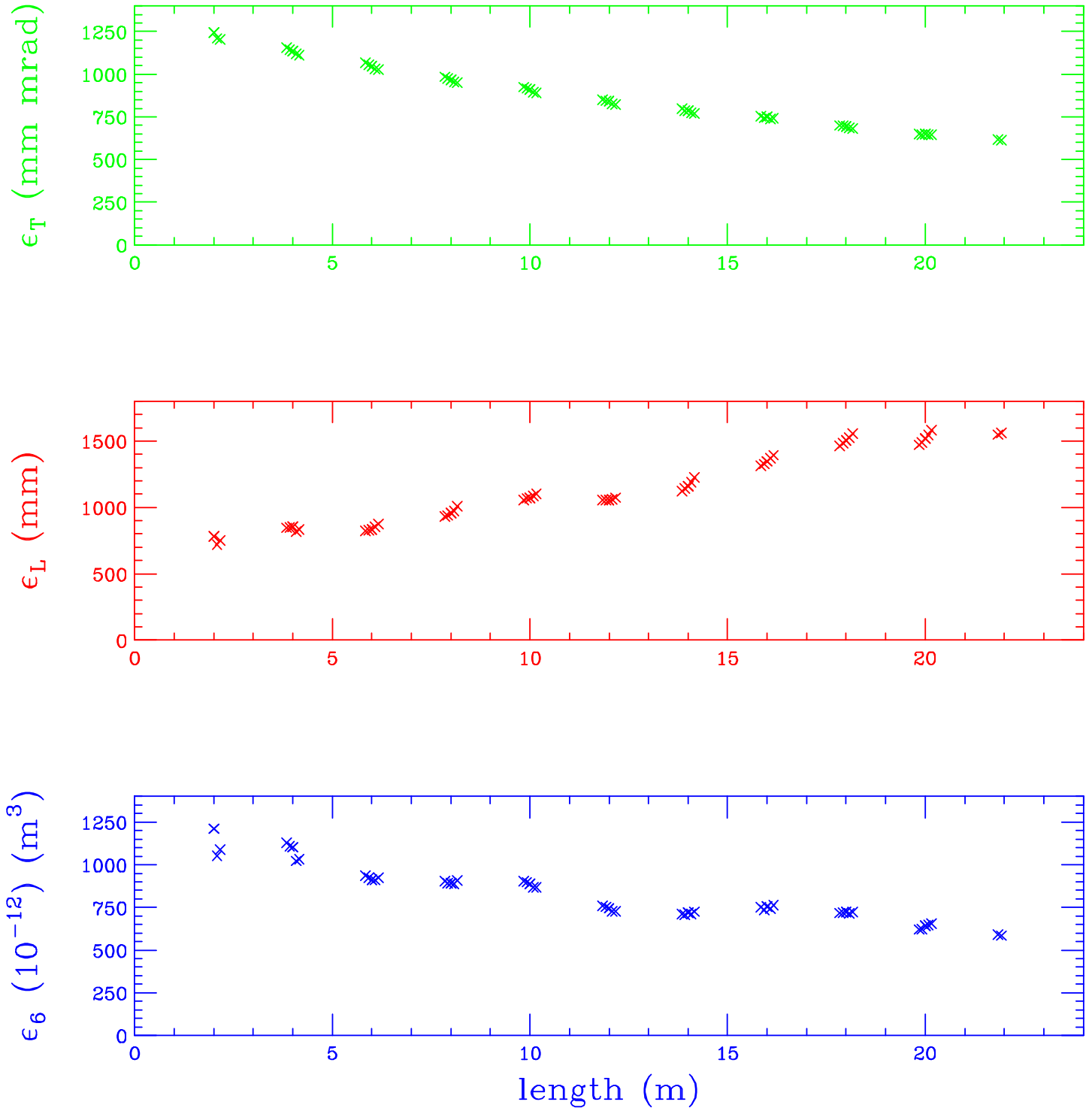

Factor of 2 reduction in 6-d emittance in a 20-m stage.

Simulated Cooling Performance

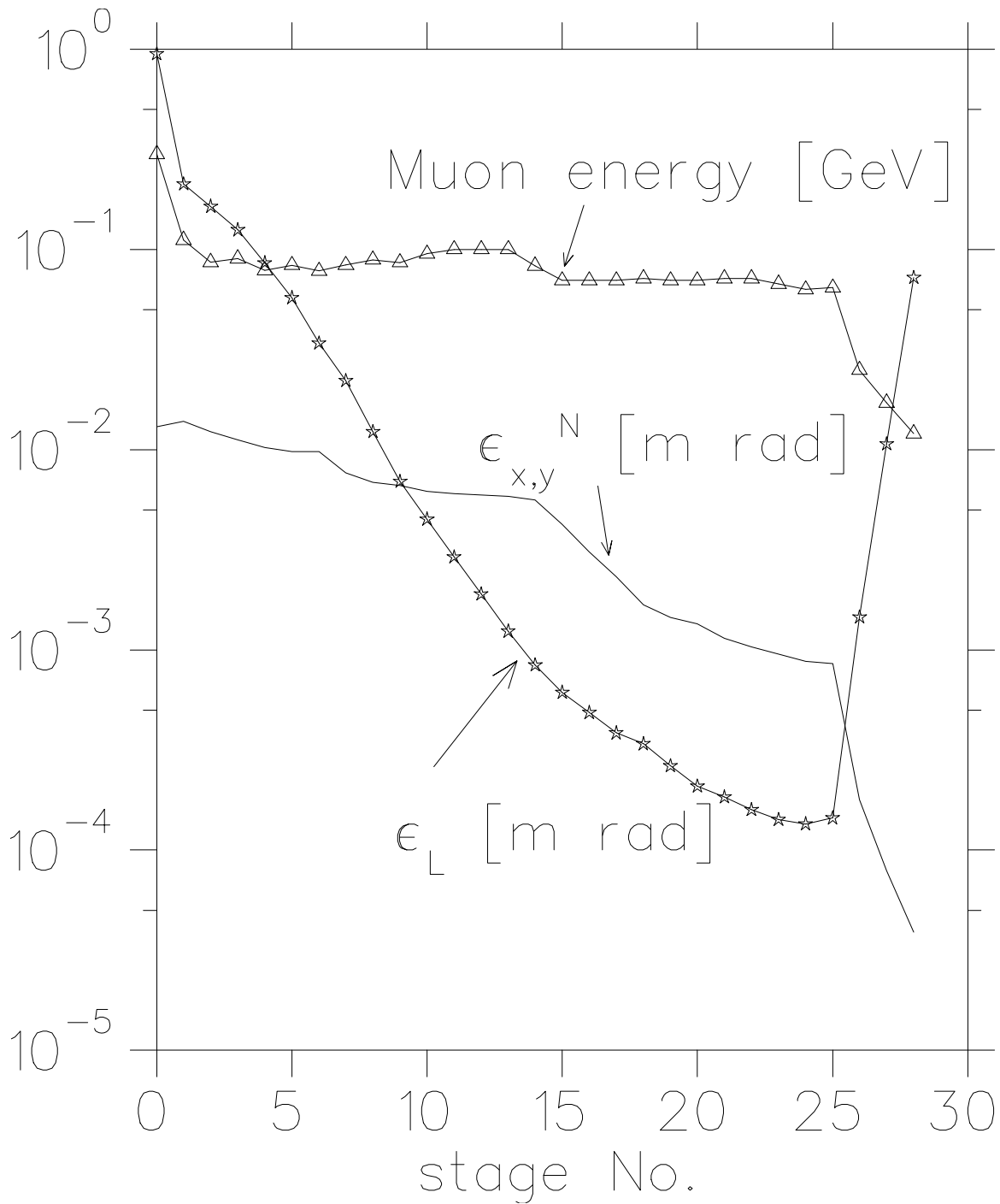

Alternating-solenoid scheme becomes difficult after ≈ 25 stages.

But more cooling is desirable.

Cooling in Lithium Lenses

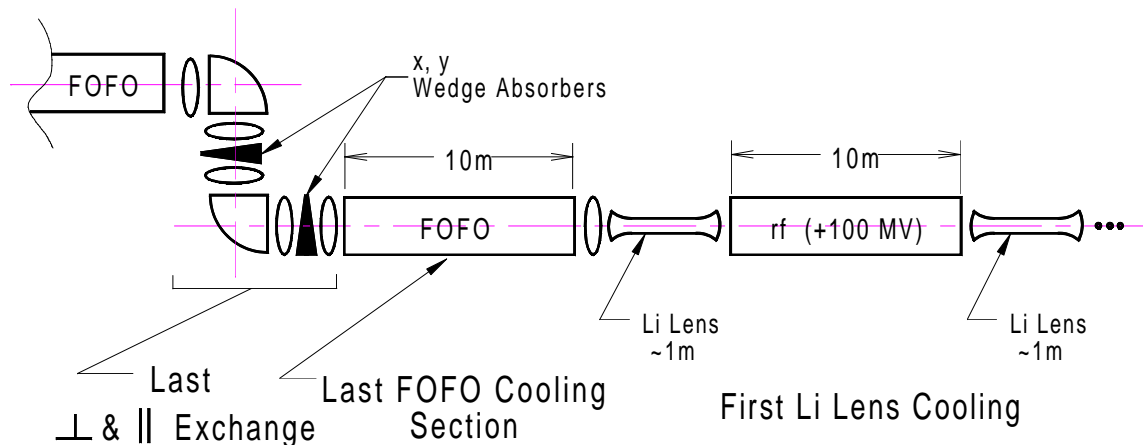

LITHIUM CURRENT CARRYING COOLING ROD

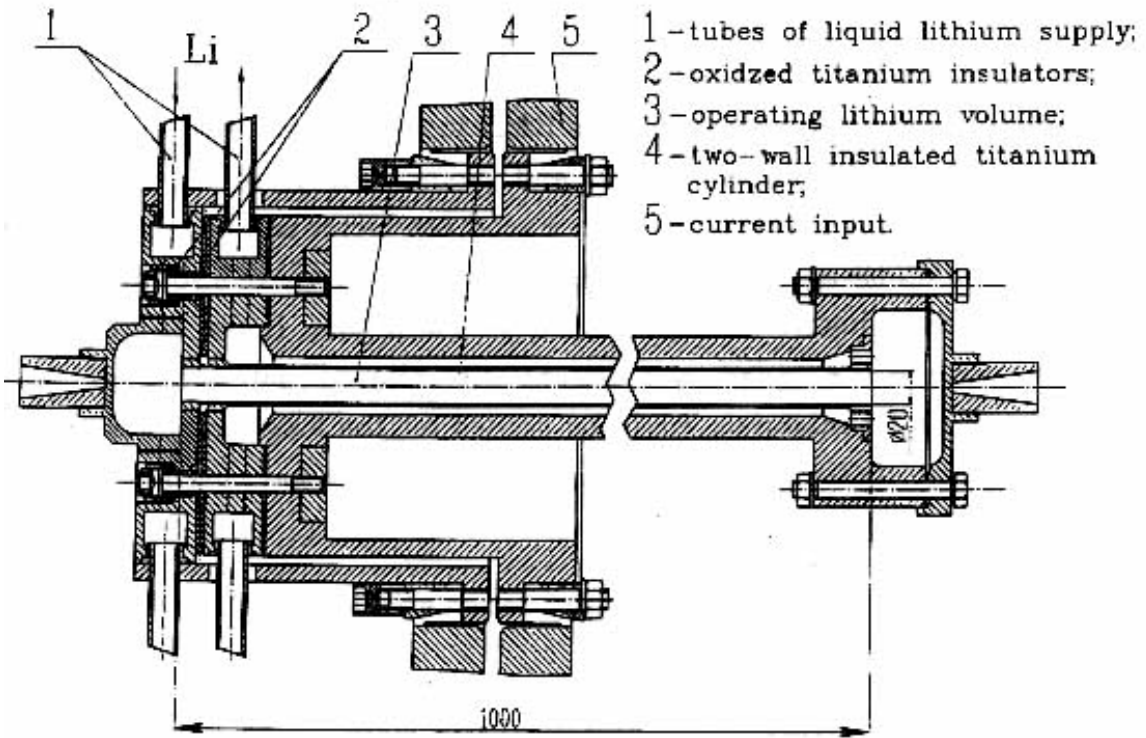

Simulation of Cooling in Lithium Lenses

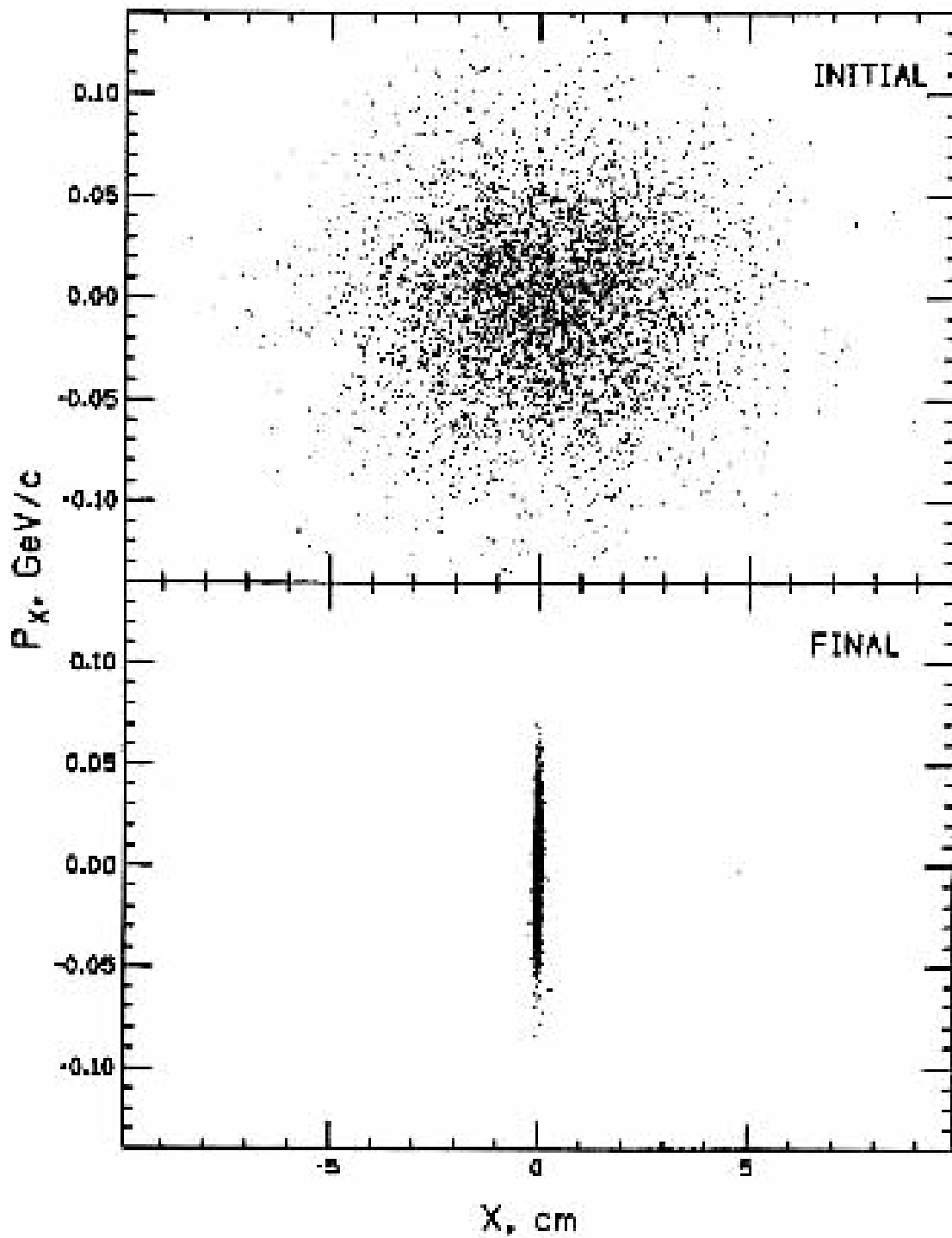

Even lower emittance 'possible' with optical stochastic cooling.

The Muon Collider Collaboration

Charles M. Ankenbrandt¹, Giorgio Apollinari², Muzaffer Atac¹, Bruno Autin³,
Valerie I. Balbekov¹, Vernon D. Barger⁴, Odette Benary⁵, Michael S. Berger⁶,
S. Alex Bogacz⁷, T. Bolton⁸, Shlomo Caspi⁹, Christine Celata⁹, Yong-Chul Chae¹⁰,
David B. Cline¹¹, John Corlett⁹, H. Thomas Diehl¹, Alexandr Drozhdin¹,
Richard C. Fernow¹², Yasuo Fukui¹, Miguel A. Furman⁹, Juan C. Gallardo^{12,1},
Alper A. Garren¹¹, Stephen H. Geer¹, Ilya F. Ginzburg¹³, Michael A. Green⁹,
John F. Gunion¹⁴, Ramesh Gupta⁹, Tao Han¹⁴, Katherine C. Harkay¹⁰, Colin Johnson³,
Carol Johnstone¹, Stephen A. Kahn¹², Bruce J. King¹², Harold G. Kirk¹²,
Masayuki Kumada¹⁵, Paul LeBrun¹, Kevin Lee¹¹, Derun Li⁹, David Lissauer¹²,
Laurence S. Littenberg¹², Changguo Lu¹⁶, Alfredo Luccio¹², Kirk T. McDonald¹⁶,
Alfred D. McInturff⁹, Frederick E. Mills¹, Nikolai Mokhov¹, Alfred Moretti¹,
David V. Neuffer¹, King-Yuen Ng¹, Robert J. Noble¹, James H. Norem^{10,1},
Blaine E. Norum¹⁷, Hiromi Okamoto¹⁸, Yasar Onel¹⁹, Robert B. Palmer¹²,
Zohreh Parsa¹², Jack M. Peterson⁹, Yuriy Pischalnikov¹¹, Milorad Popovic¹,
Eric J. Prebys¹⁶, Zubao Qian¹, Rajendran Raja¹, Pavel Rehak¹², Thomas Roser¹²,
Robert Rossmann²⁰, Jack Sandweiss²¹, Ronald M. Scanlan⁹, Lindsay Schachinger⁹,
Andrew M. Sessler⁹, Quan-Sheng Shu⁷, Gregory I. Silvestrov²², Alexandr N. Skrinsky²²,
Ray Stefanski¹, Sergei Striganov¹, Iuliu Stumer¹², Don Summers²³, Valery Tayursky²²,

Valeri Tcherniatine¹², Lee C. Teng¹⁰, Alvin V. Tollestrup¹, Yāğmur Torun¹²,
Dejan Trbojevic¹², William C. Turner⁹, Andy Van Ginneken¹,
Tatiana A. Vsevolozhskaya²², Masayoshi Wake²⁴, Wishi Wan¹, Robert Weggel¹²,
Erich H. Willen¹², David R. Winn²⁵, Jonathan S. Wurtele²⁶, Yongxiang Zhao¹²,
Max Zolotarev⁹

¹Fermi National Laboratory, P. O. Box 500, Batavia, IL 60510

²Rockefeller University, New York, NY 10021

³CERN, 1211 Geneva 23 Switzerland

⁴Department of Physics, University of Wisconsin, Madison, WI 53706

⁵Tel-Aviv University, Ramat-Aviv, Tel-Aviv 69978, Israel

⁶Physics Department, Indiana University, Bloomington, IN 47405

⁷Jefferson Laboratory, 12000 Jefferson Ave., Newport News, VA 23606

⁸Kansas State University, Manhattan, KS 66502-2601

⁹Lawrence Berkeley National Laboratory, 1 Cyclotron Rd., Berkeley, CA 94720

¹⁰Argonne National Laboratory, Argonne, IL 60439

¹¹Univ. of California Los Angeles, Los Angeles, CA 900095

¹²Brookhaven National Laboratory, Upton, NY 11973

¹³Institute of Mathematics, Prosp. ac. Koptiyug 4, 630090 Novosibirsk, Russia

¹⁴Physics Department, University of California, Davis, CA 95616

¹⁵National Institute of Radiological Sciences, 4-9-1 Anagawa, Inage, Chiba, Japan

¹⁶Joseph Henry Laboratories, Princeton University, Princeton, NJ 08544

¹⁷University of Virginia, 205 McCormick Road, Charlottesville, VA 22901

¹⁸N.S.R.F, Institute for Chemical Research, Kyoto University, Gokanoshou, Uji, Kyoto
611, Japan

¹⁹Physics Department, Van Allen Hall, University of Iowa, Iowa City, IA 52242

²⁰DESY, Hamburg, Germany

²¹Physics Department, Yale University, CT 06520

²² Budker Institute of Nuclear Physics, 630090 Novosibirsk, Russia

²³University of Mississippi, Oxford, MS 38677

²⁴KEK High Energy Accelerator Research Organization, 1-1 Oho, Tsukuba, 305 Japan

²⁵Fairfield University, Fairfield, CT 06430

²⁶University of California Berkeley, Berkeley, CA 94720

Collaboration Organization

Spokesperson: Bob Palmer (BNL)

Associate Spokesmen: Alvin Tollestrup (FNAL), Andy Sessler (LBNL)

Executive Committee: Bob Palmer, Juan Gallardo (BNL),
Steve Geer, Alvin Tollestrup (FNAL),
Andy Sessler, Jonathan Wurtele (LBNL)
Dave Cline (UCLA), Kirk McDonald (Princeton),
Sasha Skrinksky (BINP), Don Summers (U. Miss)

Technical Committee: Bob Palmer, Rick Fernow (BNL),
Bob Noble (FNAL), Ron Scanlan (LBNL)

Theoretical R&D: Organizer: J. Wurtele

Cooling Experiment: Spokesman: Steve Geer (FNAL),
Coordinators: Rick Fernow (BNL), Bill Turner (LBNL)

Target and Capture Experiment: Spokesmen:

Kirk McDonald (Princeton), Bob Weggel (BNL)

Pulsed Accelerator Magnet: Organizer:

Don Summers (U. Miss.)

Superconducting Accelerator Magnet: Organizer:

R. Scanlan (LBNL)

BNL E-910 (Pion Production): Spokesman: Harold Kirk (BNL)

FNAL E-932 (Proton Compression): Spokesman:

Jim Norem (ANL)

R&D Priorities

- Theoretical Studies:
 - Cooling scenarios (now working ‘on paper’!)
 - 4-TeV Collider
 - ‘Demonstration’ Machines
 - * \approx 100-GeV Higgs Factory
 - * 200- and 400-GeV Upgrades
- Experimental Programs:
 - Prototype Superconducting Accelerator Magnets and RF Cavities
 - Cooling Demonstration
 - Target and RF Capture Demonstration
 - Prototype Pulsed Ring Magnets

Cooling Demonstration Experiment

Test basic cooling components:

- Alternating solenoid lattice, RF cavities, LH₂ absorber
- Lithium lens (for final cooling)
- Dispersion + wedge absorbers to exchange longitudinal and transverse phase space

Phase I: Track individual muons; simulate a bunch in software

Phase II: Cool a muon bunch from prototype source

Cooling Demonstration Experiment

Possible site: Meson Lab at Fermilab:

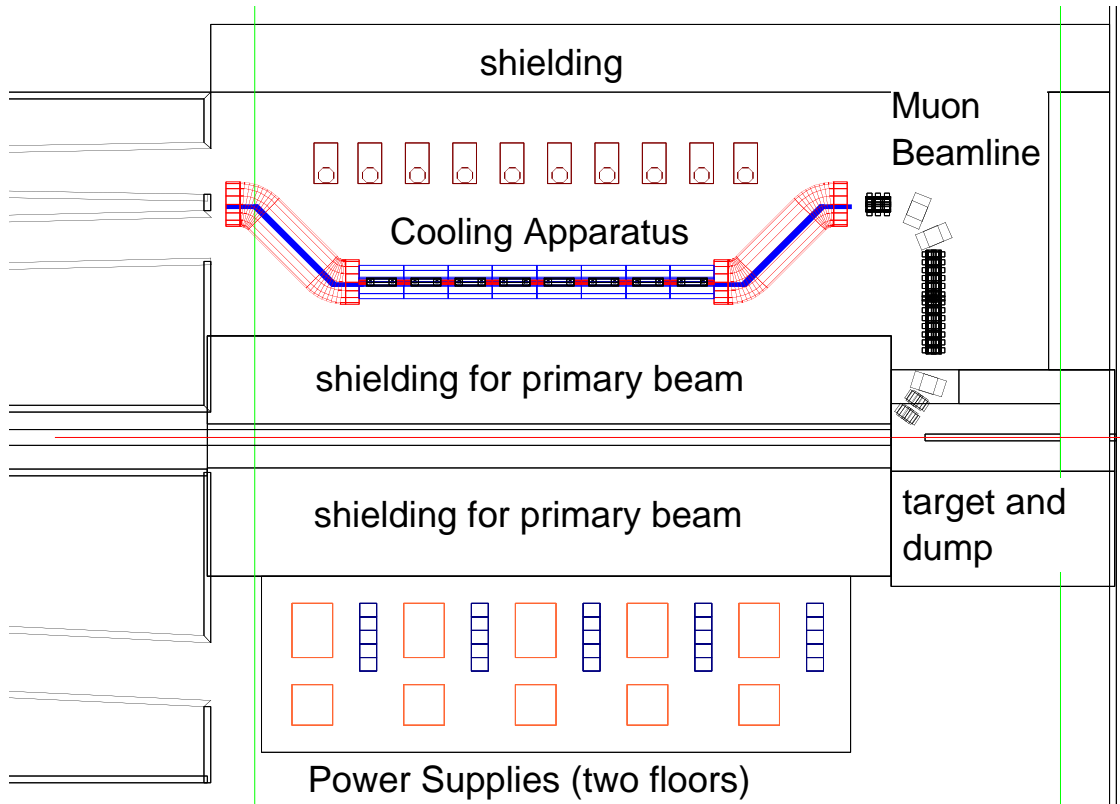

Measure 6-D emittance before and after cooling:

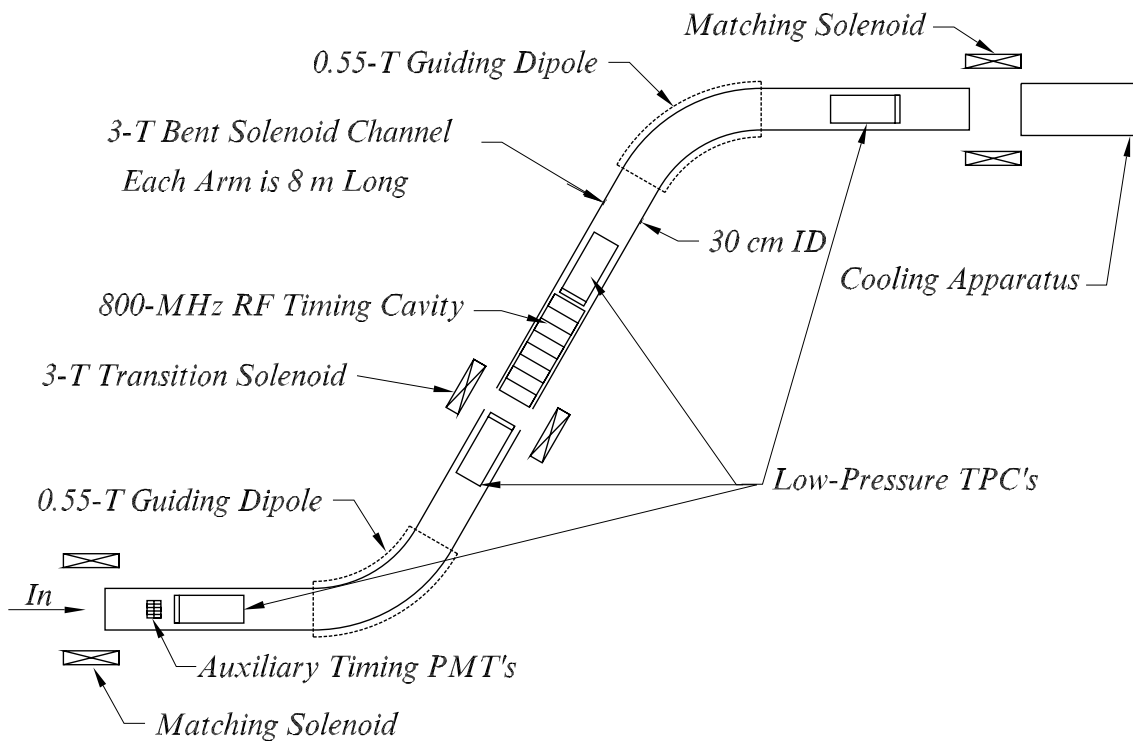

HEPAP Subpanel Report on PLANNING FOR THE FUTURE OF U.S. HIGH-ENERGY PHYSICS

February 1998

Recommendation on R&D for a Muon Collider

The Subpanel recommends that an expanded program of R&D be carried out on a muon collider, involving both simulation and experiments. This R&D program should have central project management, involve both laboratory and university groups, and have the aim of resolving the question of whether this machine is feasible to build and operate for exploring the high-energy frontier. The scale and progress of this R&D program should be subject to additional review in about two years.

CERN-EP/98-03
CERN-SL 98-004 (AP)
CERN-TH/98-33

Options for Future Colliders at CERN

J. Ellis, E. Keil, G. Rolandi

January 23, 1998

6 RECOMMENDATIONS

3. CERN should launch technical studies of $\mu^+\mu^-$ colliders, notably in the areas of the source and beam cooling, and should explore the possibility of locating such machines on or in the neighbourhood of the CERN site.
6. These studies should be carried out in collaborations with other laboratories, since most technical problems do not depend on the site. CERN's goal in these collaborations should be to contribute to the global pool of technologies for future collider options. It should confirm its reputation as a valuable and reliable partner in the international collaborations that will form to develop proposals for future collider projects.