



**Argonne**  
NATIONAL  
LABORATORY

*... for a brighter future*

# ***Lead-Bismuth Spallation Target Design***

***Yousry Gohar***

***Nuclear Engineering Division  
Argonne National Laboratory  
9700 S. Cass Avenue,  
Argonne, IL 60439, USA***

***Applications of High Intensity Proton  
Accelerators Workshop***

***Fermi National Accelerator Laboratory,  
Batavia, IL 60510, USA  
October 19-21, 2009***



U.S. Department  
of Energy



A U.S. Department of Energy laboratory  
managed by The University of Chicago

# Accelerator Driven System (100 MW<sub>t</sub>, 5 MW Beam, 600MeV Protons)

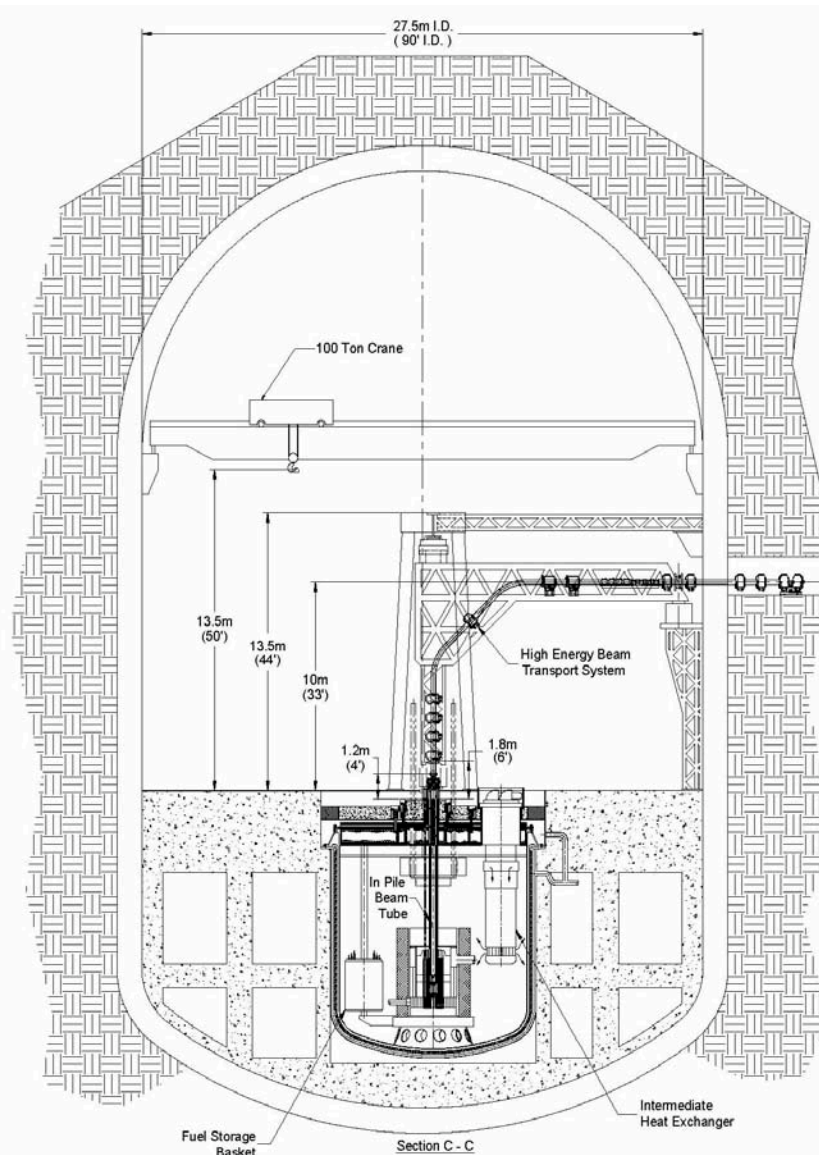

# Target and Core Configuration of Accelerator Driven System

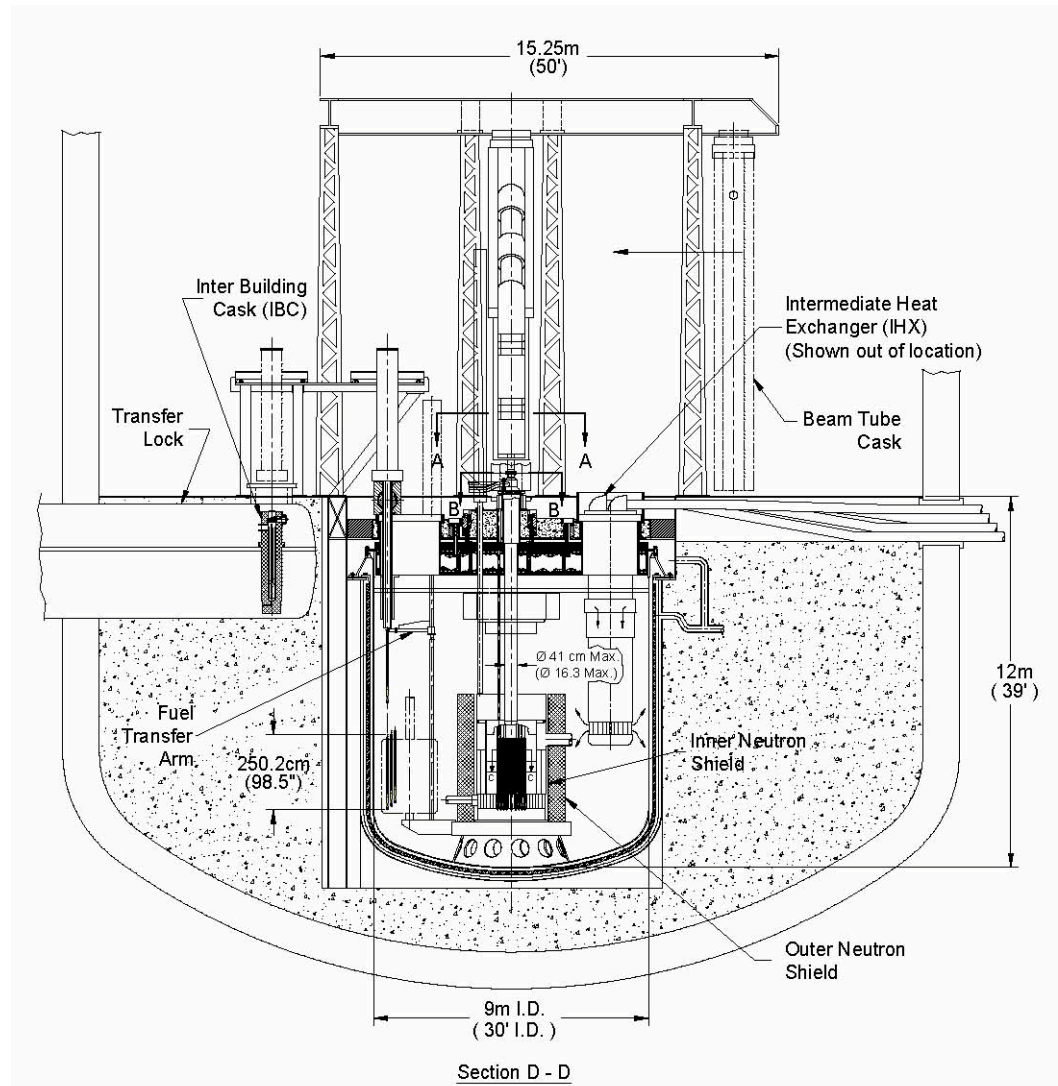
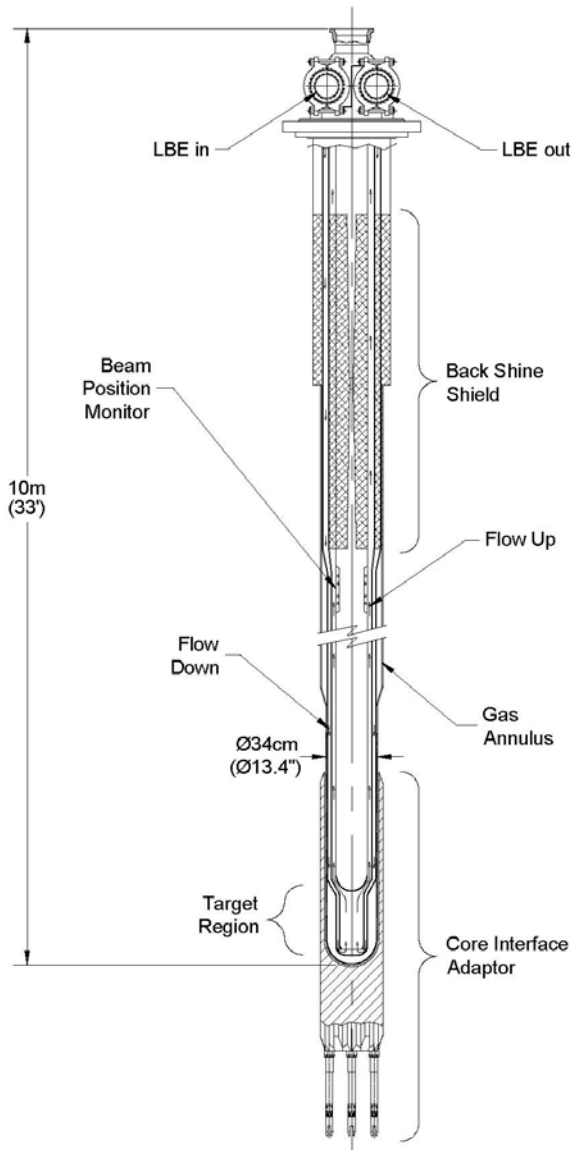

# ***Lead-Bismuth Spallation Target Design***

A study was carried out to analyze and design a Lead-Bismuth spallation target for driving a subcritical assembly.

## **Performance Parameters:**

- **Produce the required neutron source with the appropriate spatial distribution to operate the subcritical multiplier.**
- **Protect the subcritical multiplier from the high-energy protons and neutrons.**
- **Contain the spallation products during normal and abnormal conditions.**
- **Achieve a long lifetime to satisfy the plant availability goal.**
- **Utilize a simple and fast replacement procedure for normal and abnormal conditions.**
- **Operate and fail safely to achieve the required plant performance.**

# ***Lead-Bismuth Spallation Target Design***

## **Design Constraints:**

- Utilize existing structural materials and engineering databases as much as possible.
- The coolant operating conditions are constrained to satisfy different engineering requirements.
- The coolant chemistry is closely controlled to reduce corrosion concerns.
- The structure temperature is constrained to insure satisfactory mechanical properties.
- The target diameter is minimized to maximize the utilization of the spallation neutrons, to simplify the target replacement procedures, to reduce the neutron losses in the beam direction, to decrease the shield volume, and to reduce the required number of the subcritical multiplier fuel assemblies.
- The target decay heat is removed by radiation, natural convection, and conduction to the shielding materials.

# ***Lead-Bismuth Spallation Target Design Analyses***

**Several parametric studies and design iterations were performed to develop the current LBE target design including:**

- Physics analyses**
- Thermal hydraulic analyses**
- Structural analyses including radiation effects**
- Radiological analyses**
- Safety analyses**
- Target interface**
- Mechanical design**
- Maintenance procedure**
- Leak detection procedure**

# Spatial Energy Deposition in the Lead-bismuth Eutectic for Different Proton Energies with a Uniform Proton Beam Distribution

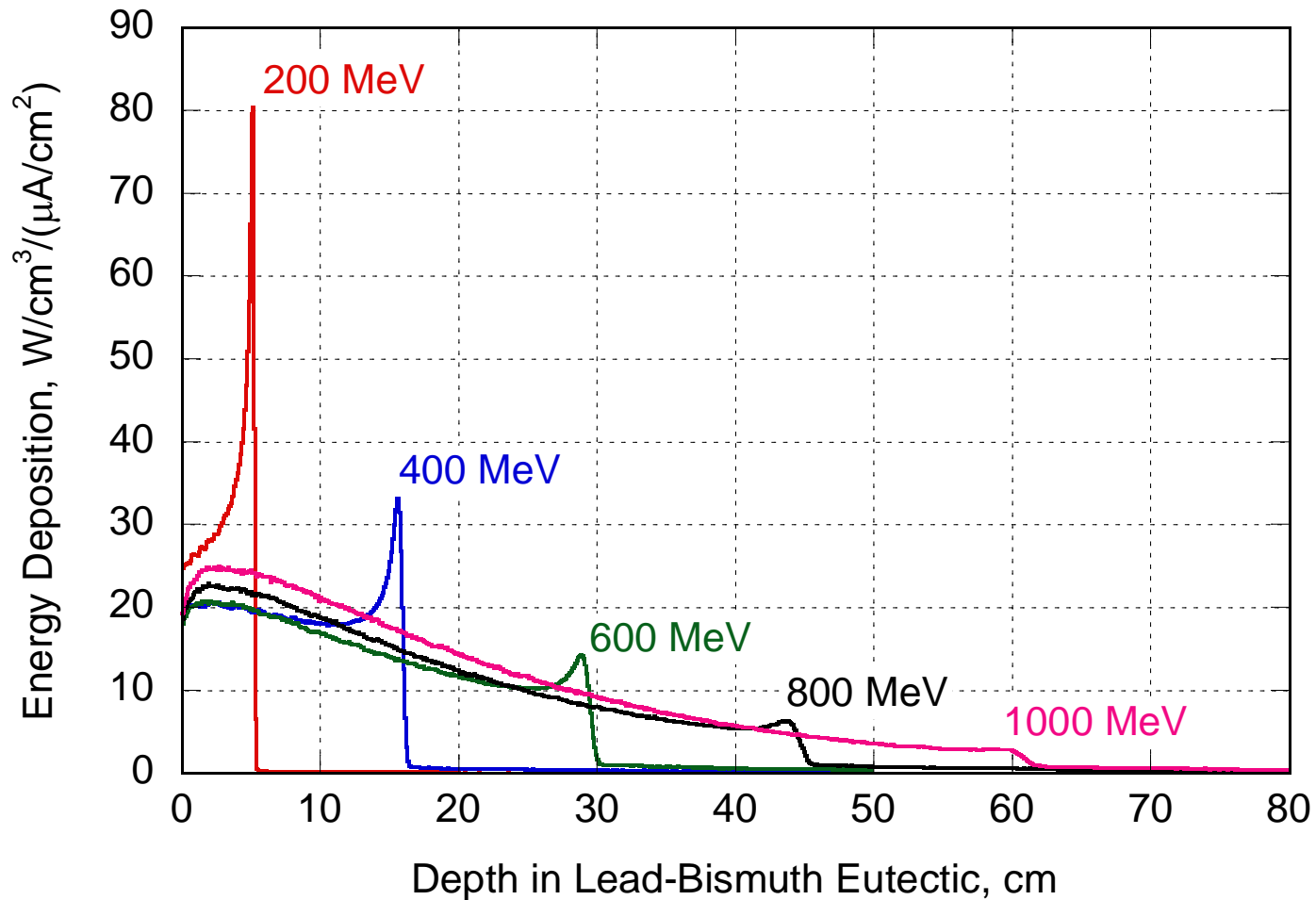

# Number of Neutrons per Proton and Neutron Percentage with Energy above 20 MeV as a Function of the Proton Energy from the Lead-bismuth Eutectic

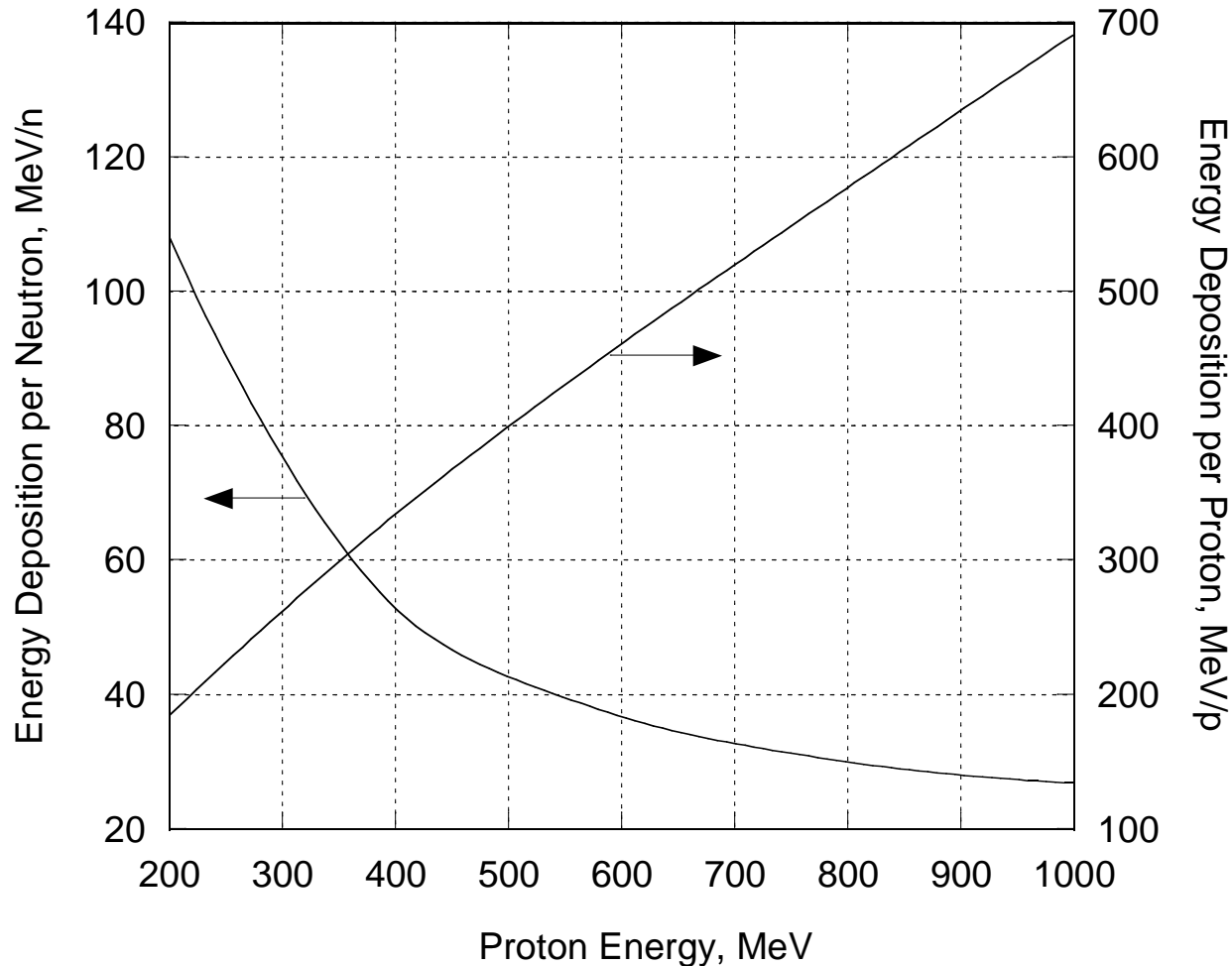



# *Energy Deposition in the Lead-bismuth Eutectic as a Function of the Proton Energy Normalized per Incident Proton on the Right Axis and per Generated Neutron on the Left Axis*

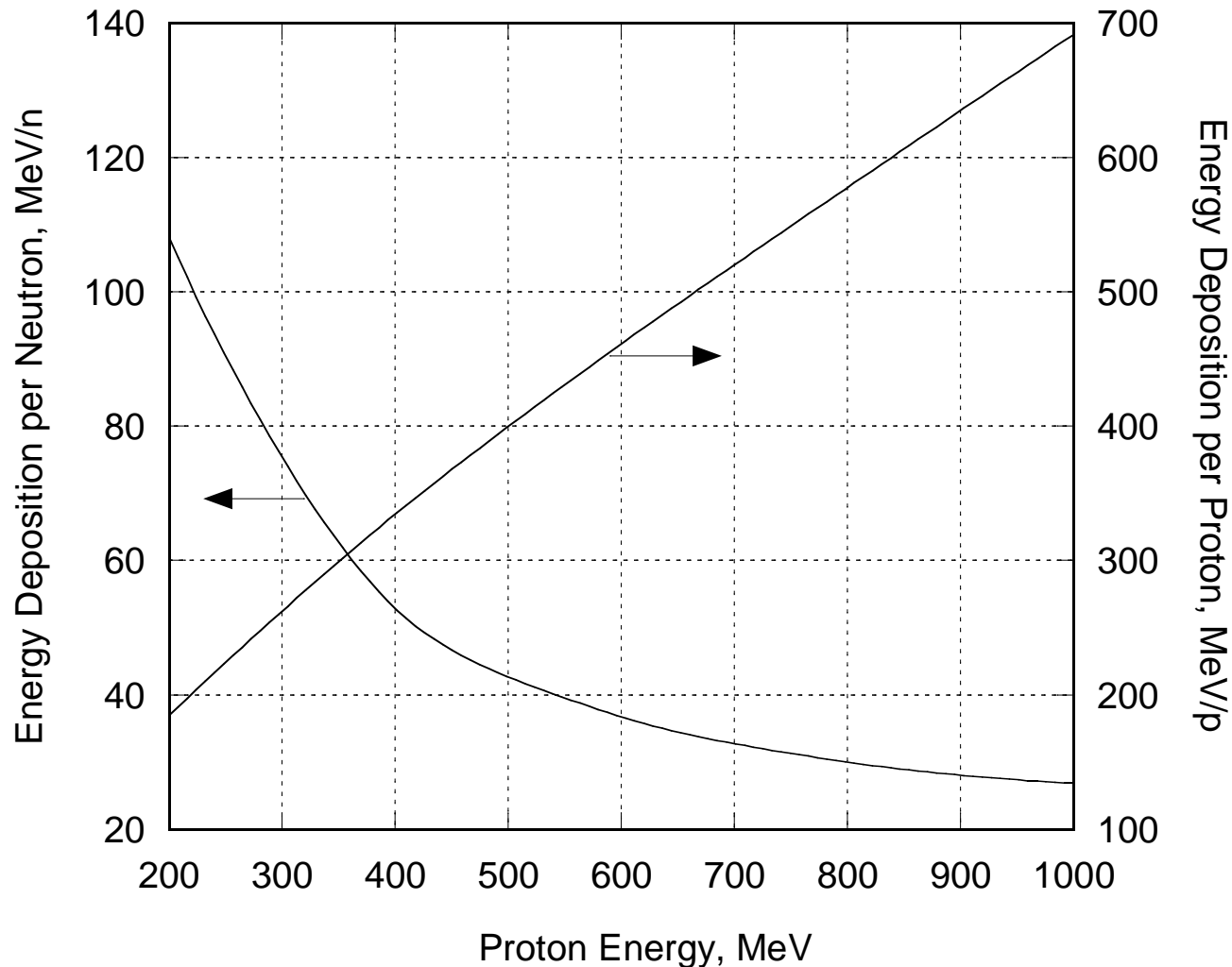

# Generated Neutron Spectra for Different Proton Energies Normalized per Generated Neutron from the Lead-bismuth Eutectic

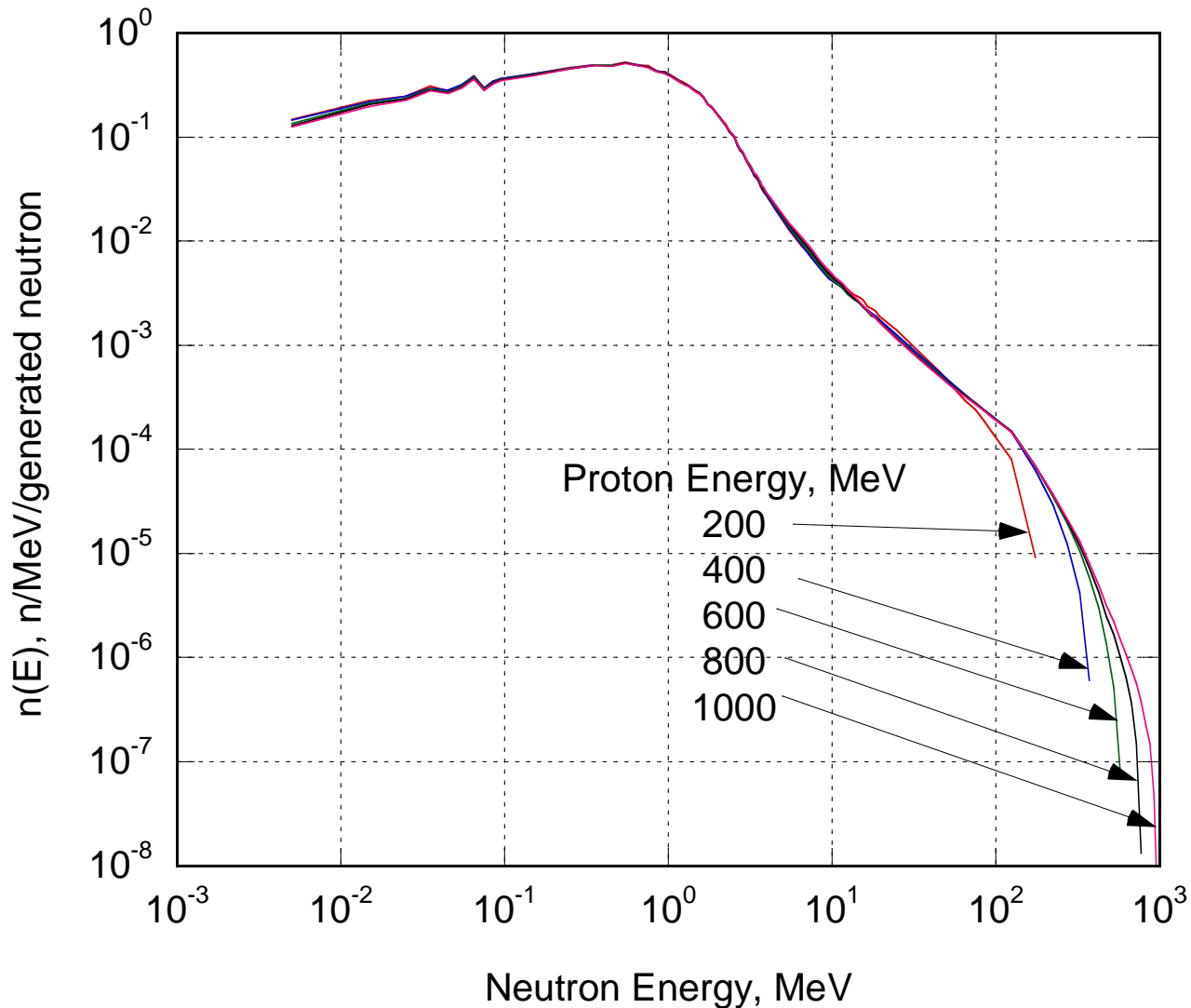

# Comparison of the Lead-bismuth Neutron Spectrum Generated by Proton and the Fission Neutron Spectrum Normalized per Generated Neutron

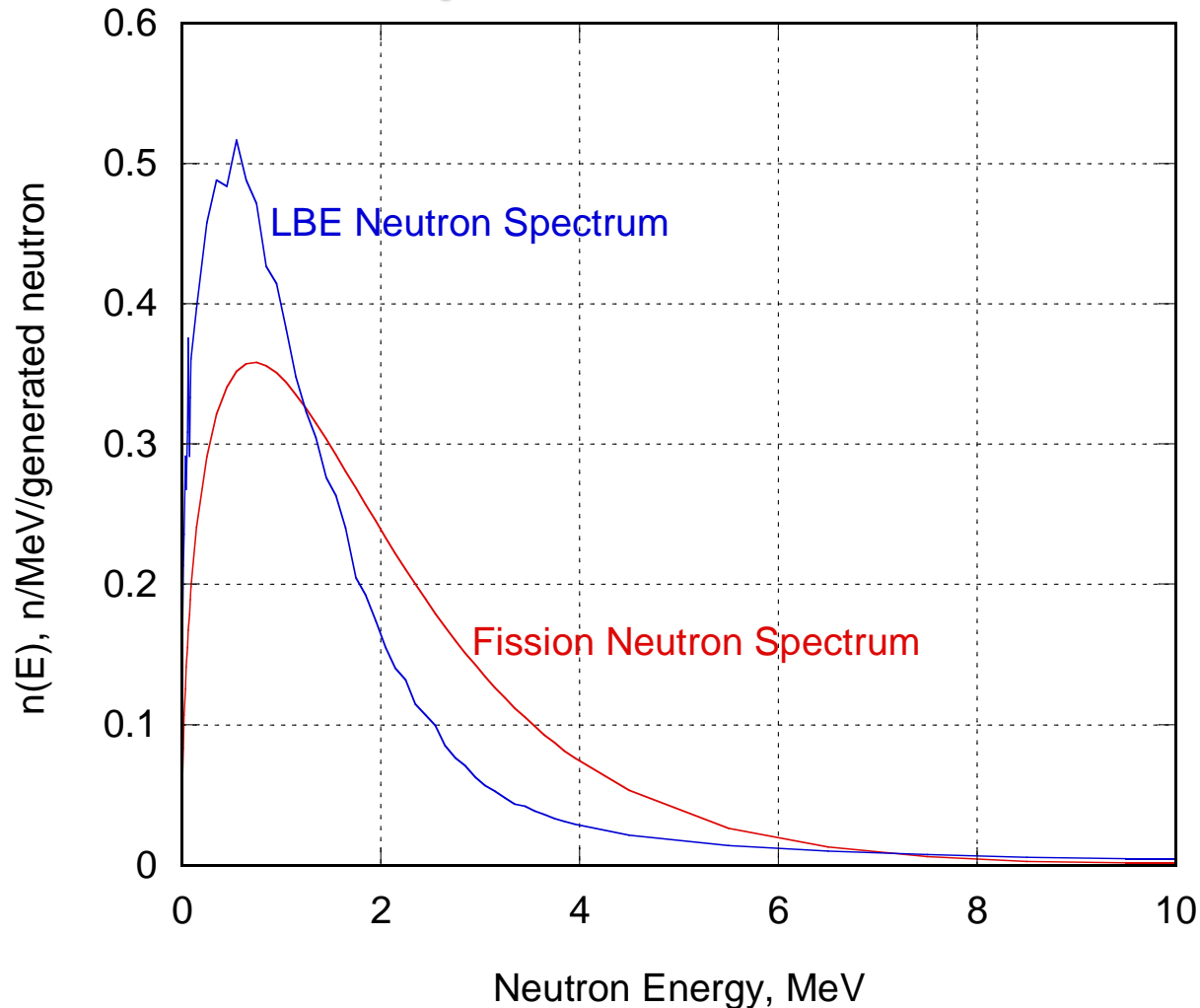

# Number of Generated Neutrons per Proton as a Function of the Buffer Thickness From the Lead-bismuth Eutectic Target for Different Proton Energies

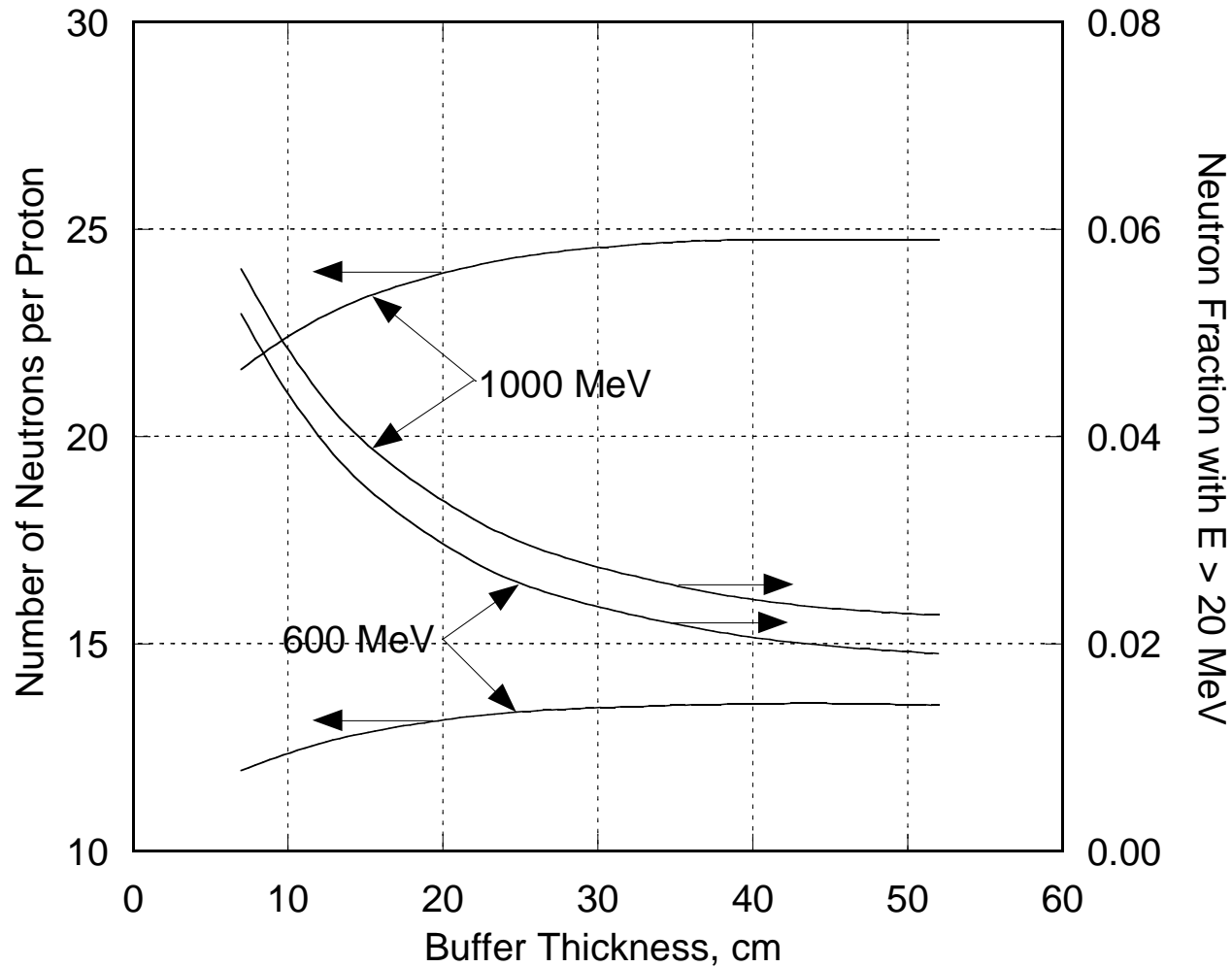

# ***Target Design Example for 5 MW 600 MeV Proton Beam***

## **Proton Beam**

Power	5 MW
Current	8.33 mA
Proton Energy	600 MeV
Current Distribution	Uniform
Current Density	40 $\mu\text{A}/\text{cm}^2$

## **Engineering Parameters**

Steel Structural Material	HT9 or 316SS
Maximum Average Lead-Bismuth Velocity	2 m/s
Maximum Steel Surface Temperature	550 C
Maximum Steel Temperature	
HT9 Steel	550 C
Type 316 Stainless Steel	600 C
Minimum Lead-Bismuth Temperature	200 C
Leakage Detection Capability	
Passive Decay Heat Removal	

# ***Beam Window Nuclear Responses for 40 $\mu\text{A}/\text{cm}^2$ 600 MeV Protons***

**Energy deposition** 766.5 W/cm<sup>3</sup>

## **Atomic Displacement**

**Neutrons** 46.2 dpa/fpy

**Protons** 21.1 dpa/fpy

**Total** 67.4 dpa/fpy

## **Helium Production**

**Low energy neutrons < 20 MeV** 6 appm/fpy

**High energy neutrons > 20 MeV** 50 appm/fpy

**Protons** 1437 appm/fpy

**Total** 1493 appm/fpy

## **Hydrogen production**

**Low energy neutrons < 20 MeV** 6 appm/fpy

**High-energy neutrons > 20 MeV** 1010 appm/fpy

**Protons** 26753 appm/fpy

**Total** 27769 appm/fpy

# Lead-bismuth Target Design

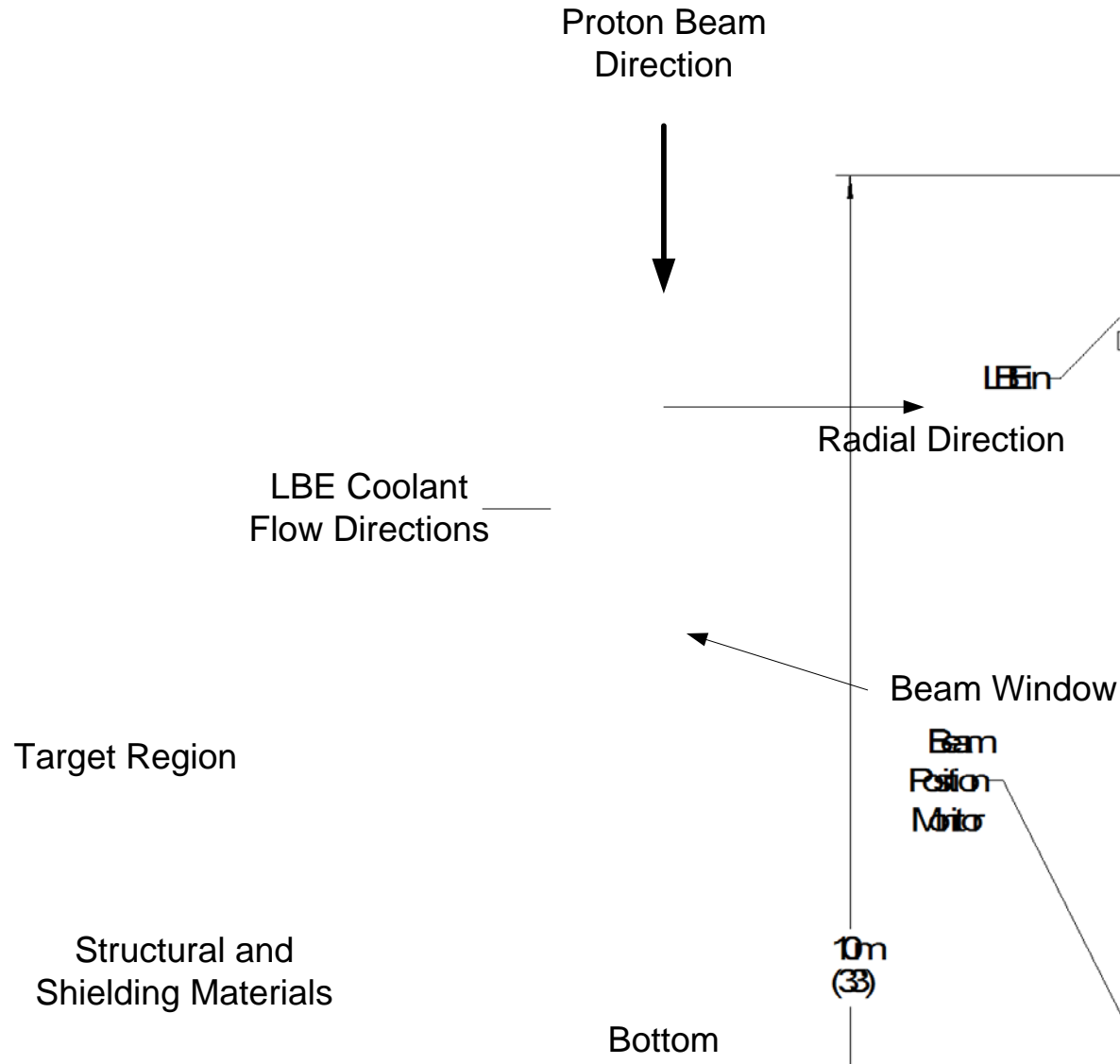

# Lead-bismuth Target Design

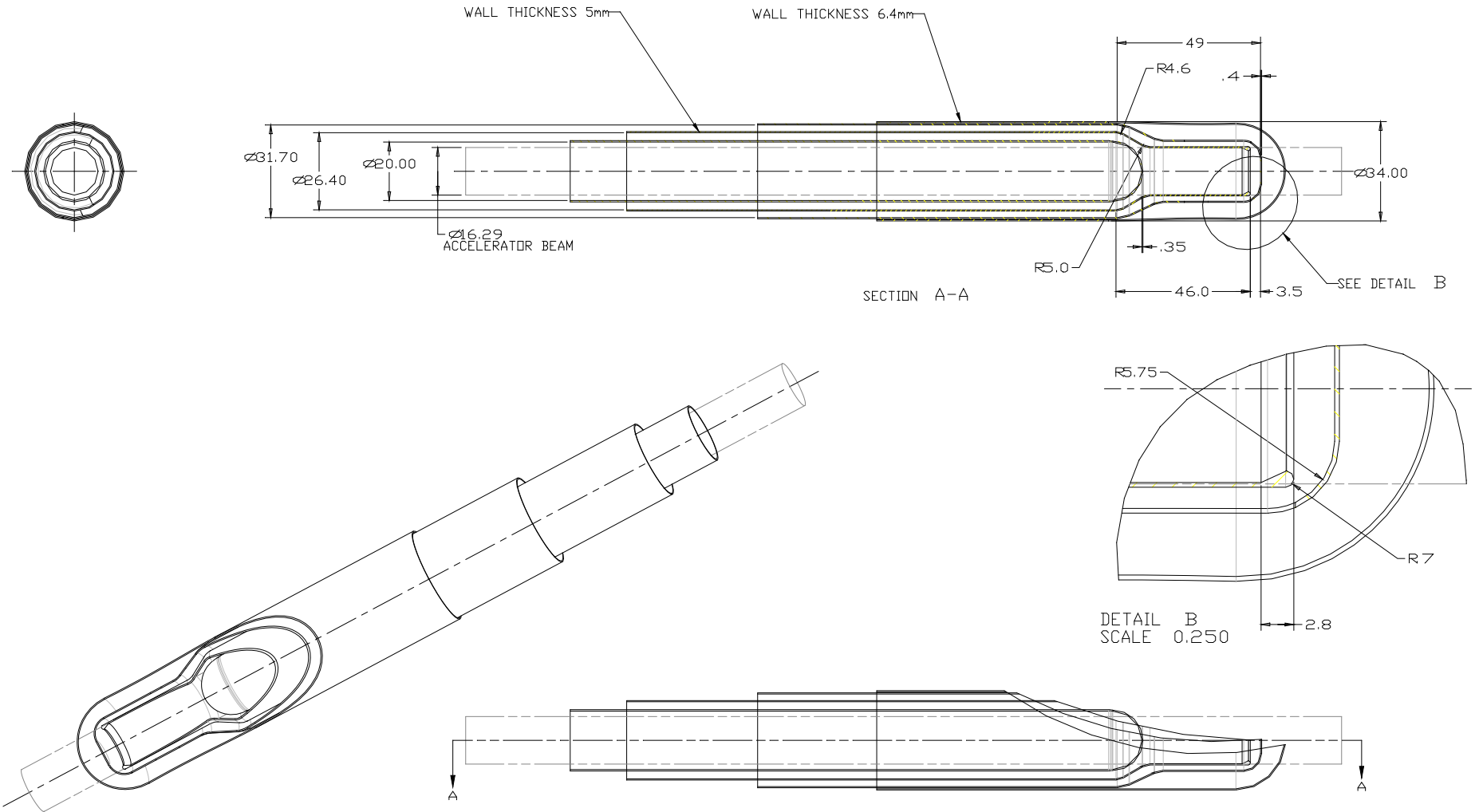



# *Buffer Analysis Conclusions*

- The number of spallation neutrons per proton has low sensitivity to the buffer thickness.
- The number of spallation neutrons reaching the multiplier is reduced as the buffer thickness is increased.
- The peak nuclear responses in the structural material at the buffer boundary show a good linear fit with the reciprocal of the outer buffer radius.
- The helium to atomic displacement ratio at the buffer boundary is in the range of 0.1 to 0.3 appm/dpa. In fast reactor spectrum, this ratio is about 0.26 for HT-9.
- The analyses show that a 7-cm buffer thickness protects the structural material from the nuclear responses caused by the high energy neutrons ( $E > 20$  MeV), does not impact the utilization of spallation neutrons, and has the required cross section area for the inlet and outlet coolant manifolds.

# *Thermal-Hydraulics Analyses*

Thermal-hydraulics Parametric analyses were performed to study the effect of the different design parameters and choices on the target performance including the following design variations:

- Two structural materials (SS316 and HT-9),
- Coolant inlet temperature,
- Flow path with respect to the beam window,
- Conical and hemi-spherical beam windows,
- Geometrical variations in the inclination of the middle walls and the conic beam window,
- Beam power spatial distributions

# ***The Thermal-hydraulics Analyses Conclusions***

- **The current design concept has a hemispherical beam window with a uniform thickness of 3.5 mm. All other structural components have a uniform thickness of 5 mm.**
- **The peak temperatures on the adiabatic and wetted surfaces of the beam window are 501 C and 340 C, respectively.**
- **The peak internal and surface temperatures of the middle wall are 456 C and 390 C, respectively.**
- **The outlet temperature of LBE is 280°C for an inlet temperature of 200°C.**
- **The total pressure drop in the target is 32 psi.**
- **Flow control methodologies are employed to increase the stability of the flow field.**

# Lead Bismuth Eutectic Target Contour Plots Showing

## Fluid Velocity

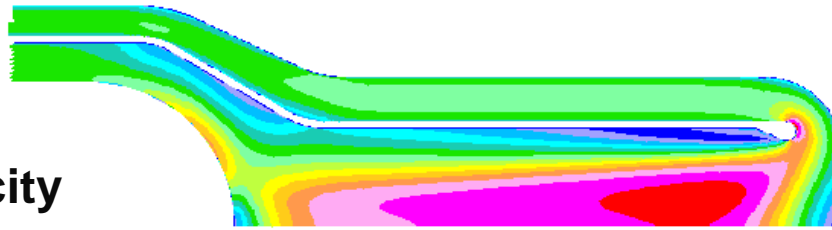

VELOCITY MAGNITUDE  
M/S

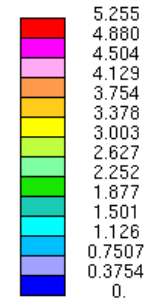

## Fluid Temperature

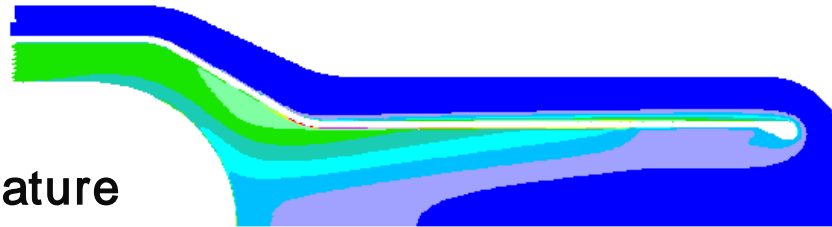

TEMPERATURE  
ABSOLUTE  
KELVIN

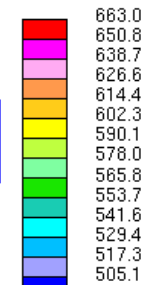

## Structural Temperature Profiles

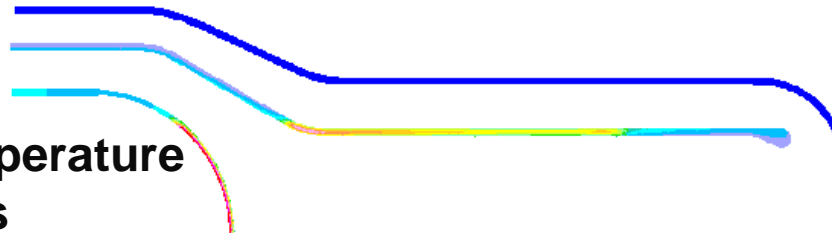

TEMPERATURE  
ABSOLUTE  
KELVIN

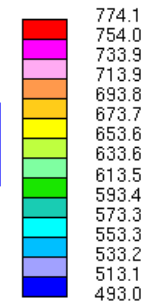

# *Conclusions*

- **A Lead-Bismuth Eutectic target design was successfully developed for generating neutrons to drive a subcritical assembly.**
- **The target design objectives and constraints were defined and satisfied.**
- **The target design concept has a coaxial geometrical configuration and HT-9 structural material.**