

# LBNE 1.2MW TARGET CONCEPTUAL DESIGN

Brian Hartsell, Kris Anderson, James Hylen



## LBNE Experiment/Introduction

LBNE (*Long Baseline Neutrino Experiment*) will send a high intensity neutrino beam 800 miles ( $\approx 1300$  km) to a multi-kiloton volume of liquid argon. LBNE is expected to be fully constructed and ready for operations in 2022. The proposed beamline is shown in Figure 1.

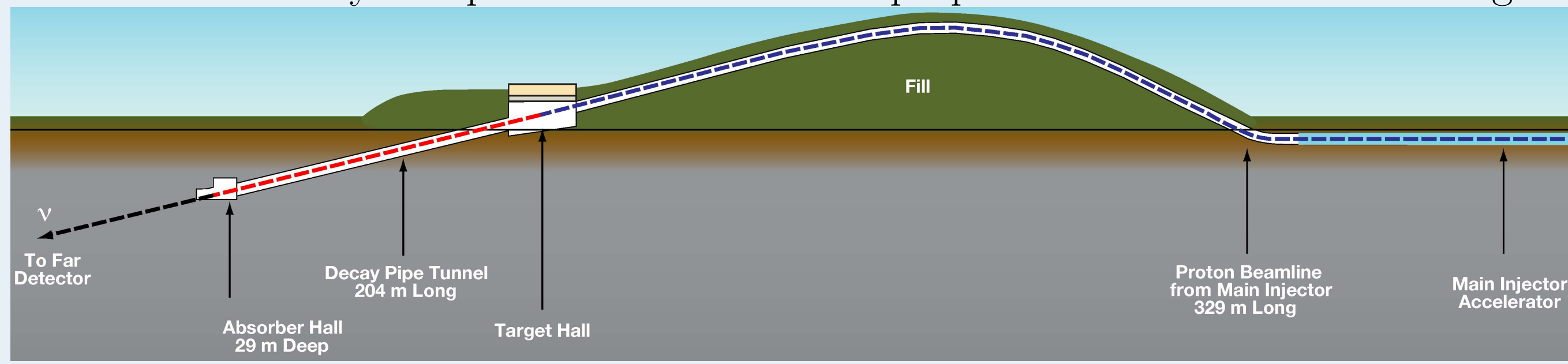

Figure 1: LBNE Beamline Layout

To produce the particles that eventually decay into neutrinos, a proton beam interacts with a graphite target. A concept for this target will be presented and analyzed.

## Target Layout

The target is comprised of 48 graphite segments brazed to dual grade 2 titanium water cooling lines. Figure 2 shows a cross section of this assembly through a graphite segment. This assembly is then placed inside a sealed beryllium canister which is placed under vacuum and back-filled with helium to provide an inert environment to prevent corrosion.

Dimensions of the target were scaled up to provide a consistent peak proton flux compared to the original IHEP NuMI LE target design<sup>1</sup>, resulting in a 1.7mm beam sigma and 10mm wide fins.

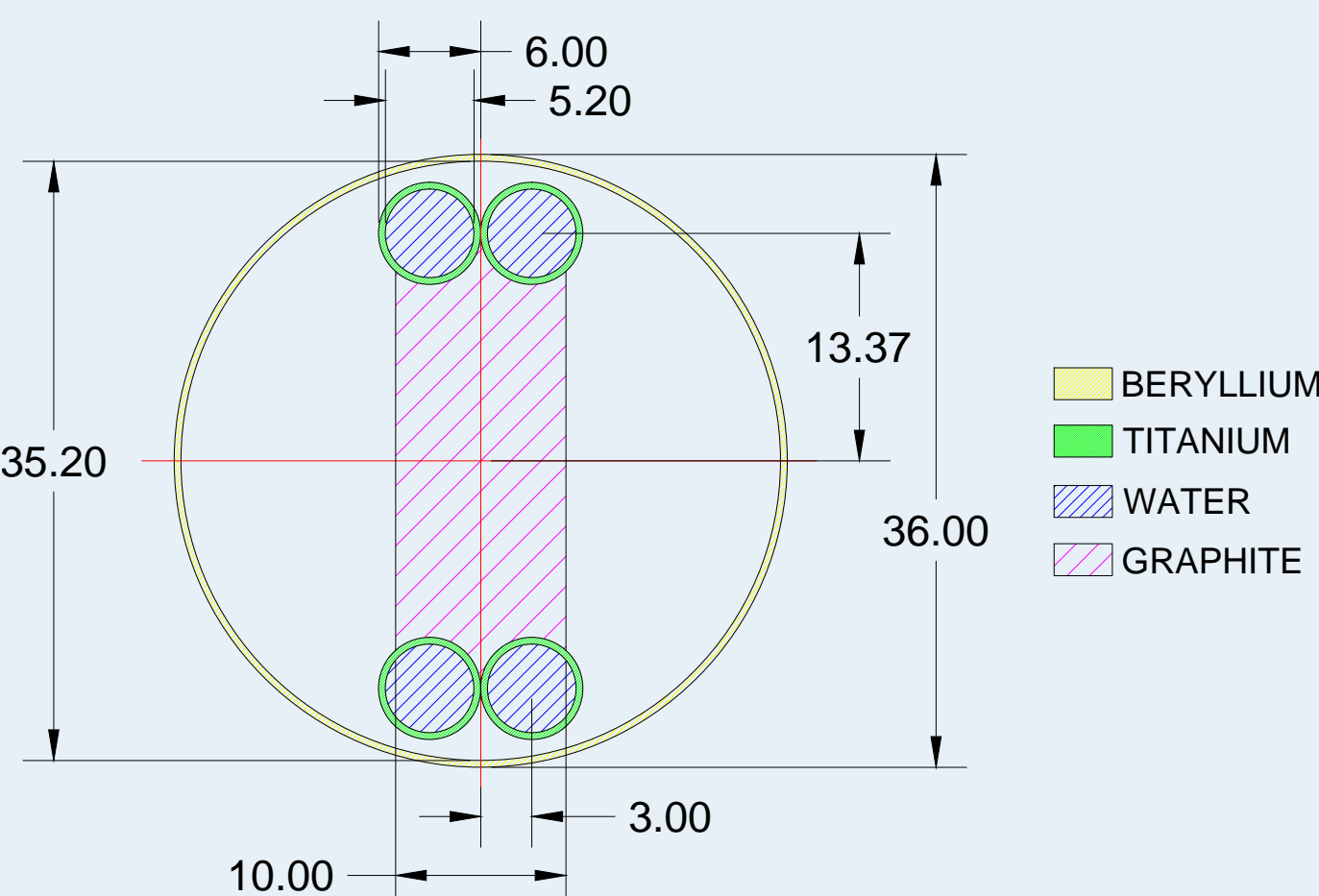

Figure 2: 1.2MW Target Cross Section

## Energy Deposition

Energy deposition is used to calculate the heat load placed in the target at each fin. A detailed map of energy deposition was provided by Diane Reitzner using MARS15 and a graphical representation of the data is shown in Figure 3.

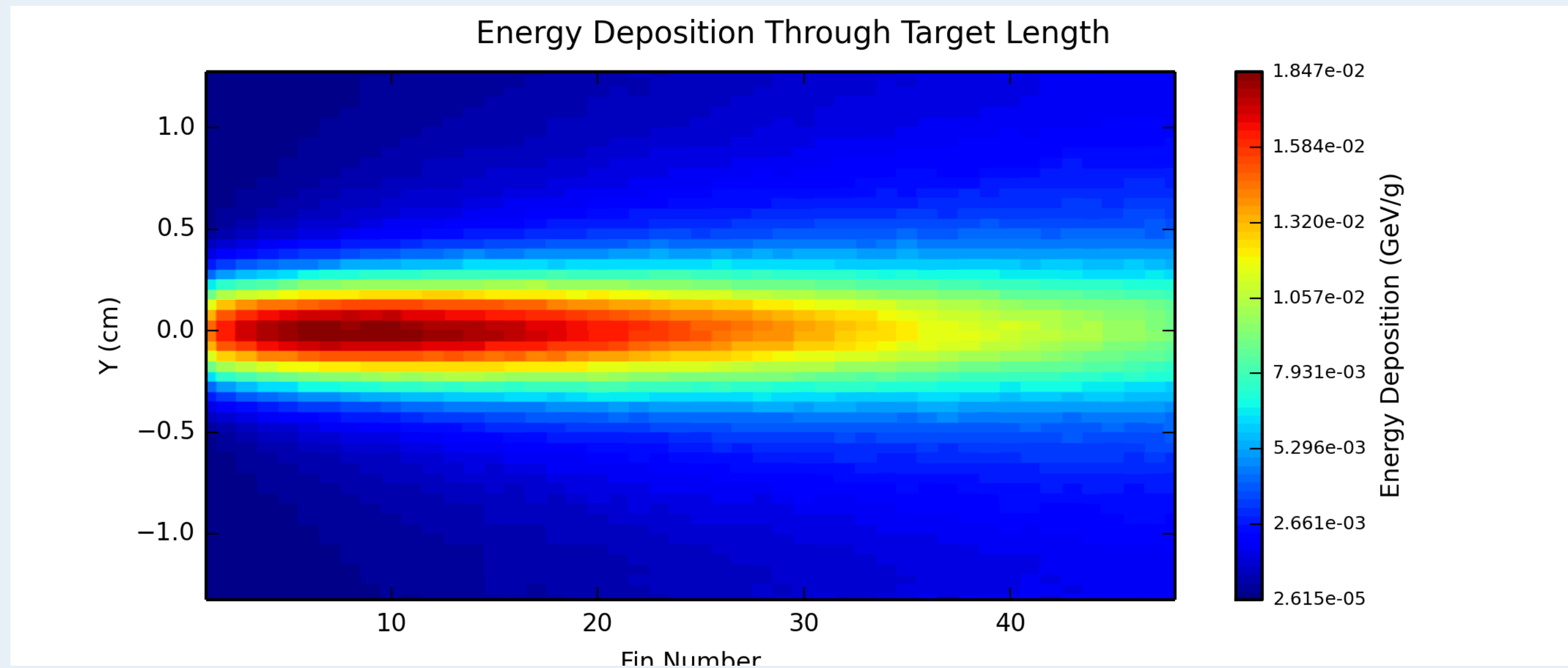

Figure 3: Energy deposition (GeV/g) along Y-Z

## Fin Stresses & Temperatures

Temperatures and stresses were evaluated in the worst case fin. This is defined as the fin with the largest energy deposited in the 1 sigma area and a steep temperature gradient. This worst case occurs between fins 6 and 10 (with fin 1 being defined as the most upstream fin). Fin 8 was selected for further analysis. Temperature at the center of the beam and at the water line is shown in Figure 4. The maximum temperature rise at the center of the fin is about 215°C. Stress after a beam pulse is shown in Figure 5, with a maximum stress of about 10 MPa that occurs about 2/3 of the way around the curved radius of the fin. The tensile strength of this material is about 80 MPa.

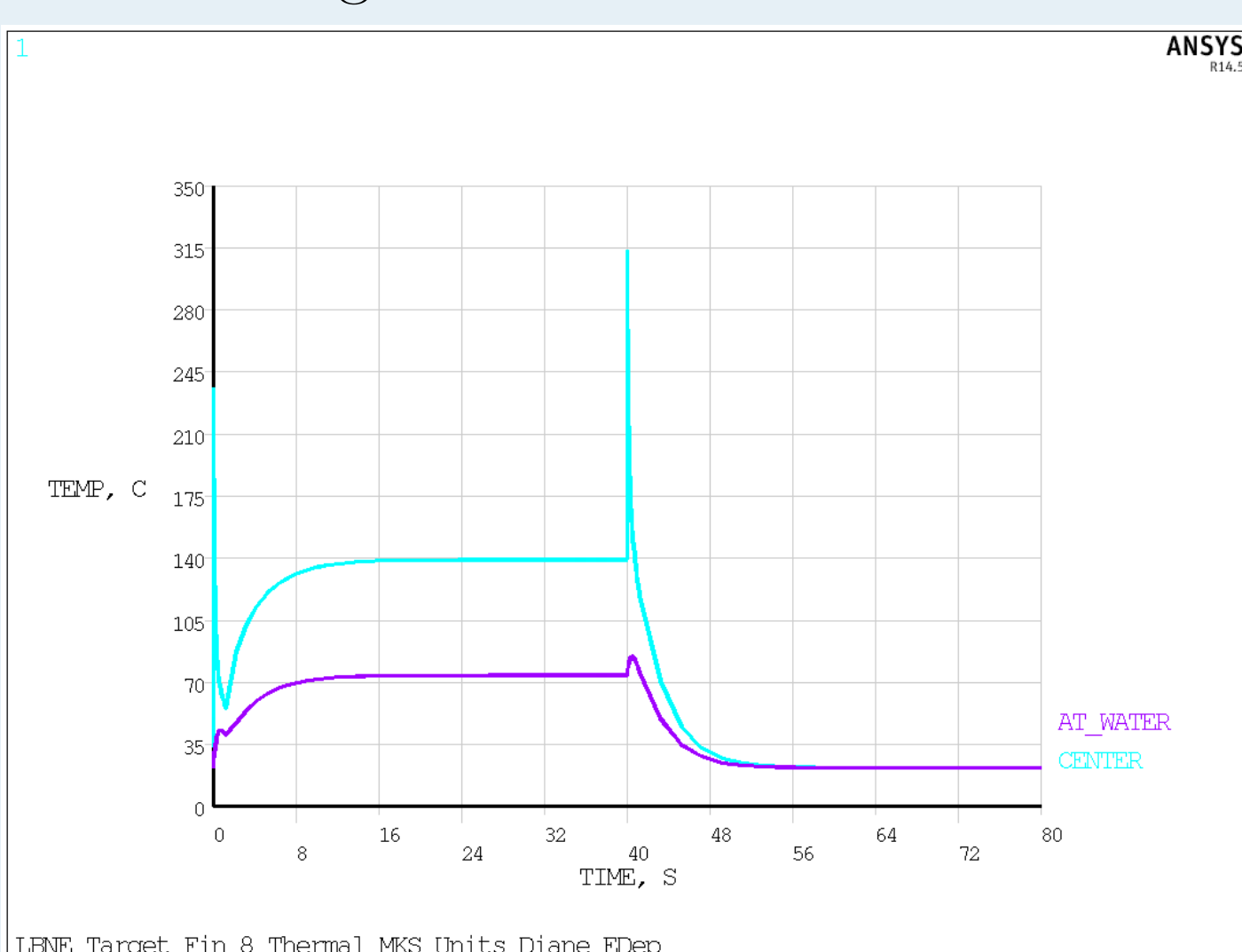

Figure 4: Temperature (°C) vs time for two nodes

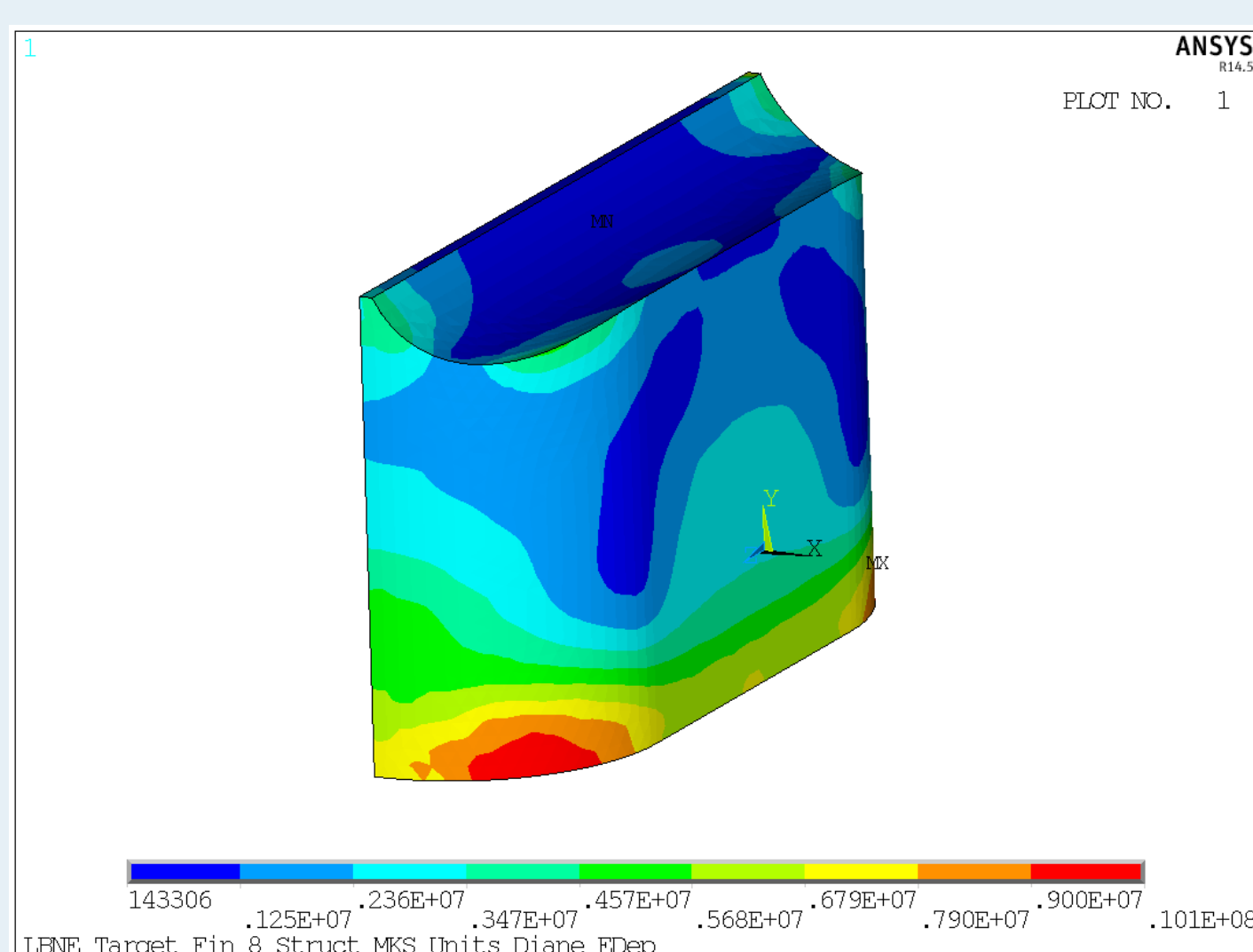

Figure 5: Von-Mises stress (MPa)

## Titanium Water Lines

Grade 2 titanium water lines are being considered for this design as proposed by the RAL HPT group<sup>2</sup>. Steady state stresses were considered for this preliminary analysis due to the small temperature rise at the water line shown in Figure 4. The maximum stress shown in Figure 7 occurs between each fin due to the large temperature gradient shown in Figure 6 as well as a thermal expansion mismatch.

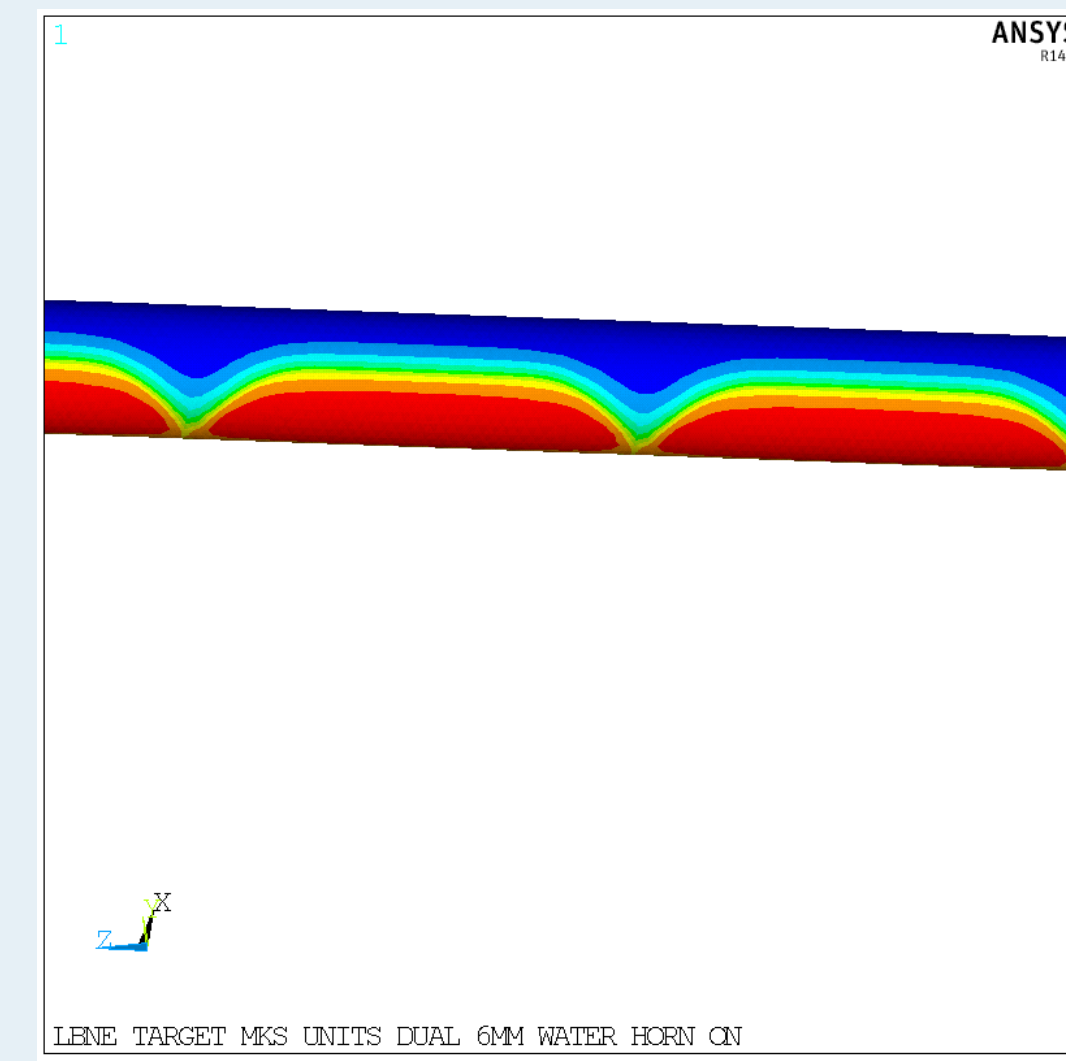

Figure 6: Temperature (°C) in water lines

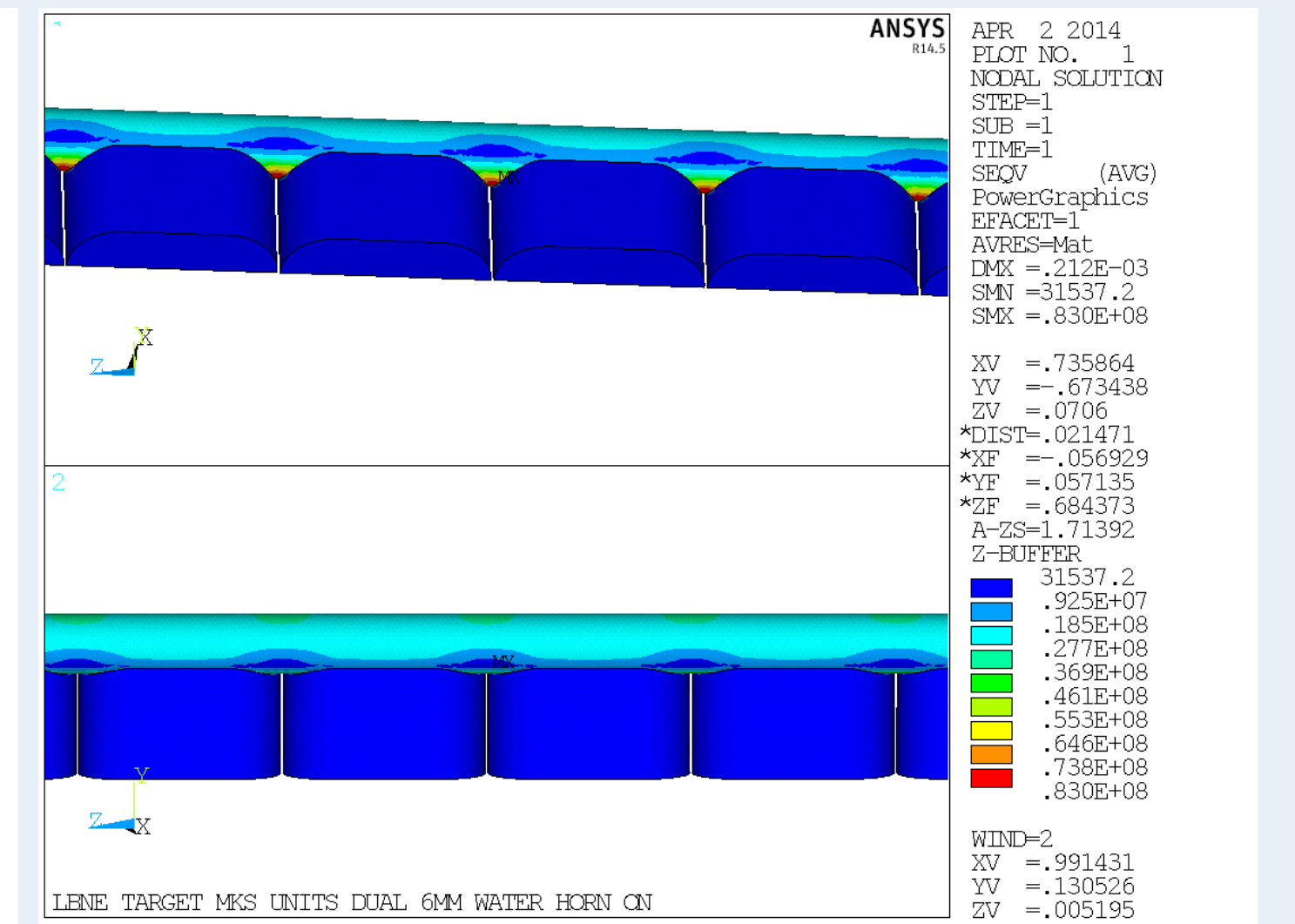

Figure 7: Von-Mises stress (MPa) in water lines

Fatigue is considered as the failure criteria for this section, but a cycle only occurs when the target cools from steady state. A more detailed transient analysis that accounts for the heating of the water line and water due to beam showering is in process and will be able to determine any high cycle fatigue issues.

## Target Canister

Energy deposition values were only available from the existing MARS run as average values over the beryllium canister and window. The canister energy deposition was scaled relative to the deposited energy in the target as shown in Figure 8, leading to more heating in the downstream end of the canister.  $\Delta T$  values for each pulse are on the order of 5°C, so this case is dominated by the steady state effects.

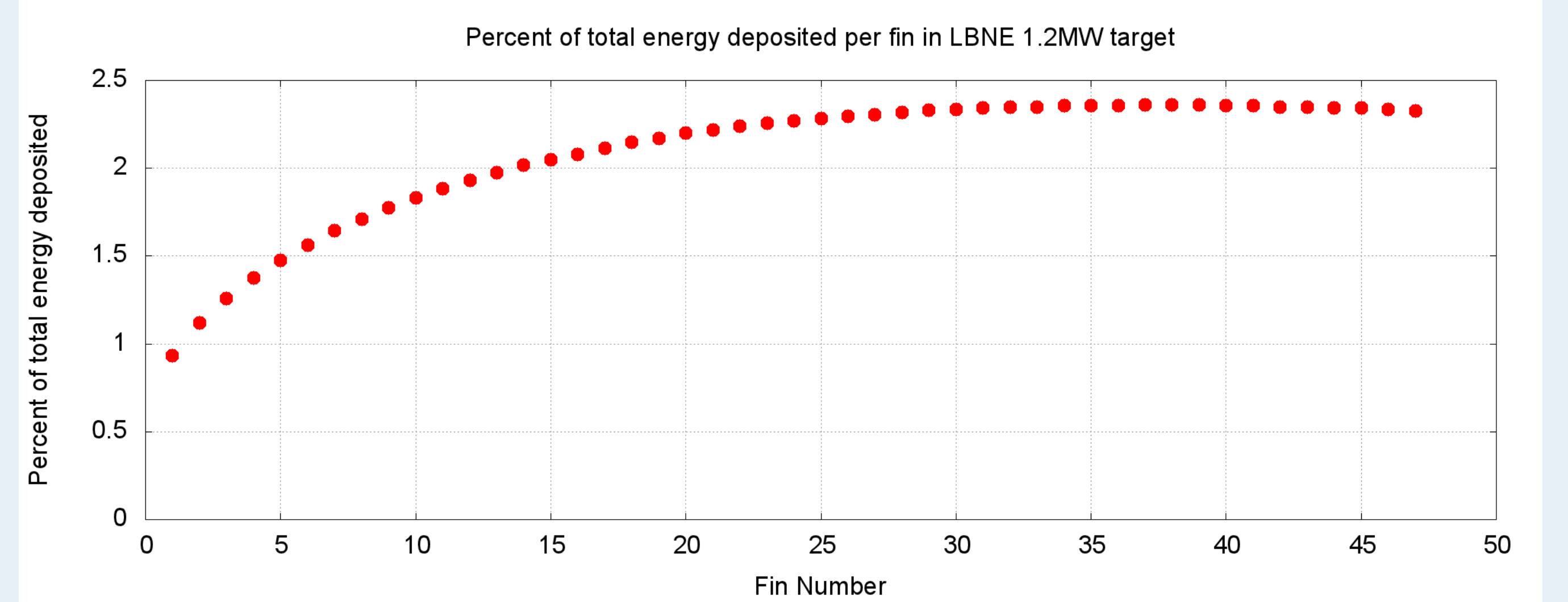

Figure 8: Target energy deposition per fin

Resulting temperatures and Von-Mises stresses are shown in Figures 9 and 10. These stresses are low for the temperature ranges considered.

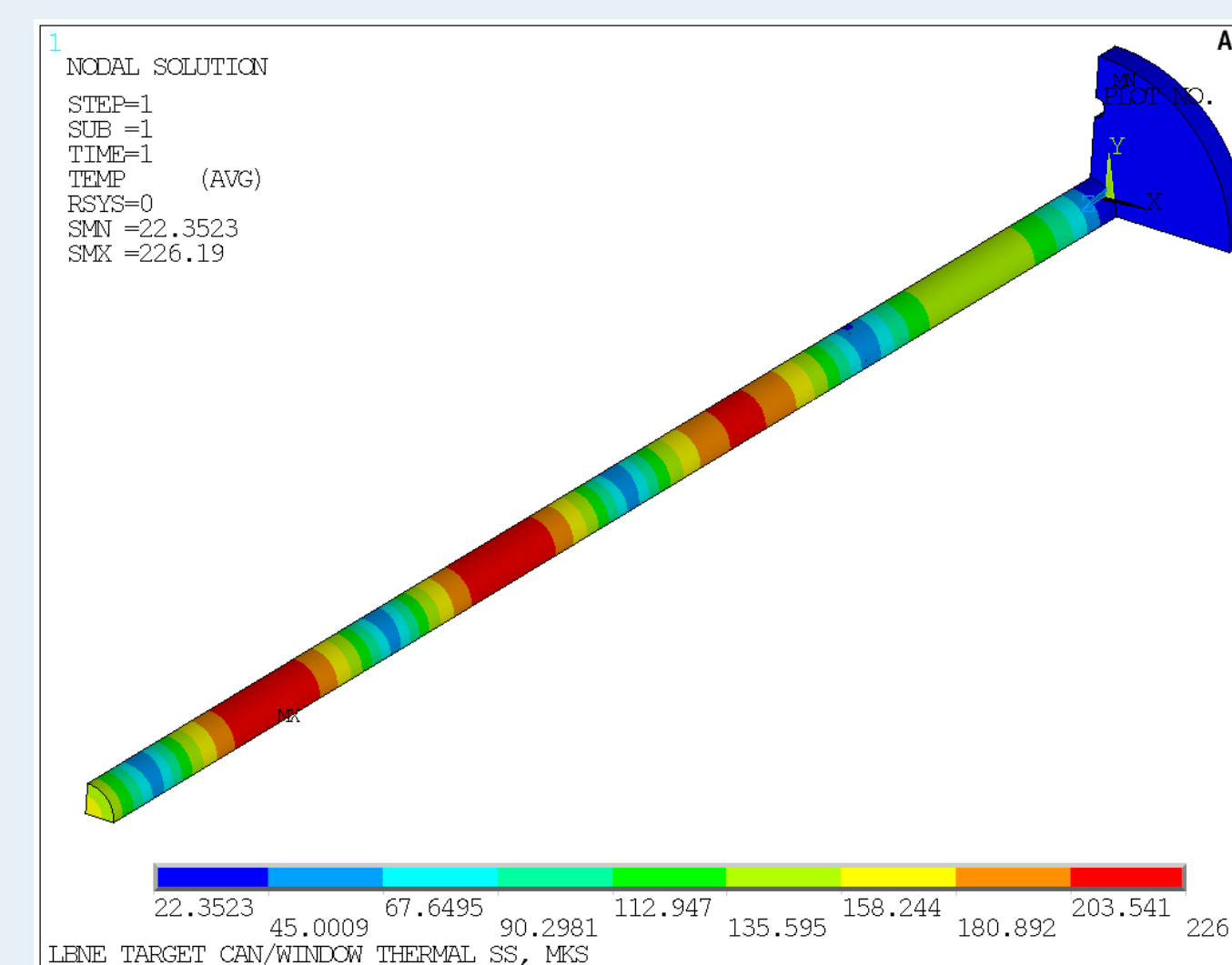

Figure 9: Thermal (°C) results for target canister

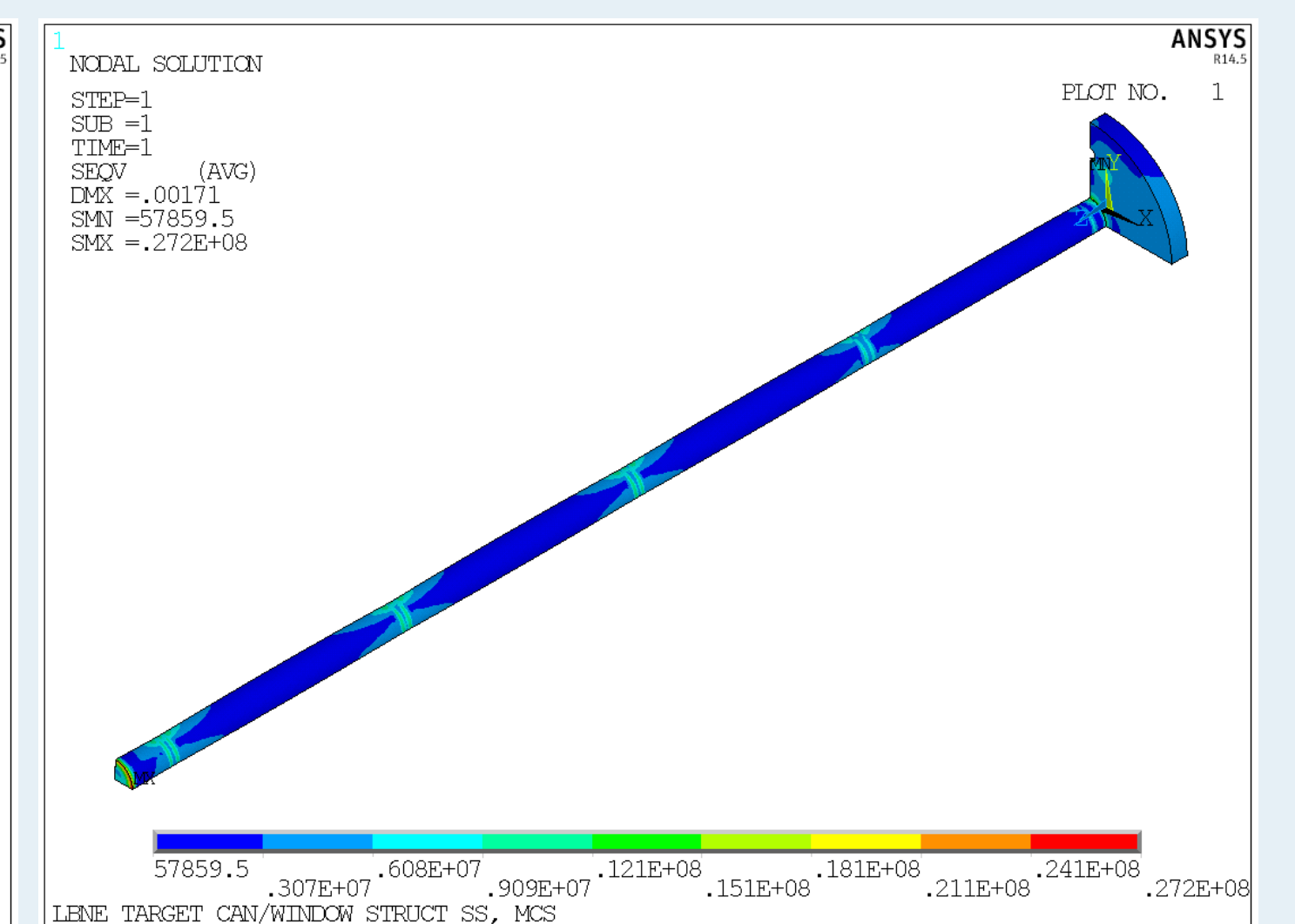

Figure 10: Von-Mises stress (MPa) for target canister

## Conclusions

Through these analyses it has been shown that the proposed conceptual design for a 1.2MW target appears viable but needs some further analysis to say this for certain. Since fin stresses are relatively low, further optimization of the neutrino production may be studied by reducing the beam sigma and the target width.

Water lines are lowest safety factor item in the target, and further analysis is pending to fully characterize the water line cyclic stresses and water hammer effects. Stresses in the target canister appear low and temperatures are reasonable.

## References

- [1] A. Abramov et al, "Dynamic Stress Calculations for ME and LE Targets and Results of Prototyping for the LE Target"
- [2] O. Caretta et al, "Thermo-mechanical analysis study of the NuMI/MINOS Low Energy Target Cooling Circuit"