

Fission target handling system

L. Serbina, E. Udup, F. Negoita (NIPNE-Bucharest)

L. Tecchio (INFN-Legnaro)

MAFF Concept

O. Kester
P. Thirolf
W. Assmann
M. Groß
D. Habs
(LMU)

MAFF Source side

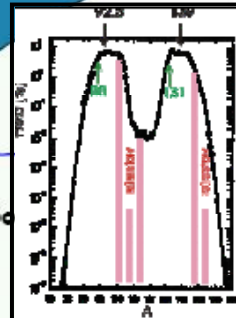
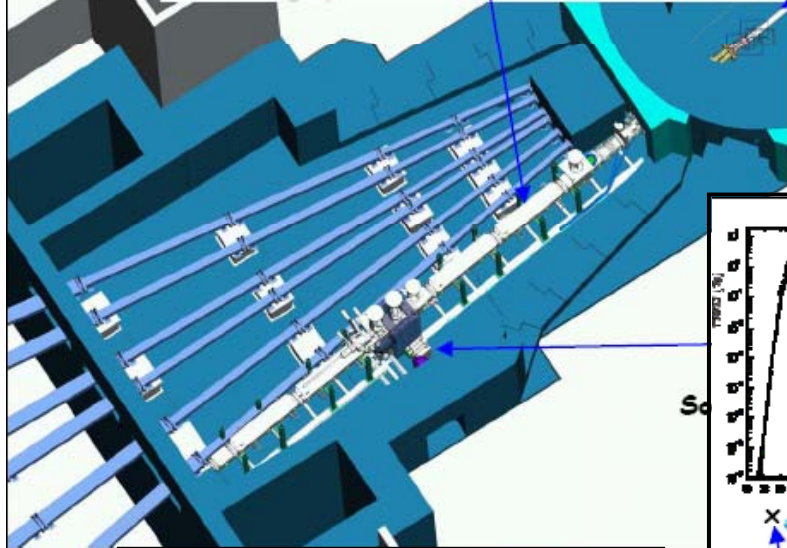
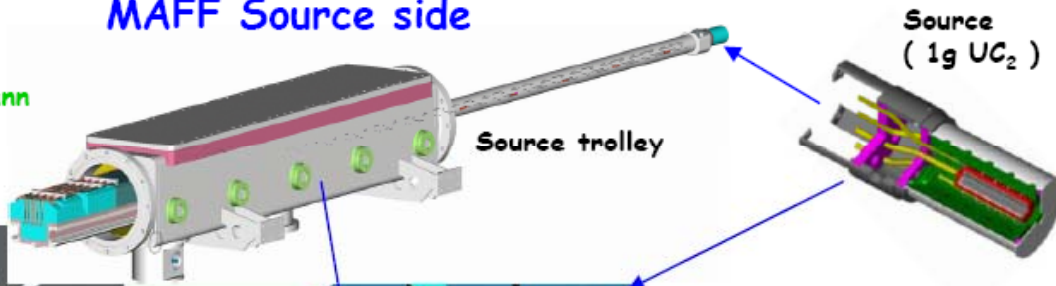

MAFF Extraction

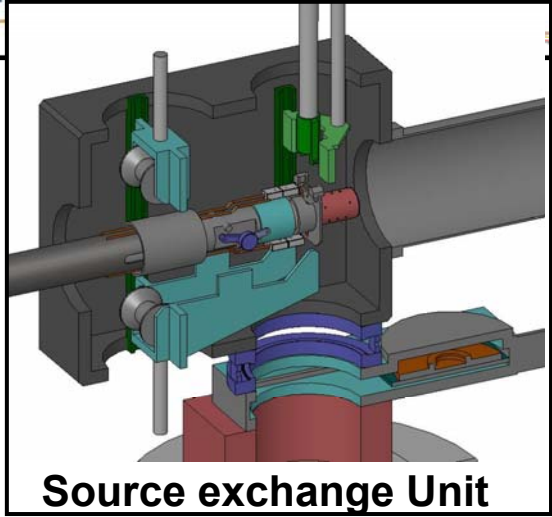
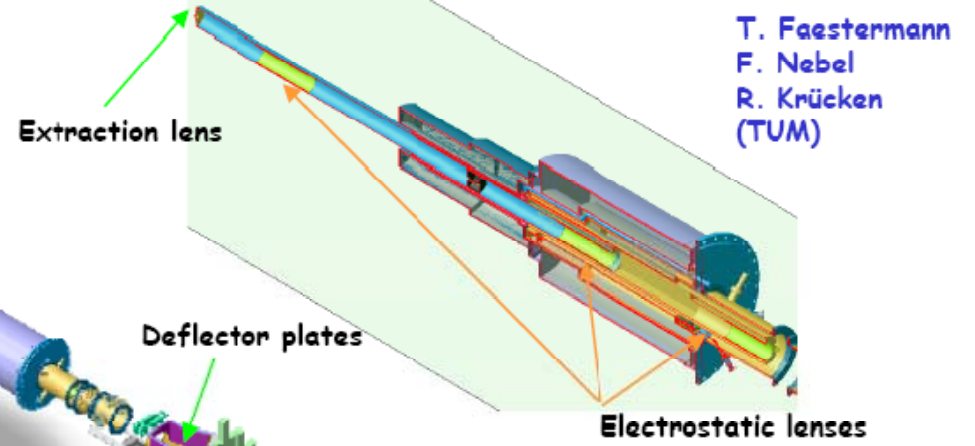

Fission source
10¹⁴ fission/sec

Mass separator



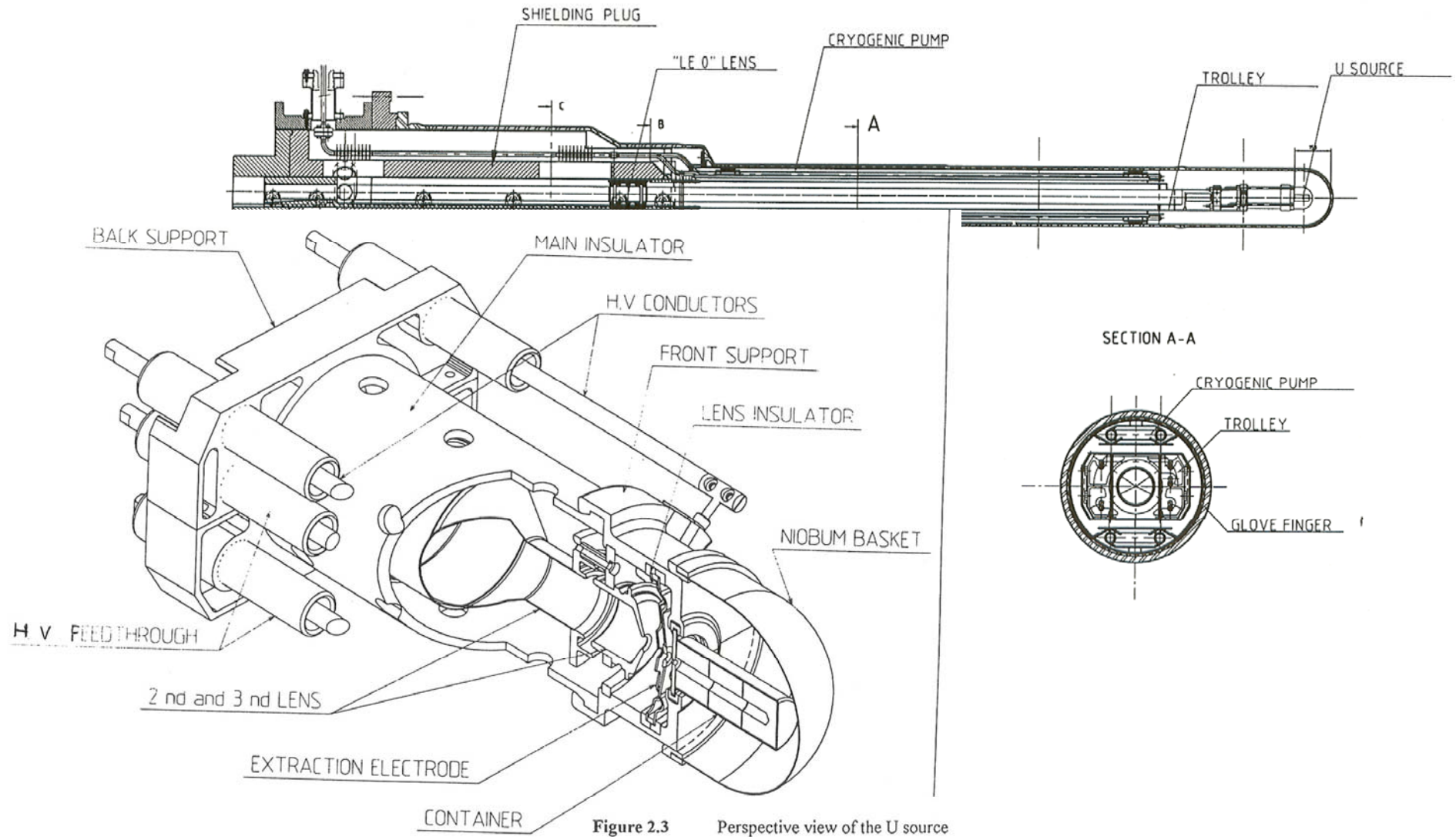
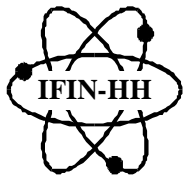
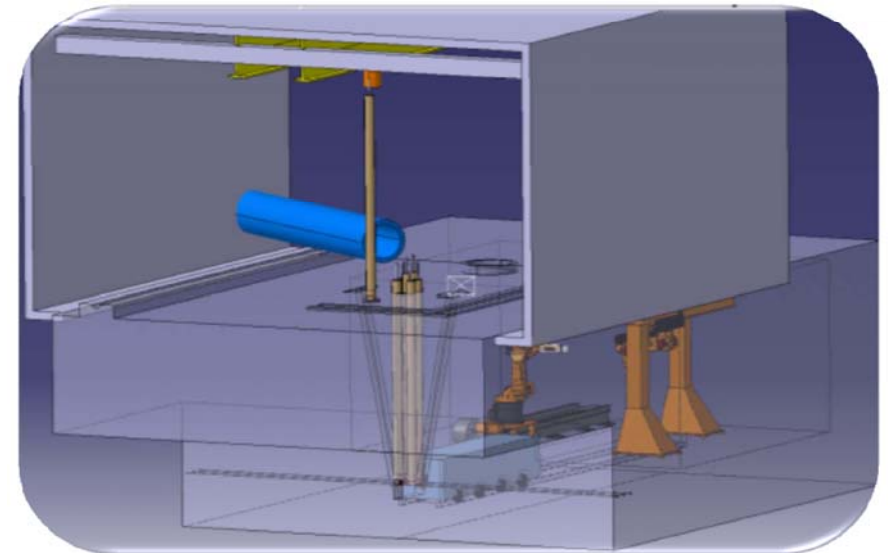
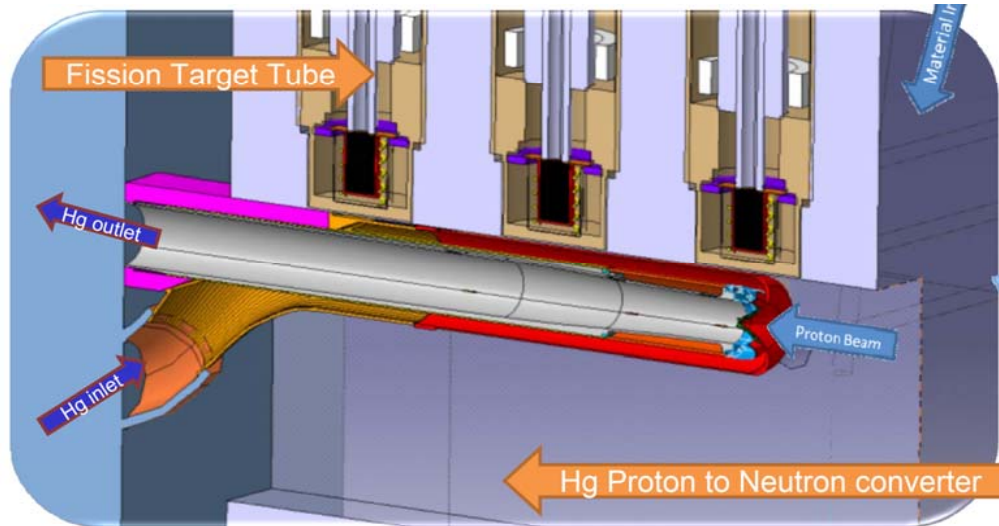
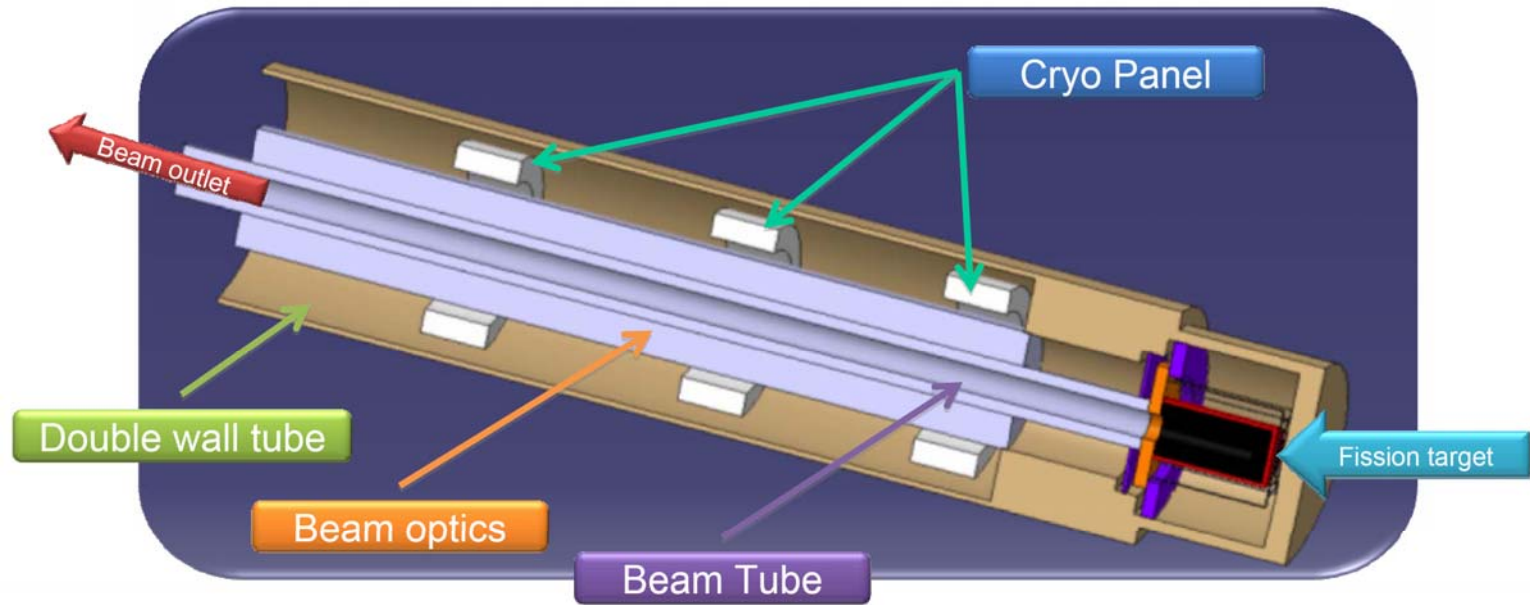

Figure 2.3 Perspective view of the U source



Integration of MAFF Concept





Assembly view of previous design (one year old)

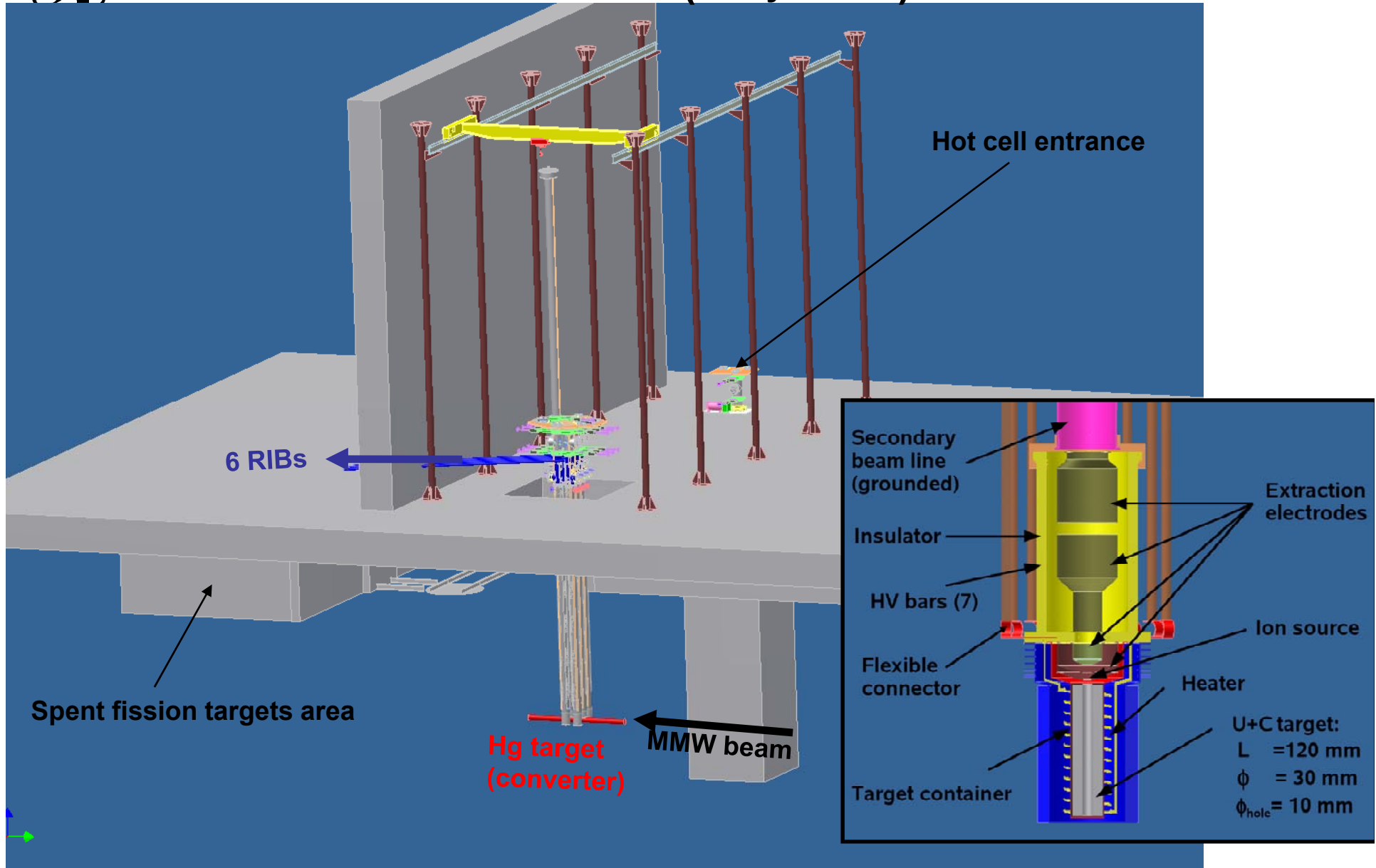



Details of previous design

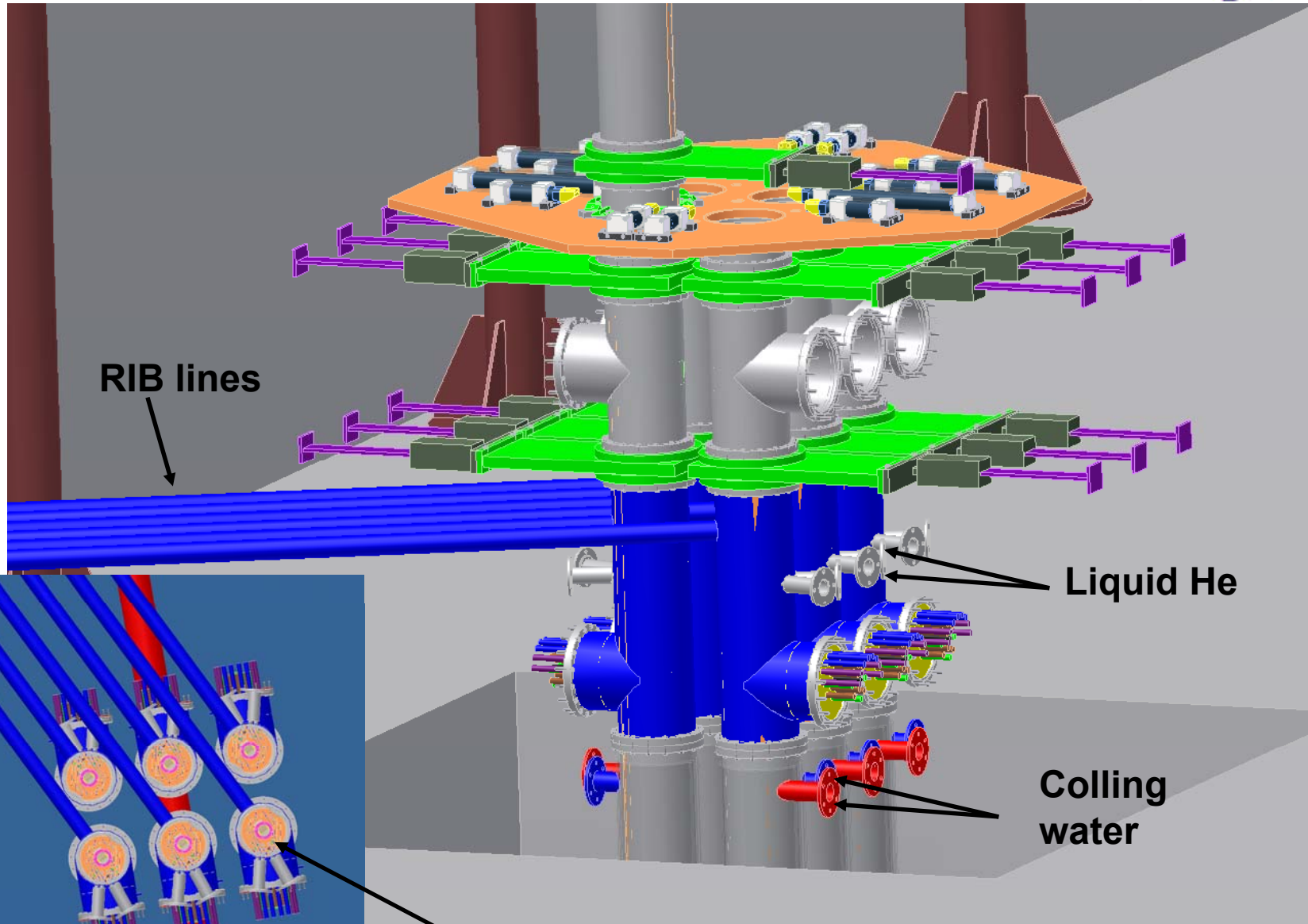

Fission targets too far from converter



Current design: tilted rectangular tubes

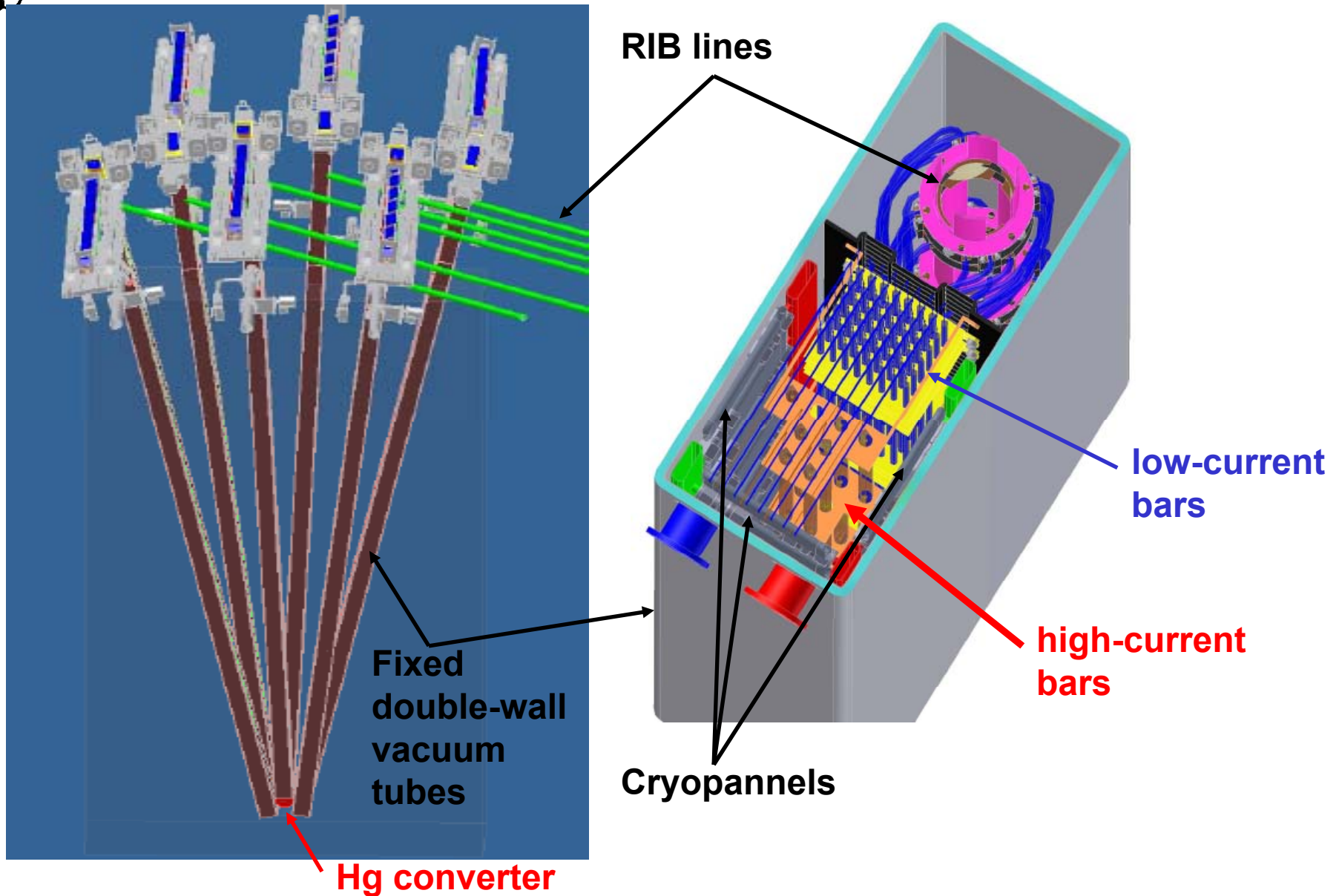



Current design: tilted rectangular tubes (II)

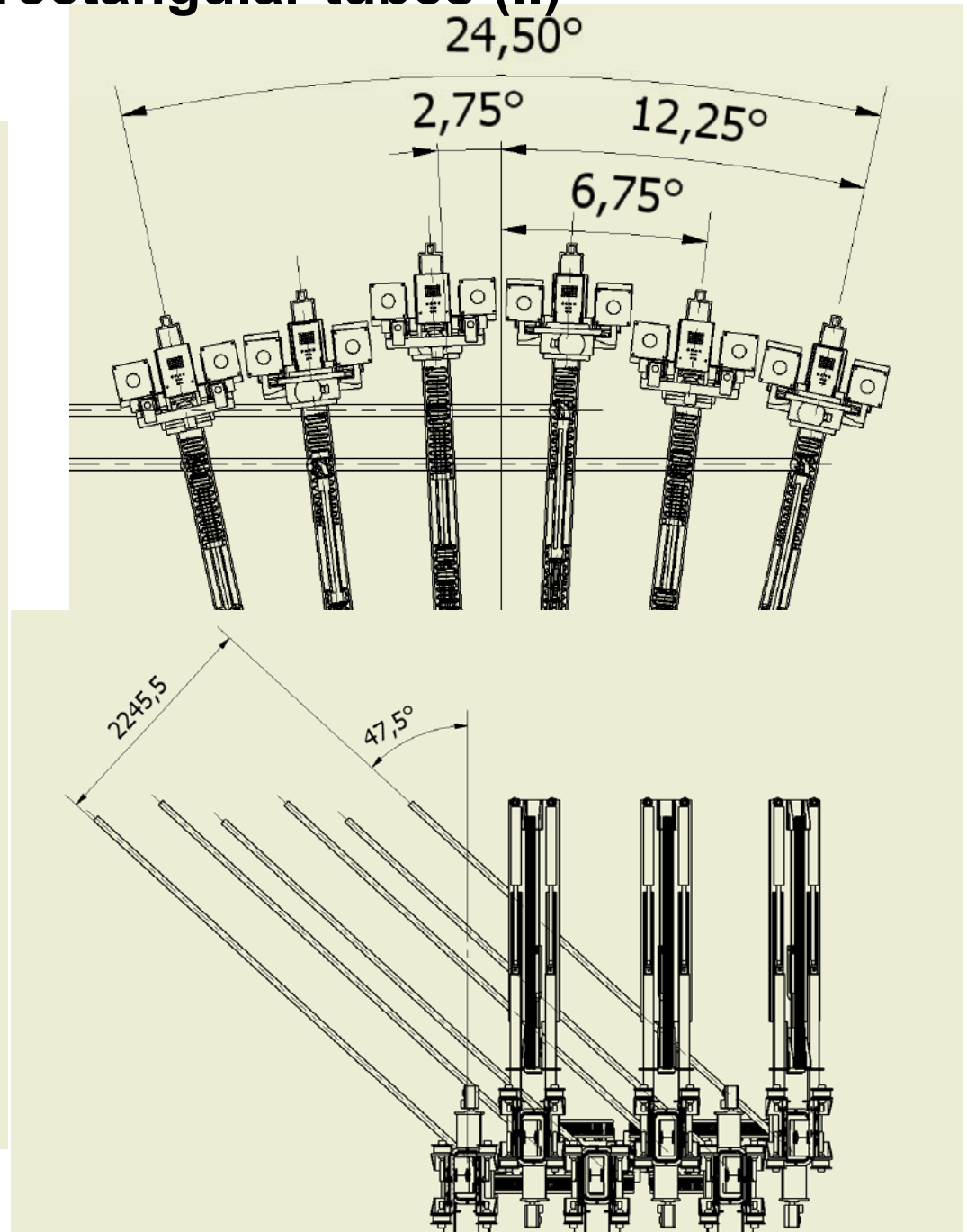
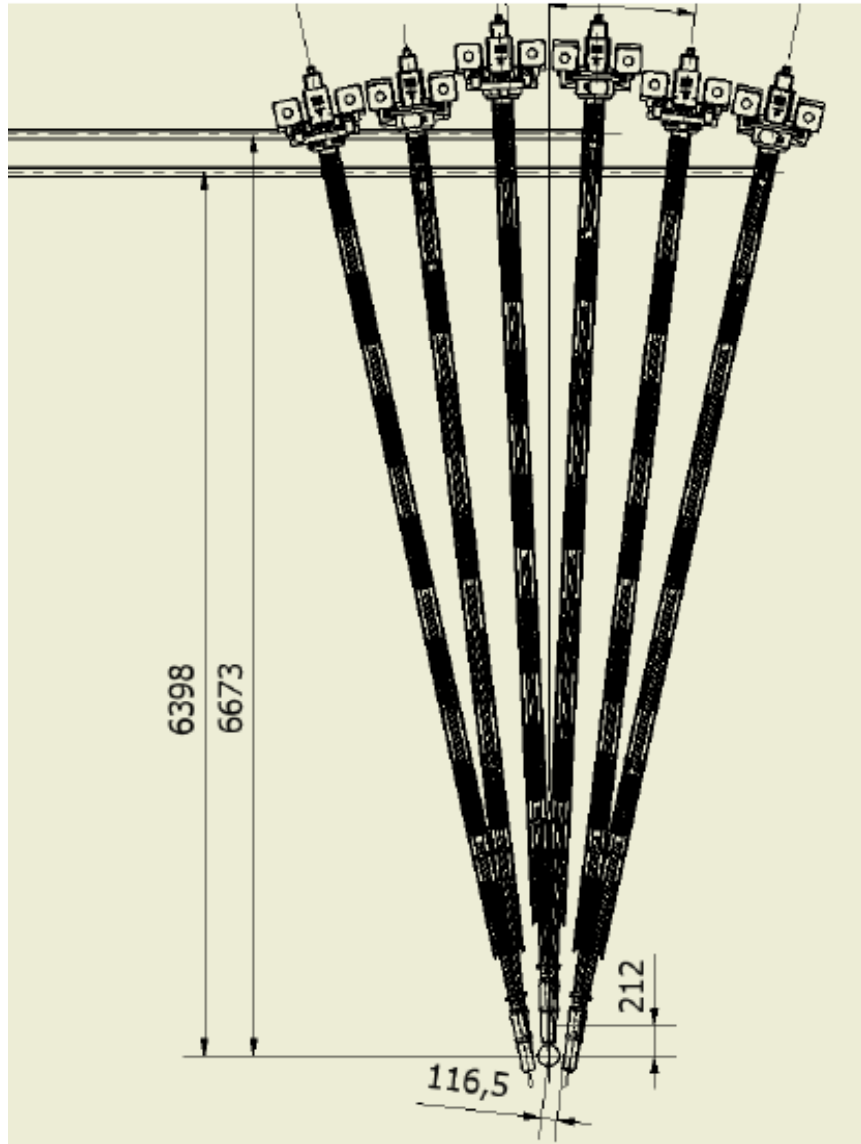



Slight modifications at the level of fission target - ion source - extraction

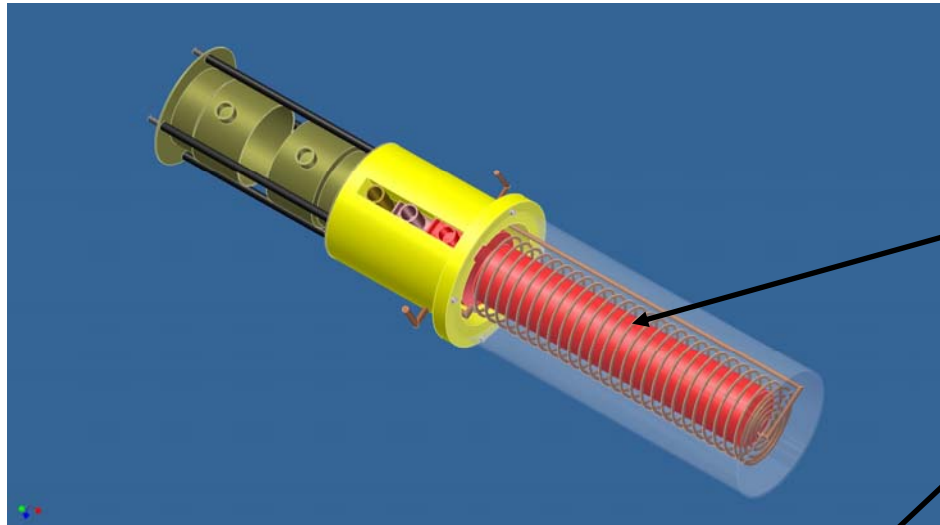

U+C target:

L=200 mm

$\Phi = 30$ mm

$\Phi_{\text{hole}}=8$ mm

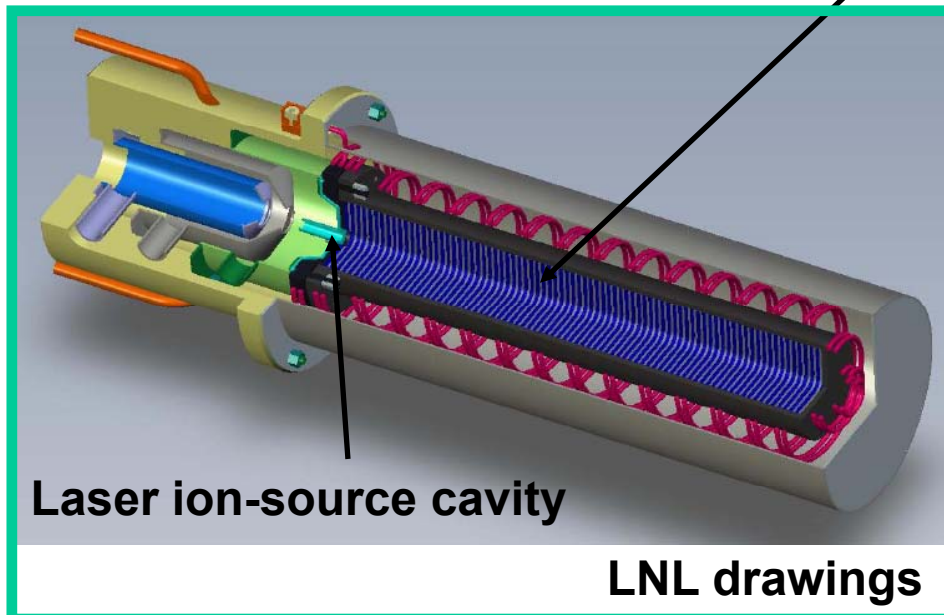

Heating spiral extended on bottom side become diagnostic tool for target break or failure:

- if $R_{\text{spiral}} = \infty$
- or $R_{\text{spiral-inner container}} = 0$
- or $R_{\text{spiral-outer container}} = 0$

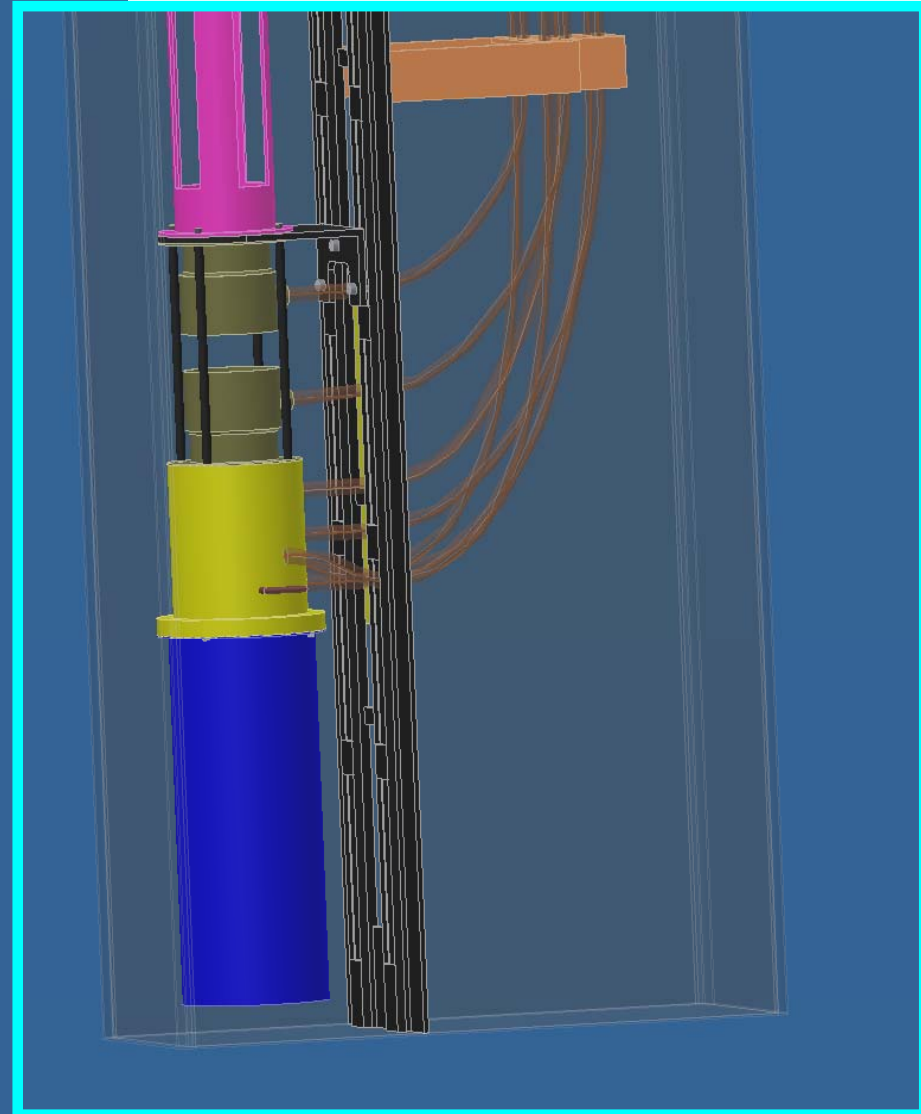
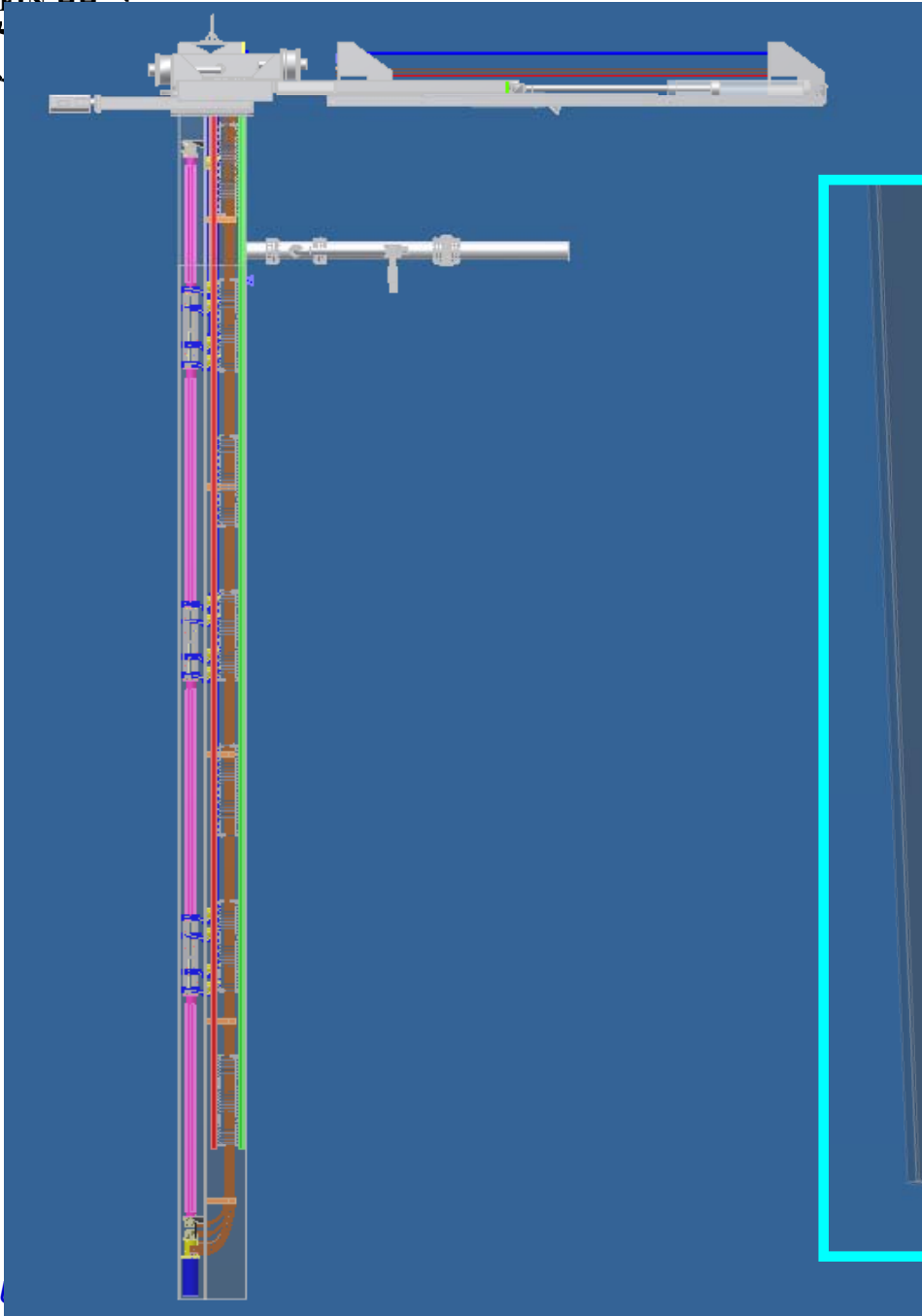

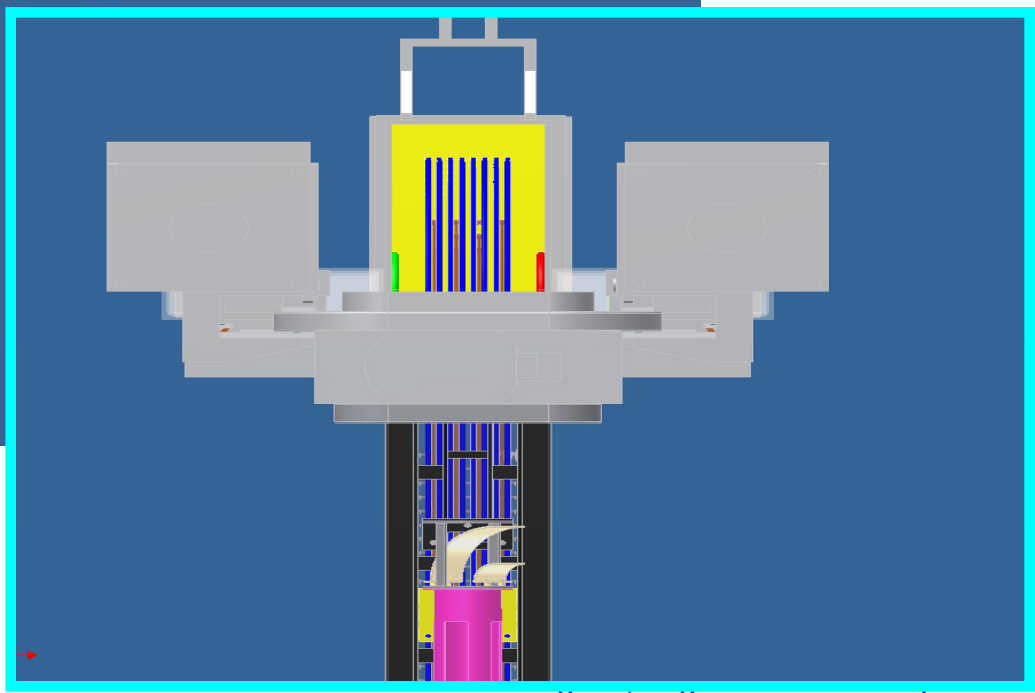
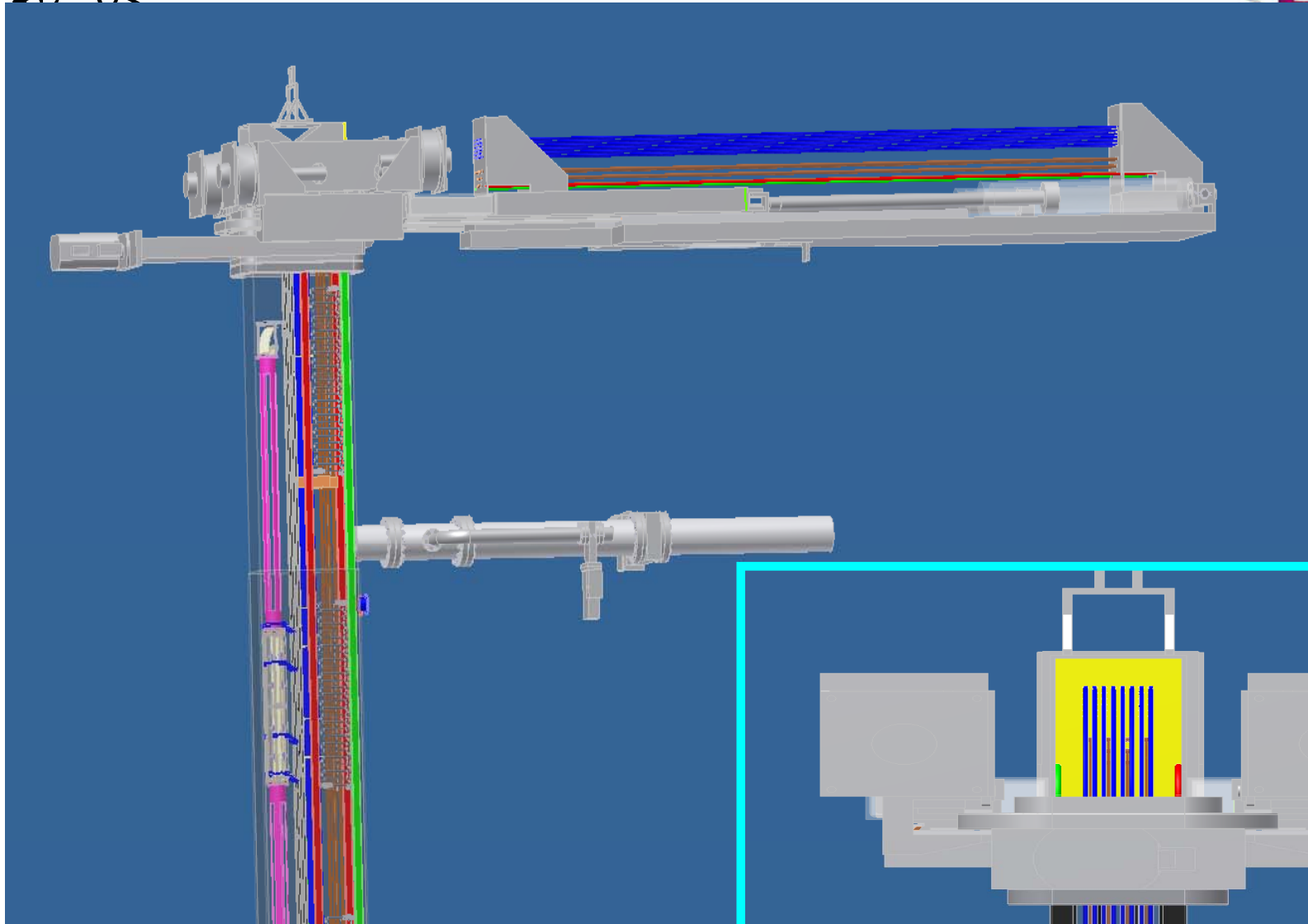



Laser beam path

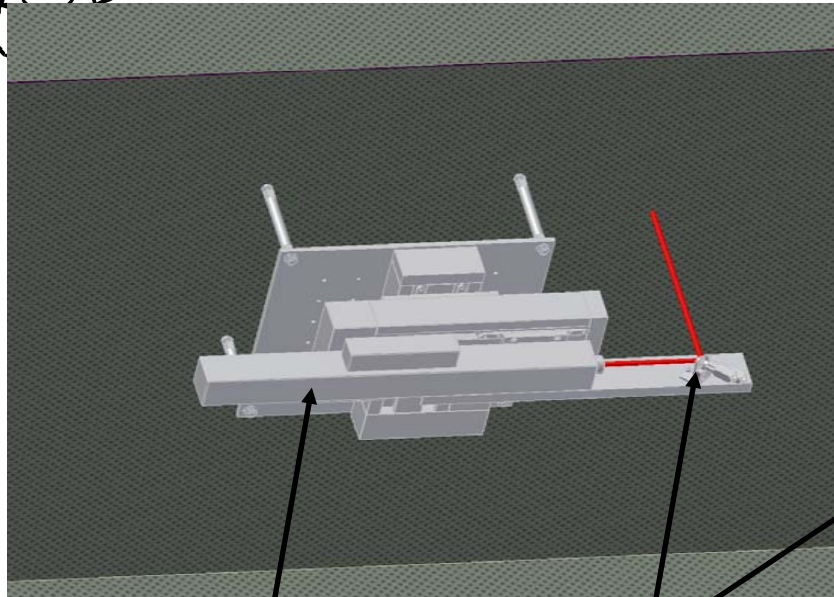

Laser

Mirrors

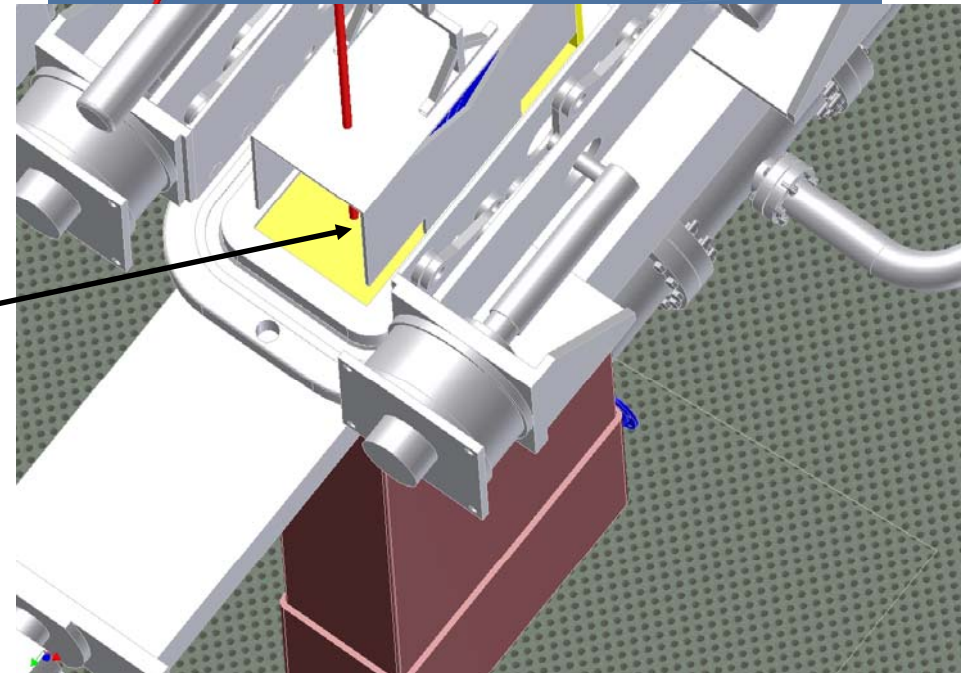
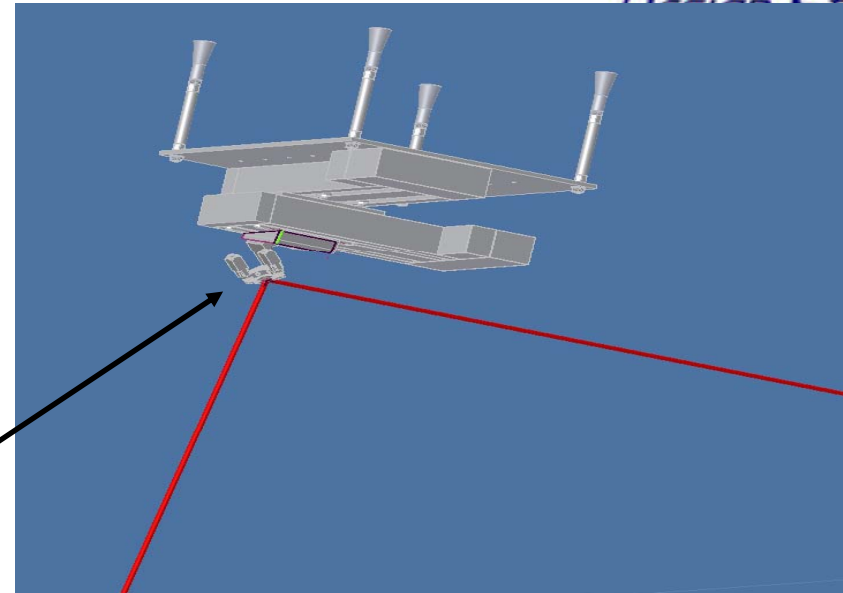

An window
to be added



Assembly view of new design

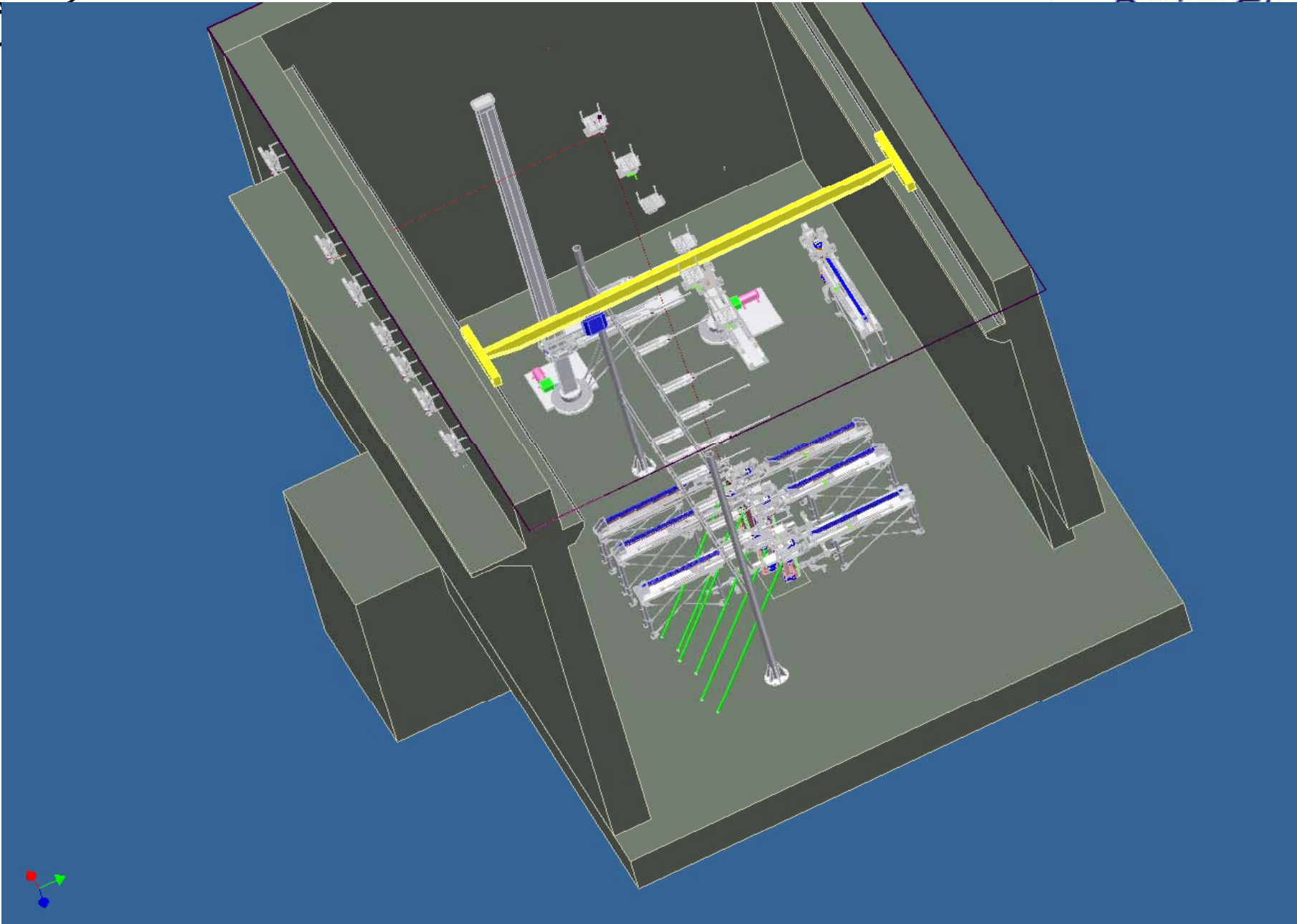

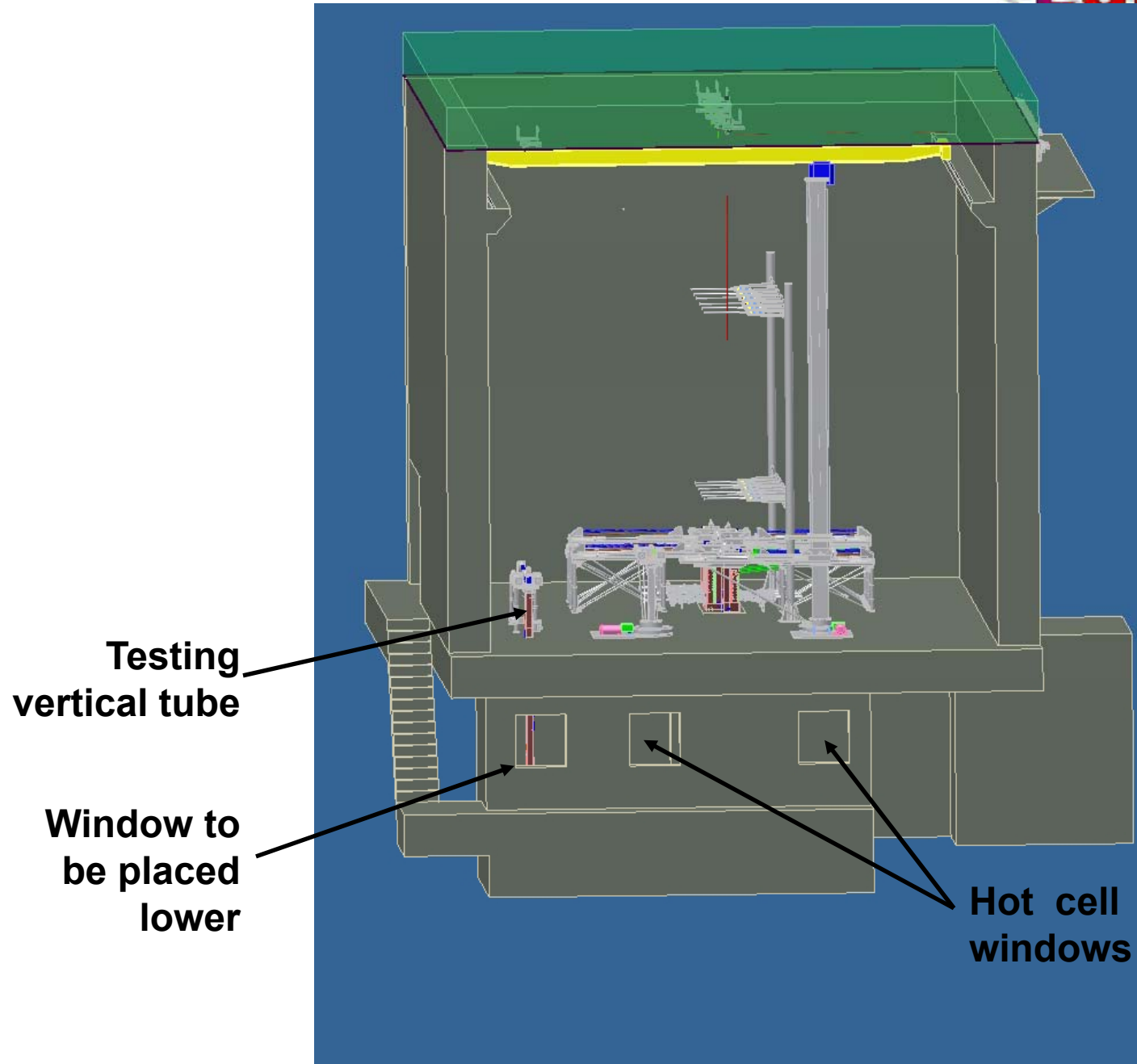
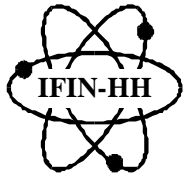



Remove cryopanel independently on target ?

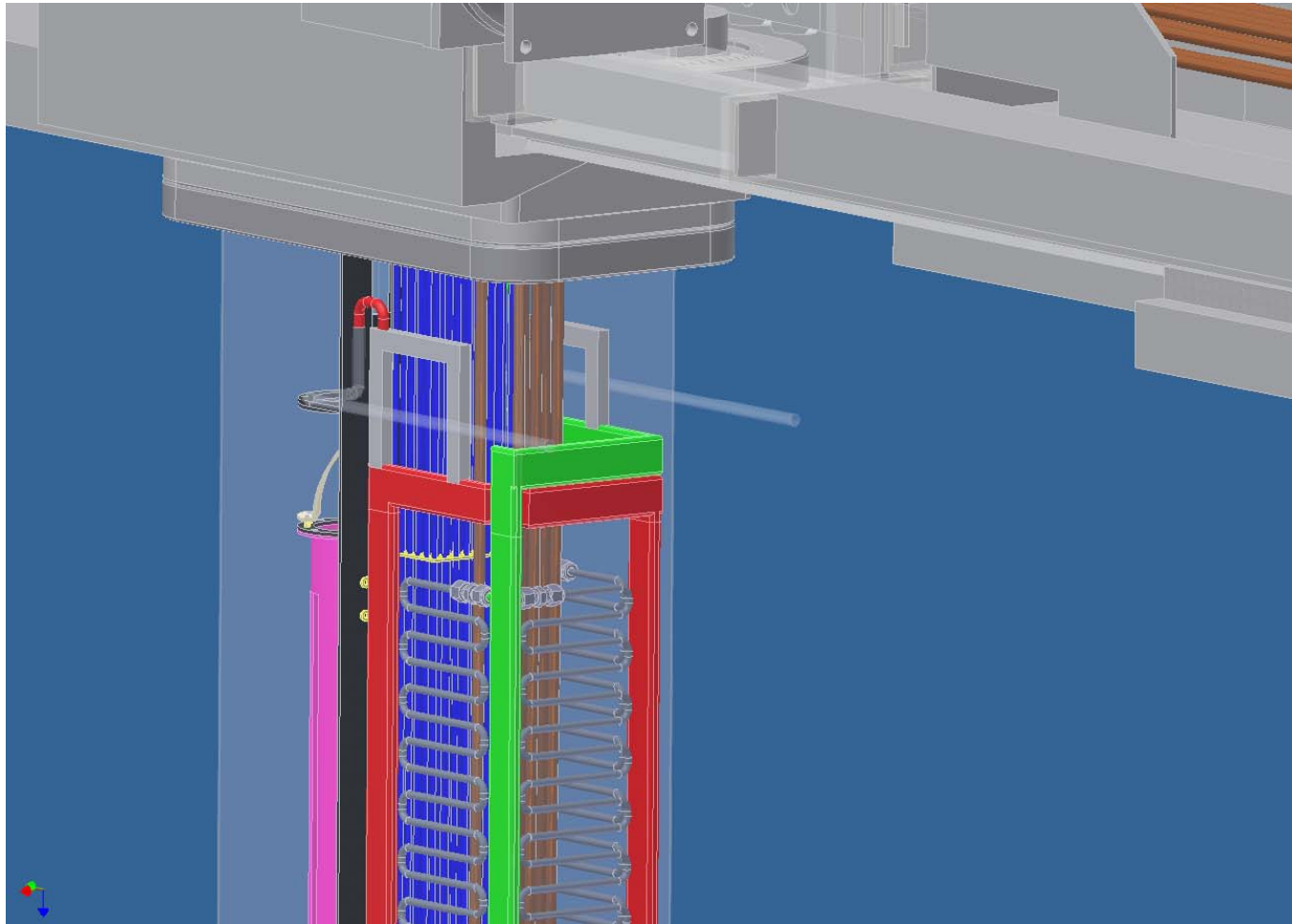



Fission target exchange procedure

1. Disconnect air connectors (electricity + water)
2. Move mobile tube above a fixed tube using the crane
3. Vacuum tide fixing of mobile tube on top of a fixed tube
4. Pump out air inside mobile tube
5. Open gate valve on mobile tube and continue to pump
6. Lower the catcher inside mobile tube, catch the target and pull it
7. Close gate valves on mobile and fixed tubes
8. Disconnect mobile tube => **some contaminated volume is open to air**
9. Move the mobile tube on top of a hot-cell
10. Break vacuum in mobile tube
11. Open gate valve on mobile tube and hot-cell entrance
12. Lower the fission target in hot-cell
13. Disconnect with telemanipulators spent target
14. Move spent target in storage area
15. Bring new target in hot-cell and install it
16. Pull new target inside mobile tube
17. Close the gate valve and hot-cell entrance
18. Disconnect the mobile tube => **some contaminated volume is open to air**
19. Move and fix mobile tube on top of a fixed tube
20. Pump air, open valves and lower the target in working position
21. Break vacuum in mobile tube (air could enter inside fixed tube.

Problem if cryopanel are colled

down)

22. Disconnect mobile tube => **some contaminated volume is open to air**

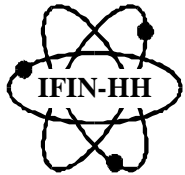

TODO - List to be discussed



- **Add reflector (and moderator?) with cooling**
- **Integration of ion-source: IRENA? ECR? or just foreseen space and feedings**
- **Add cooling of feeding bars and insulators of extraction**
- **Two stages of cryopanel liquid-N closer to target and liquid-He farther inside mobile**
- **Add a mobile hat for connectors in the air: see points 8, 18 and 22 on previous slide (Think to change laser window. Is it needed ?)**
- **Find solution not to warm cryopanel at each charge exchange (see point 21)**
- **Work out some details related to “in hot-cell” manipulation (see points 12-15)**
- **Add pump on mobile tube**
- **Optimize target exchange hall and surrounding areas (think to power supplies on high-voltage platforms, 2nd circuit for water + heat exchanger, cabling, etc)**