

Memo to Van Graves  
 From: Peter Titus  
 Subject: Magnetic loads on Mercury Jet Components (Rev 2)  
 Date: August 10 2005

An iron cylinder of .6 m length, an inner radius of .1 m and thickness of .05 m was used to model the inventory of magnetic material in the mercury jet system. Initially, the cylinder edge was placed at .5 m from the end of the magnet or 1 m from the centerline of the magnet. The iron modeled, weighs 416 lbs. The magnetic force developed was 57438N or 12900lbs. This would probably be unacceptable for the magnet cold mass supports even if the cylinder could be adequately supported. The air gap between iron cylinder and magnet was then varied from .5 to 2.3m in steps of .6m by introducing a series of 4 materials modeling the cylinder that were sequentially made either air or iron. The loads are a very strong function of this air gap. When the gap was reduced to .2 meter, the load was .4MN. One solution to the excessive loading on the iron cylinders is to increase the air gap separation between the magnet and mercury injection cylinders to a meter or more. This raises a safety concern. The large loading at a gap of 0.2m, would produce loads that would be impossible to restrain with structures we are contemplating. If these components or other iron components like gas bottles or tools are allowed near the magnet they could easily become disastrous projectiles. If you choose to control the loading via separation, we should consider some extra framing that would guarantee the mercury skid could not be positioned closer than a meter to the magnet.

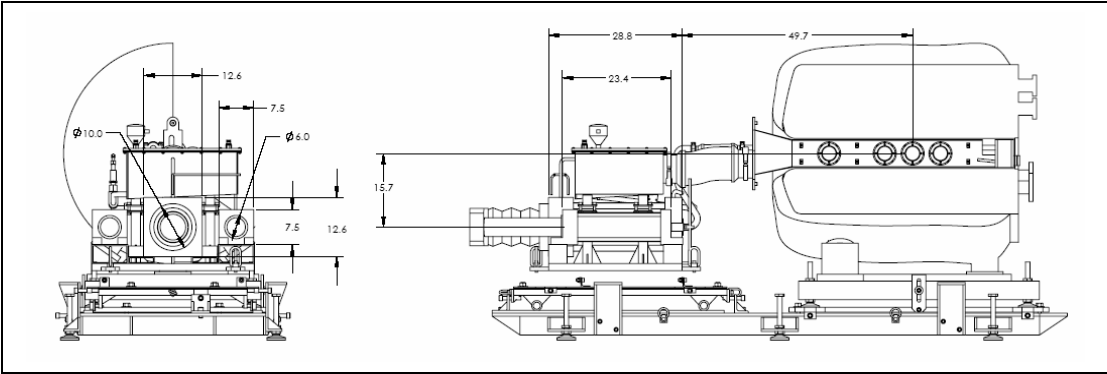

Load calculations require a non-linear magnetic solution and a path integral through the air surrounding the iron. This is done with an ANSYS macro, FOR2D. The path is defined in the graphic user interface.

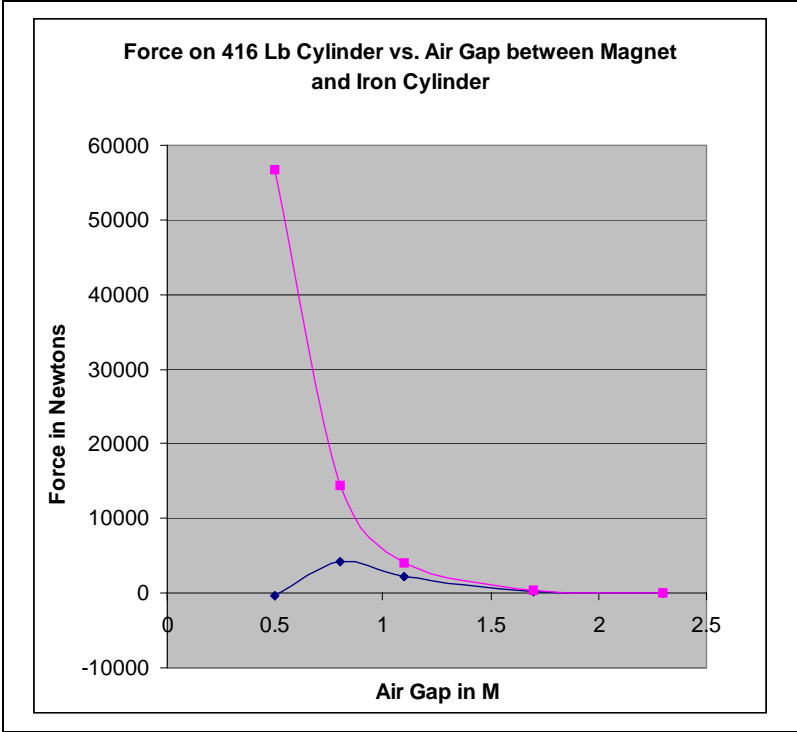
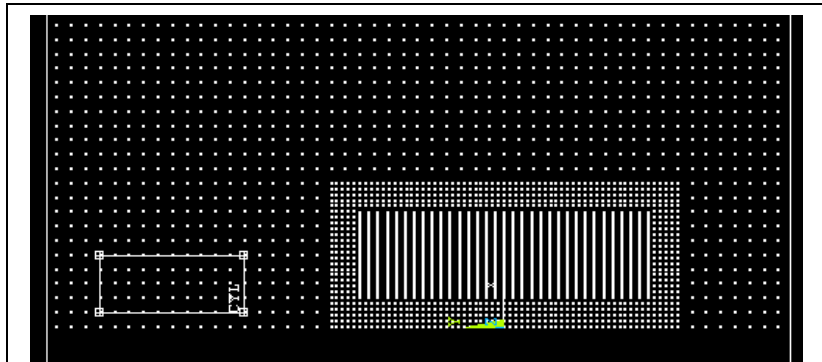

Typical Path used in the FOR2D macro

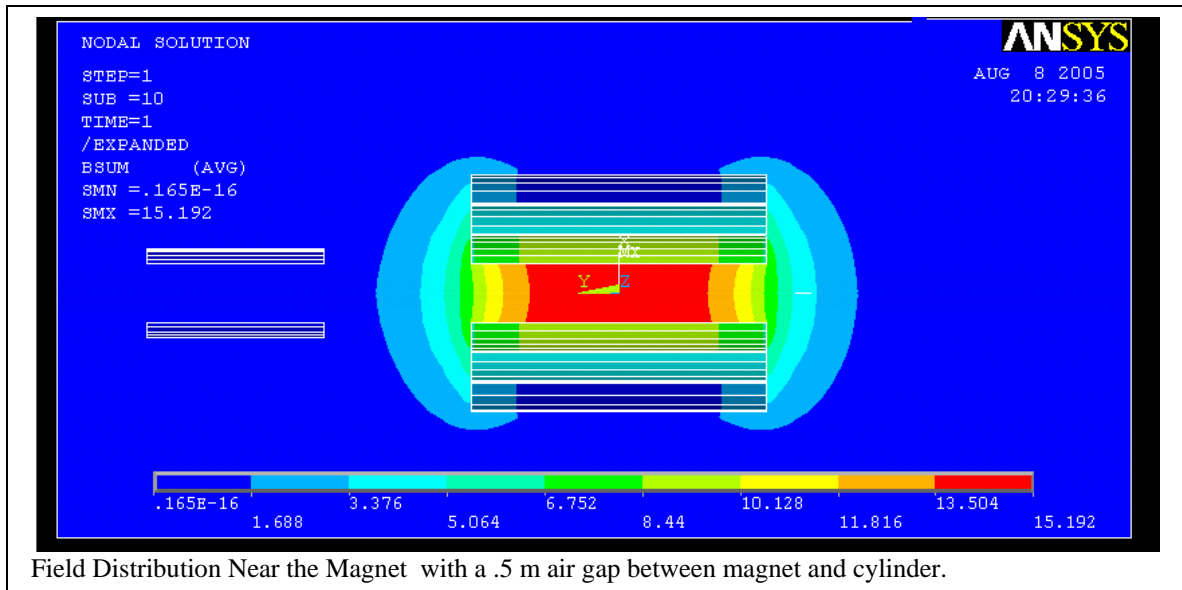

Field Distribution Near the Magnet with a .5 m air gap between magnet and cylinder.

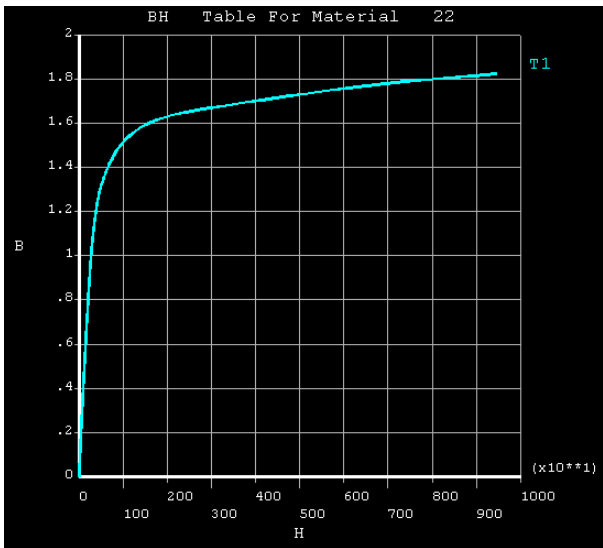

Iron B-H curve used for the cylinder

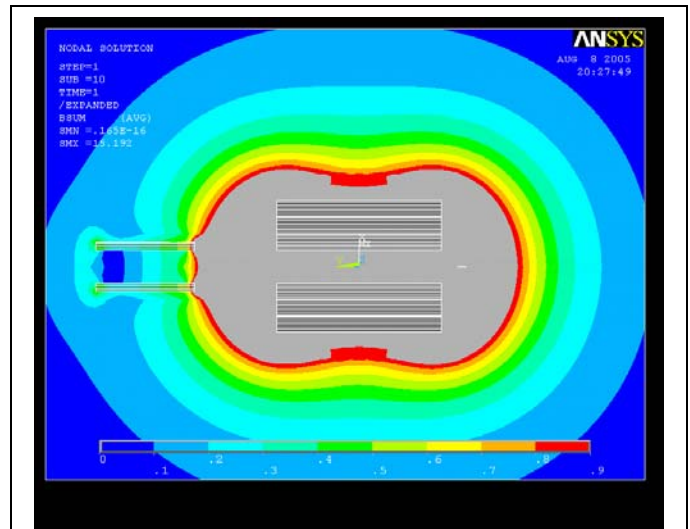

Field distribution for a .5m air gap between magnet and iron cylinder. The red contour is .9T

ANSYS output for the FOR2D Macro:

\_\_\_\_SUMMARY OF FORCE CALCULATIONS BY MAXWELL STRESS TENSOR\_\_\_\_

Force in x-direction = 1138.51061 N/m.

Force in y-direction = -57438.5828 N/m.

In this model, the x direction is radial and the y direction is axial. The N/m unit is somewhat of a mystery because the macro should compute the force integrated over  $2\pi$  and the units should be in N for an axisymmetric model. The N/m unit is probably an error in the macro. But the magnitude of the force would be similar if multiplied by the cylinder circumference.

