

Small Specimen Mechanical Property Testing at PNNL

Mychailo Toloczko, Dave Senior
Pacific Northwest National Laboratory

December, 2013



Pacific Northwest
NATIONAL LABORATORY

Proudly Operated by Battelle Since 1965

Overview of PNNL Capabilities for Small Specimen Testing

- ▶ Long history of small specimen testing in support of DOE fast reactor and fusion reactor development programs.
- ▶ Well established capabilities include:
 - ***Tensile testing***
 - ***Compression testing***
 - ***Shear punch to estimate tensile properties***
 - In-reactor creep and thermal creep
 - Density measurement to estimate void swelling
- ▶ More recently established or reestablished capabilities include:
 - ***J-integral fracture toughness***
 - Fatigue testing
 - Ring pull
 - ***Automated microhardness***



Examples of Specimens Developed During the FFTF Fast Reactor Program

► A range of specimen geometries were developed for the fast reactor program to assess:

- Tensile properties
- Fracture toughness
- Charpy response
- In-reactor creep
- Swelling
- Thermal conductivity
- Microscopy

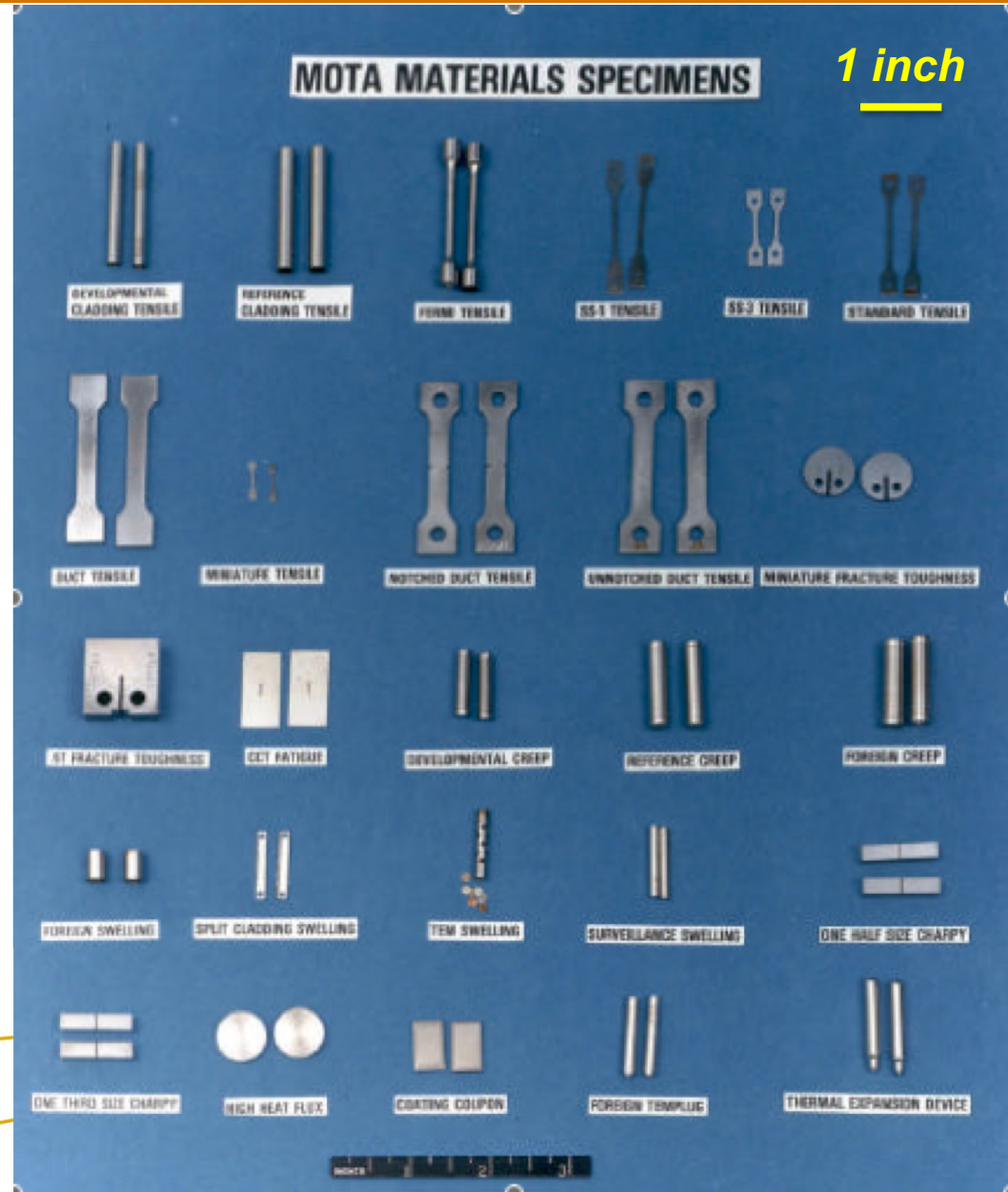

Tensile Testing of Unirradiated and Irradiated Materials

- ▶ Multiple load frames for tensile testing of unirradiated and irradiated materials.
- ▶ Air, inert gas, and vacuum up to 600°C.
- ▶ For irradiated material, use a fixture adaptable to multiple miniature specimen sizes and shapes.
- ▶ Bulk tensile properties obtained.

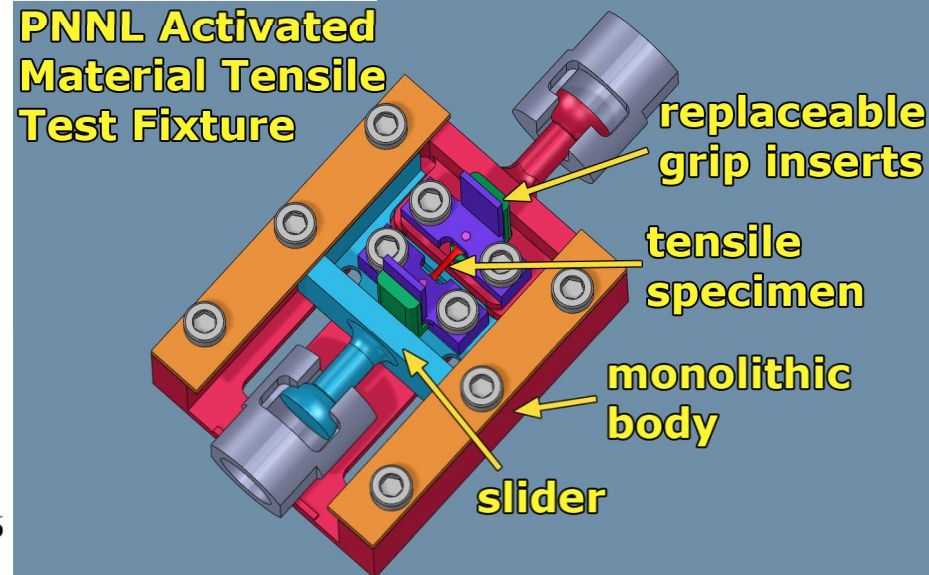
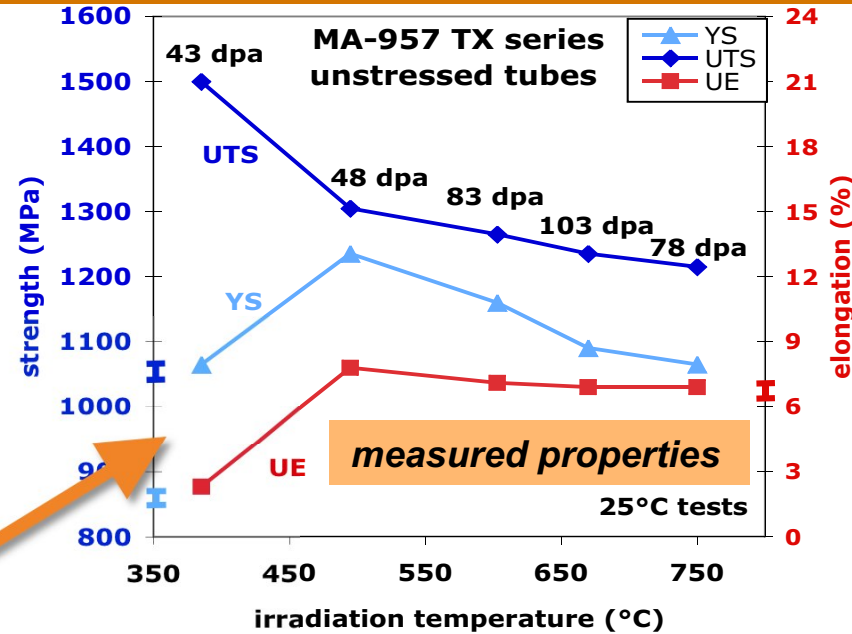
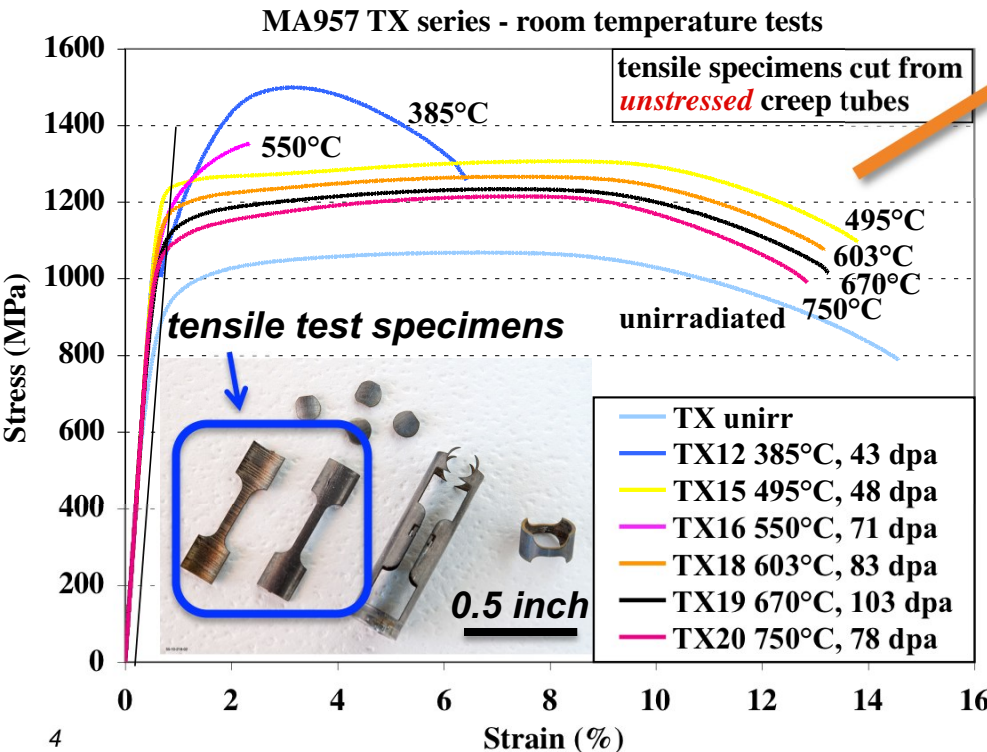

SEM Surface Examinations – Example of a Fully Ductile Failure Response

EV34 – 550°C, 113 dpa

tensile specimen fracture face

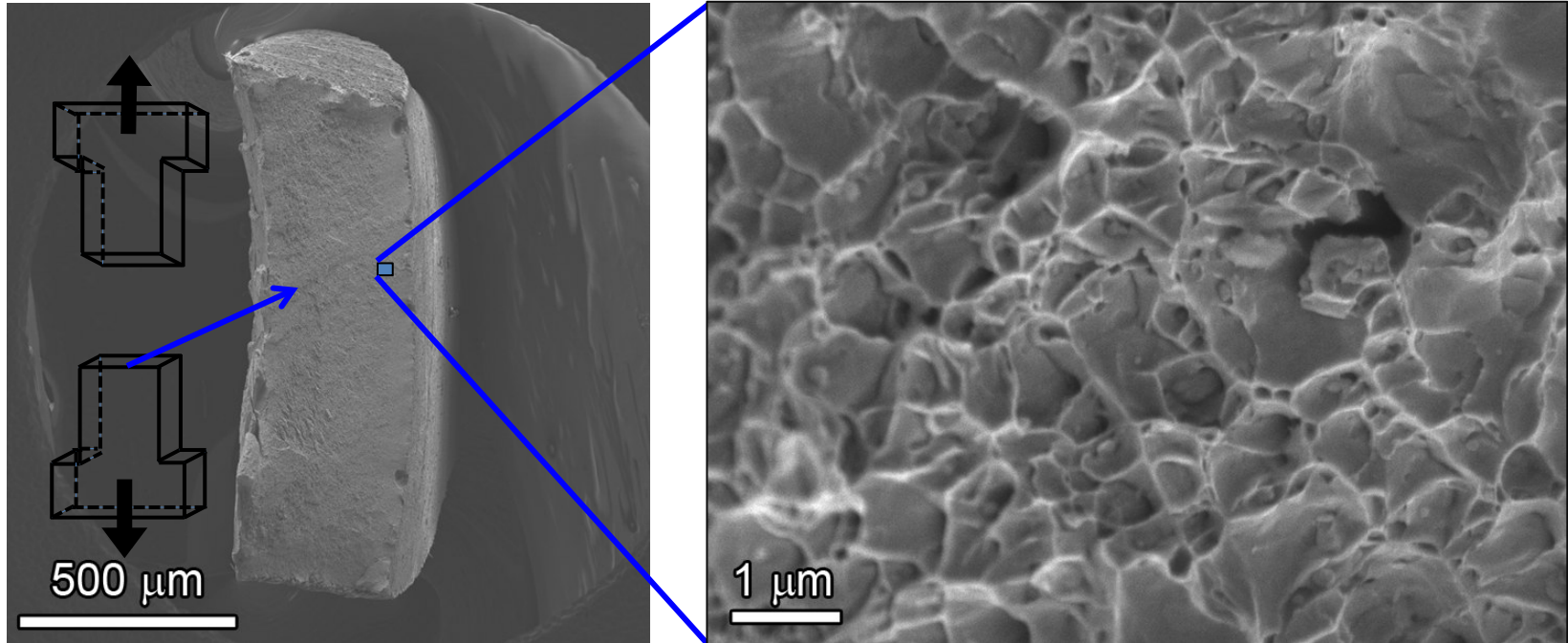

After irradiation at 550°C – 750°C to 110-121 dpa, classic ductile dimple fracture was observed.

SEM Surface Examinations – Example of a Mixed Mode Failure Response

EV46 – 412°C, 109 dpa

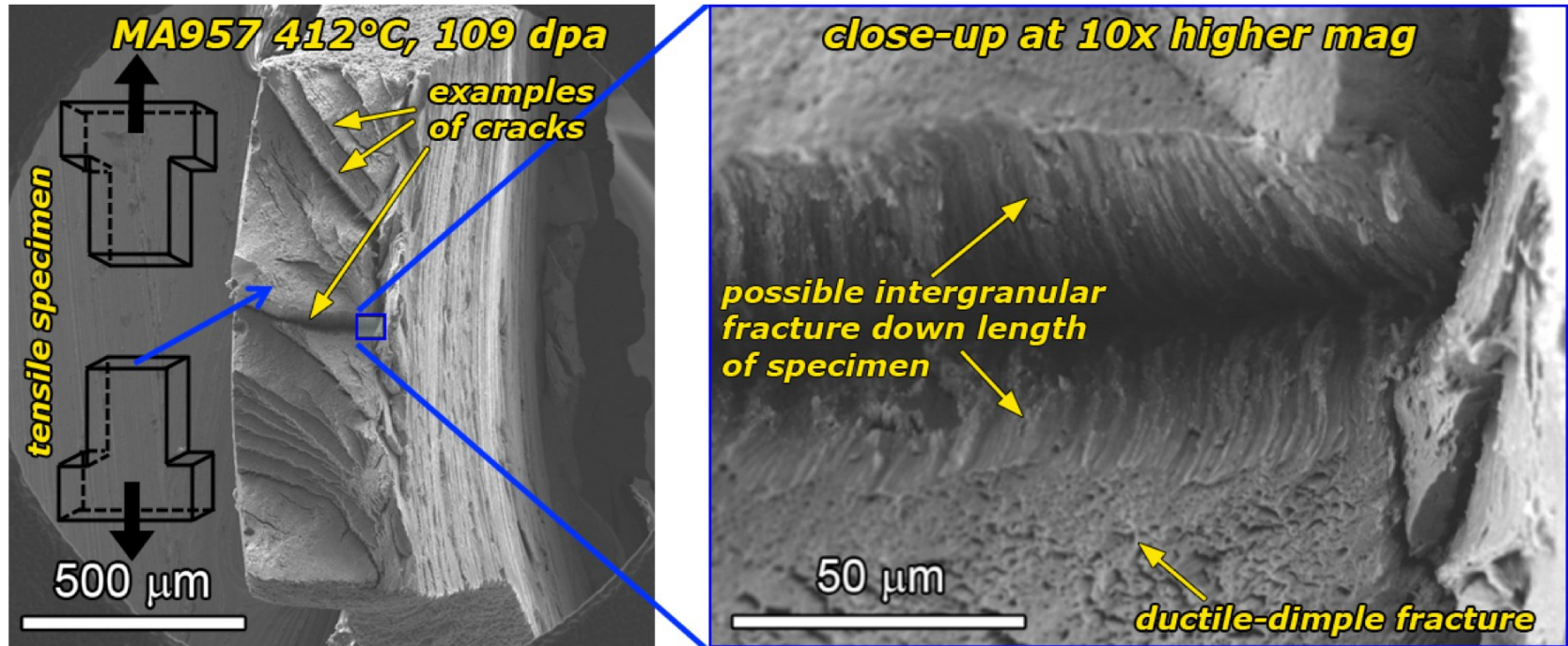

After irradiation at 412°C to 109 dpa, ductile-dimple fracture observed, but extensive splitting of the specimen along the gauge length also observed. Splitting is in the direction of the long axis of the grain boundaries. Appears to be intergranular cracking.



Pacific Northwest
NATIONAL LABORATORY

Proudly Operated by Battelle Since 1965

Fracture Toughness Testing of Unirradiated and Irradiated Materials

- ▶ Tests performed on 16 mm dia. x 2.5 mm thick compact tension specimens (slightly smaller diameter than a dime).
- ▶ State of the art system for J-integral and plane strain fracture toughness testing of irradiated and unirradiated materials up to 800°C.
- ▶ Direct current potential drop used to measure crack length in-situ.
- ▶ Fully automated precracking system.



Brittle fracture of ferritic/martensitic steel fracture toughness specimen

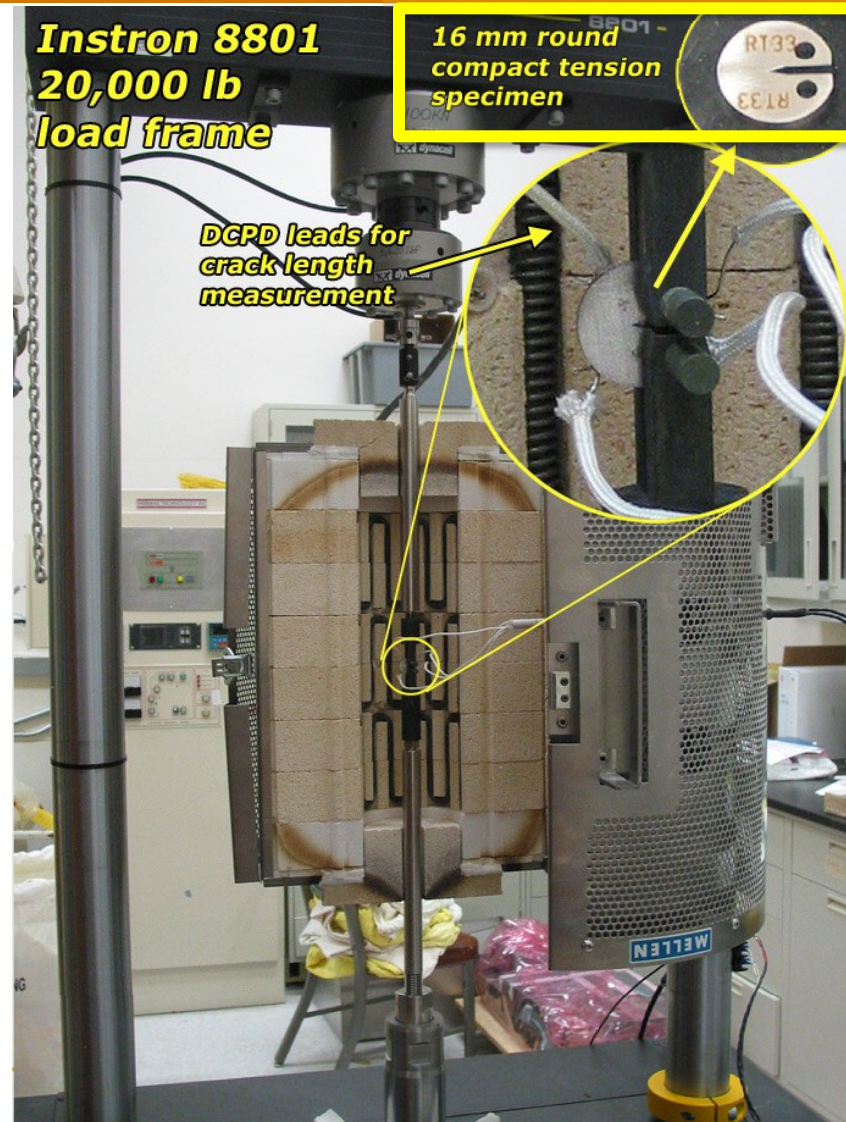

Pacific Northwest
NATIONAL LABORATORY

Proudly Operated by Battelle Since 1965

Fracture Toughness Testing of Unirradiated and Irradiated Materials

► Examples of J-integral toughness test curves of unirradiated and irradiated HT-9 tested at 25°C

- Unirradiated HT-9 shows good plasticity, stable tearing, good toughness.
- HT-9 irradiated at 375°C shows fully brittle response, very low toughness.

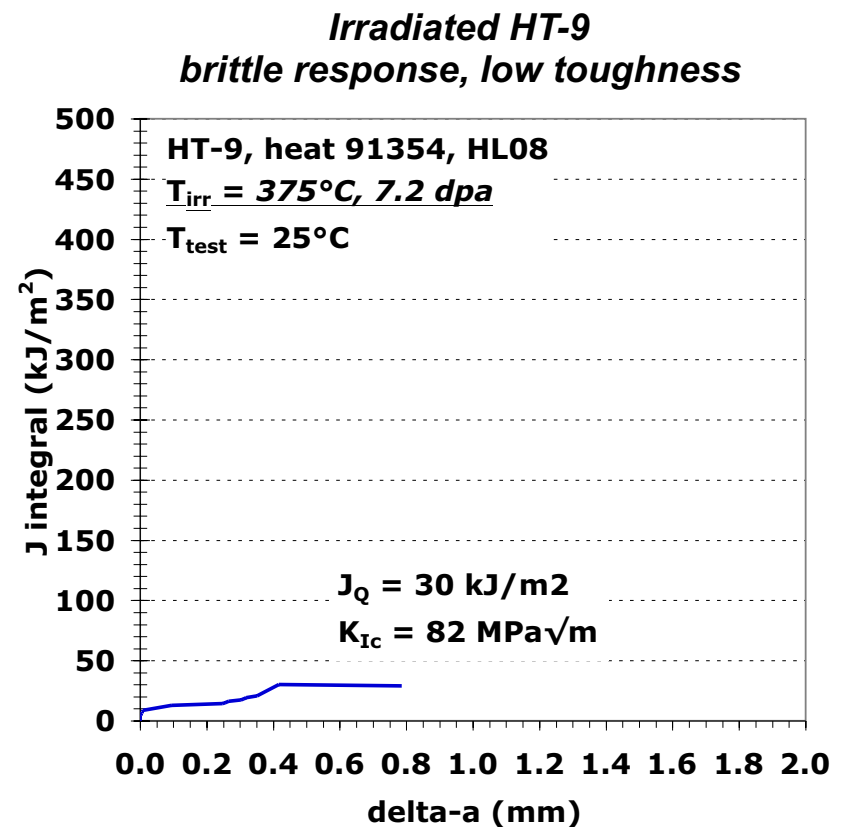
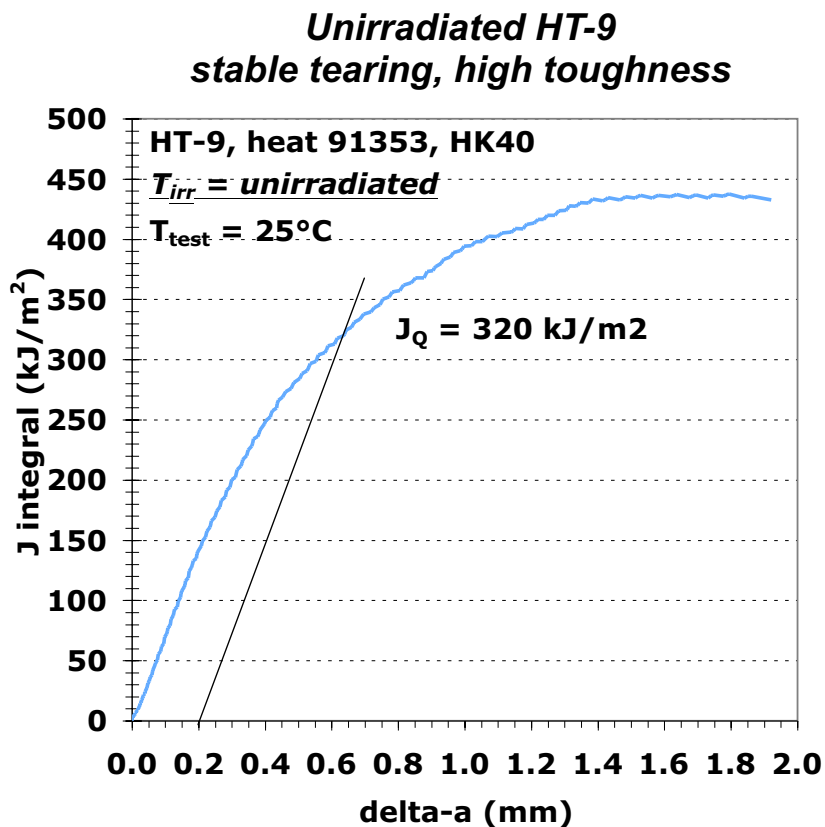

Fracture Toughness Testing – Ductile Response

- ▶ Heat 91353, $T_{irr} = 546^{\circ}\text{C}$, 105 dpa, 25°C test, $J_Q = 170 \text{ kJ/m}^2$ (unirradiated = $\sim 300 \text{ kJ/m}^2$).
- ▶ Straight precrack, stable crack extension, shear lip formation but more tearing than found in the unirradiated material.

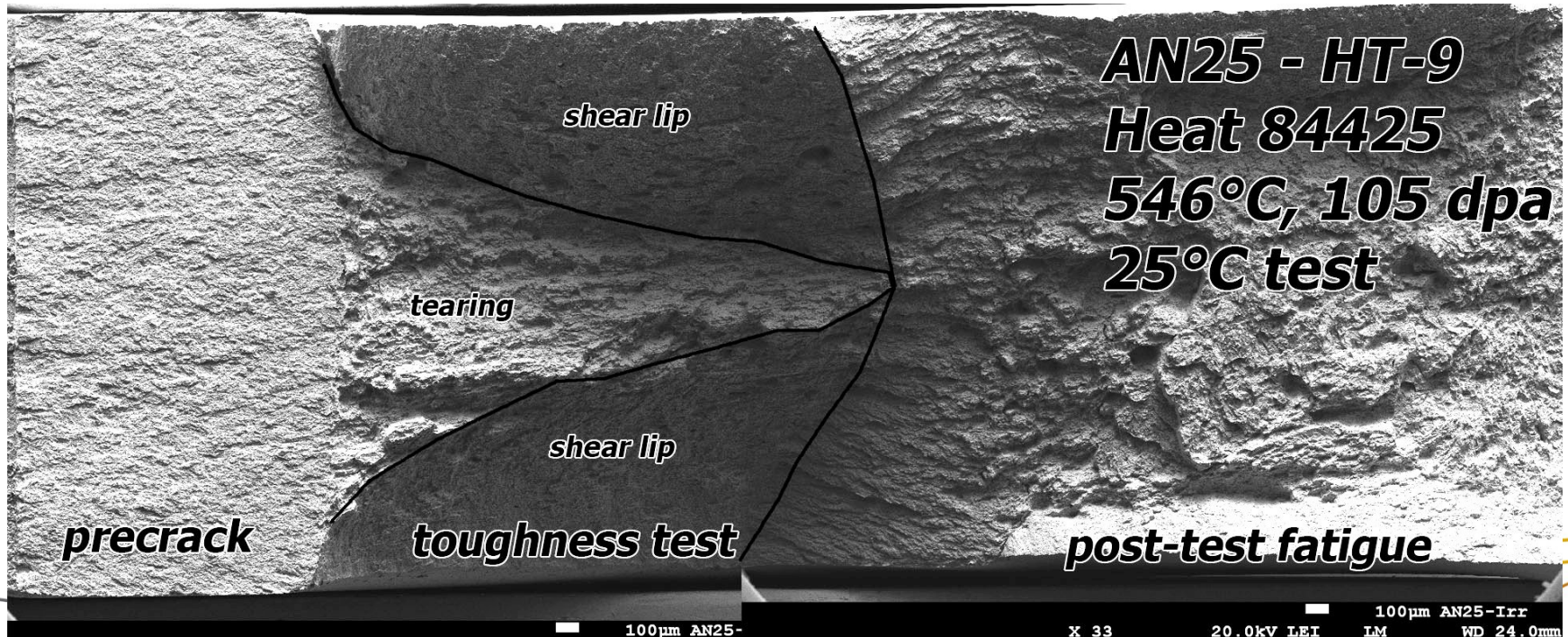

Fracture Toughness Testing – Brittle Response

- ▶ Heat 91354, $T_{irr} = 375^{\circ}\text{C}$, 7.2 dpa, 25°C test, $J_{KQ} = 7 \text{ kJ/m}^2$ (unirradiated = $\sim 300 \text{ kJ/m}^2$).
- ▶ Very straight precrack, unstable crack extension, cleavage cracking



Recent Fracture Toughness Testing of HT-9, GA3X, and F82H After Irradiation at 375°C

- ▶ The 12Cr alloy HT-9 forms alpha-prime and G-phase at 375°C that locks up dislocations and forces brittle response.
- ▶ The 9Cr alloy GA3X and the 8Cr alloy F82H are relatively unaffected by irradiation form little or no alpha prime and no G-phase. Toughness remains high after irradiation.

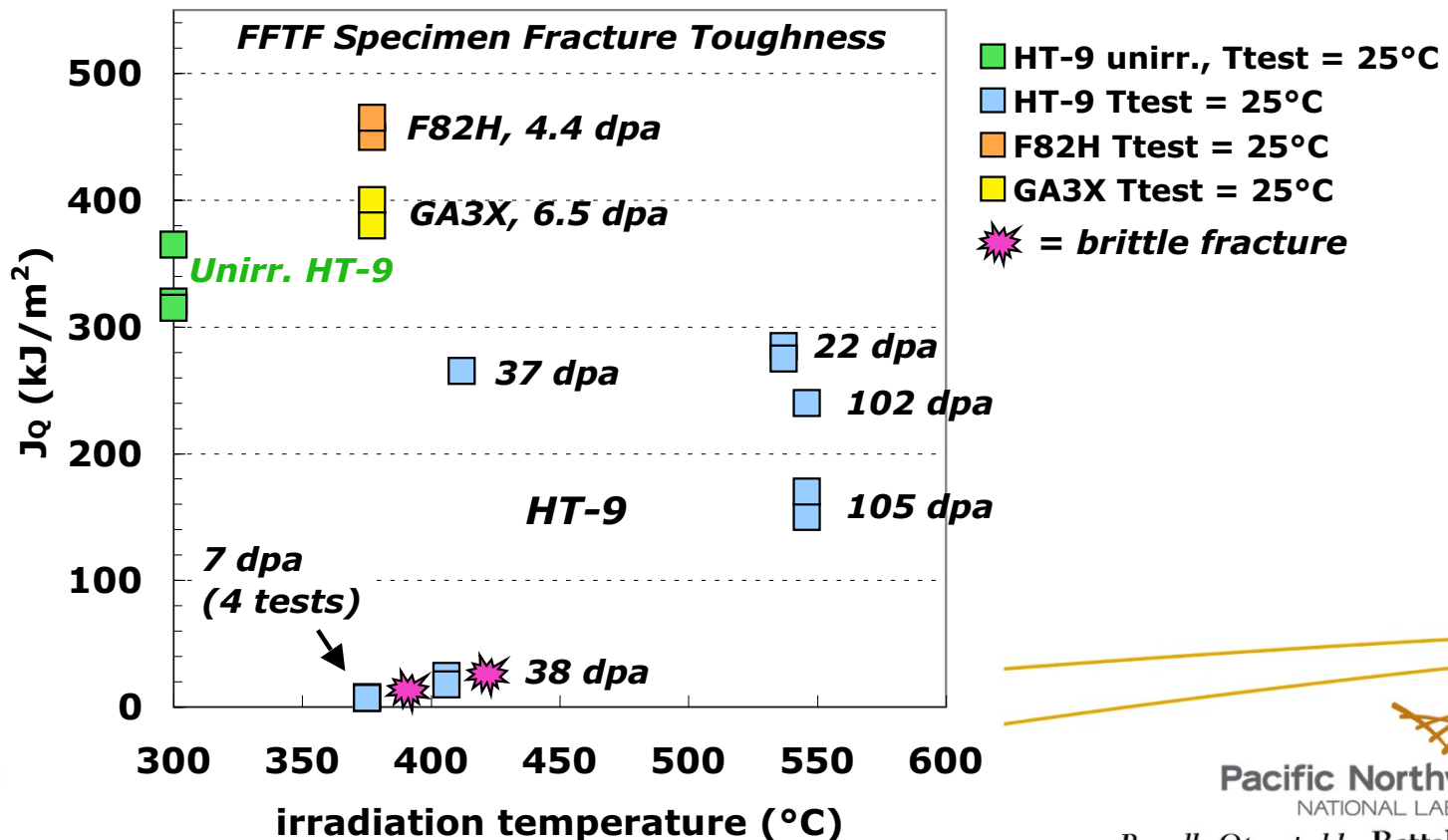

Compression Testing of Unirradiated and Irradiated Materials

Testing

- Typical specimen dimensions are 3 mm x 4 mm. Have tested 2 mm x 4 mm. 1.5 mm x 2 mm possible.
- Constructed from a high modulus WC-cobalt alloy.
- Displacement monitored with a capacitance-based displacement transducer with a resolution of better than 0.0002 mm (0.006% strain for 3.5 mm tall).
- Specimen lubricated with fine silicon carbide powder.
- Testing in air, inert gas, or light vacuum to 600°C

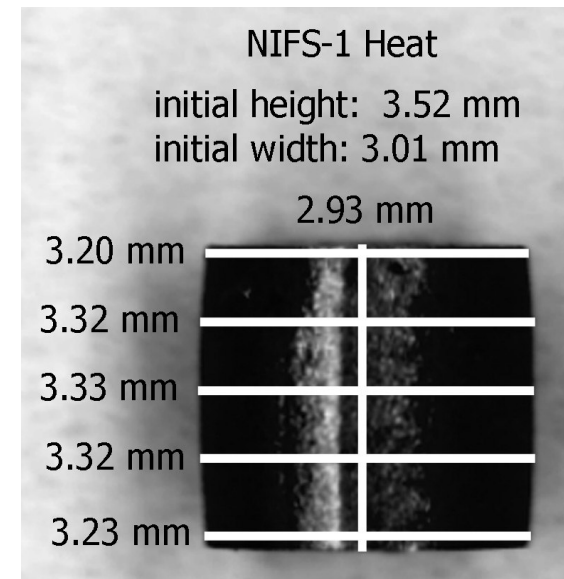

Post-test analysis

- dimensional measurements
- *0.2% offset yield stress*
- strain hardening exponent
- *microscopy*

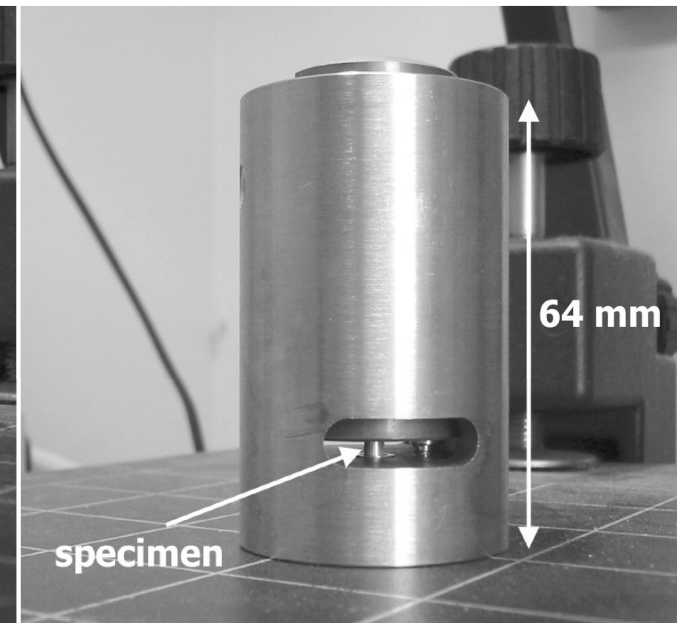
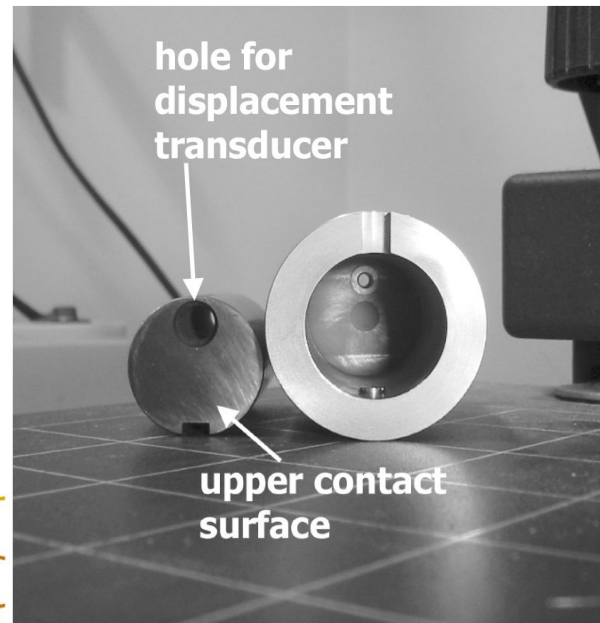

Compression Test Traces of Unirradiated V-4Cr-4Ti

► Example of unirradiated and irradiated V-4Cr-4Ti.

- Upper yield point detected in unirradiated material.
- Strain hardening response of unirradiated material has negative curvature while the irradiated material has positive curvature.

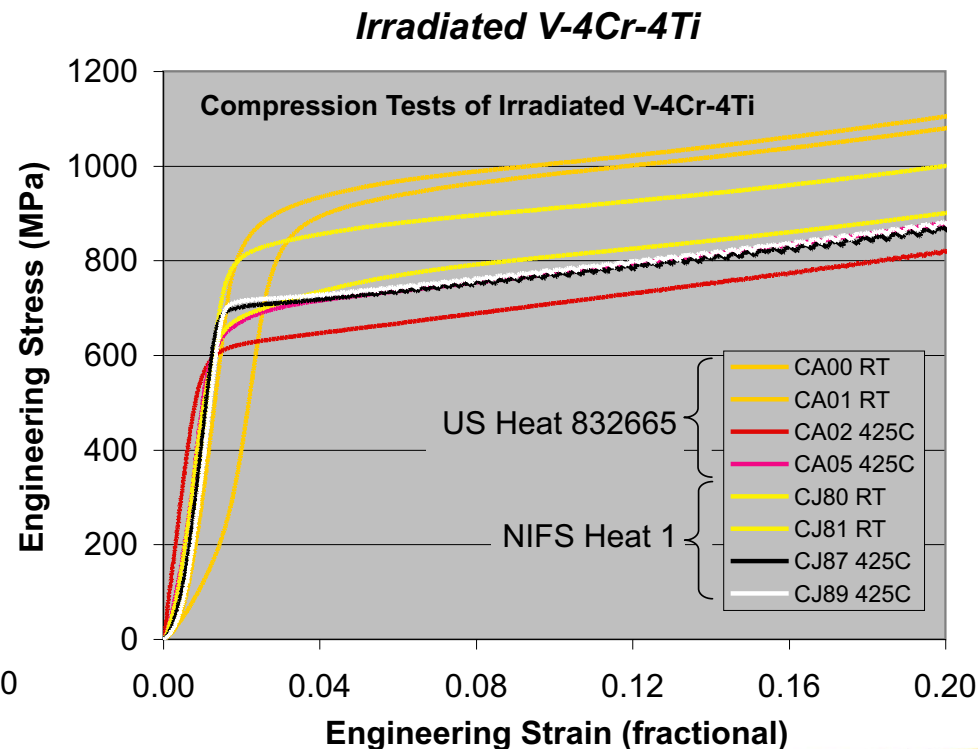
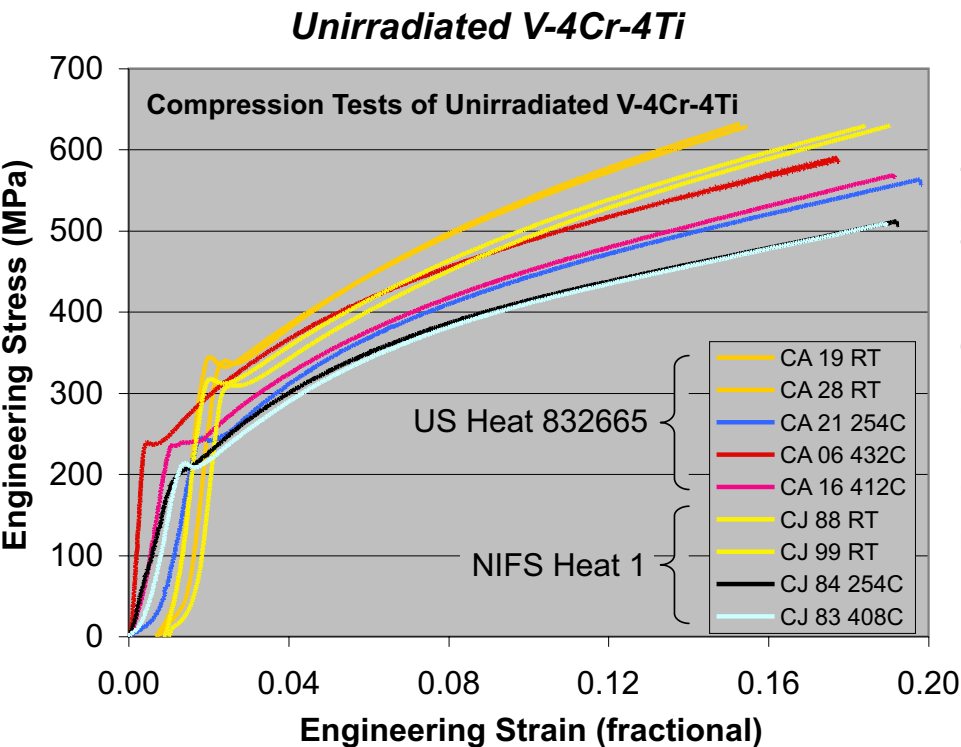

Yield Strength of V-4Cr-4Ti in Compression

- ▶ Unirradiated compression yield values are similar to uniaxial yield values taken from the open literature.
- ▶ Irradiation at 425°C to 3 dpa doubles yield strength of both alloys at room temperature and at 425°C tests.

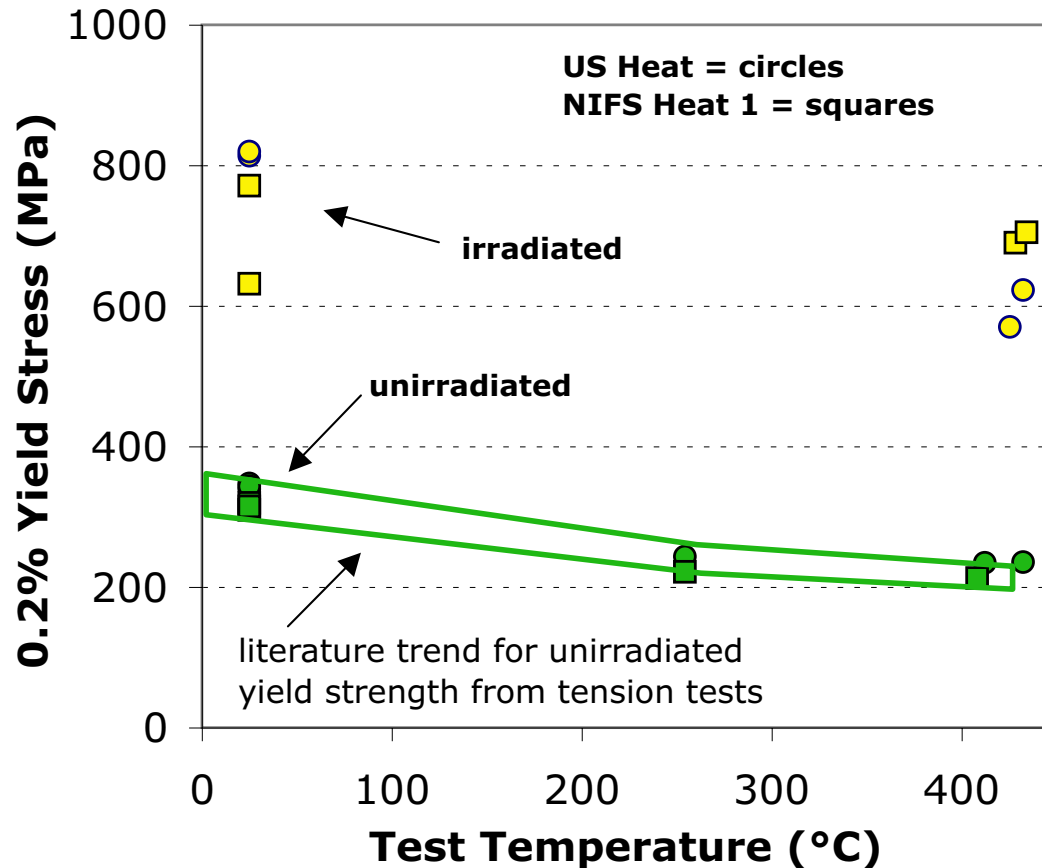

Strain Hardening Exponent of V-4Cr-4Ti in Compression

- ▶ Strain hardening exponent (n) can be used as a measure of ductility.
 - If deformation follows power law strain hardening, then the strain hardening exponent will equal the true uniform elongation.
- ▶ Strain hardening exponent from unirradiated tests compares favorably with literature trend at room temperature
- ▶ Values for irradiated specimens are lower, consistent with expectation.

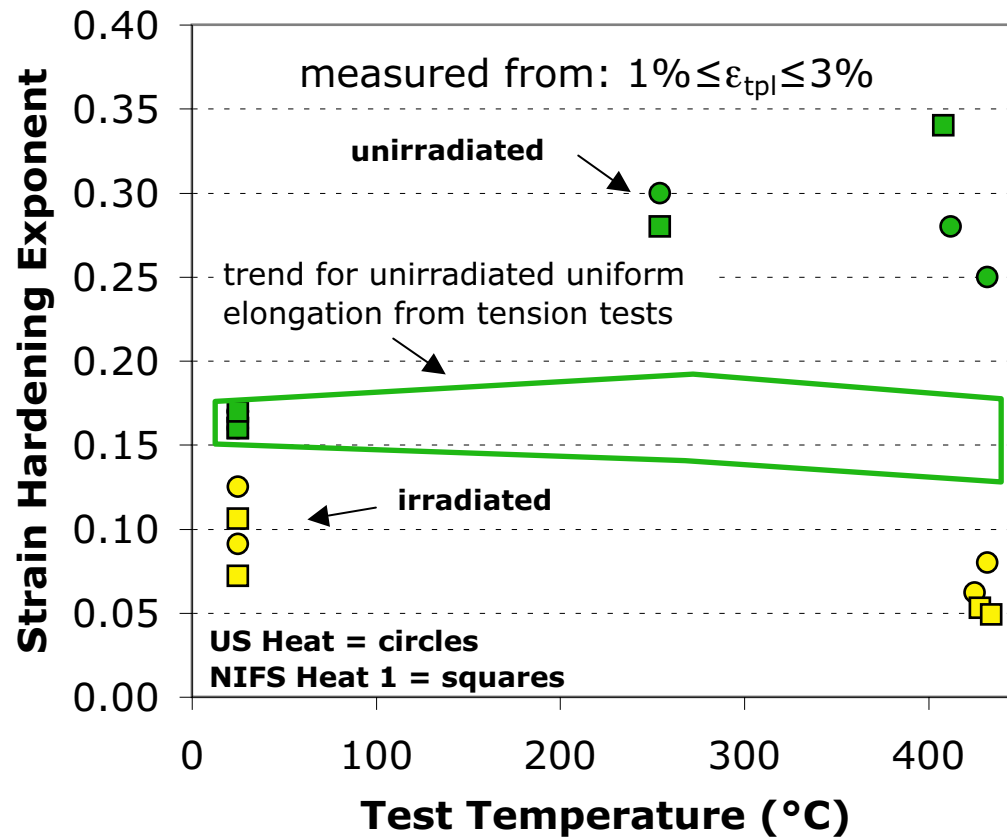

Shear Punch Testing Concept

- ▶ Estimate tensile properties from a 3 mm diameter by 0.25 mm thick TEM disk.
- ▶ A flat face punch is driven through a specimen a constant extension rate analogous to a tensile test.
- ▶ Produces a shear-like deformation in an annular region around the disk.
- ▶ Monitor load and punch displacement.
- ▶ Meant to serve as a screening test and not as a replacement for a tensile test.

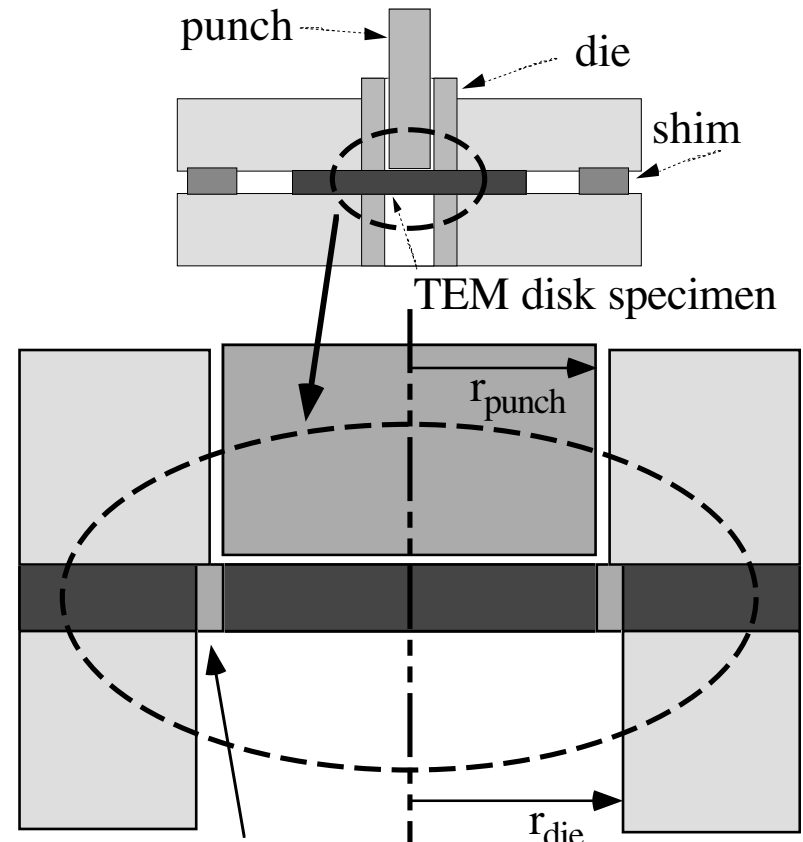

clearance between
punch and die, w

$$w = r_{\text{die}} - r_{\text{punch}}$$

$$w = 0.025 \text{ mm}$$

$$r_{\text{die}} > r_{\text{punch}}$$

$$r = \frac{r_{\text{die}} + r_{\text{punch}}}{2}$$

$$r = 0.508 \text{ mm}$$

Shear Punch Testing Concept

► Stress and strain approximations:

$$\tau_{y,m} = \frac{P_{y,m}}{2\pi r t} \quad \epsilon_{rz} = \frac{1}{2} \frac{x}{w}$$

- "P" is the load on the punch.
- "r" is the average of the punch and die radii.
- "t" is the specimen thickness.
- "w" is the width of the annular deformation region.

► Initial displacement is predominantly shear, but as the test proceeds, deformation becomes more and more ligament stretching.

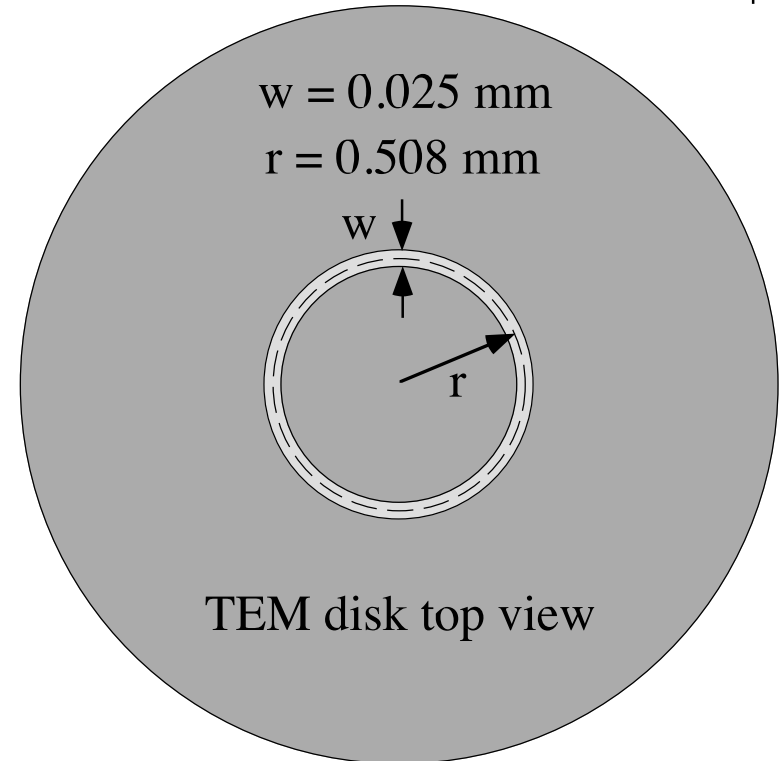
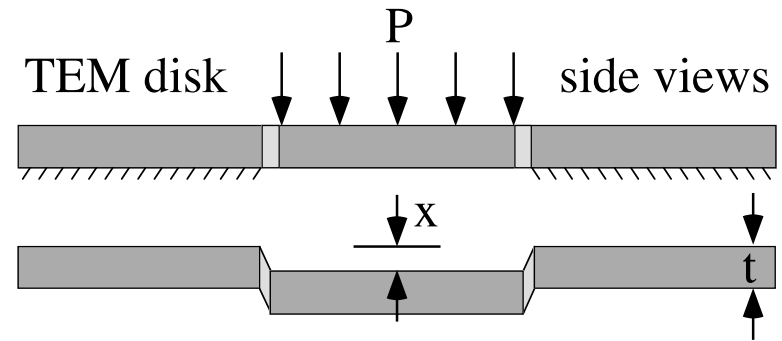

Shear Punch Testing Concept

► Some aspects of the test fixture:

- Utilizes a displacement measurement transducer that is accurate to 0.0002 mm.
- Designed to have the lowest possible compliance to region between the displacement transducer and the punch tip to provide the best possible estimate of initial shear strain.
- Punch and displacement transducer are good to 600°C.

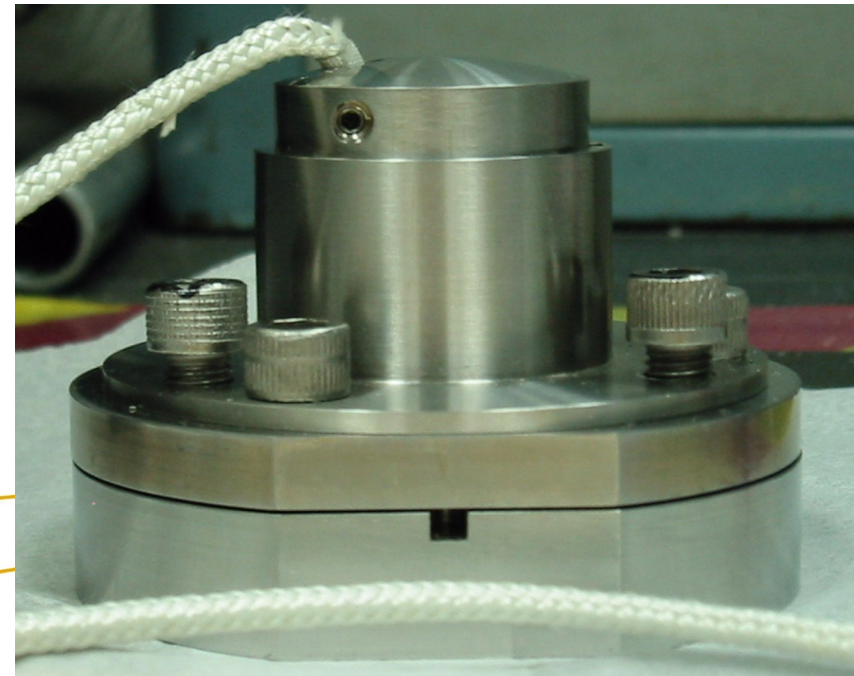
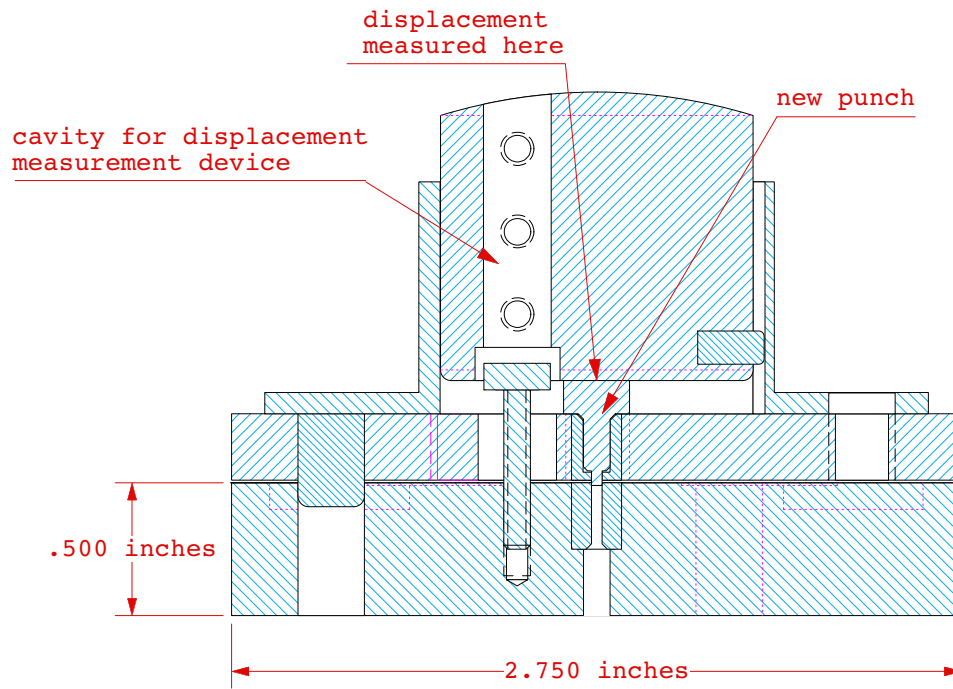

Comparative Traces: 1010 Steel (SA)

- ▶ Major features of the tensile test are reproduced in the shear punch test, in particular, the Luder's plateau is present.

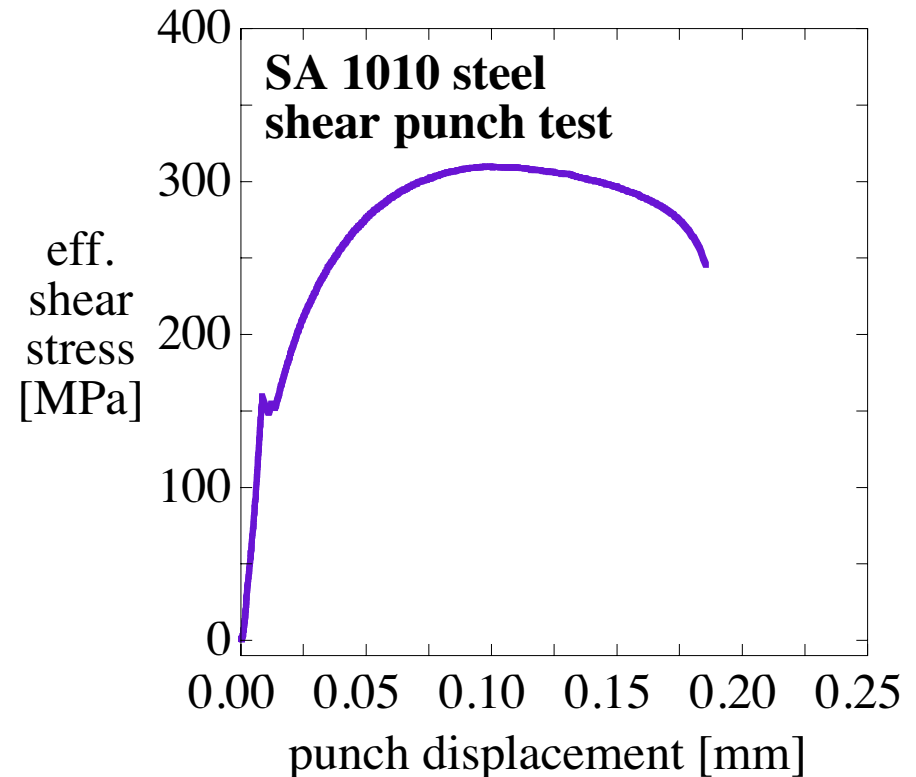
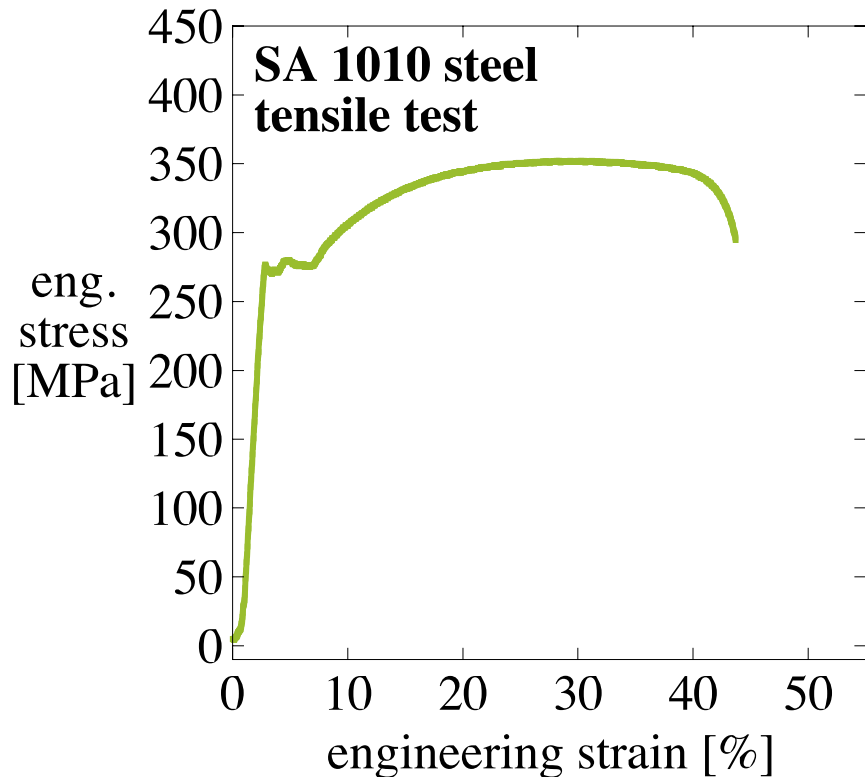

Comparative Traces: Al 5000 H38

- ▶ Major features of the tensile test are reproduced in the shear punch test, in particular
 - Strain serrations are present in both traces (although very faint in the shear punch trace).
 - Similar work hardening response.

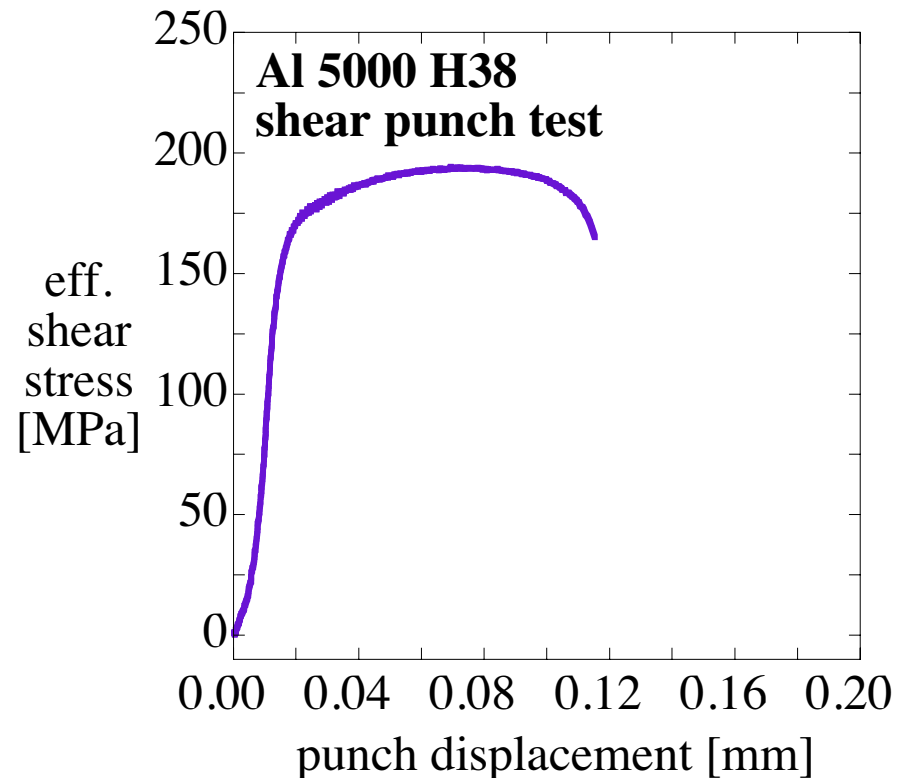
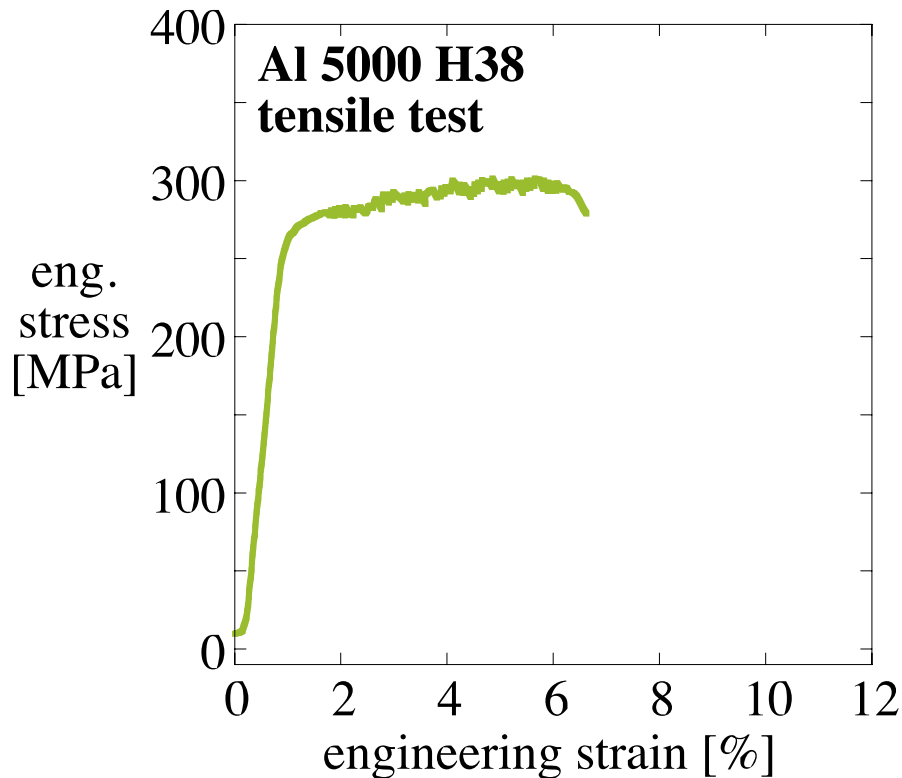

Comparative Traces: MZC3 Copper

- ▶ Similar work hardening response.

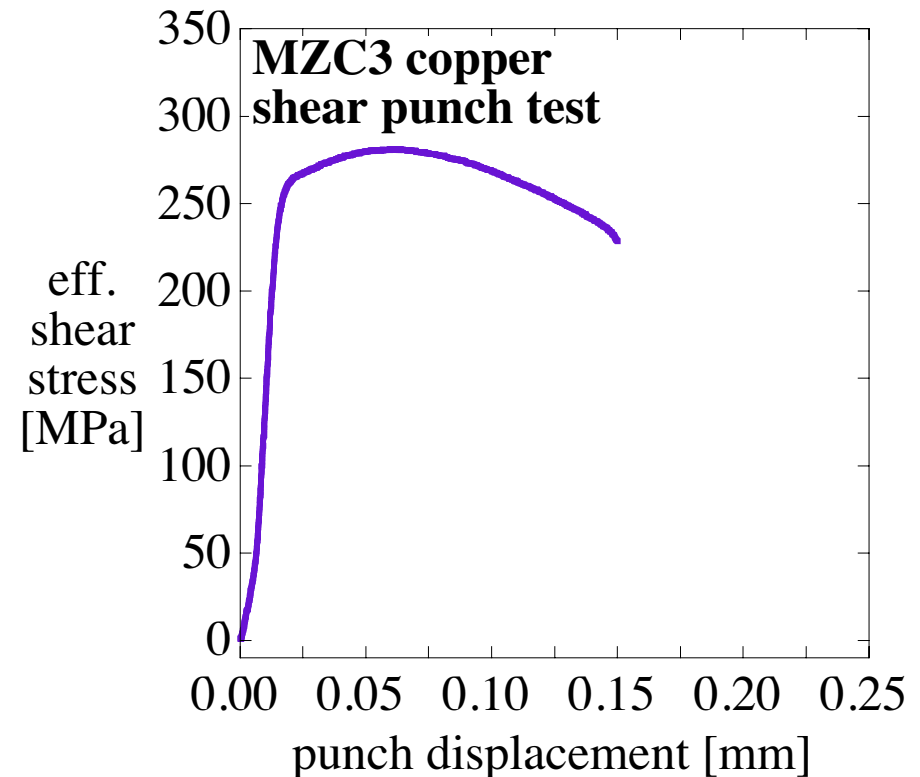
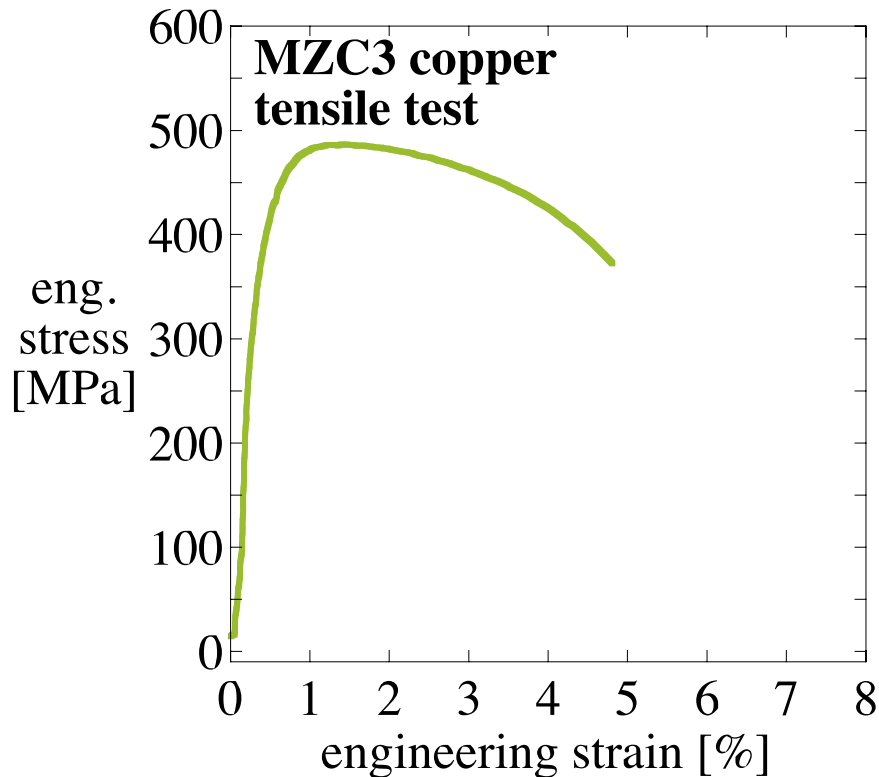

Comparison Between Tensile Yield and Shear Yield

- ▶ Shear yield obtained by measuring shear stress at 1% offset strain similar to a tensile test yield strength measurement.
- ▶ A variety of materials were tensile tested and shear punch tested at room temperature.
- ▶ Correlation slope is 1.73, matching the value predicted by the von Mises yield surface.
- ▶ Meant to serve as a screening test and not a replacement for a tensile test.

0.2% offset
tensile yield
stress
[MPa]

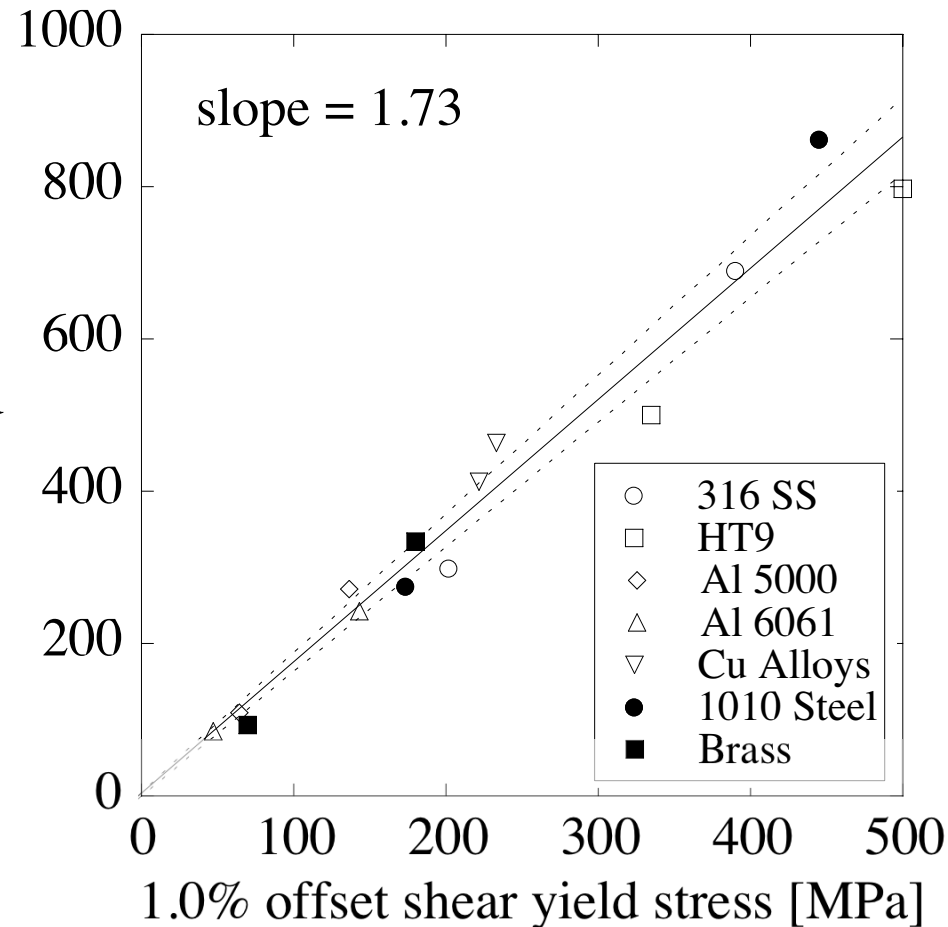

Microhardness Testing – Correlation to Tensile Properties

- ▶ It was experimentally observed in the 1950s that the stress measured at ~8% strain in a tensile test correlated roughly with $3H_v$.
- ▶ Recent work by PNNL and others have shown that $3H_v$ also correlates roughly with the 0.2% offset yield strength.
- ▶ Provides another quick screening test for yield strength.
- ▶ Most accurate when building a correlation using the material of interest.

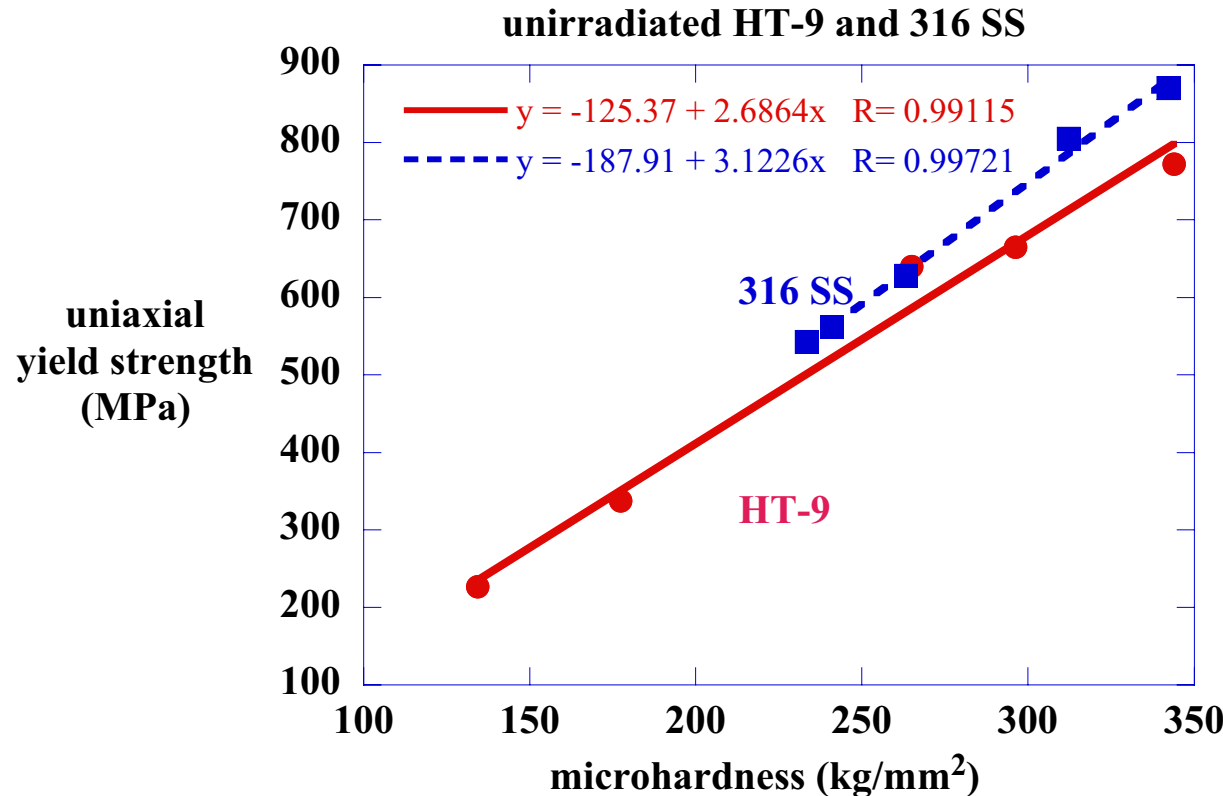

Microhardness Testing – Spatial Mapping

- ▶ Microhardness testing can also be used to map out spatial variation in tensile properties.
- ▶ In this example, microhardness has been used to identify an increase in hardness in the heat affected zone (HAZ) in a dissimilar metal weldment.
- ▶ This HAZ was found to be susceptible to stress corrosion cracking.

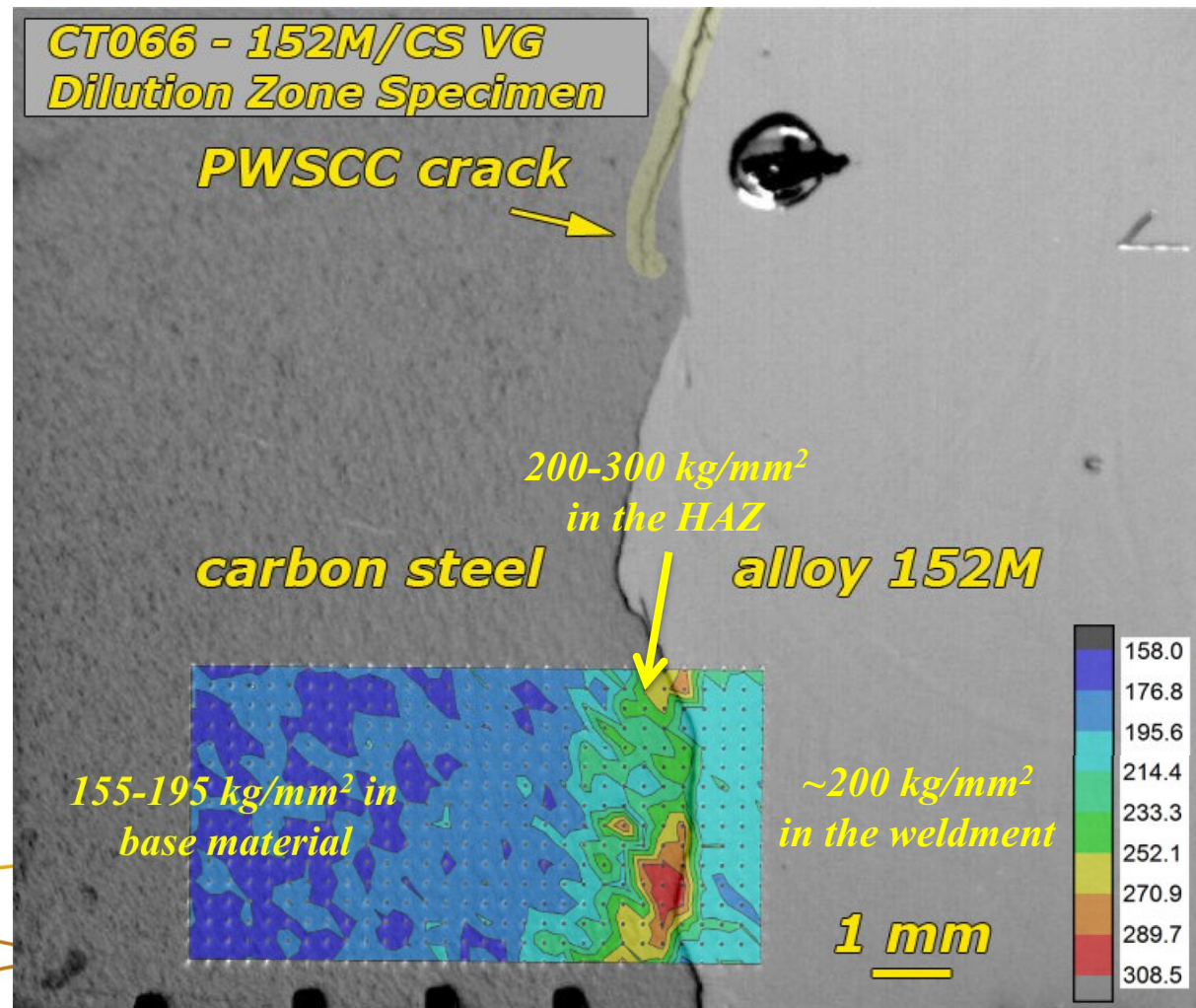

Summary

- ▶ Miniature specimen testing is mature field in the area of radiation effects on material properties.
- ▶ A wide variety of miniaturized tests have been developed and used successfully for probing the effects of irradiation on material properties.
- ▶ A large fraction of the effort has gone into estimating tensile properties from small specimens, in part because tensile properties are almost universally required for engineering.
- ▶ PNNL has one of the largest suites of miniaturized mechanical property and physical property measurements tests.

Radioactive Materials Handling Capabilities

- ▶ **Recent renovation included two new hotcells dedicated to testing of highly activated nuclear reactor structural materials.**
 - Mech1 Hotcell – Receipt, storage, cutting, and preparation for mechanical or microstructure characterization.
 - Mech2 Hotcell – Mechanical testing under a variety of environments.
- ▶ **Benchtop capabilities also exist for less highly activated materials or for very small specimen testing.**

