

# **Horn Operational Experience in K2K, MiniBoone, NuMI and CNGS**

**Ans Pardons, CERN**

**With contributions from KEK, FNAL,  
BartoszekEngineering & CERN**

# Horn operation experience

---



- **Introduction to horns**
- **Past & Present horns:**
  - Features, Failures & Lessons Learnt**
    - K2K (1999-2004)
    - Miniboone (2002-)
    - Numi (2004-)
    - CNGS (2006-)
- **Future horns: T2K**
- **Summary**

# Introduction



- **Past:**
  - K2K (KEK)
- **Present:**
  - MiniBooNE (FNAL)
  - NuMI (FNAL)
  - CNGS (CERN)
- **Future:**
  - T2K (KEK)

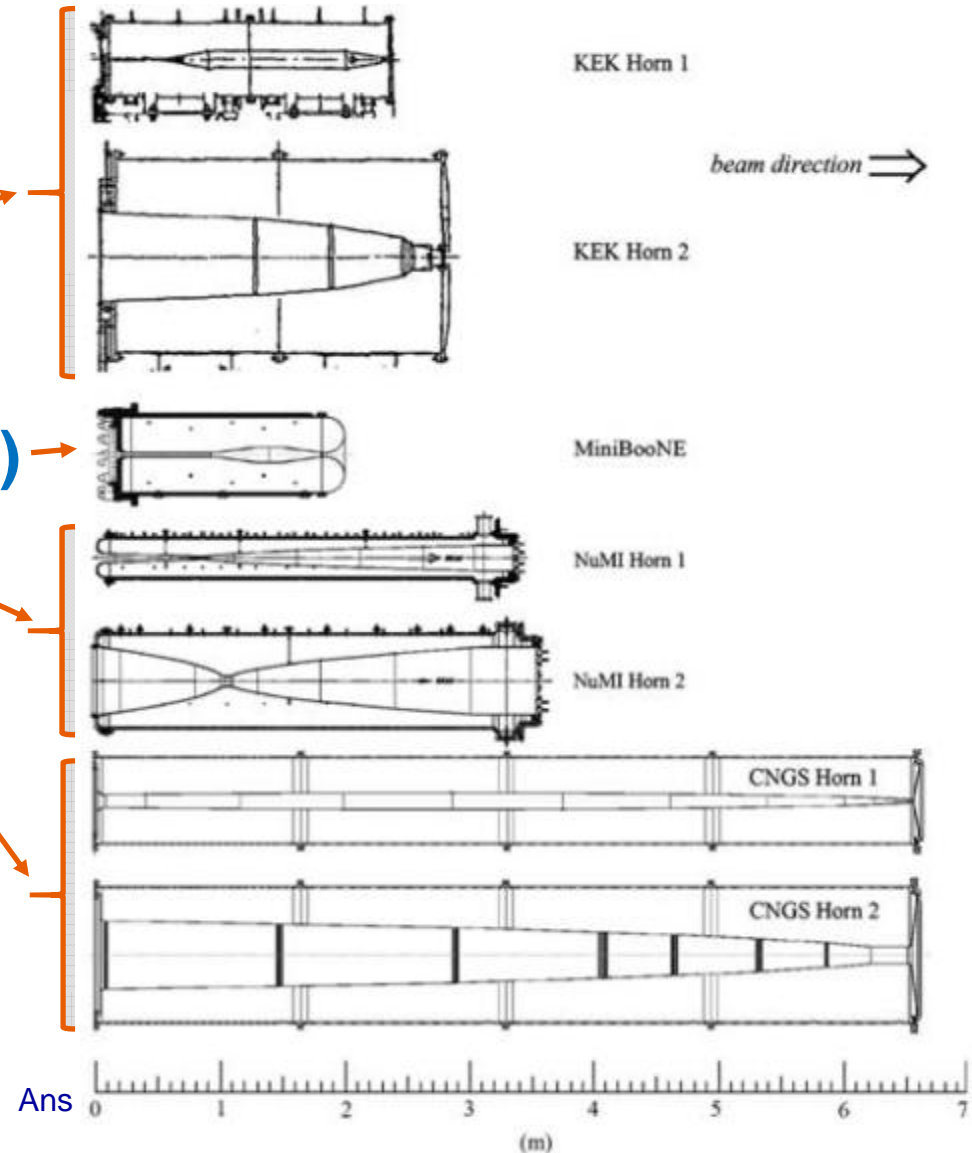

# K2K Beam Line & Horns

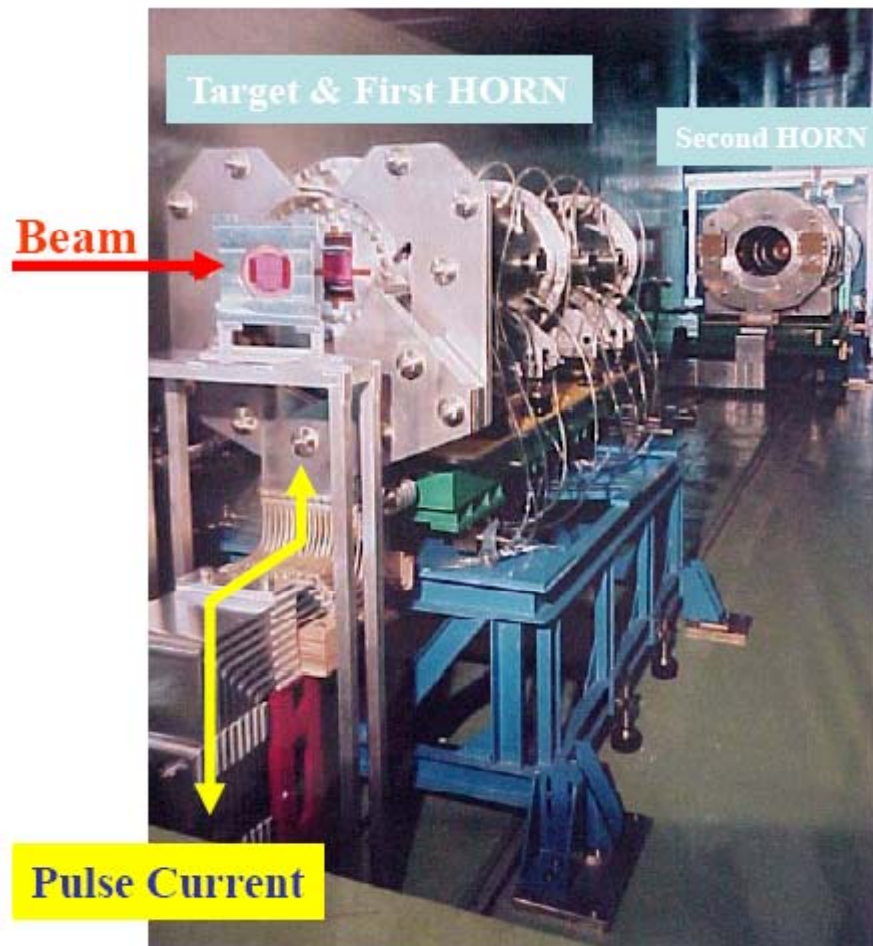

- **250kA, 0.5Hz**  
→ **Challenging (mech./elec.)**  
Yearly preventive exchange
- **12GeV / 6E12 ppp**  
→ **“accessible” (RP)**  
No time/money spent on remote handling design.  
Designed for 1E7 cycles

# K2K Horn Operation I



## 1999

- 03/'99 First beam with horns
- 04/'99 Cooling water inlet pipe leak (5E5)
- 05/'99 Stripline flexible part fails (9E5)
- 07/'99 H1: 20mm diam. Al Target rod breaks (2E6)  
→ install new H1 with 30mm target
- 10/'99 Scheduled preventive exchange of H1&H2 (3E6 & 5E6)

1<sup>st</sup> NBI workshop



Cracks in weld.  
Pipes are rigid and attached to vibrating/expanding outer conductor:  
→ stress & fatigue



Replaced by more flexible pipes.

Ans PARDONS, NuFa





# K2K Horn Operation II

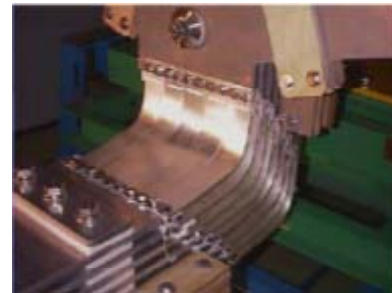

- Stripline flexible connection
- WANF: 3kA per cable
  - K2K: 6kA per cable, same geometry  
→ magnetic forces between cables x4 !  
Replaced with semi-flexible plates

## 2000-2003

Smooth runs, only interrupted by

- Stripline plate (5E6) → optimized
- Transformer cable harness (25E6, i.e. “old age”) → replaced
- Super Kamiokande incident

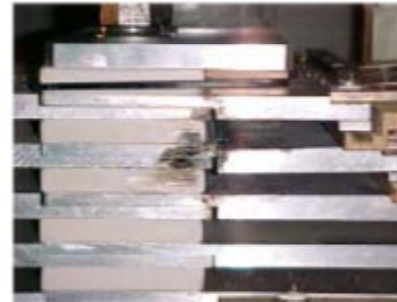

## 2004

- 08/'04 No preventive exchange because of accumulated radiation level (>25mSv)
- 11/'04 Inner conductor/target of H1 breaks (7E6)

Radiation too high for exchange & 1E20 POT reached → end of K2K

# K2K Horn Lessons



## Lessons learnt:

- We can design conductors to resist fatigue
  - Concentrate on accessory systems (electric, hydraulic):
    - Vibration (thermal expansion) can fatigue rigid water lines
    - Magnetic forces between stripline conductors are important
- Even with careful design, in-situ work reaches a RP limit
  - Future horn builders (for higher number of POT) need to:
    - Design with remote handling in mind
    - Foresee full set of spares

# MiniBoone Beam Line & Horn

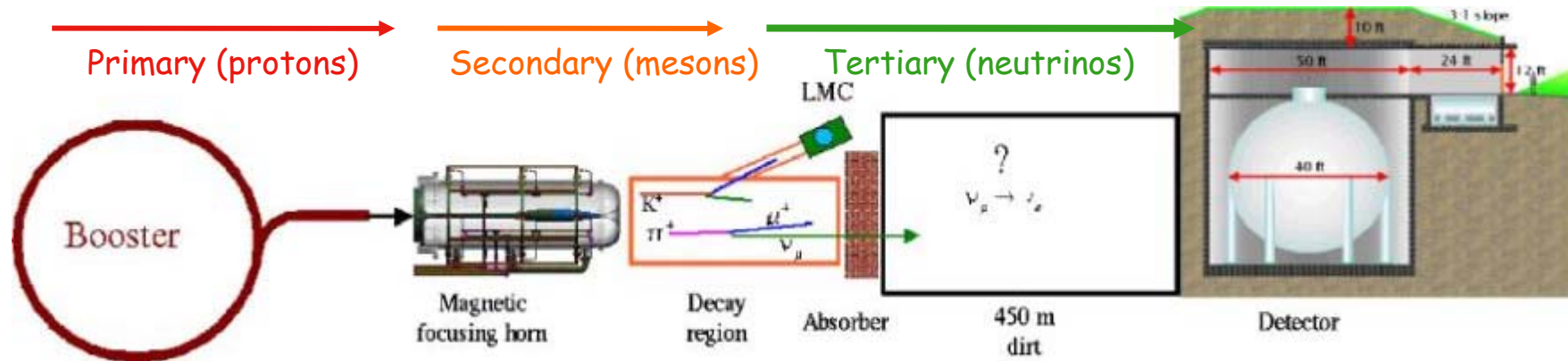

- **170kA, 5Hz**  
 → **Needs high reliability!**
  - Horn designed to 97.5% conf. for **1E8** cycles
  - Foresee spare
  - Careful control of materials
    - No plating (except in stripline electrical contacts)
    - No anodizing of aluminium for insulation/corrosion
- **8GeV / 5E12 ppp**



# MiniBoone Horn Features



- Restatement of fatigue data (→confidence to failure limit 97.5%)
- CNC machined stripline transitions & half-shells

Learnt from K2K:

- Vibration insulated water inlets on own frame



Stripline plates with smooth transitions

04/07/2008

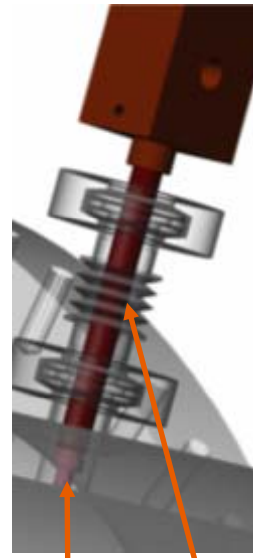

Bellows  
Sprayers

Ans PARDONS, NuFact2008

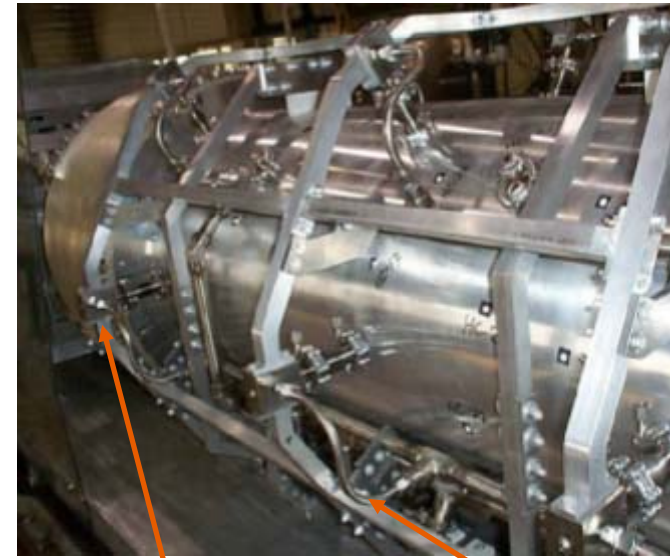

Support frame

Semi-flexible tubes

# MiniBoone Horn Operation I



- **10/'02 – end '04: smooth run**
- **03/'04: Water leak(\*) discovered**
  - **Collector & dehumidification installed, continue beam**
- **07/'04: Small ground fault**
  - **Corrosion discovered, reduce current, continue beam**
- **08/'04: Ground fault, replace horn (1E8)**
- **11/'04: Beam starts with enhanced horn**
- **Now: still running, horn has ~1.8E8 cycles!**



## (\*)Where was the water leak?

Best guess: galvanic corrosion of an aluminium seal between two stainless flanges on the bottom left of the horn. The bellows between those flanges of the trapped water that never got exchanged and became conducting.

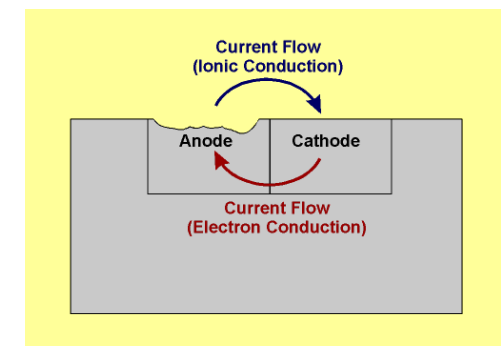

# MiniBoone Horn Operation II



L. Bartoszek, BartoszekEngineering

## Enhancing the Second Horn

- We welded the flanges on the bottom six bellows eliminating one aluminium seal
- We added an auxiliary drain to prevent water from collecting in the bottom six bellows
- The leak collection tank became a permanent part of the RAW system
- We improved the ability of the spare horn platform to route water to the leak tank
- We added a new dehumidification system to the horn box

2008: Second horn still running  
after 180 million cycles!

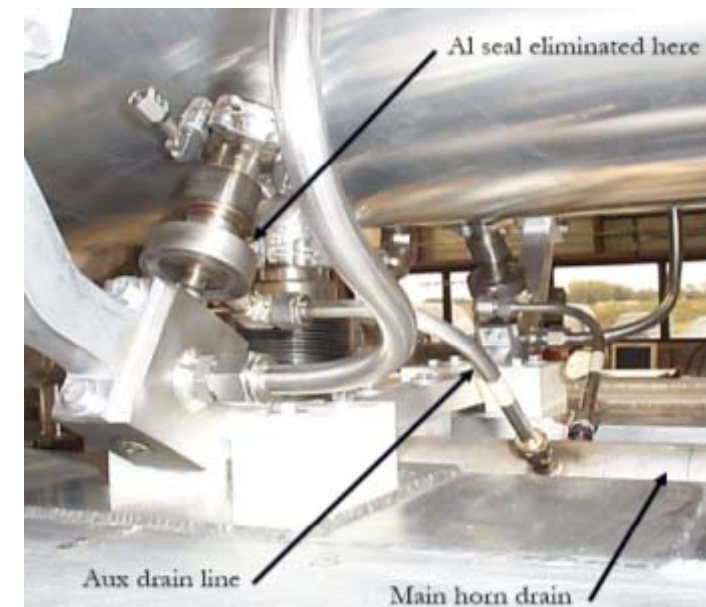
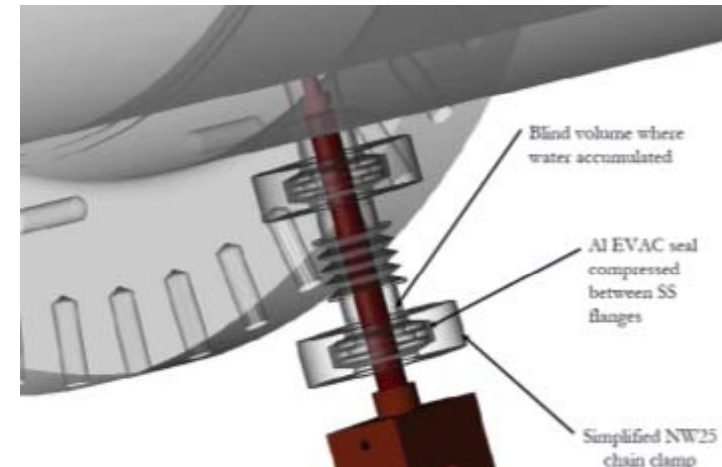

# MiniBoone Horn Operation III



2007: Borescope autopsy confirms suspicion



EVAC NW25 chain clamp at lower beam left port, covered with corrosion from water leak in Al seal.

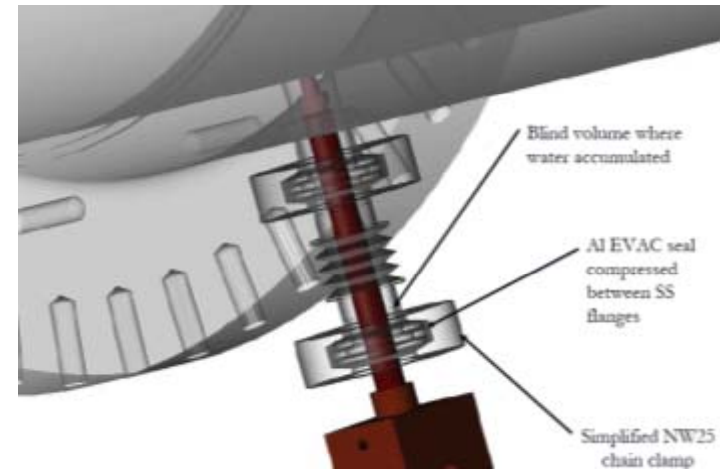

Clean clamp at upper port

# MiniBoone Horn Lessons



## Lessons learnt:

- We can design conductors to resist fatigue (beyond 1E8)  
→ Concentrate on accessory systems (hydraulic)
- Galvanic corrosion!!!
  - Avoid trapped water, foresee drainage
  - Chose adjacent materials carefully
- Investigation & understanding of failure become harder as energy/POT increase.  
→ Foresee camera, work cell facility, tools...

L. Bartoszek : If a horn is designed to survive fatigue, corrosion will probably be what kills it



# NuMI Beam Line & Horns

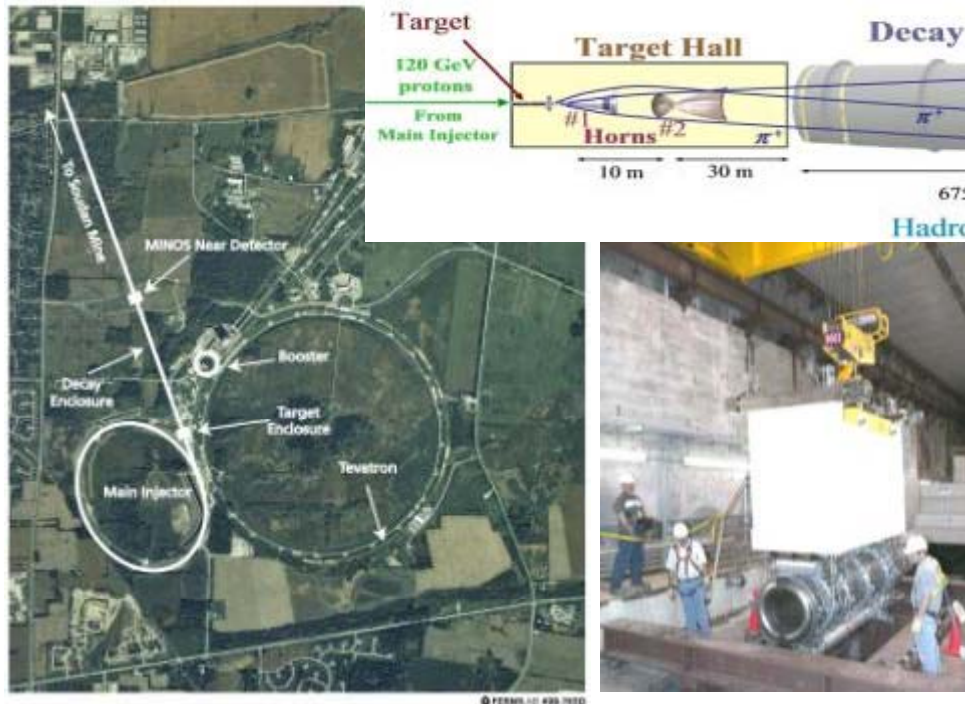

- **200kA, 0.5Hz**

→ Complete set of spares

- **120GeV / 3E13 ppp**

→ "no access"

Design: 1E7 cycles

Remote handling,

work cell built



# NuMI Horn Features



- Target & Horn 2 mobile along beam axis
- Horns hanging from support modules

Learnt from K2K (a.o.):

- Remote connections for water & current  
→ Remote exchange (rather than repair)

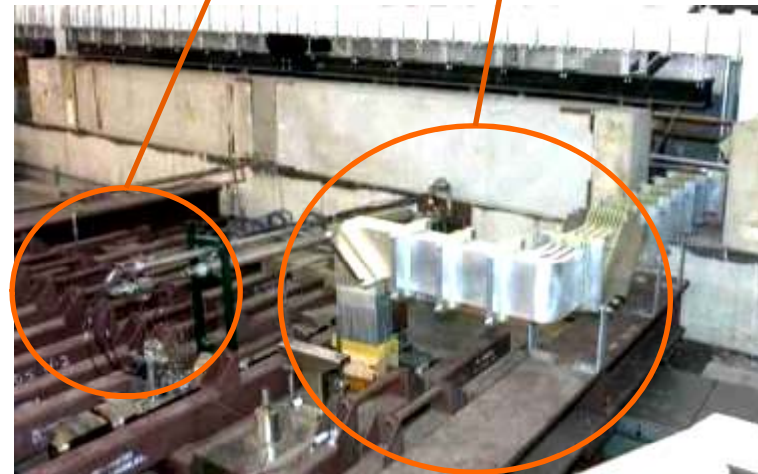
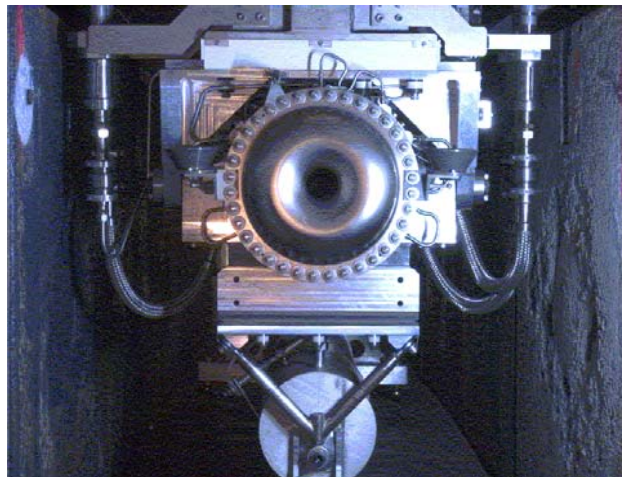

# NuMI Horn Operation I



- 01/'05 First beam with horns
- 02/'06 H2 water suction line **leak in ceramic insulator** (see next slide)
- 06/'06 H1 **water spray clog** with resin beads from de-ionization filter
- 08/'06 H1 water supply line leak in ceramic insulator
- 10/'07 H2 water suction line leak in ceramic insulator
- 02/'08 H1 water supply line leak in ceramic insulator
- 06/'08 H1 water suction line leak in ceramic insulator

(see next slide)

5 out of 11  
have failed!

(2.4E7cycles & 5E20 pot)

→ **Exchange Horn June 2008 (done: <http://www.fnal.gov/pub/today/>)**

Ejector pump (next to filter with beads) sucks water (and air) up from drain tank under horn, Check valve avoids back flow of water (and filter beads)

Valve failed at ~200h

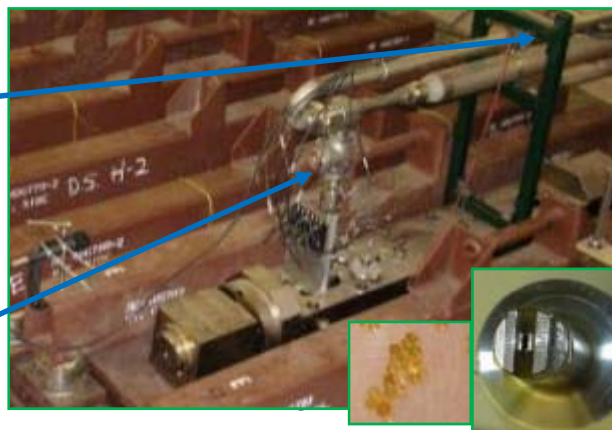

## Solution:

- "Vacuum out" the beads
- Replace check valve (new type)
- Increase ejector flow (spares valve)
- Install microphone to detect excessive valve operation



# NuMI Horn Operation II



- **Design:**
  - Commercial, Kovar-ceramic, brazed
- **Observations:**
  - Thinnest Kovar section broke (H1)
  - Corrosion pit in Kovar (H2)  
(ceramic & brazing fine!)
  - Minimum dimensions not guaranteed
- **New in-house solution:**
  - Shrink fit at 300C (no brazing)
  - Same materials, thicker pieces
- **Exchange**
  - As of 07/08: all exchanged

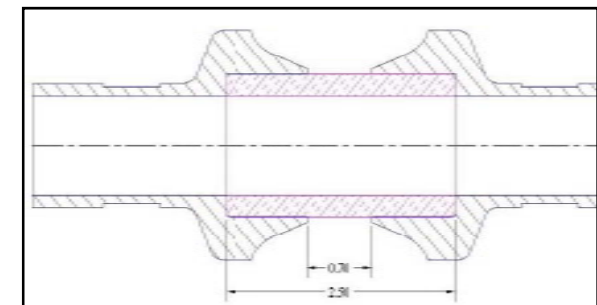
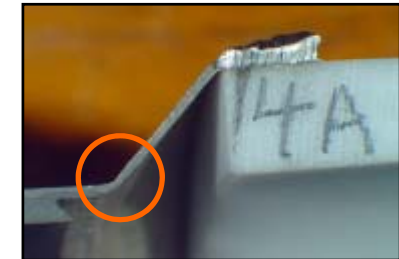

# NuMI Horn Lessons



## Lessons learnt:

(Concentrate on accessory systems)

- Insulation water lines
  - Vibration, leak tightness, pressure, brazing = stress
    - Choose solid solutions
  - Work cell extremely useful
- Radiation:
  - Each repair becomes a major operation ~months.
    - “Remote design” pays off, smooth horn handling
    - Work cell pays off, as well as tooling, training, etc.
  - Test horns & peripherals rigorously without beam
    - Some repairs are not possible (→ horn exchange)



View of Horn 1 through shielding slot



# CNGS Beam Line & Horns

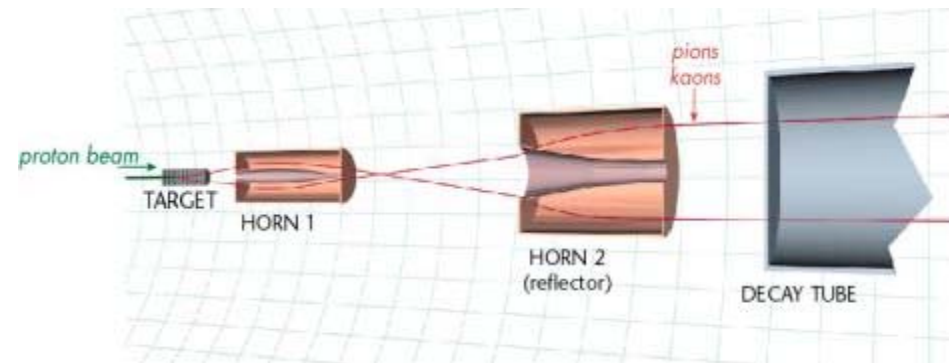

- **150/180kA, 0.3Hz** (20Hz inst.)
- **400GeV / 2.4E13 ppp (x2)**

**Design: 4E7 cycles**

- Robustness & Redundancy
  - Remote exchange
  - Spare horn
- (no spare reflector yet)**



# CNGS Horn Features



- **Cooling Circuit (supply & sprayers)**
  - In-situ spare, easy switch  
( $\ll 1\text{mSv}$  total dose after 1y beam, 1w stop)
  - Remote water connection (no leaks)
- **Remote handling & electrical connection**
  - 95% Remote exchange of horn  
( $< 1\text{mSv}$  total dose after 1y beam, 1m stop)
- **Remote & quick polarity change!**
- **15m long striplines (Horn  $\rightarrow$  Transformer)**

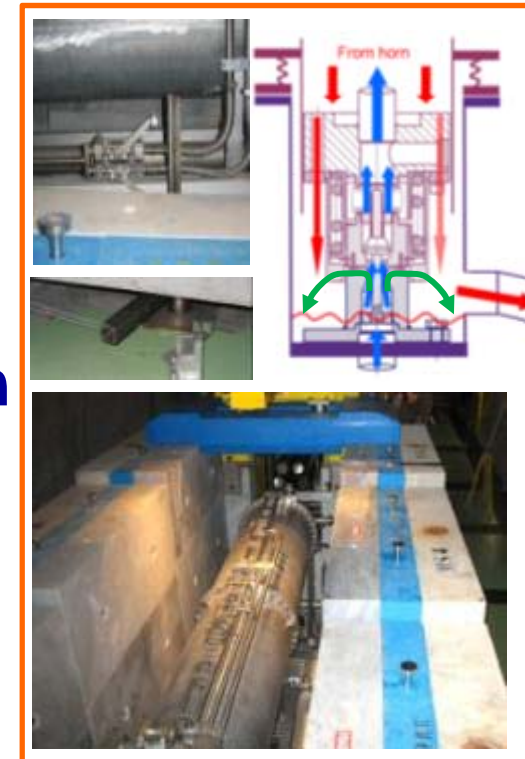

# CNGS Horn Operation I



- **07/'06 – 09/'06: commissioning + first run**
- **10/'06: Reflector water leak (4E5) (refill rate & sump level)**
  - Beam stopped early, investigation, 1 water outlet broken
  - New design, replace all outlets & inlets on horn & reflector
  - Link new alarm to refill rate
- **08/'07 (before beam start): Broken stripline cable discovered**
  - Preventively, install reinforcement for 2008 run (service gallery!)
- **10/'07: Electronics of cavern ventilation fail**
  - Beam stopped early, major works 2007-2008
  - Install new stripline plates for horn & reflector
- **06/'08: Beam start (we keep our fingers crossed)**





# CNGS Horn Operation II



## Water outlets and inlets

- **Old design (outlets):**
  - In-house, Ti-ceramic, machined, **brazed**
  - Bellows absorbs misalignments
  - Shear stress from brazing (thermal) too high
- **New design (inlets & outlets):**
  - No brazing, soft seal, compression
  - Rigorous testing on spare horn
  - Replace all 10 outlets preventively
  - Replace all inlets preventively (+extras)

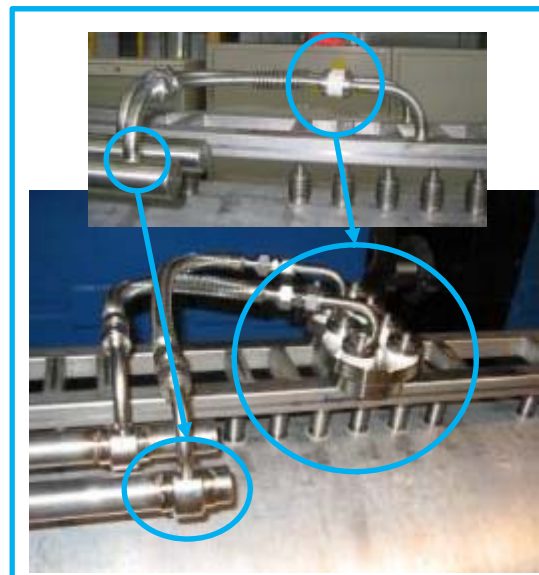
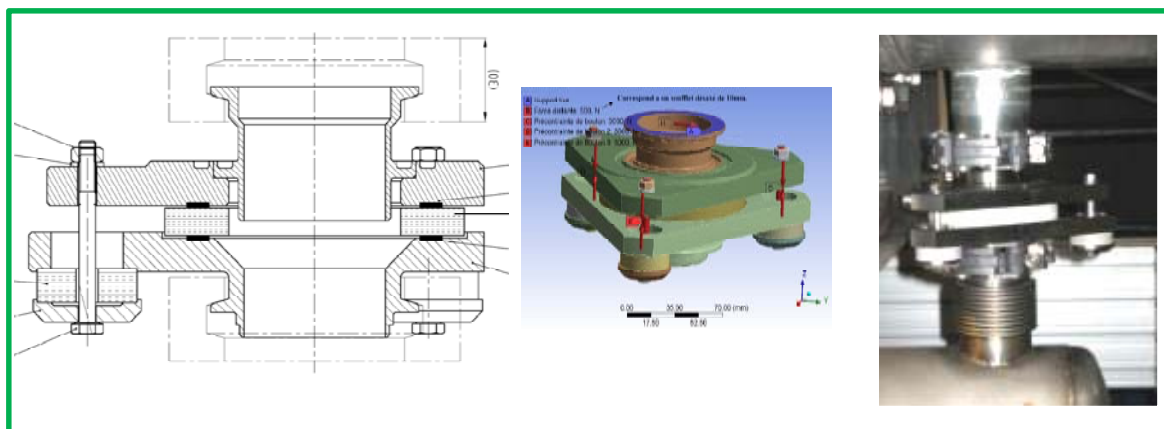

# CNGS Horn Operation III



- **Exchange work**

Water outlets and inlets

- Upstream in Target chamber ( $1\mu\text{Sv/hr}$ )
- Remote horn handling worked very well ( $<50\mu\text{Sv}$ )  
(thanks to procedure, tools, films, photos, training)
- Close collaboration with RP group
- Dose planning, additional shielding, training, tools, camera  
→ Total dose H+R  $\sim 1.6\text{mSv}$

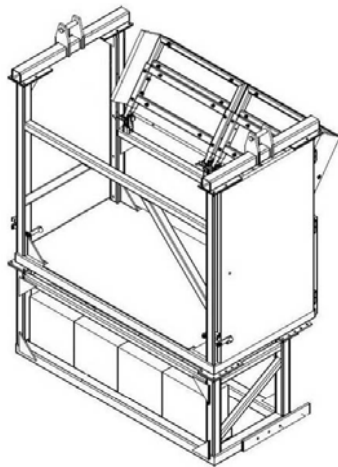



# CNGS Horn Operation IV



Flexible stripline connection to transformer

- **Old design (WANF extrapolation):**
  - Clamped plates, twisted cables, **brazed**
  - Large displacements from magnetic forces between plates (vibration of  $\pm 2\text{mm}$  measured)
  - Fatigue broke weakened reflector cable & strands
- **New design:**
  - No brazing, semi-flexible, fully clamped plates
  - Reliable, calculated, vibrations measured ( $\pm 0.2\text{mm}$ )
  - Replace both horn & reflector striplines (service gallery)

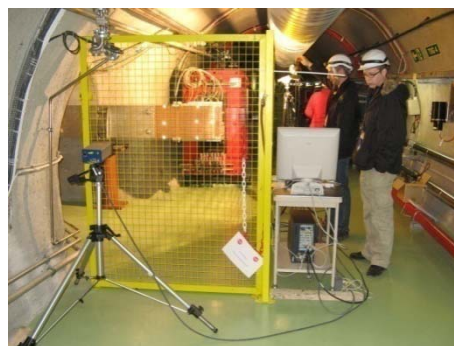
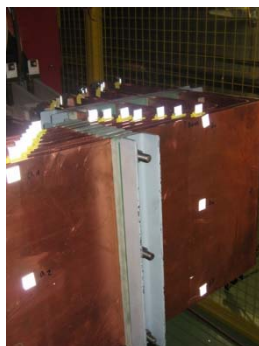
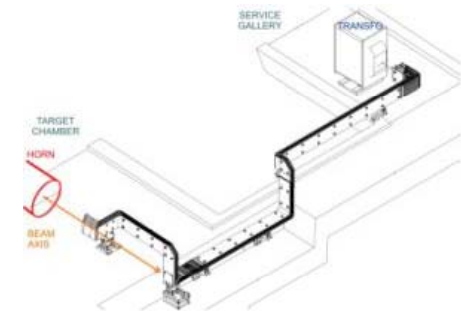

# CNGS Horn Lessons



## Lessons learnt:

(Concentrate on accessory systems)

- Insulation water lines
  - Ceramics OK but delicate → no brazing
- Flexible stripline connection
  - Magnetic forces → large stresses: calculate & measure
  - Beware of “extrapolating existing configurations”
- Radiation (similar to NuMI):
  - Repair is (sometimes) possible but is major operation.
    - Design sturdy & reliable but with “early repair” in mind
    - Eliminate “children’s diseases” by test before beam
      - Investment in tooling, training, procedures, films, photos etc. paid off: Smooth remote exchange
  - Invest in spares

# T2K Future Beam Line & Horns

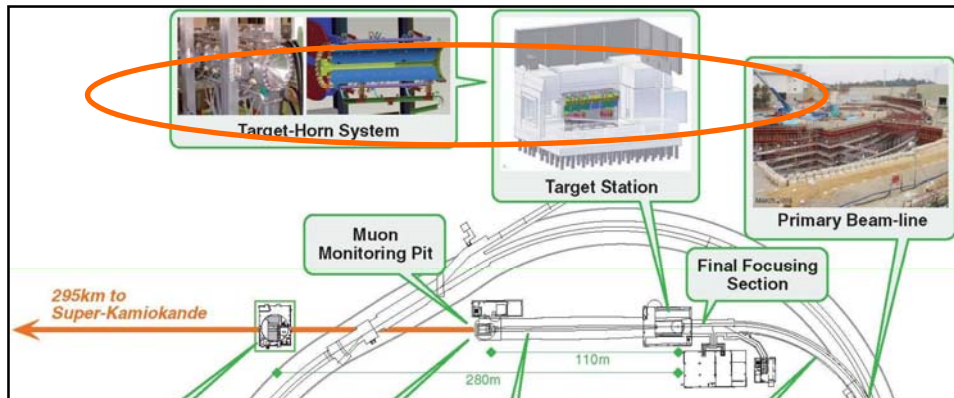

- **320kA, 0.5Hz**
- **50GeV / 3E14 ppp**

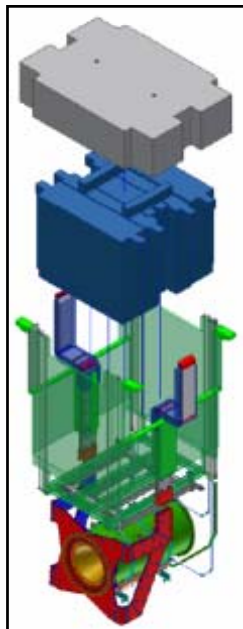

- **Remote connect / disconnect from top (NuMI-inspired)**

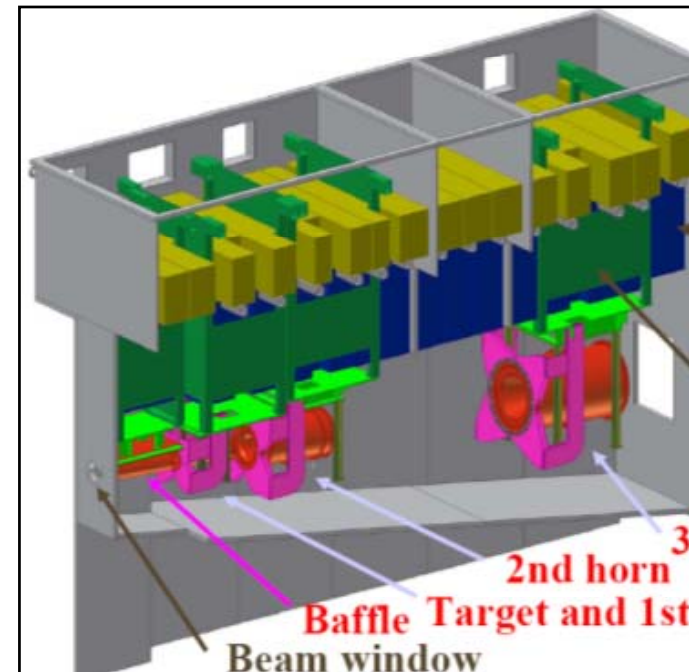



# T2K Horn Features



L. Bartoszek, BartoszekEngineering

- **Cooling, even for support structure**
- **Fully clamped striplines**
- **Water line insulation without brazing**  
(see next slide)
- **Horn 2: Friction Stir Welded inner conductor (fatigue resistance)**

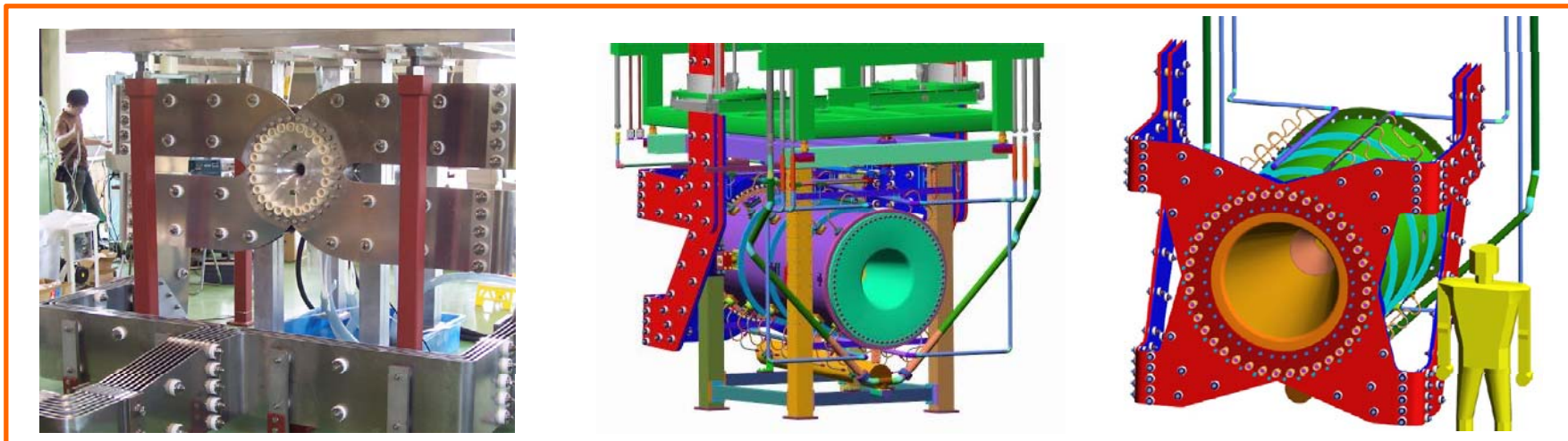

04/07/2008

Ans PARDONS, NuFact2008

27



# T2K Horn Features II



Horn 2 Water lines:  
Pictures from BartozekEngineering

- **From K2K**
  - Semi-rigid supply lines (thermal expansion)
- **From MiniBoone**
  - Auxiliary drains for lower connections
  - Careful choice of seals (galvanic corrosion)
- **From NuMI & CERN**
  - Ceramic is fine, but avoid brazing

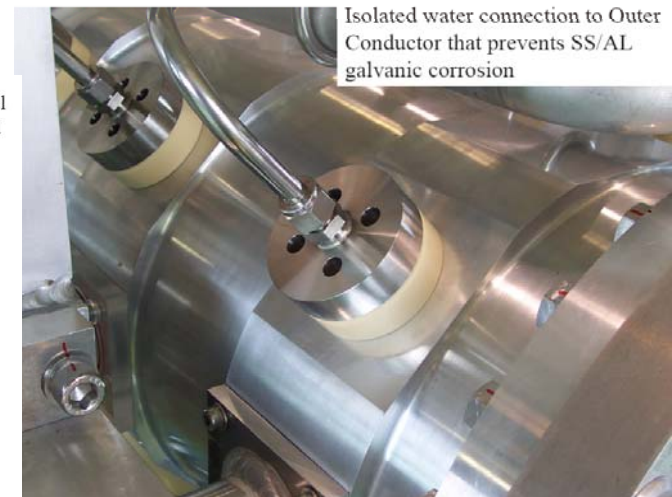
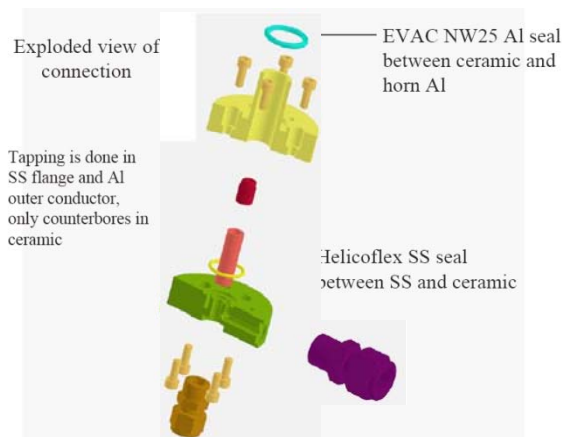
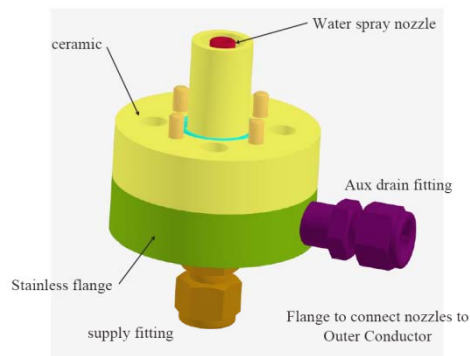
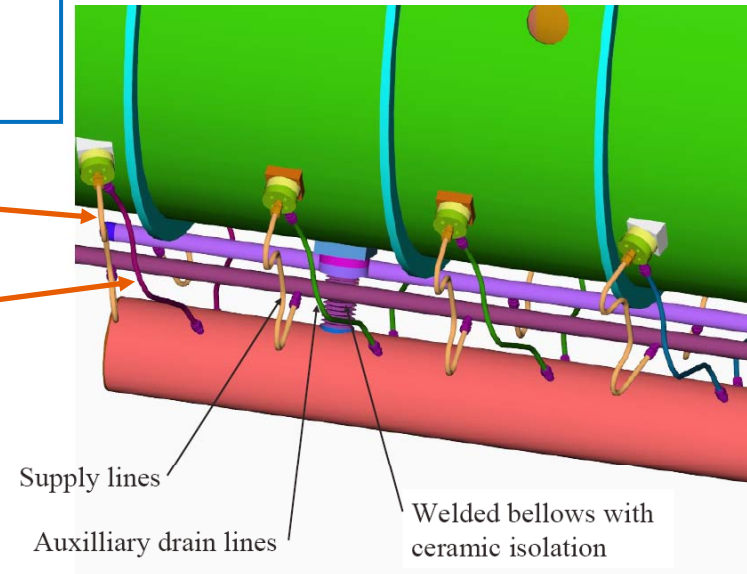

# Summary



- **Fatigue stress in conductors**
  - Still important, but understood & material data available
- **Design accessory systems as sturdy as possible**
  - Careful choice of materials & techniques
  - Redundancy where possible
  - Everything vibrates (& everything sees radiation)
  - Test entire horn system without beam (~5E5 cycles)
- **There will always be bad surprises!**
  - Design for remote repair (for early surprises) and remote exchange (later on)
  - Build spares
- **Learn from others & share your experience!**

**NBI2003**

NBI 2005

PAR

NuFact 06  
August 24-30, 2006

08



29

**Thank you!**

**Questions? Remarks?**

**Many thanks to Larry Bartoszek, Sam Childress,  
Jim Hysten, Atsuko Ichikawa, Stephane Rangod,  
Kazuhiro Tanaka for their valuable input.  
(and for moral support during “our” horn failures)**



---

# Extra slides



# Neutrino horns

## Neutrino Horns 101

Aluminium conductors (anodized or not)

Thin, welded, suspended inner conductor

Water cooled inner and outer conductor

Electrically insulated stainless steel cooling circuit

Electrically insulating ring between 'in' and 'out'

Aluminium (Copper) bus bars or striplines

Transformers to convert low Amp (high V) to high Amp (low V)

Only radiation hard materials: metals, glass, ceramic, graphite

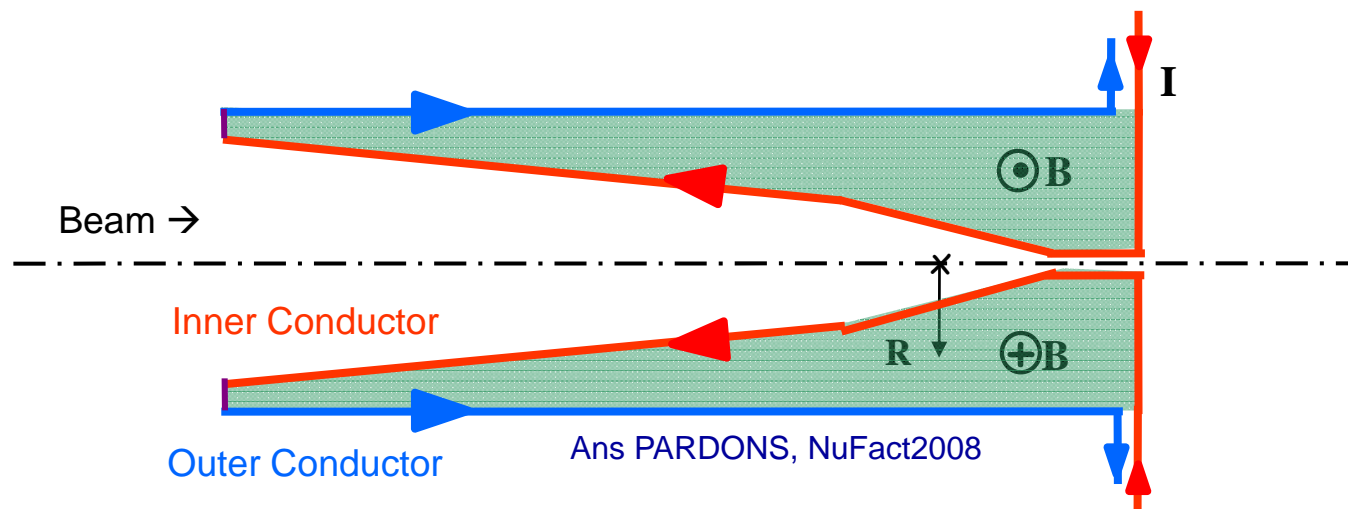

# Overview horns



|   | K2K<br>(‘99-’04) | M-Boone<br>(2002-...) | NuMI<br>(2004-...) | CNGS<br>(2006-...) | T2K<br>(2009) |
|---|------------------|-----------------------|--------------------|--------------------|---------------|
| Number of horns                             | 2                | 1                     | 2                  | 2                  | 3             |
| Current (kA)                                | 250              | 170                   | 200                | 150 / 180          | 320           |
| Nr pulses/beam cycle                        | 1                | 1                     | 1                  | 2                  | 1             |
| Pulse width (ms)                            | 2.5              | 0.15                  | 2.3                | 6 / 10             | 0.7 / 2 / 2   |
| Avg. freq. (Hz)                             | 0.5              | 5                     | 0.5                | 0.3                | 0.5           |
| Target included?                            | Yes              | Yes                   | Yes                | No                 | Yes           |
| Design life-time (1E6 pulses or eqv. years) | 10 ~1 yr         | 100 ~1yr              | 10 ~1yr            | 40~4yr             | ?             |

# K2K Target



- **07/'99 H1: 20mm diam. Al Target rod breaks from fatigue stress (2E6)  
→ install new H1 with 30mm target (lasted 11E6 > 7E6)**

The reason of unexpected failure was the absence of reliable fatigue strength data for Aluminium.

In our calculations, the results are:

20 mm diameter “may be safe” for a million pulses.

25 mm diameter → several million pulses.

30 mm diameter → more than ten million pulses.



Physicists requested a 20 mm diameter Al rod as a target (and a part of vibrating inner conductor) because they thought the high magnetic field at the surface of the target would increase the pion intensity with 100% (in reality it was 10%) At that time we could not find enough reason to refuse 20 mm target. We recommended to use 25-30mm diameter target for safety, but the neutrino physicists rejected our opinion.

After the first run of K2K, the 20 mm diameter target failed (after 2 million pulses). We then decided to impose our opinion and use a 30 mm diameter target.

The first 30 mm target survived 11 million pulses and was broken accidentally due to a wrong operation.

The second 30 mm target lasted 7 million pulses, when the inner conductor broke as "designed".

Lesson: 😊

“Never compromise with physicists”

# Aluminium fatigue strength



Fatigue strength (f.s.) is reduced by:

- Imperfections
  - IC rather smooth, OT low stress anyway
- Heat treatments: welding
  - Fatigue strength reduction of 50%
  - Friction stir welding looks good!
- Stress ration ( $R=S_{min}/S_{max}$ )
- Moisture, corrosion

12-27. Alloys 3003-O, 5154-H34 and 6061-T6: Effect of Alloy on Fatigue Characteristics of Weldments

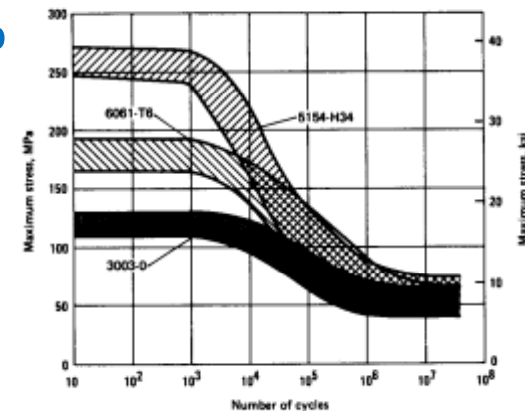

The fatigue life of welded joints at high loads varies with the alloy. As the load is decreased, differences disappear until, at about one to ten million cycles of axial loading ( $R = 0$ ), the fatigue strength of an arc-welded joint is approximately the same regardless of alloy and is 50 to 70% that of the unwelded alloy. Typical data are given in the above graph for three aluminum alloys. Specimens were from 9.5-mm ( $\frac{3}{8}$ -in.) plate; weld reinforcement removed; axial loading;  $R = 0$ .

L. Bartoszek, NBI 2000

Ans PARDONS, NuFε



# Mechanism and Merit of FSW (Friction Stir Welding)

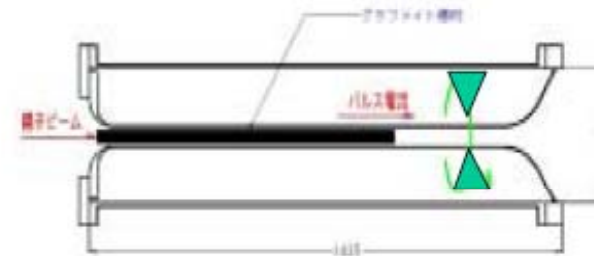
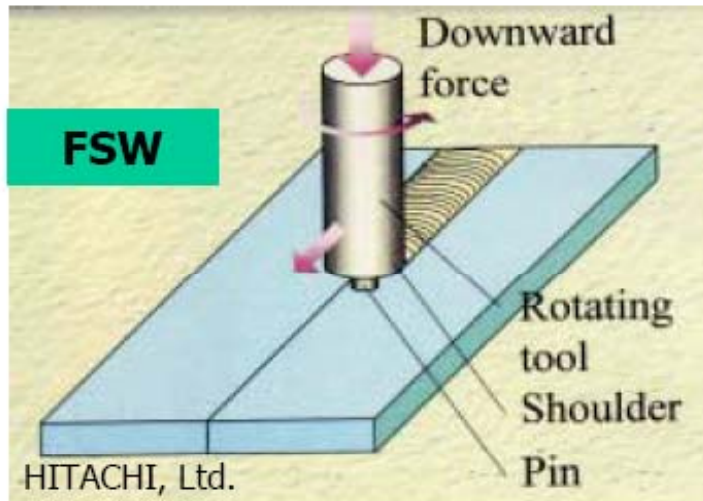

- Invented at TWI(1991)
- Applied to space rocket, train body
- Very low distortion
  - Good dimensional stability and repeatability
- Fully mechanical process
  - No fume, porosity or spatter
- Excellent mechanical/metallurgical properties
- Very cost effective

