

Optical Diagnostic Results of MERIT (Mercury Intense Target) Experiment at CERN

H. Park , H. Kirk, T.Tsang, K. McDonald, F. Ladeinde

**NFMCC Meeting
Fermilab, Batavia, IL**

March 18, 2008

Acknowledgments: DOE/BNL

Talk Outline

- Optical Diagnostics Setup
 - Optics configuration with respect to beam, magnet, and Hg jet
 - Schematics of optical diagnostic setup
- Observation of Hg Jet Interacting with Proton Beam
 - B field effects to Hg jet break up and vertical splash velocity
- Image Processing For Analysis
- MHD Results
 - Hg jet size, Hg jet surface fluctuation, and longitudinal Hg jet velocity
- Beam Integrated MHD Results
 - Beam intensity threshold and intensity scan
- Conclusions

Optics Configuration with respect to Beam, Magnet, and Hg Jet

Total 360 of beam shots performed.

Images for 227 beam shots collected.

MERIT beam shot summary website,

http://www.hep.princeton.edu/~mcdonald/mumu/target/hkirk/MERIT_Beam_Program_110607.pdf

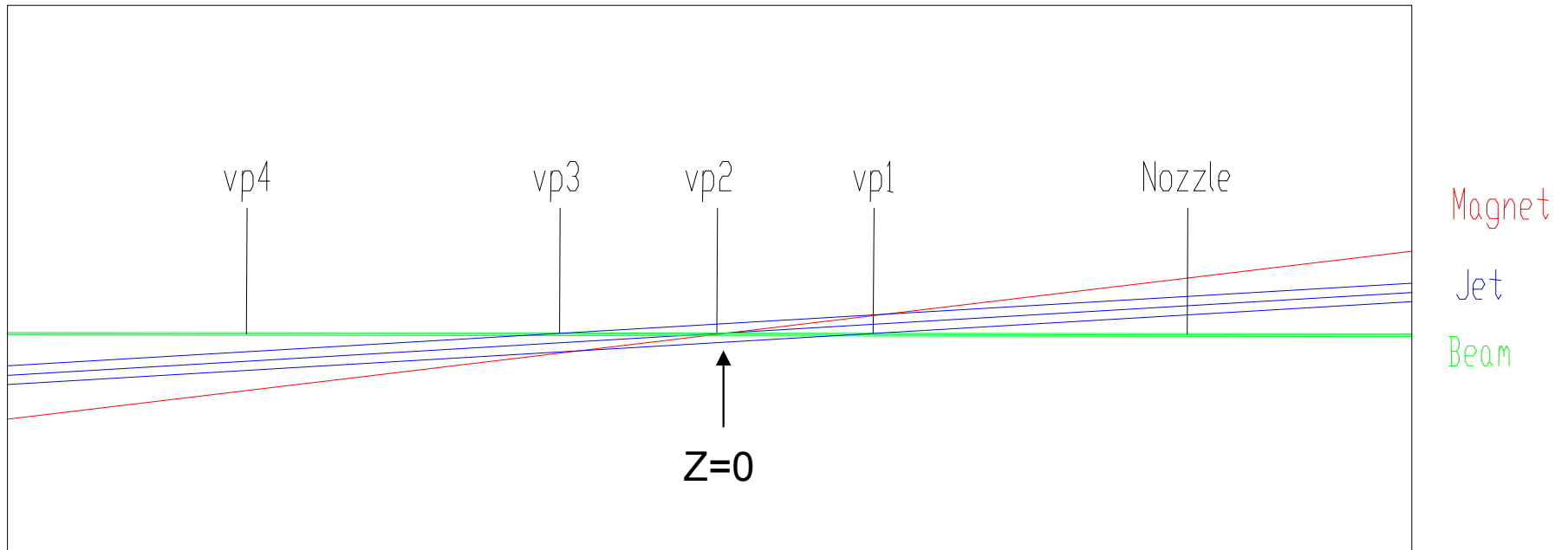
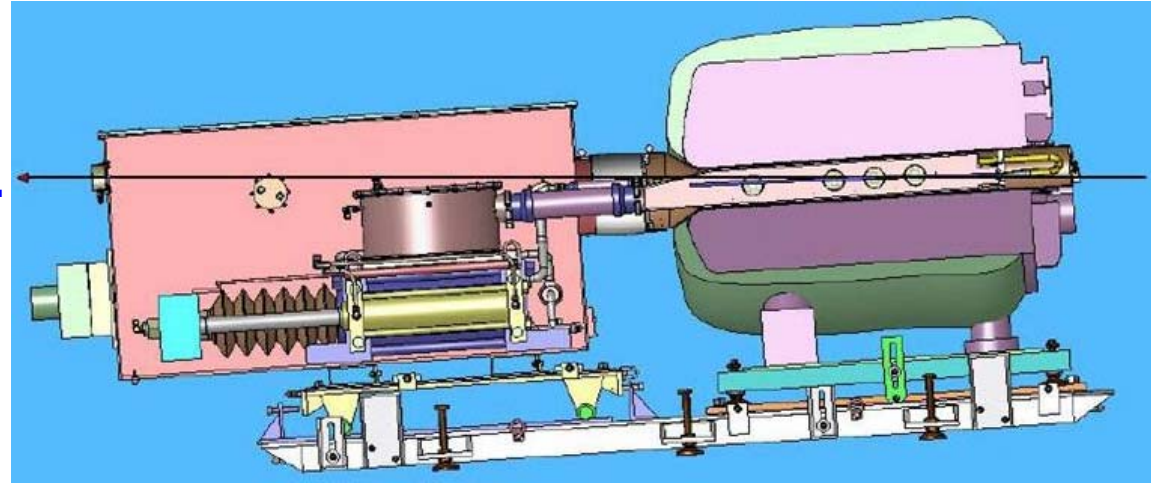

Optical Diagnostics Setup : Laser Pulse Structure, Schematic Diagram

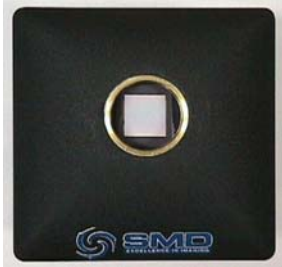
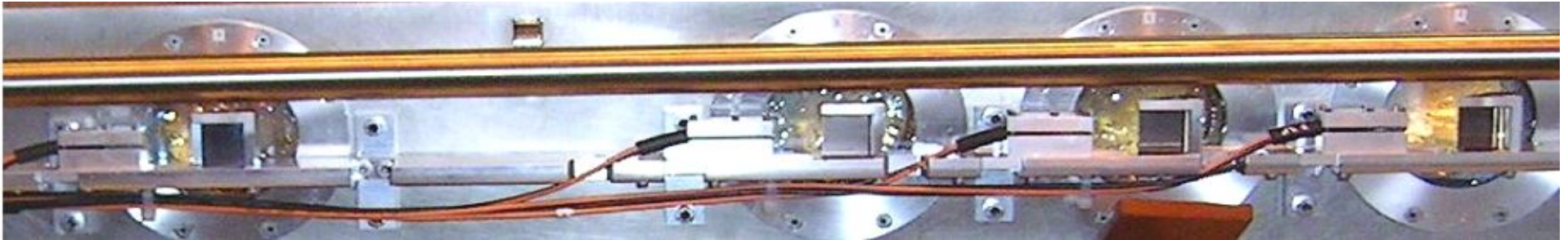

Viewport 4
Olympus Encore Camera
0.25 ~ 2 ms frame rate
60 ~ 100 μ s exposure

Viewport 2
SMD Camera
0.025 ~ 0.25 ms frame rate
0.15 μ s exposure

Viewport 1, 3
FV Camera
0.25 ~ 2 ms frame rate
10~15 μ s exposure

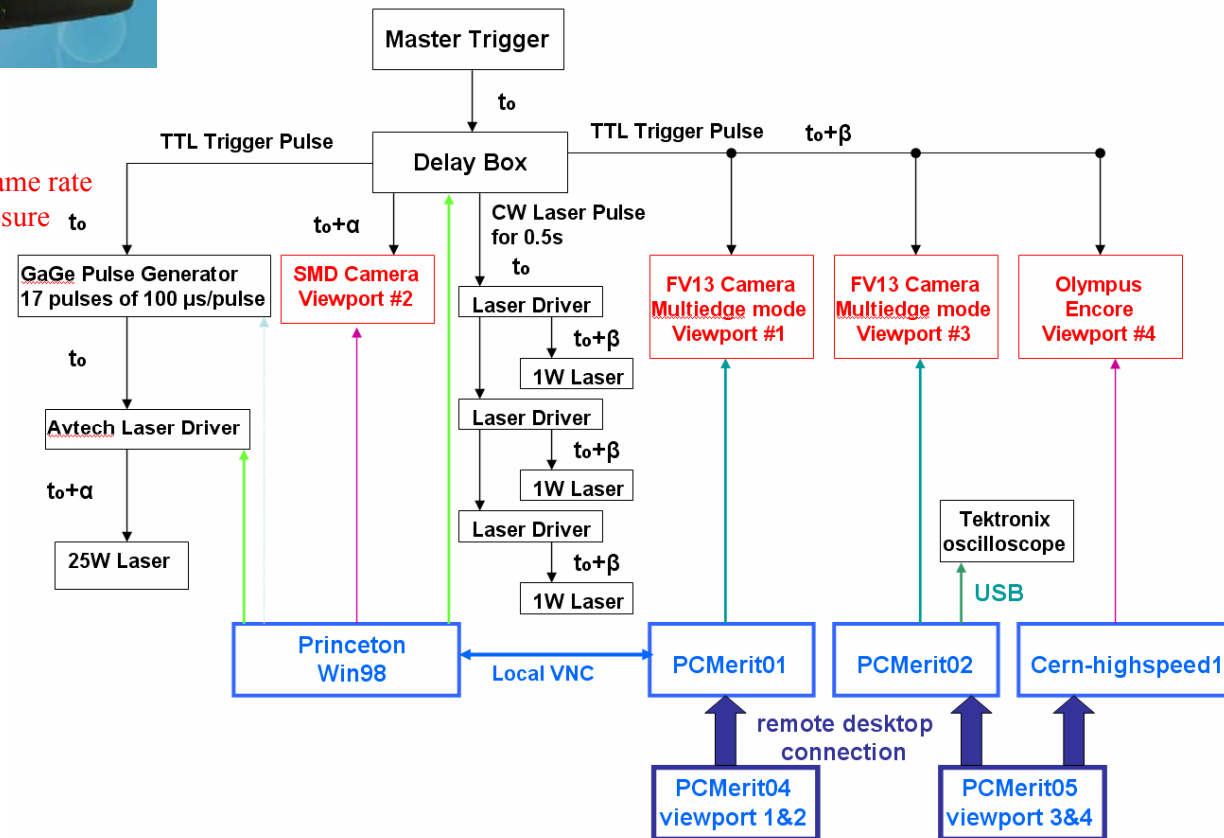
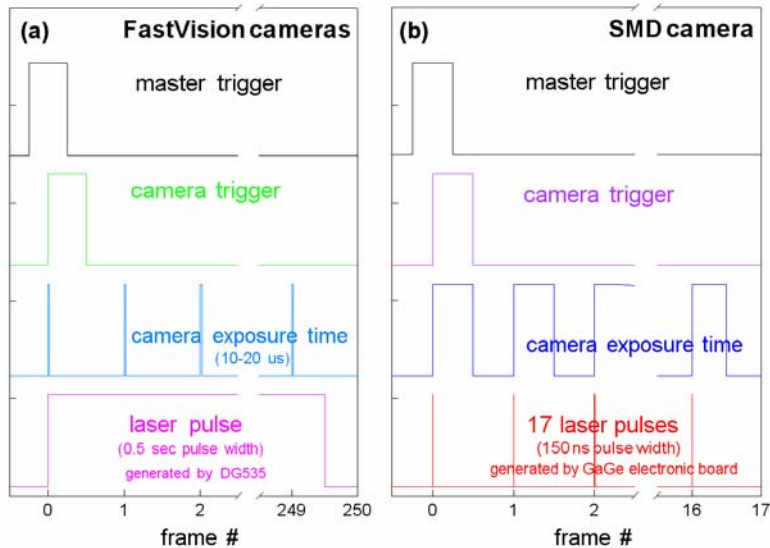

Observation Results : Interaction of Hg Jet with 14 GeV Beam, **Movie**

0T, 8TP

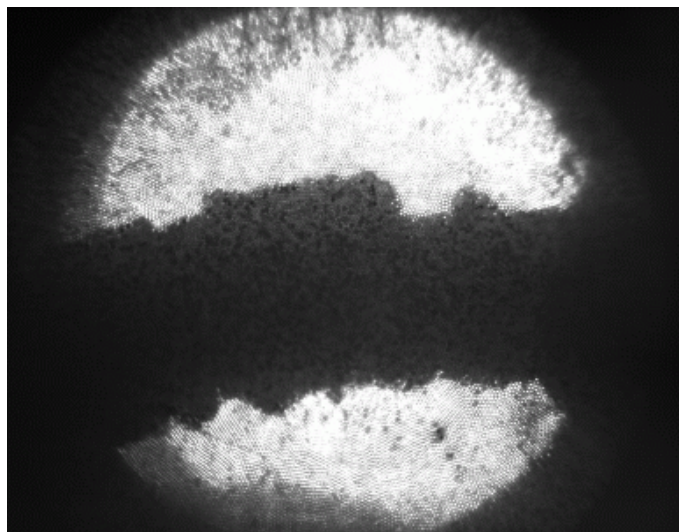

5T, 16TP

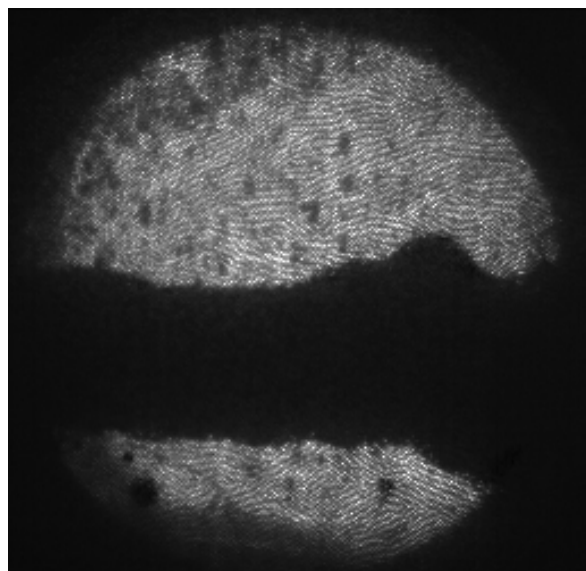

10T, 12TP

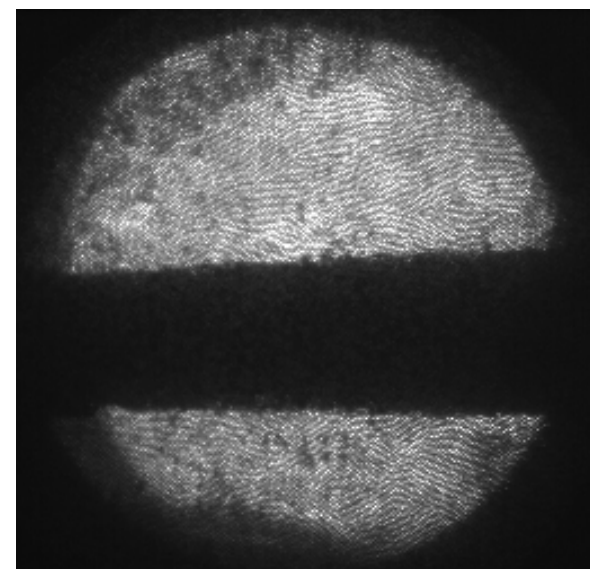

0T, 4TP

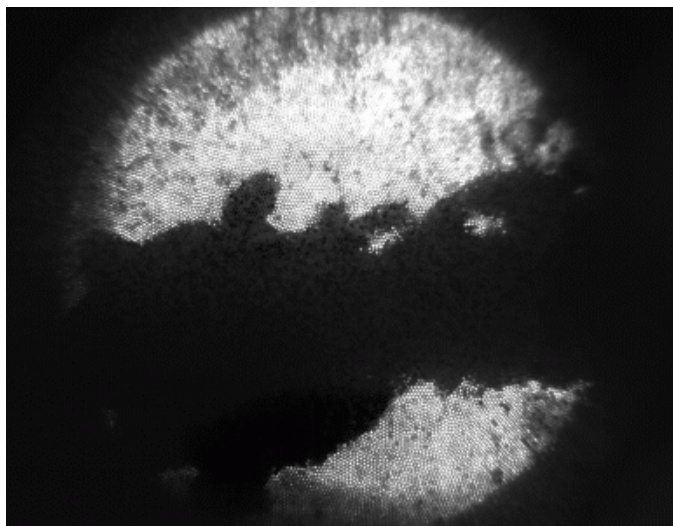

5T, 16TP

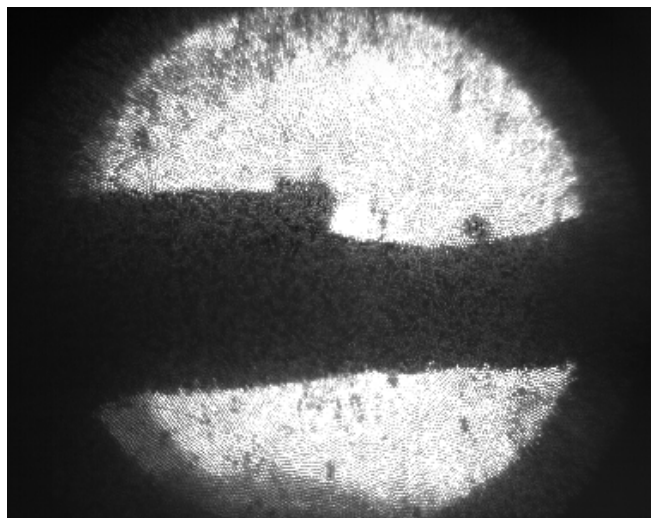

10T, 20TP

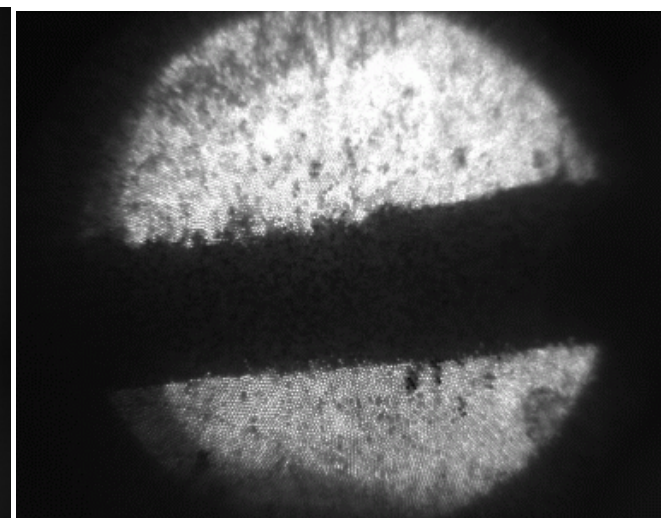

Observation Results: Beam/Hg Jet Interaction

B=5T,P=16TP,E=14GeV, L=28cm

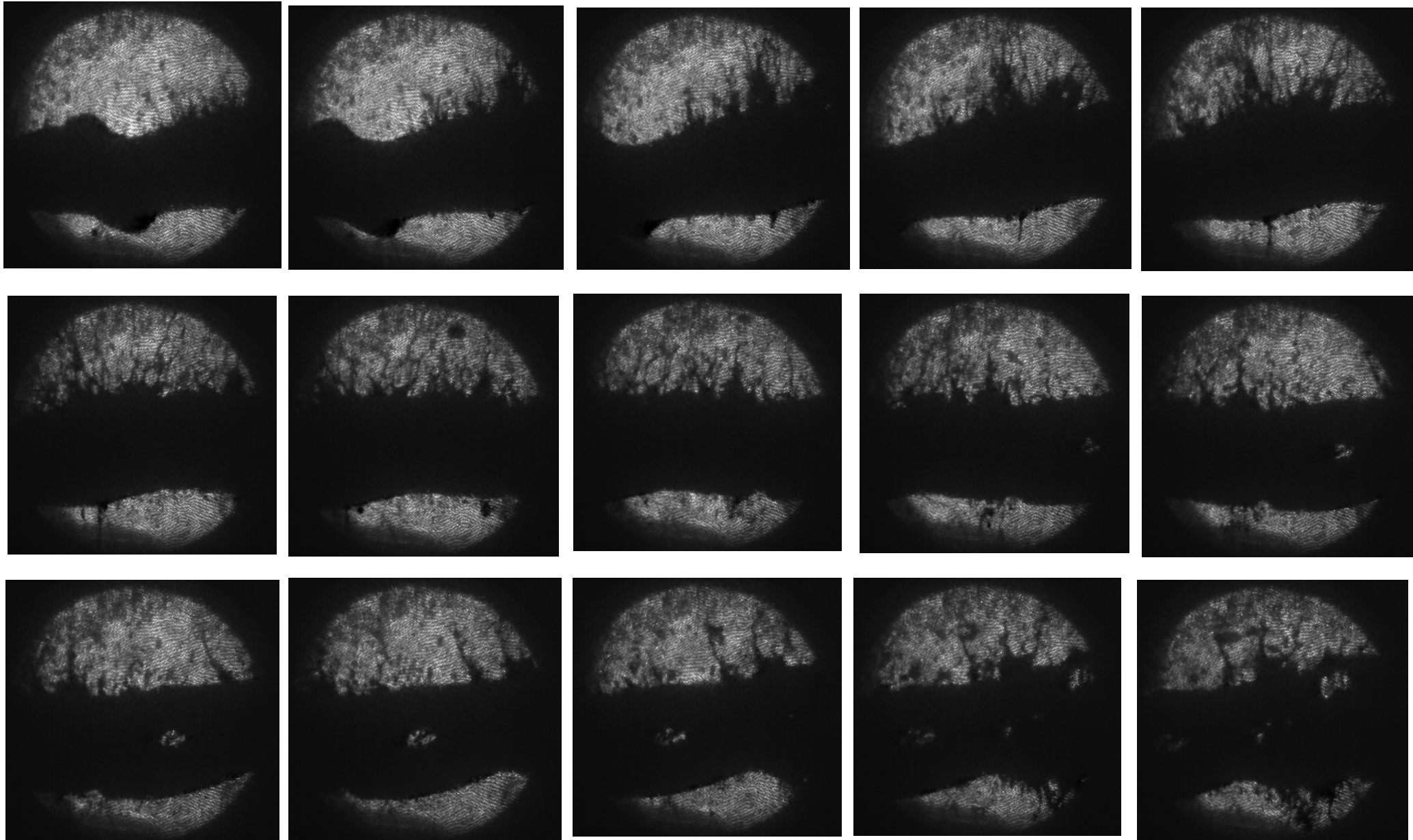

Obsevation Results: Beam/Hg Jet Interaction

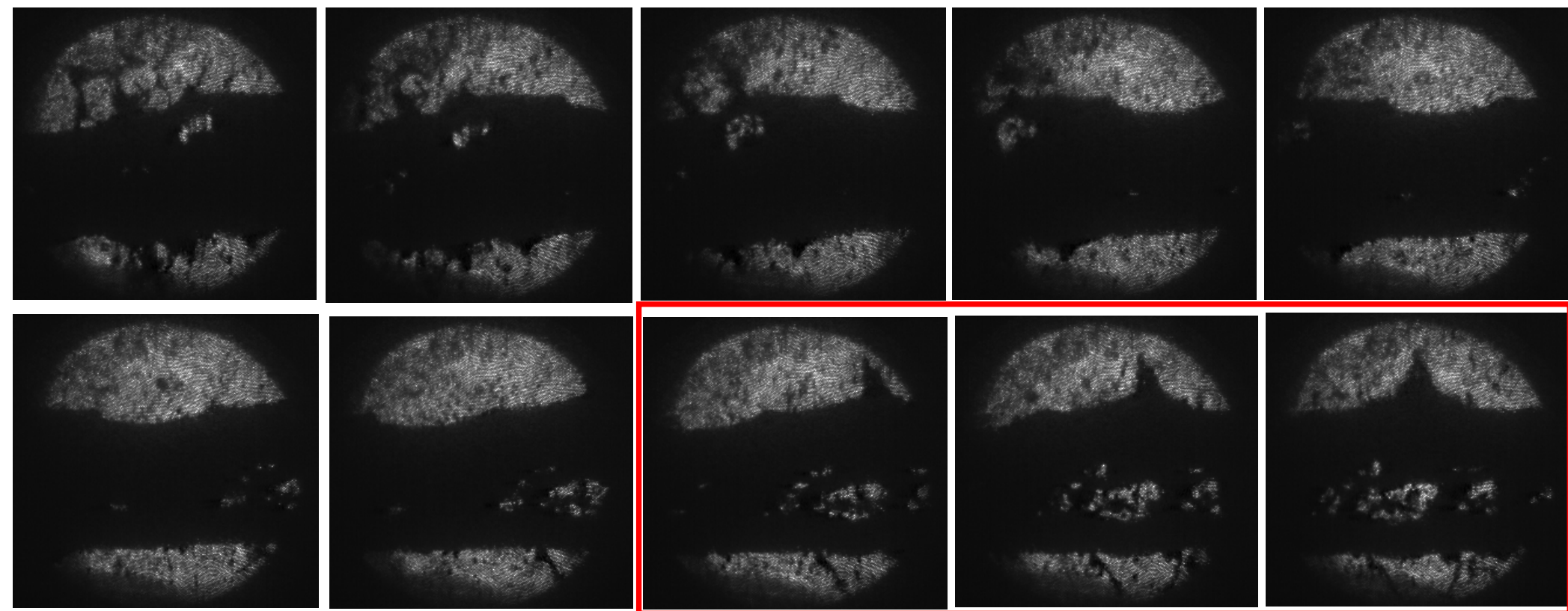

Hg Jet Break Up Center

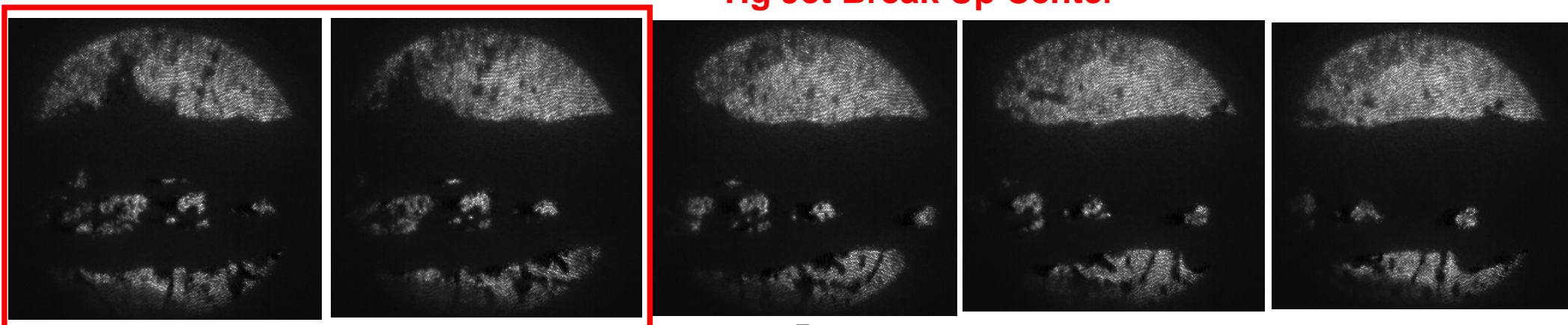

Observation Result: Beam/Jet Interaction

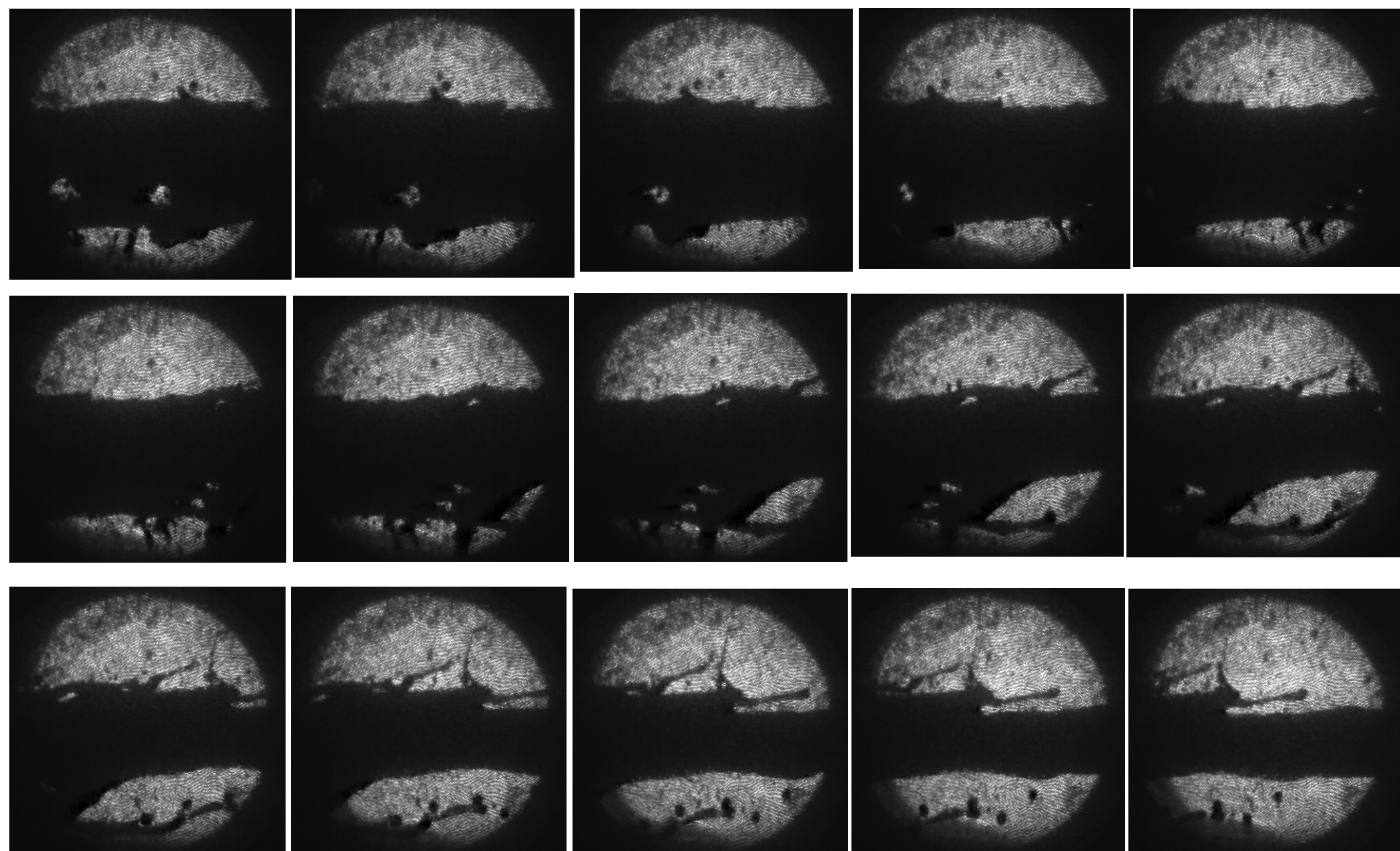

Observation Results: Velocity of Splash with Interaction of 24GeV Beam

3.8TP, 10T

$V = 24$ m/s

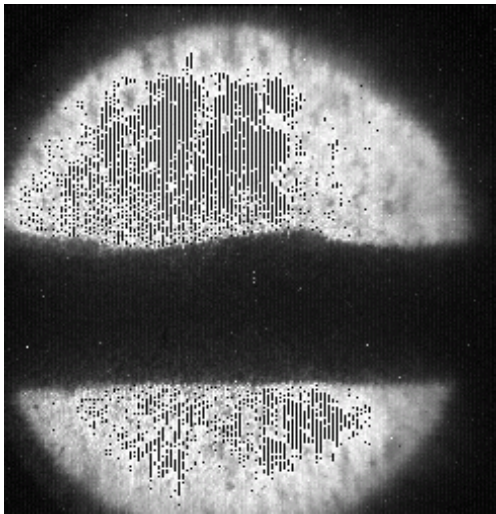

$t=0$

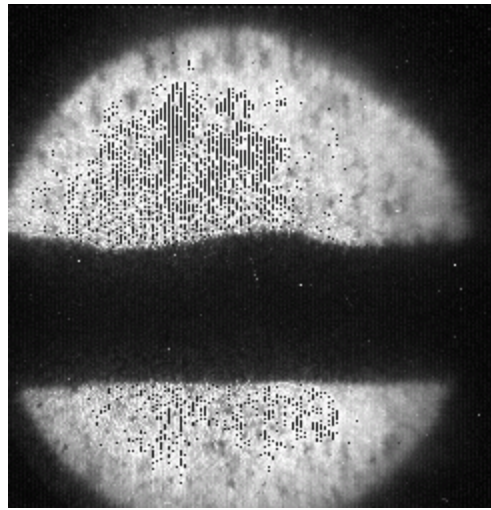

$t=0.150$ ms

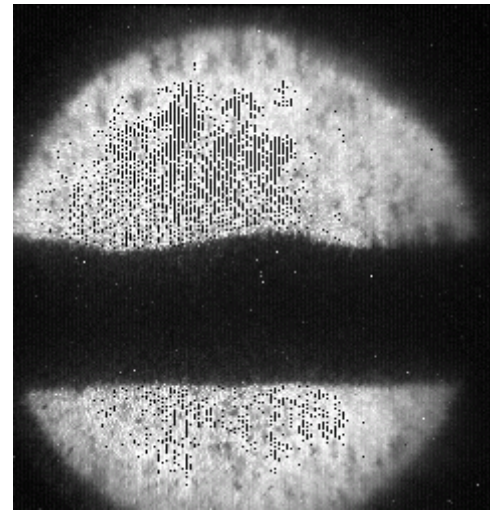

$t=0.175$ ms

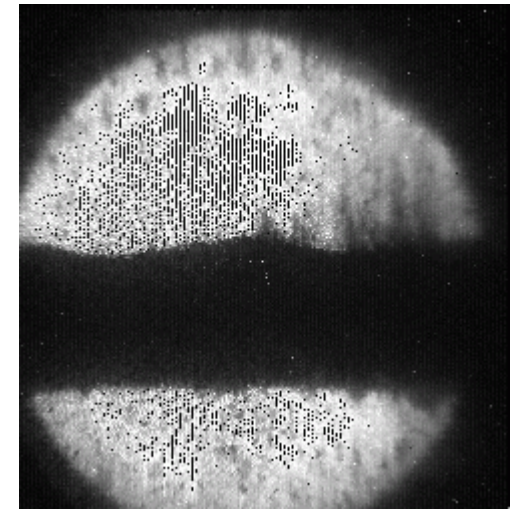

$t=0.375$ ms

6TP, 5T

$V = 47$ m/s

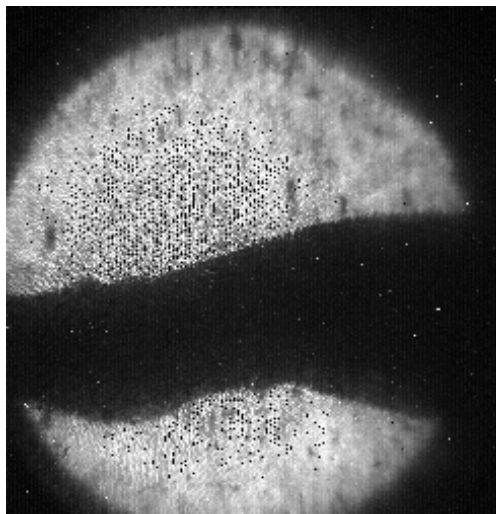

$t=0$

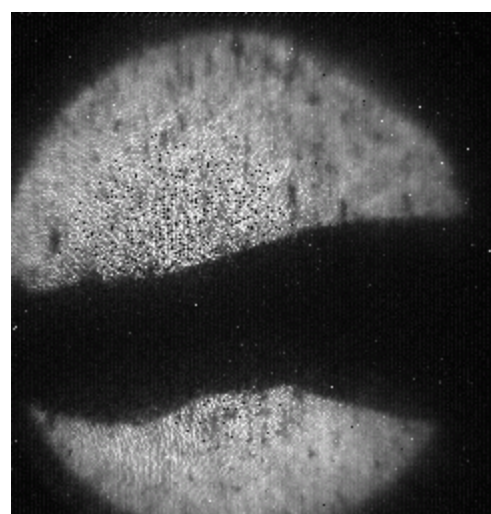

$t=0.050$ ms

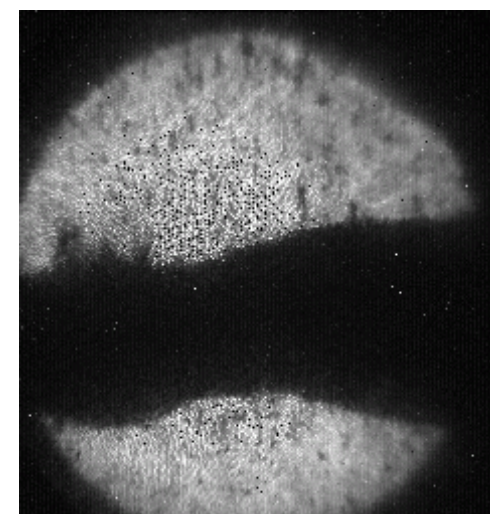

$t=0.175$ ms

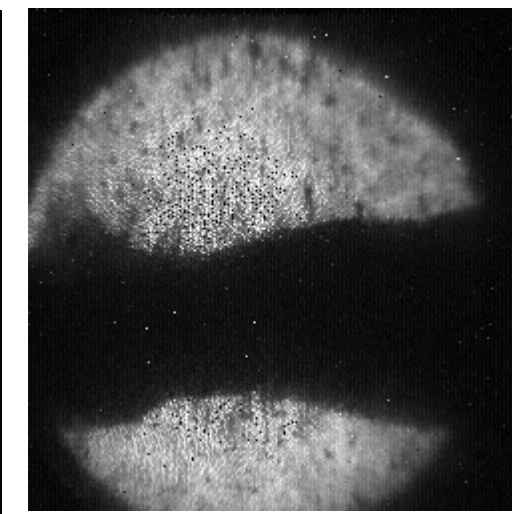

$t=0.375$ ms

Observation Results: Velocity of Splash with Interaction of 24GeV Beam

10TP, 10T

V = 54 m/s

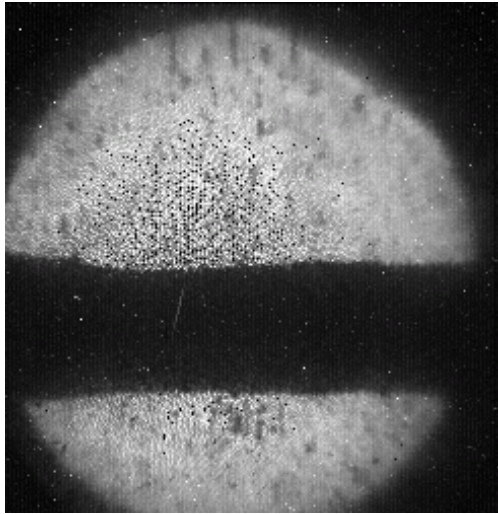

t=0

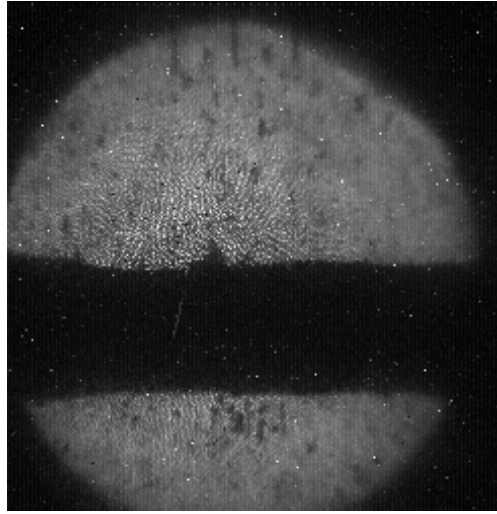

t=0.075 ms

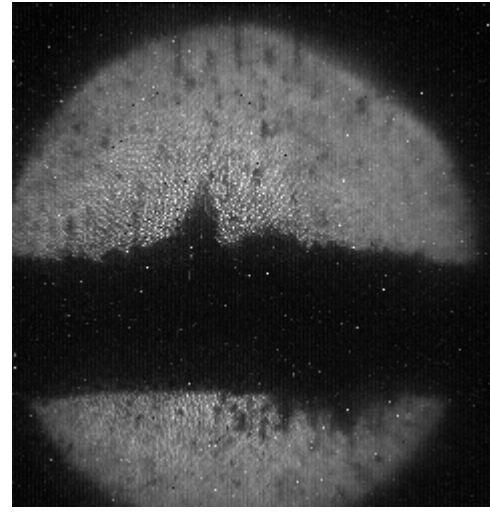

t=0.175 ms

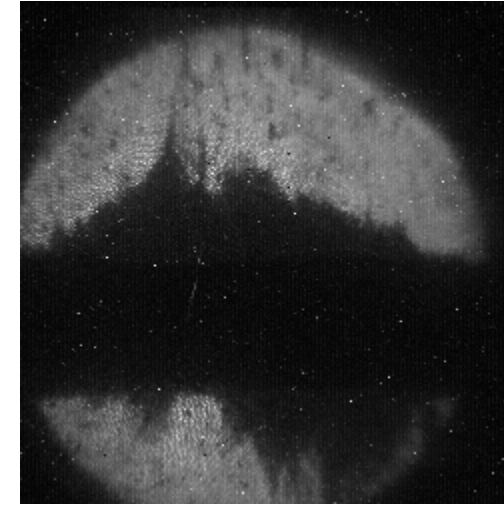

t=0.375 ms

20TP, 10T

V = 65 m/s

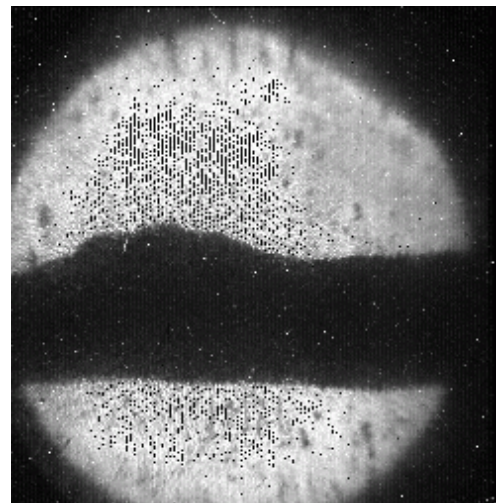

t=0



t=0.050 ms



t=0.175 ms

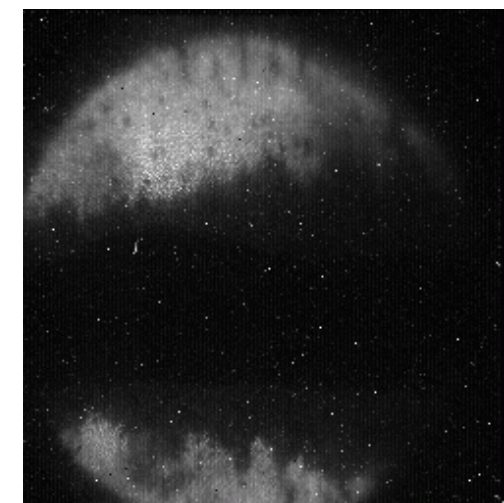

t=0.375 ms

MHD Results: Hg Jet In Magnetic Field, $V=15\text{m/s}$

0.4T

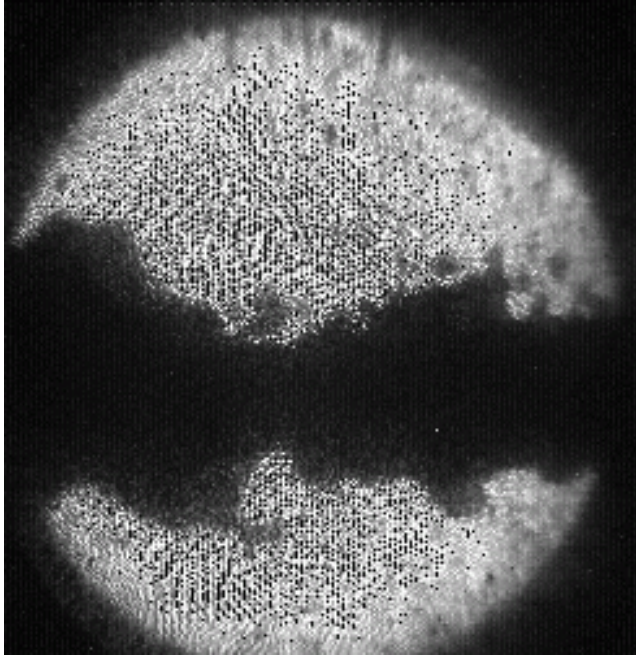

5T

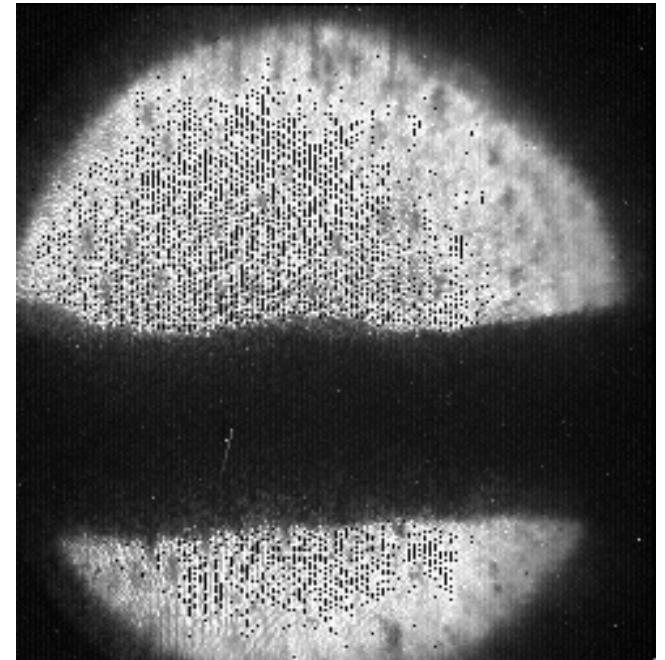

10T

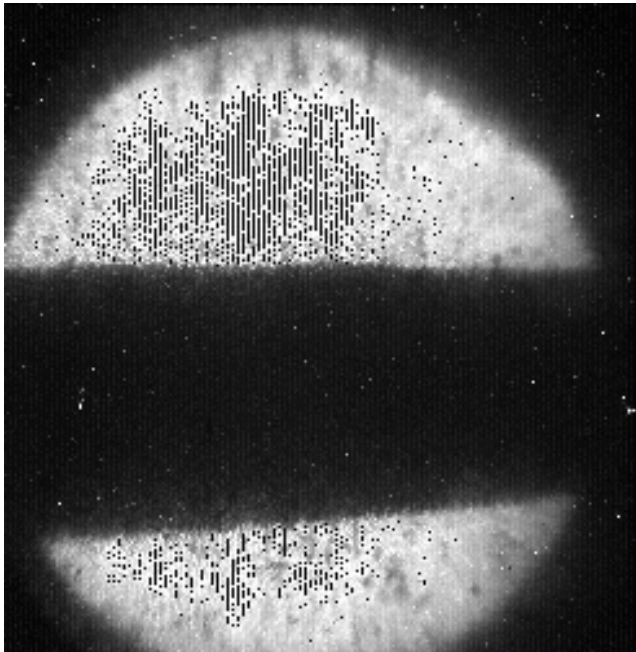

15T

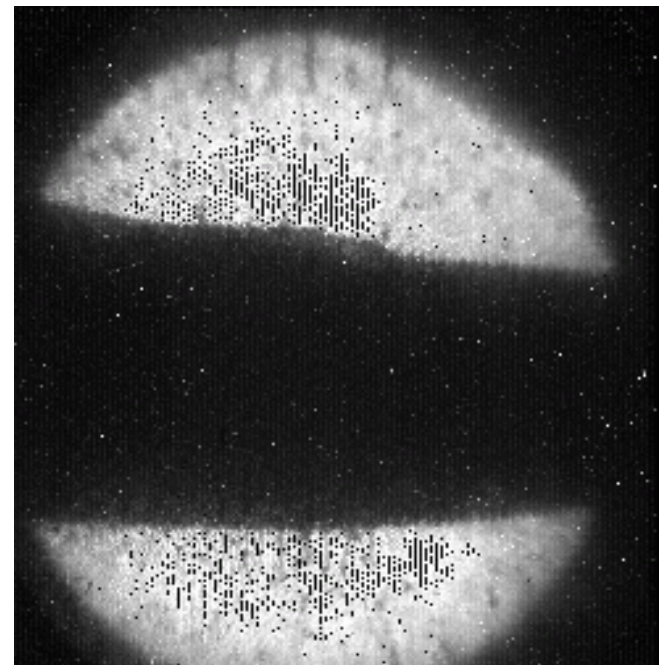

TIF Image Processing Method For Analysis

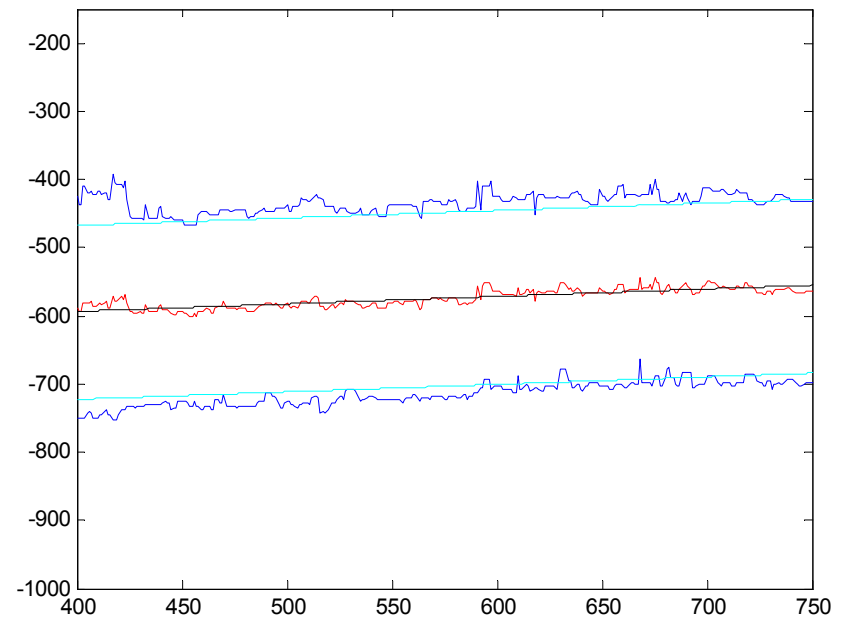
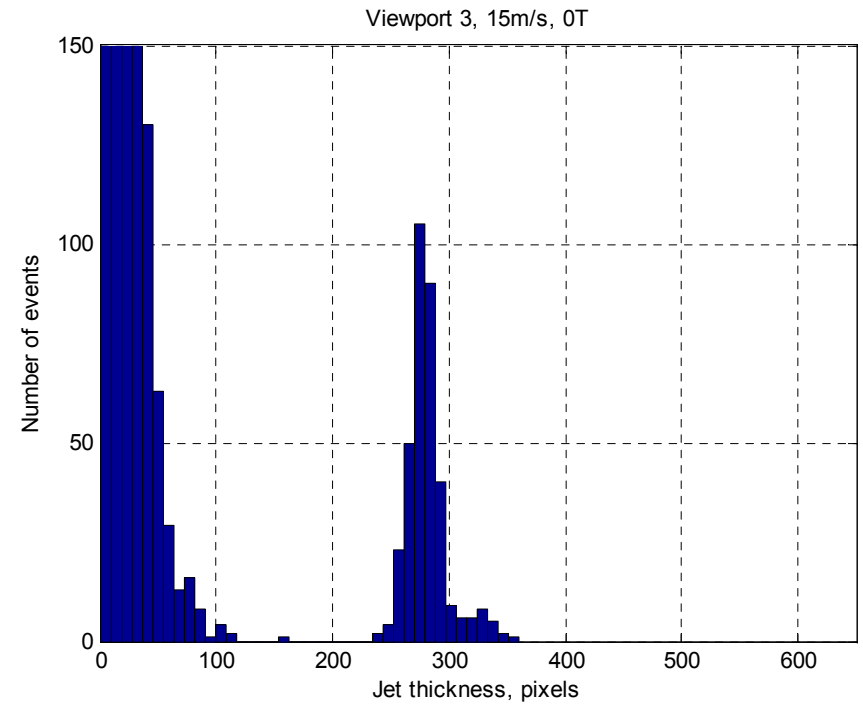
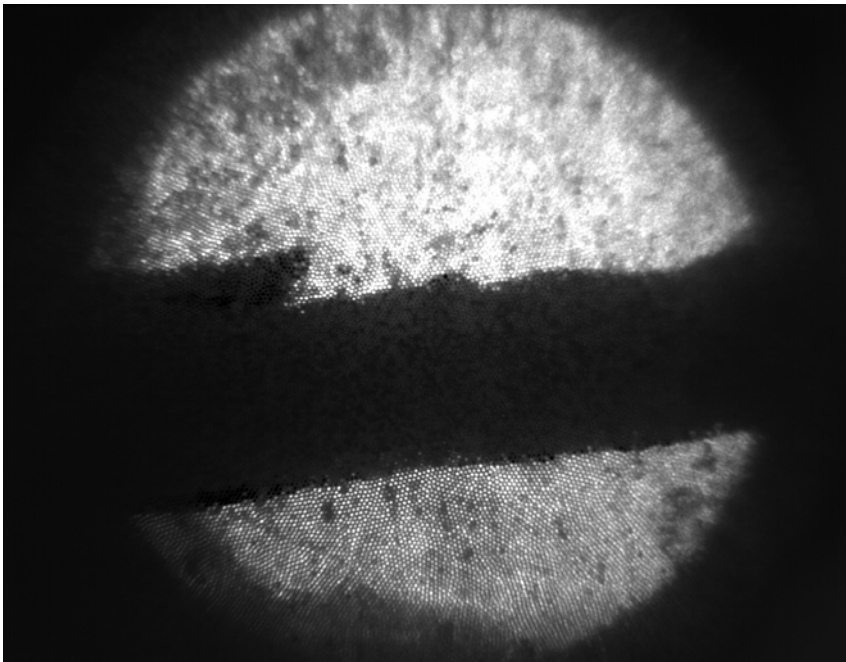
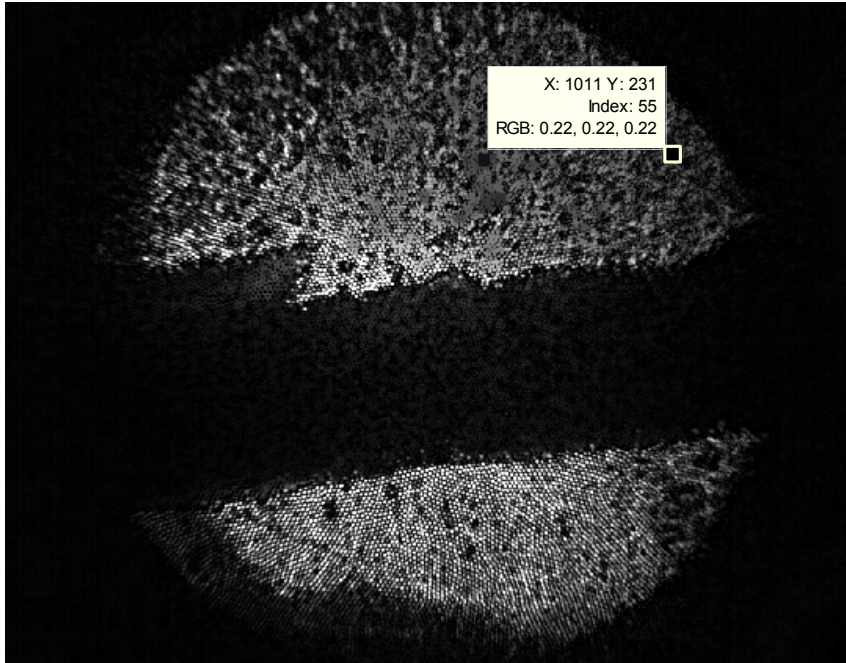

Results: Hg Jet Width Along The Magnet Axis, $V=15\text{m/s}$

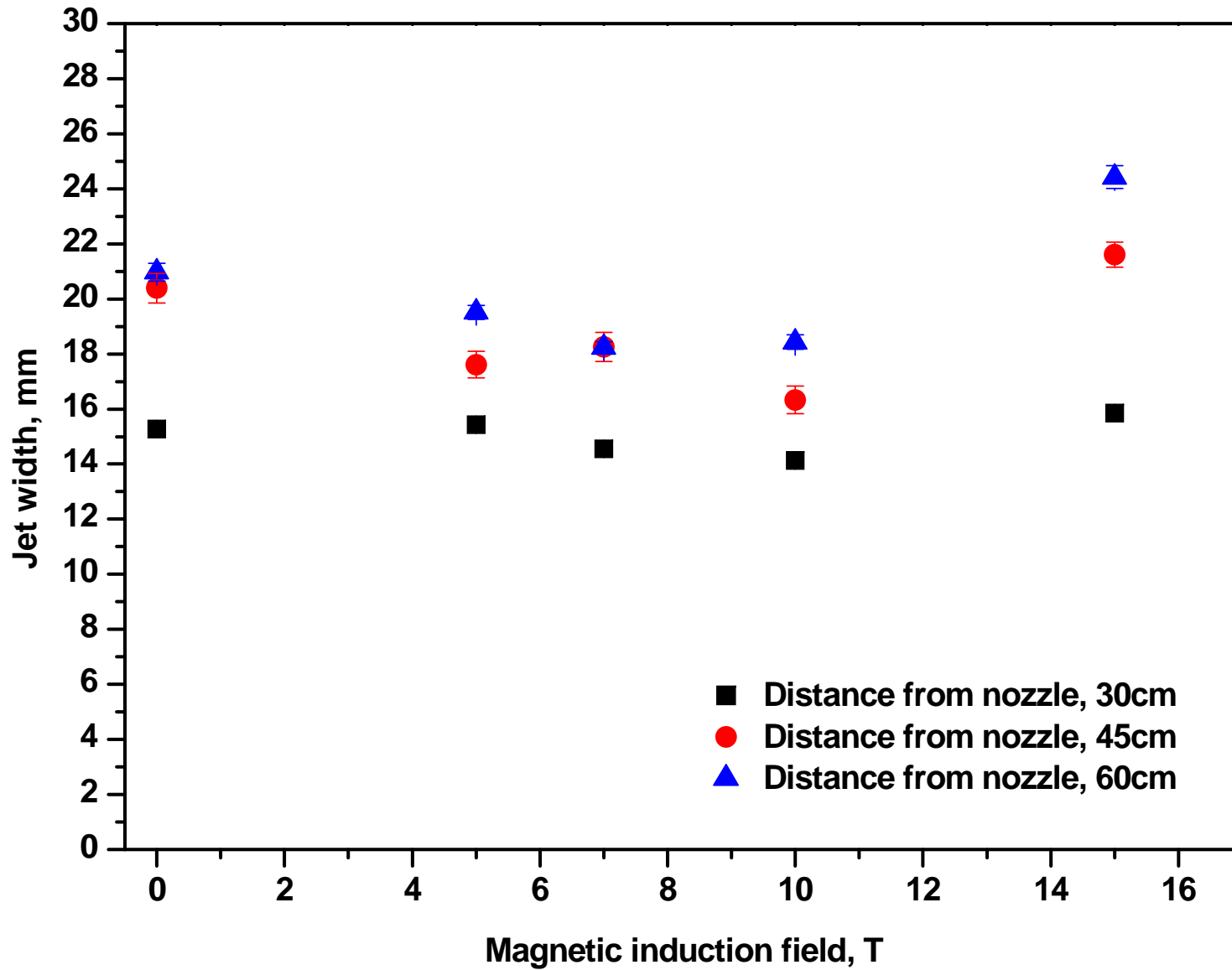

Results: Distortion Ratio Along The Magnet Axis, $V=15\text{m/s}$

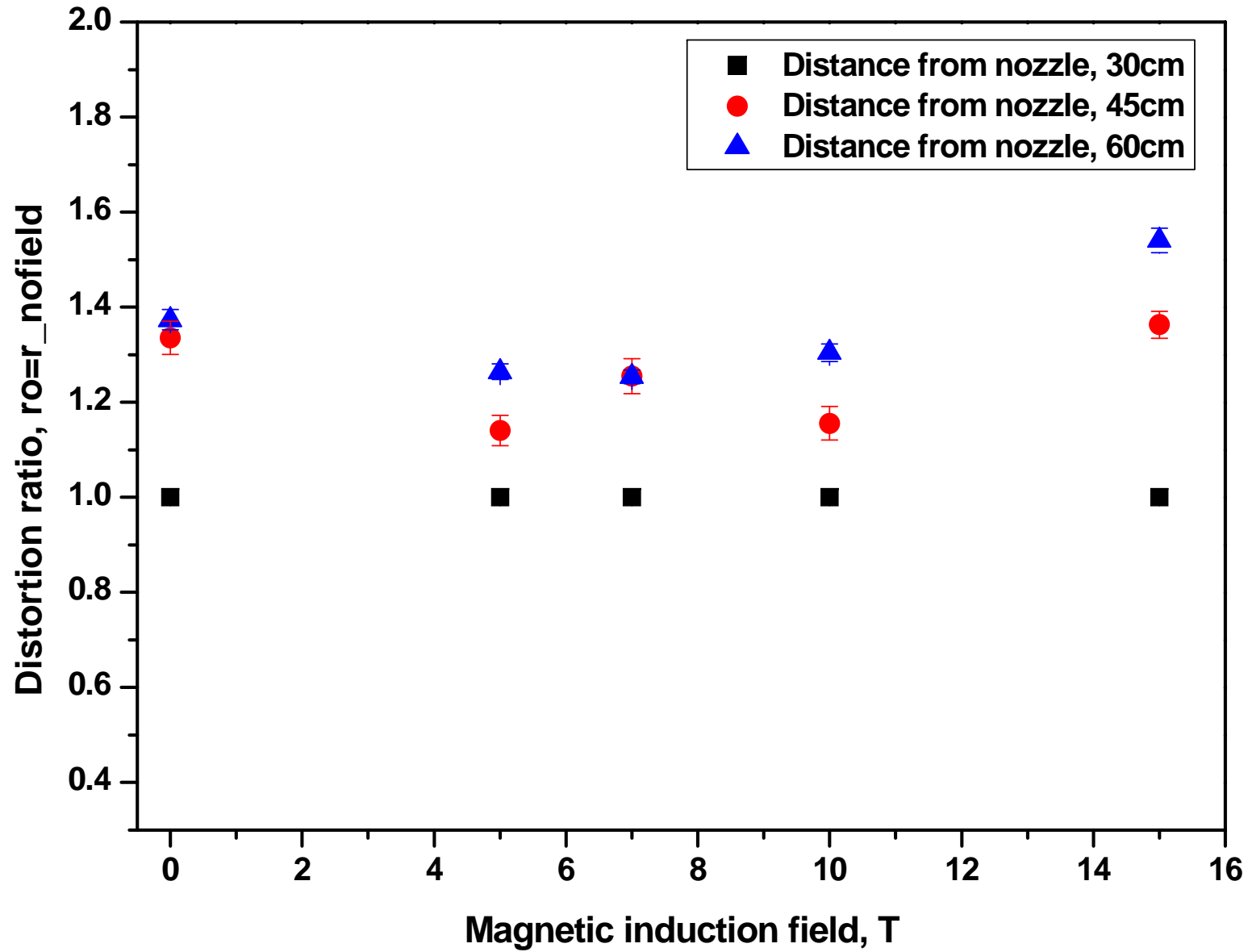

Results: Hg Jet Surface Fluctuations, $V=15\text{m/s}$

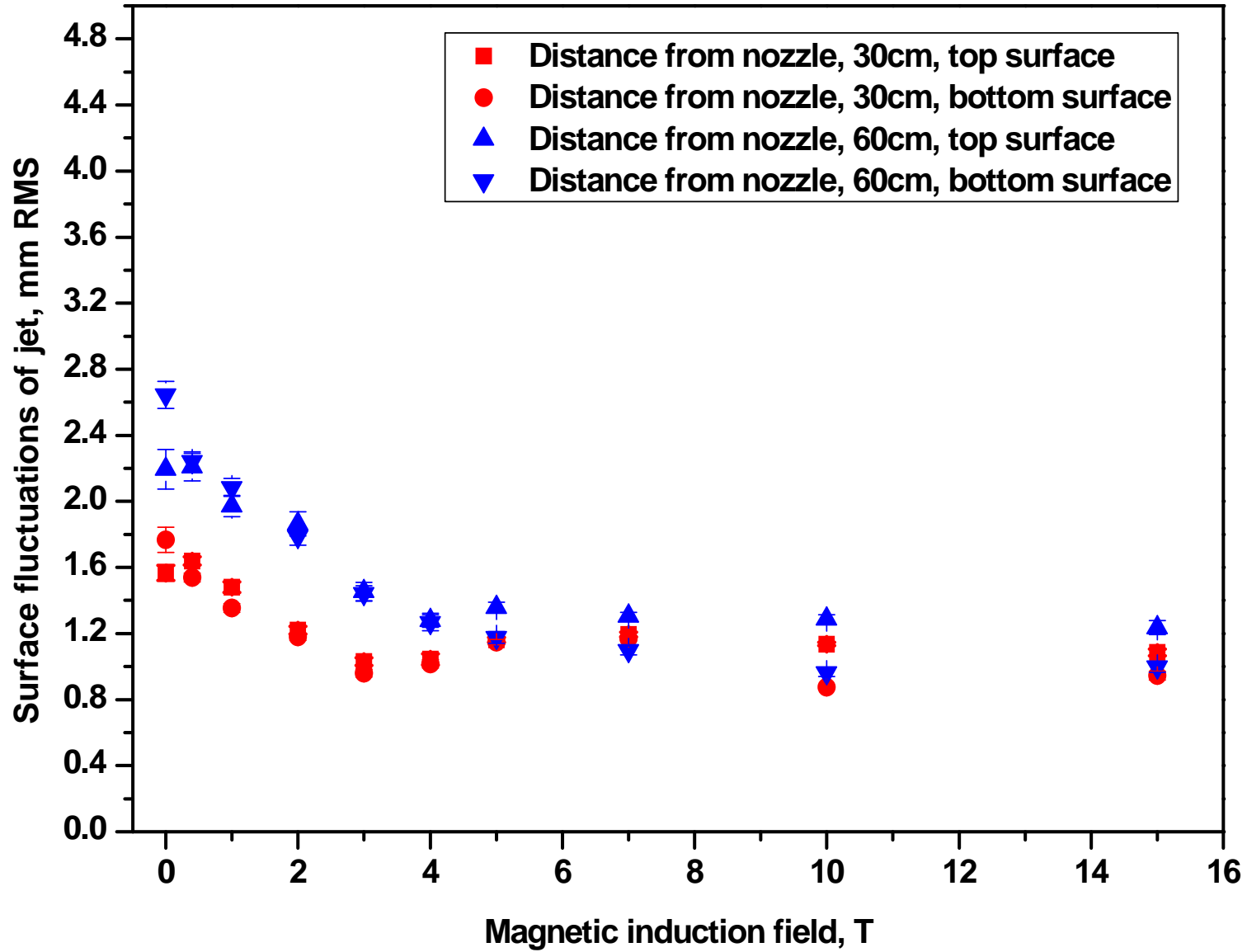

Results: Longitudinal Hg Jet Velocity In Magnetic Field, $V=15\text{m/s}$

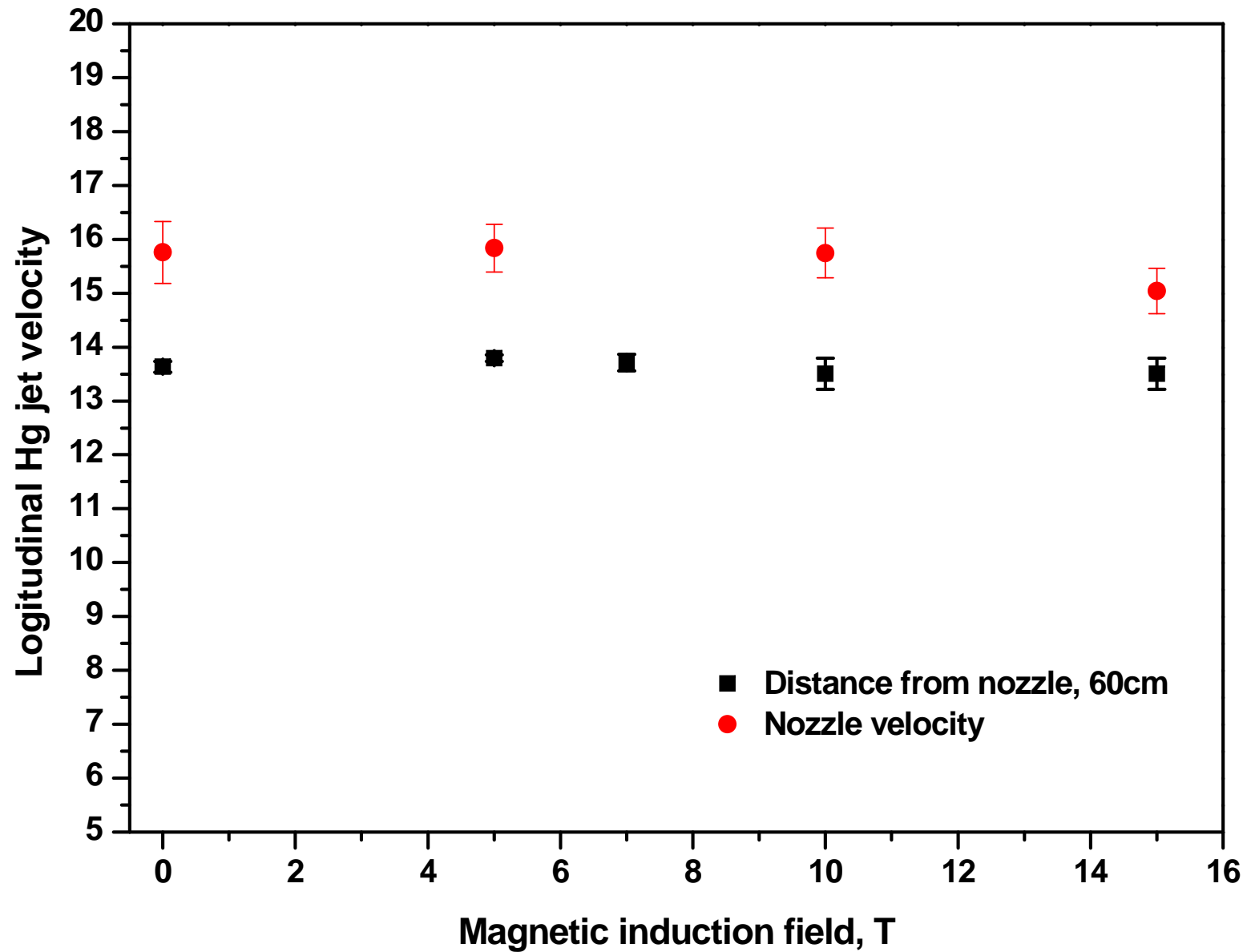

Results: Distributed Threshold, B=5T, 14GeV Proton Beam Program

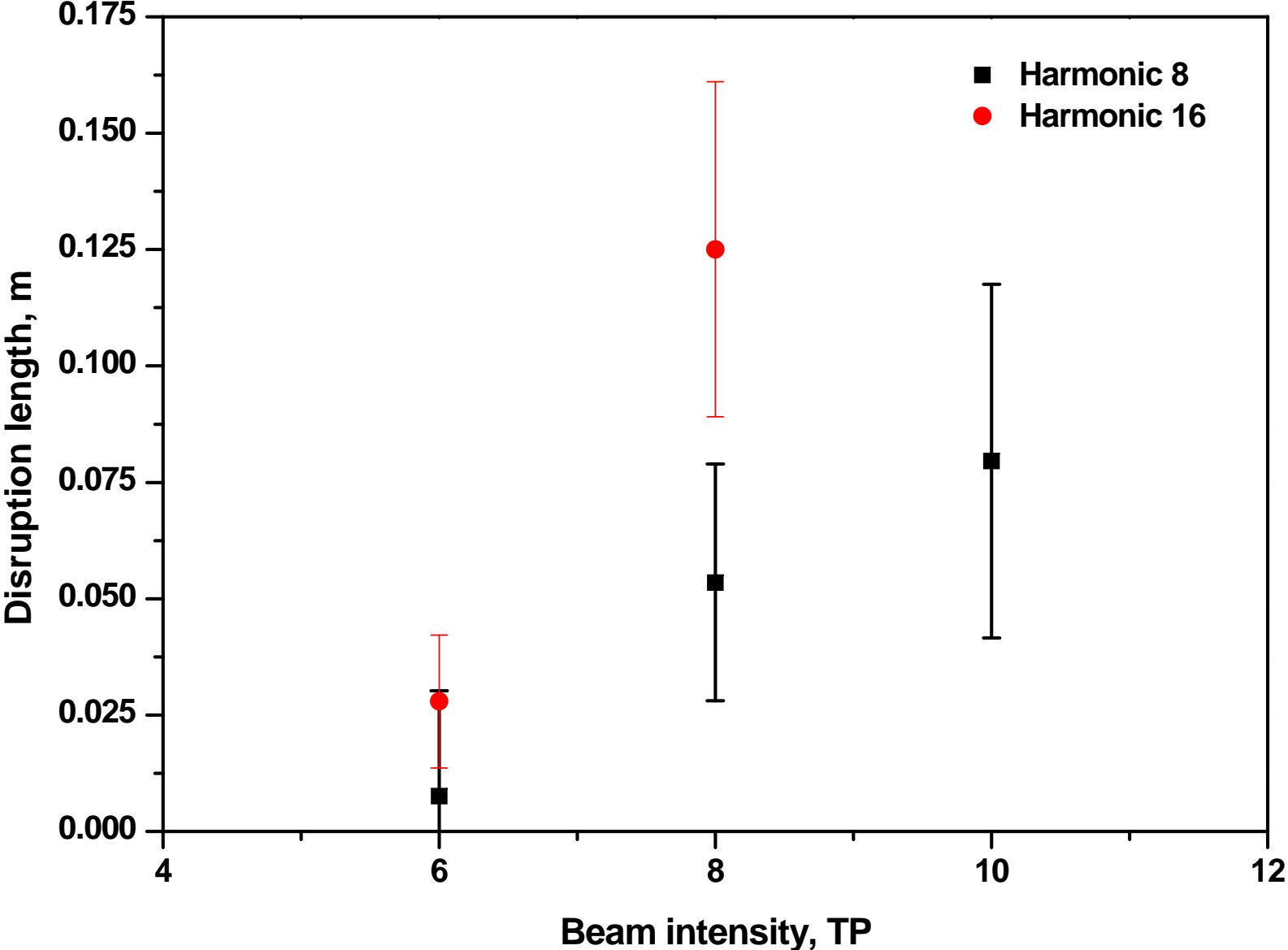

Results: Intensity Scan, Harmonic 16, 14GeV Proton Beam Program

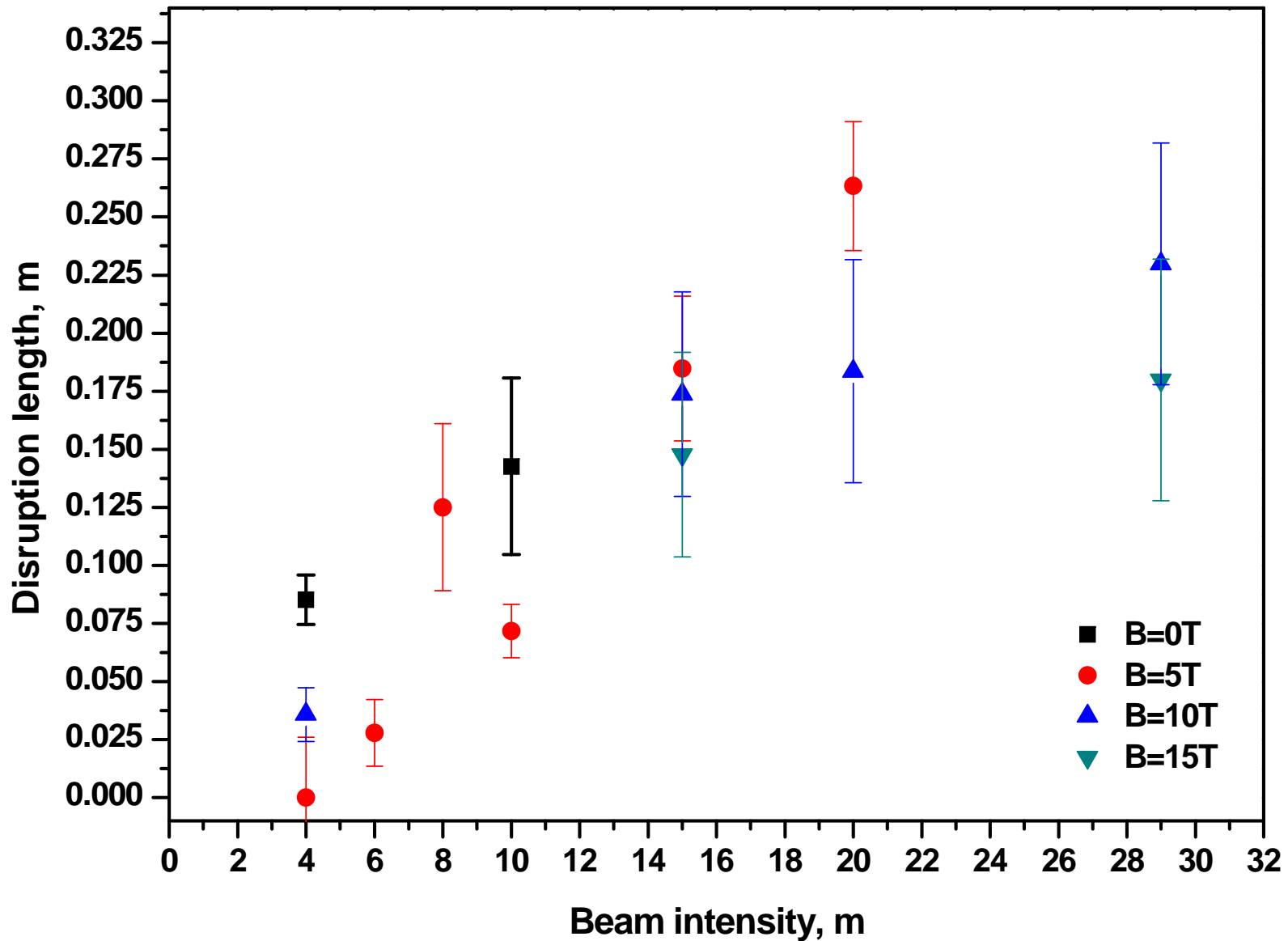

Results: Intensity Scan, Harmonic 16, 24GeV Proton Beam Program

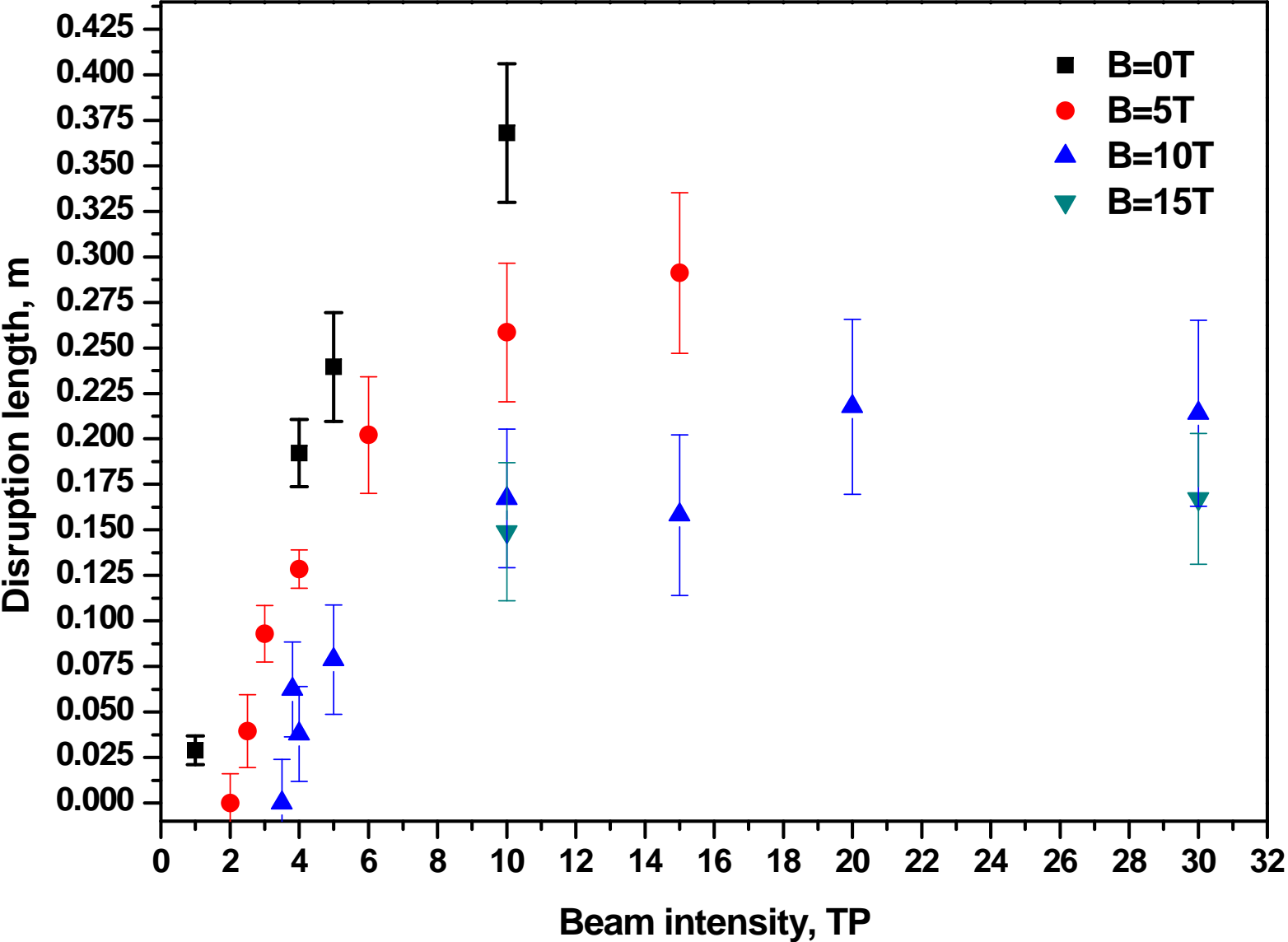

Results: Intensity Scan, 14GeV vs 24GeV Proton Beam

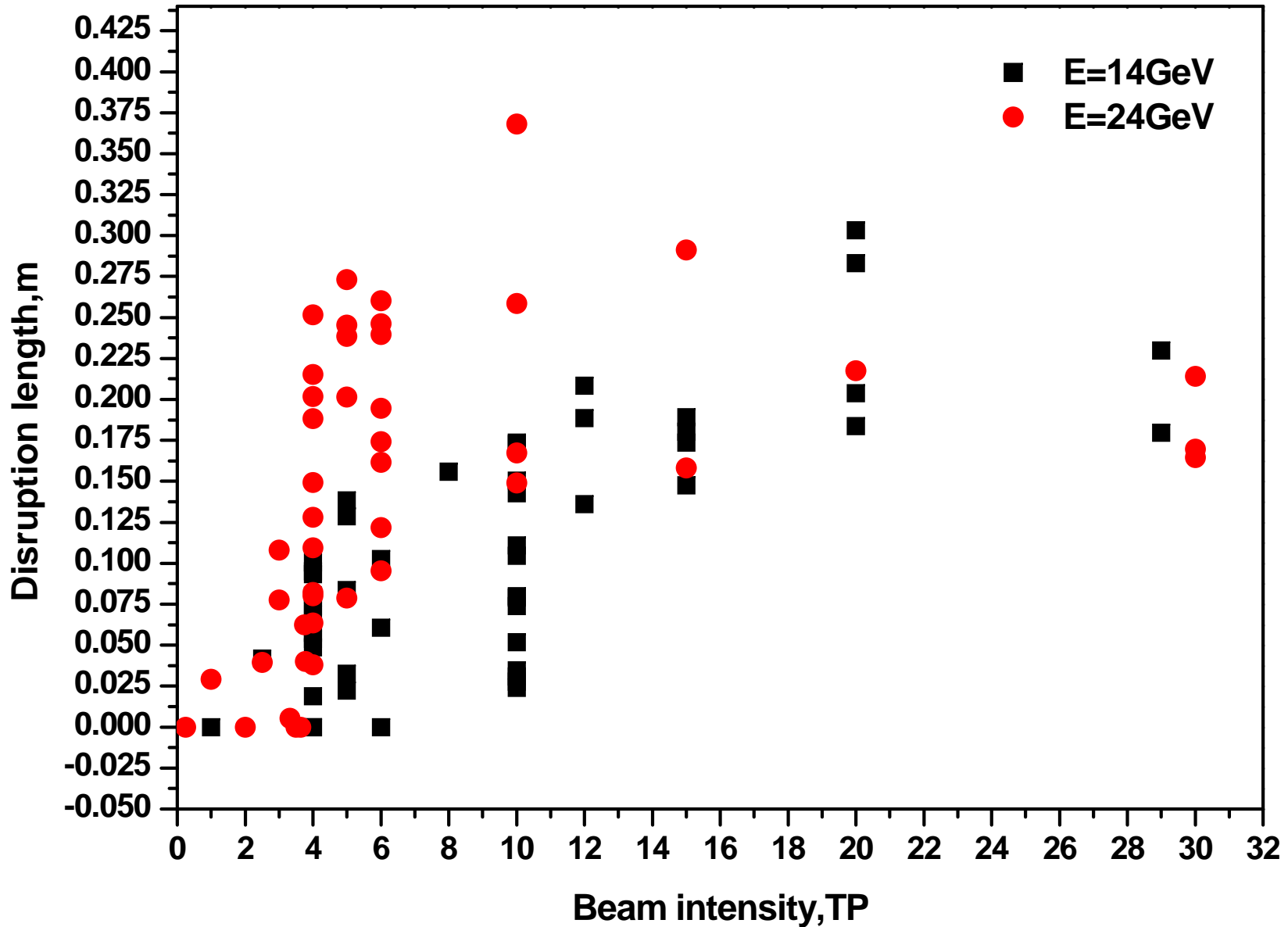

Conclusions

- 1. It is observed that the splash begins at the bottom of jet and ends at the top of jet, which is consistent with the beam trajectory. This breakup could be the by-product of cavitation caused by the energy deposition of the proton beam.**
- 2. The extent of the Hg jet breakup is influenced by the magnetic induction field.**
 - The splash velocity increases as the beam intensity increases, however, the magnetic induction field reduces the effect.**
 - The extent of the Hg jet disruption length is suppressed by the magnetic induction field.**
- 3. The 24GeV proton beam results in greater disruption length than the 14GeV proton beam. The intensity threshold for the 24GeV beam is lower than the 14GeV beam.**
- 4. The magnetic induction field stabilizes the Hg jet flow. The fluctuations on the jet surface decreases as the magnetic induction field increases.**
- 5. The jet size increases as it moves to downstream and it was same up to 10T but increases at 15T. The jet size at 10T was smaller than at 15T, which might be a result of B field induced elliptical distortion.**
- 6. The longitudinal Hg jet velocity was not significantly affected by the magnetic induction field.**