



Superconducting Magnets for the FRIB Fragment Separator

Al Zeller, Shailendra Chouhan, Rick Swanson,
Dan Cole

MICHIGAN STATE

UNIVERSITY



U.S. DEPARTMENT OF
ENERGY

Office of
Science

Outline

- History of rare isotope science at Michigan State University leads to FRIB
 - Unique FRIB framework: Cooperative Agreement for financial assistance
 - Fragment separator
 - Magnets
-
- Work supported by the U.S. Department of Energy Office of Science under Cooperative Agreement DE-SC0000661

Michigan State University

57,000 people; 36 sq mi; \$1.8B annual revenue; 552 buildings



Experimental Nuclear Physics at MSU

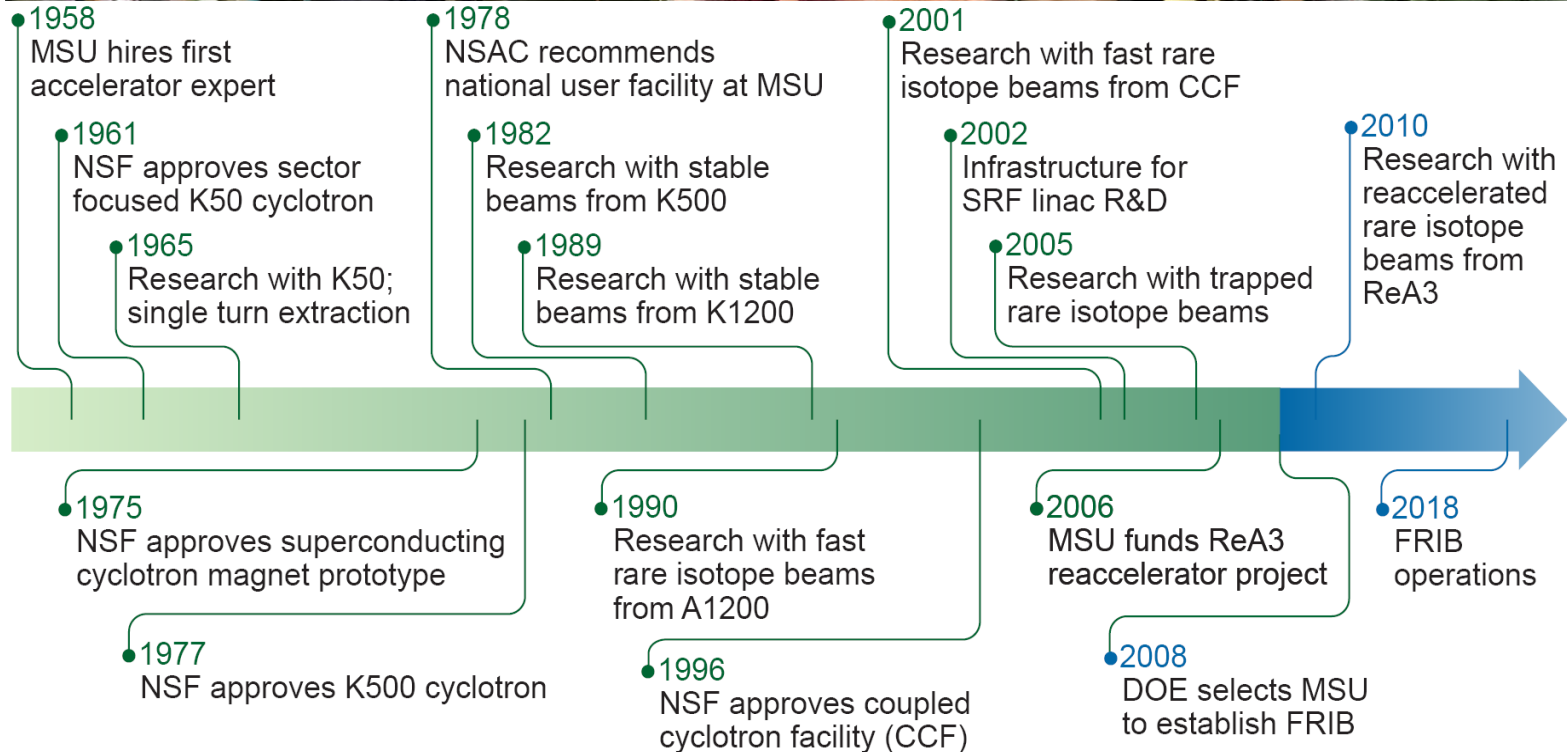

National Research Council RISAC Report

“The committee concludes that the science addressed by a rare-isotope facility, most likely based on a heavy ion linac driver, should be a high priority for the United States.” - NRC

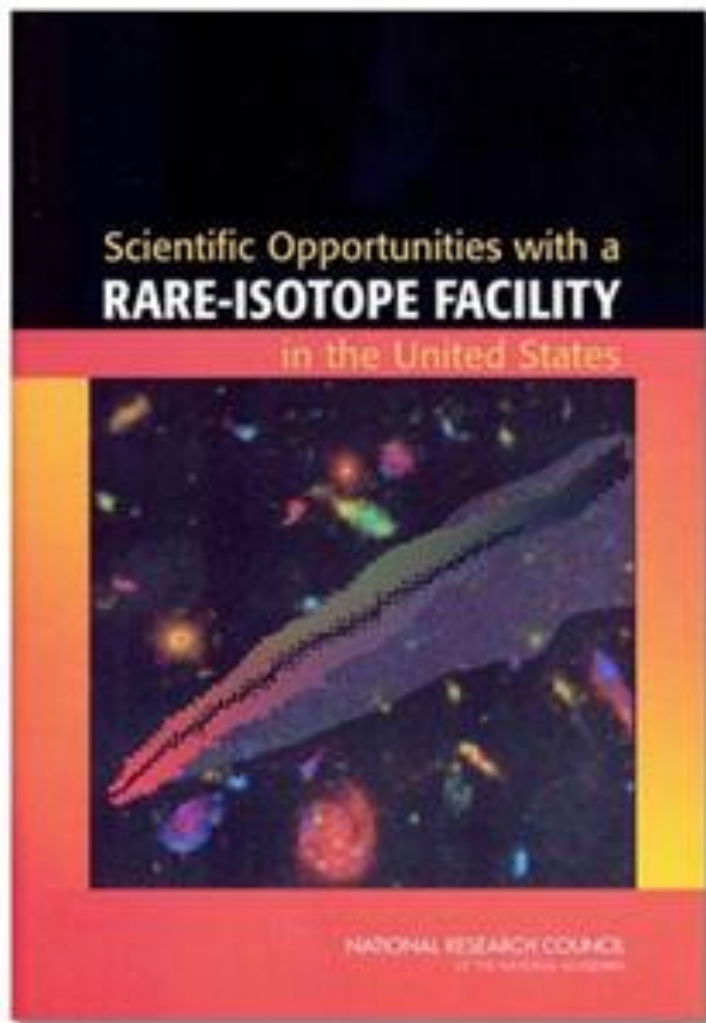

“ The committee concludes that nuclear structure and nuclear astrophysics constitute a vital component of the nuclear science portfolio in the United States. Moreover, nuclear structure-related research provides the scientific basis for important advances in medical research, national security, energy production, and industrial processing.”

“ The Gathering Storm report argued that strong public support of basic research can help fuel the national economic engine... While it is nearly impossible to argue that any one specific investment is critically necessary to maintain the future health of the enterprise, the committee does recognize the value of a U.S. FRIB as one element of a much broader portfolio in the physical sciences.”

—*Scientific Opportunities with a Rare Isotope Facility, December 2006*

1A QB-002

FRIB



Facility for Rare Isotope Beams
U.S. Department of Energy Office of Science
Michigan State University

FRIB – a DOE-SC National User Facility Enabling Scientists to Make Discoveries

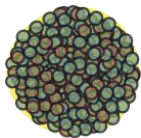

Properties of nucleonic matter

- Classical domain of nuclear science
- Many-body quantum problem: intellectual overlap to mesoscopic science – how to understand the world from simple building blocks

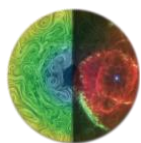

Nuclear processes in the universe

- Energy generation in stars, (explosive) nucleo-synthesis
- Properties of neutron stars, EOS of asymmetric nuclear matter

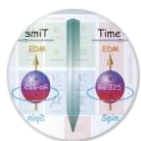

Tests of fundamental symmetries

- Effects of symmetry violations are amplified in certain nuclei

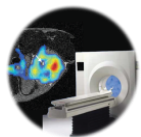

Societal applications and benefits

- Bio-medicine, energy, material sciences, national security

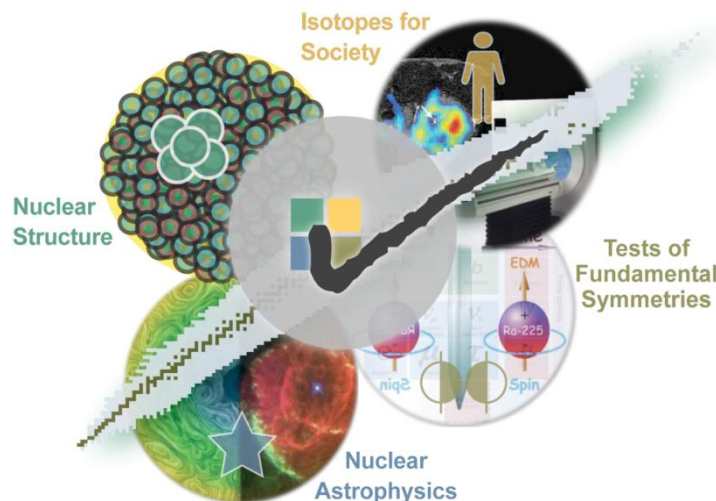

Major Configuration Alternatives Considered

✓ = chosen ✗ = not chosen

✗ Straight configuration

✗ Folded configuration

✓ Double-folded configuration

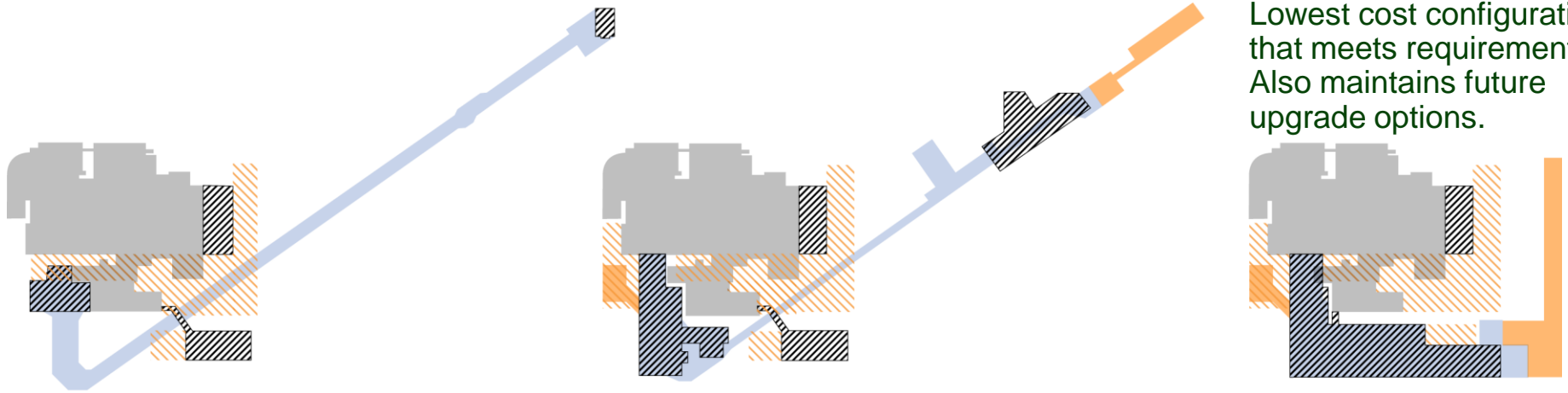

Lowest cost configuration that meets requirements. Also maintains future upgrade options.

200 FT
50 M

Existing

New Underground

New Surface

Upgrade Underground

Upgrade Surface

All configurations meet requirements: ≥ 200 MeV/u, 400 kW for all ions; fast, stopped, reaccelerated beams; support infrastructure; space for 100 users at a time; world-class science program at start of operations

Future upgrade options for all configurations: Space to double experimental area; ISOL addition; Light-ion injector addition; multi-user option addition

Future energy upgrade options

≥ 400 MeV/u for all ions with baseline $\lambda/2$ cryomodules

≥ 400 MeV/u for all ions with baseline $\lambda/2$ cryomodules

≥ 400 MeV/u for all ions with high-performance cryomodules (35% gradient increase over baseline cryomodules)

Civil Design Complete & Integrated with Technical Systems



Early Science Opportunities with Fast, Stopped, and Reaccelerated Beams

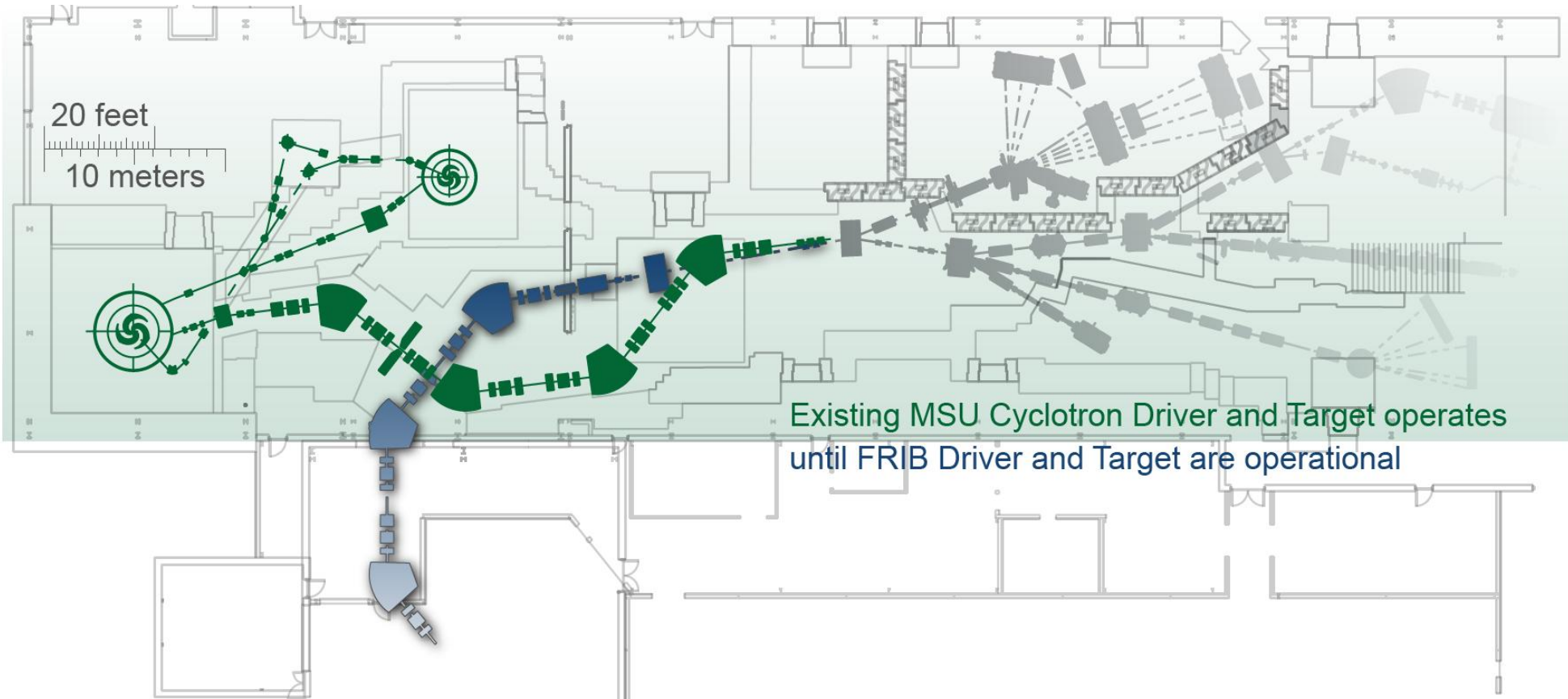

- Collaborations form early while FRIB is being constructed
- Post-production elements commissioned before FRIB driver linac complete
- Ensures world-class scientific research program at start of FRIB operation

CD-4 Performance Parameters

System	Parameter	Performance Criteria
Accelerator System	Accelerate multiple charge states of a heavy ion beam of ^{86}Kr	Measure FRIB driver linac beam w/ energy > 200 MeV/nucleon & beam current >20 pA
Experimental System	Produce a fast rare isotope beam of ^{84}Se	Detect & identify ^{84}Se isotopes in FRIB fragment separator focal plane
	Stop a fast rare isotope beam in gas and reaccelerate a rare isotope beam	Measure reaccelerated rare isotope beam energy > 3 MeV/nucleon
Conventional Facilities	Linac tunnel	Beneficial occupancy of subterranean tunnel of ~ 500 feet path length (minimum) to house FRIB driver linear accelerator
	Cryogenic helium liquifier plant—bldg & eqmt	Beneficial occupancy of the CHL plant bldg and installation of CHL plant complete
	Target area	Beneficial occupancy of target area and once beam line installed and ready for commissioning

Upgrade Options for Preferred Alternative

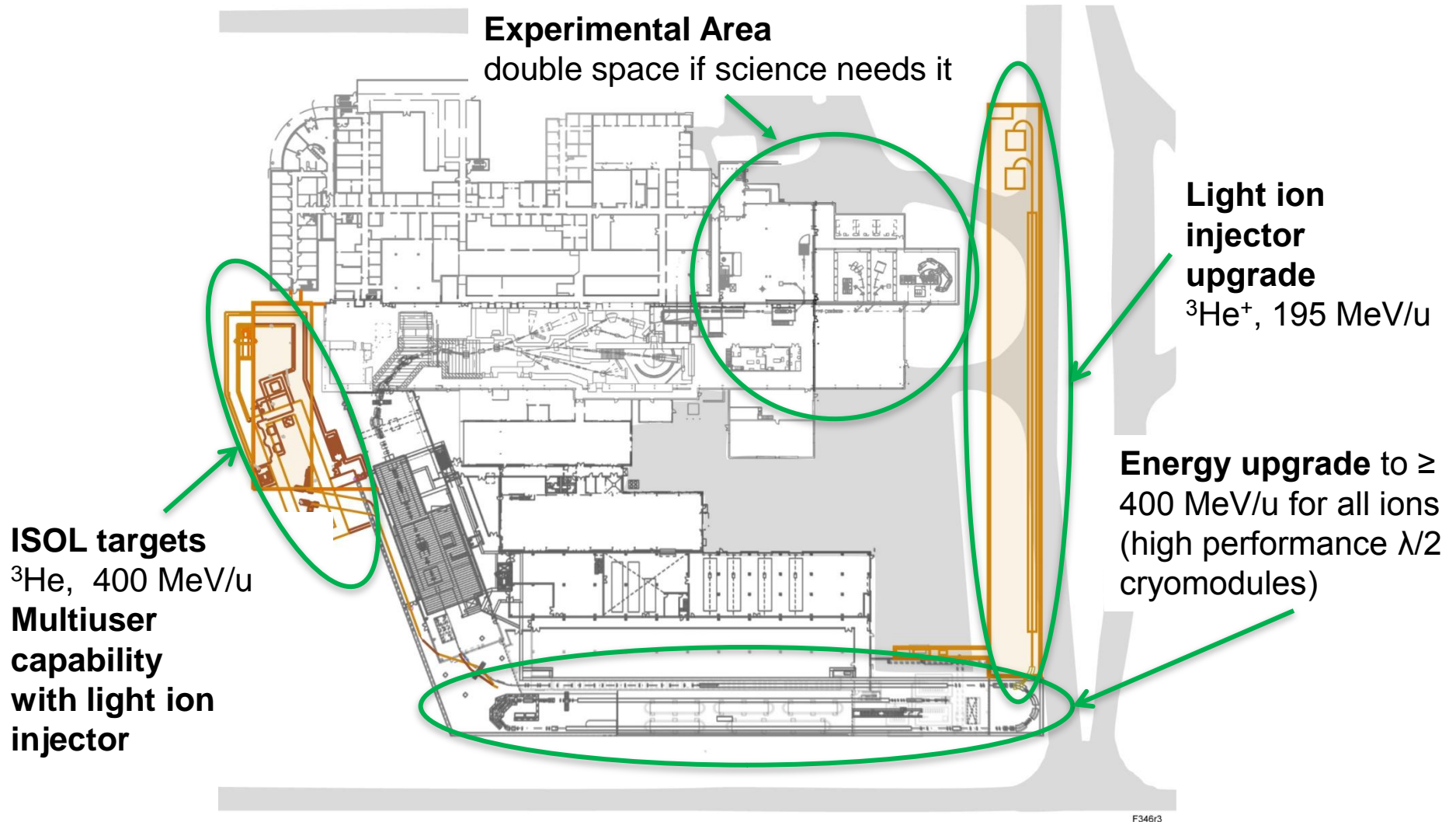

Target Facility Alternative Chosen

✓ = chosen ✗ = not chosen

Common target building for in-flight and ISOL beam production. Compatible with V1 separator.

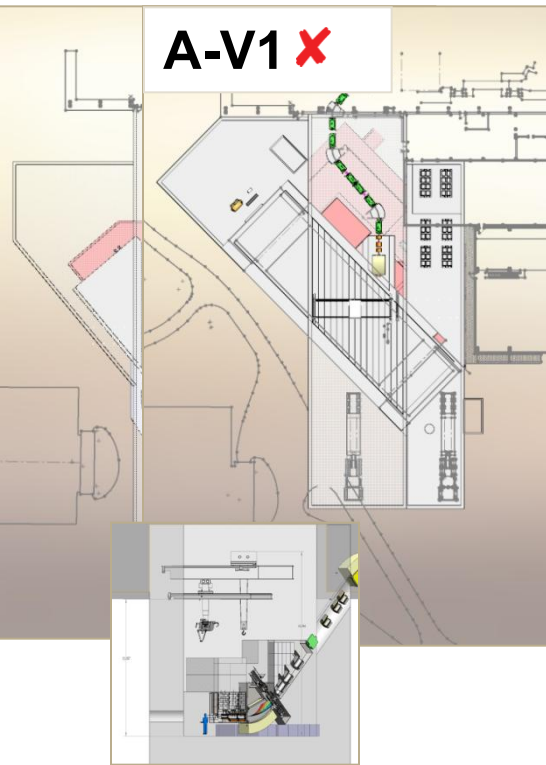

Common target building for in-flight and ISOL beam production. Compatible with V2 separator.

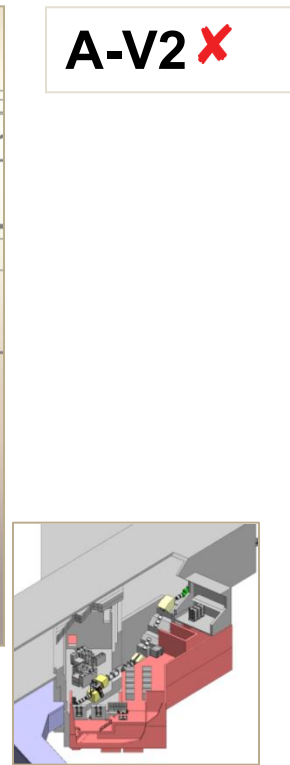

Common target building for in-flight and ISOL beam production. Compatible with H1 separator.

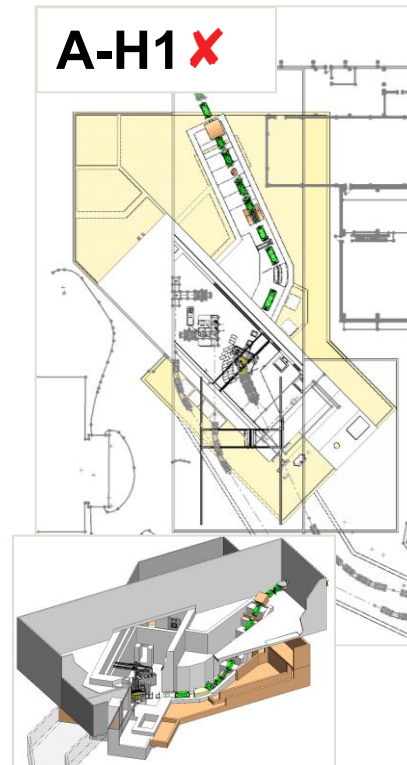

Single target building for in-flight production only. Compatible with V2b separator. Provides ISOL upgrade path.

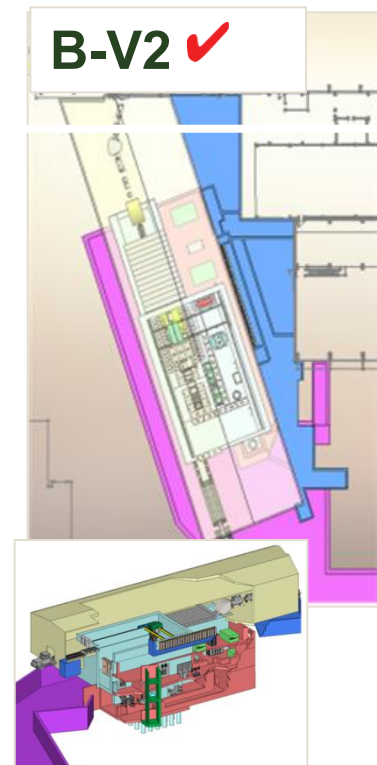

B-V2 is chosen alternative: lowest-cost option with best performance for baseline requirements

Preseparator Beam Optics Design Optimization for Maximum Science

- Space for 2nd beam dump included in design
 - Increased dispersion and resolving power enable selection of rare isotope between charge states of primary beam
 - Large gain factors where alternative is to use weak rare isotope charge state
 - Most applicable for heavy primary beams, namely for uranium
 - Second beam dump option fully integrated in the ion-optical design, main driver to increase dipole bend angles to 30 degrees

Yield gain for specific isotopes with 2nd beam dump

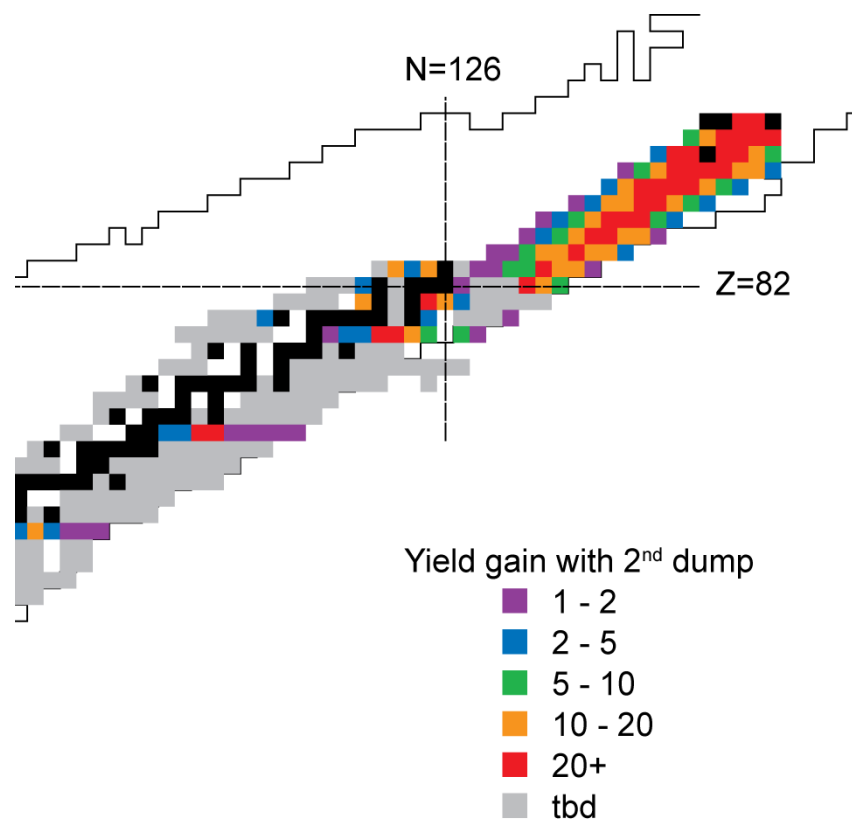

Preseparator Beam Optics

Versatile Design Supports Multiple Operational Modes

- Combination of multiple modes maximizes covered science range
- Image at beam dump 1
 - Optimized for rare isotopes far from stability
 - Maximum momentum acceptance
 - » Compressed by factor of 3
 - Maximum magnetic rigidity of 8 Tm
 - Trajectories shown in 5th order with aberration correction
- Image at beam dump 2 (upgrade option)
 - Optimized for heavy rare isotopes near stability
 - Selection of rare isotope beam between primary beam charge states
 - Enhanced dispersion/resolving power at beam dump
 - Trajectories shown in 5th order

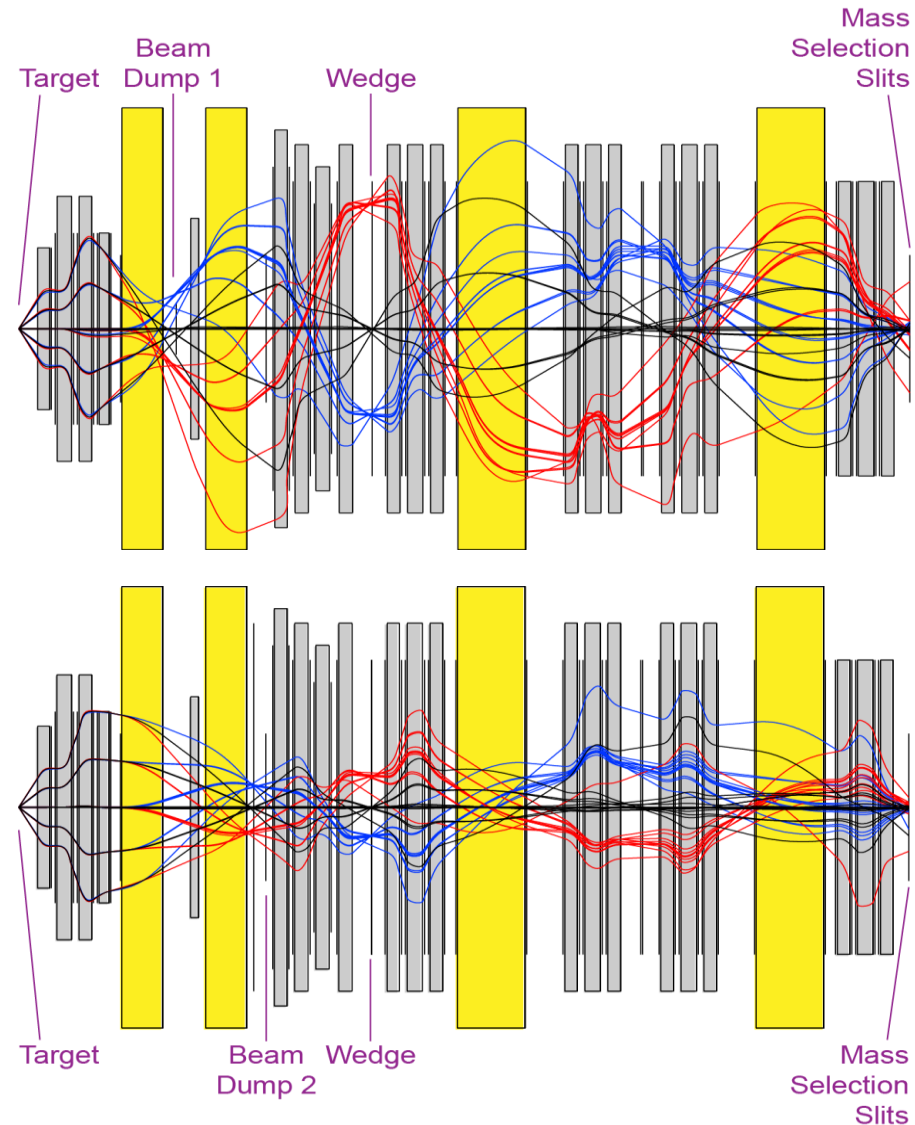

Overview Experimental Systems

Fragment Separator

■ Scope

- In-flight separation of rare isotopes with high acceptance and high resolution
 - » Leverage rare isotope production at 400 kW beam power
 - » Provide purest-possible rare isotopes beam to maximize science reach

■ Technical specifications

- High-acceptance preseparator provides first beam purification step, provides defined location(s) for primary beam dump
- 2 additional separation stages to guarantee high beam purity
- Provide future upgrade opportunities for isotope harvesting

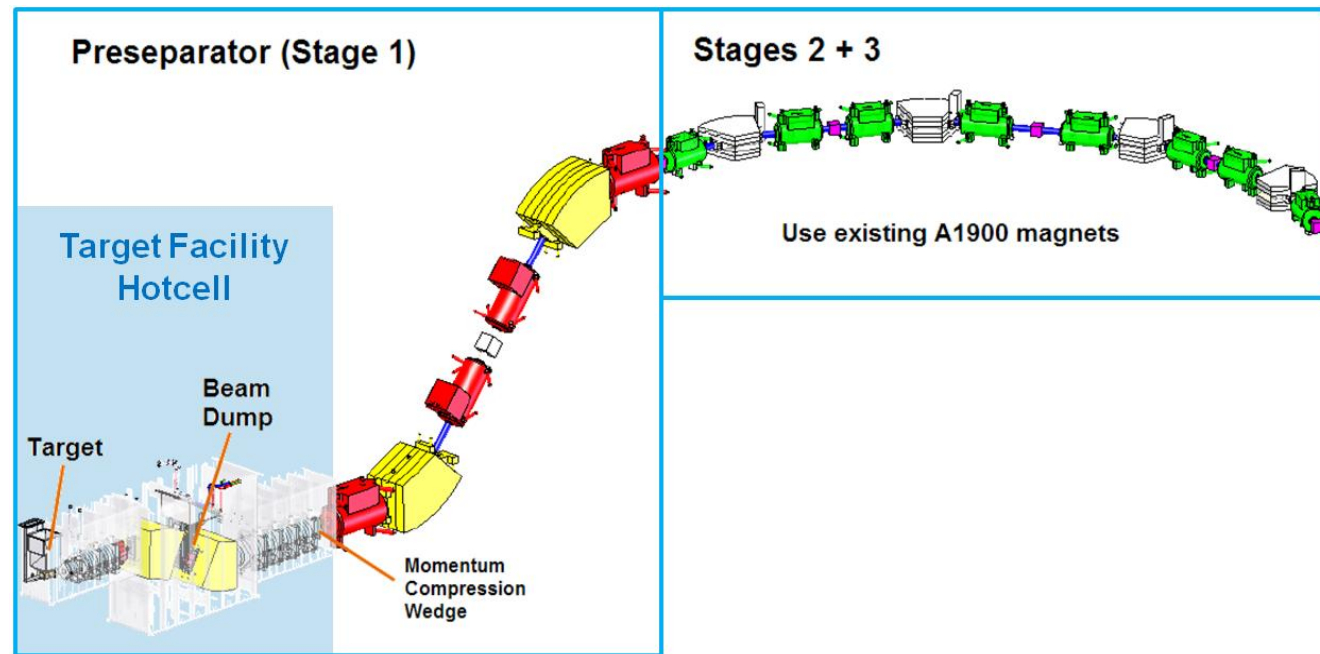

Carbon Disk / Heat Exchanger Approach

- Multi-slice target test assembly (5 slices shown)
- Sized for 50 to 70 kW dissipated power
- Dimensionally, functionally, and mechanically very similar to operational assembly

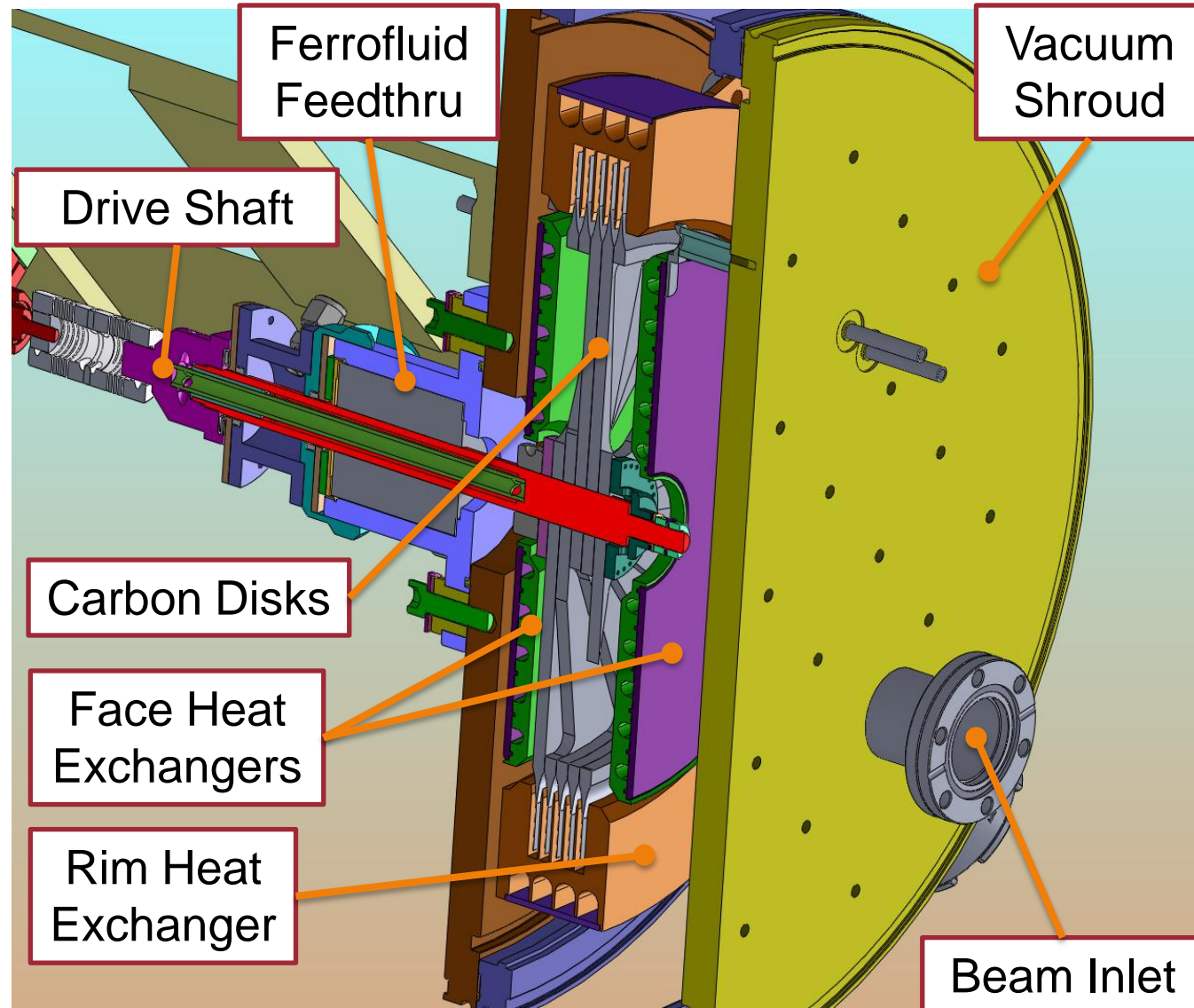

Target Assembly

- Target speed requirement
 - 5,000 rpm disk rotation – needed to prevent overheating of carbon disks
- Water cooled HX, subject of ongoing design validation efforts
 - Allows rapid extraction of heat from beam interaction with target disks
- 1 mm positioning tolerance
- Remotely serviceable/
replaceable from lid
- Sufficient space available to accommodate future target designs (incl. liquid metal)
 - 1.5 m cube available
 - Standard types of utilities provided (power, signal, water, air)

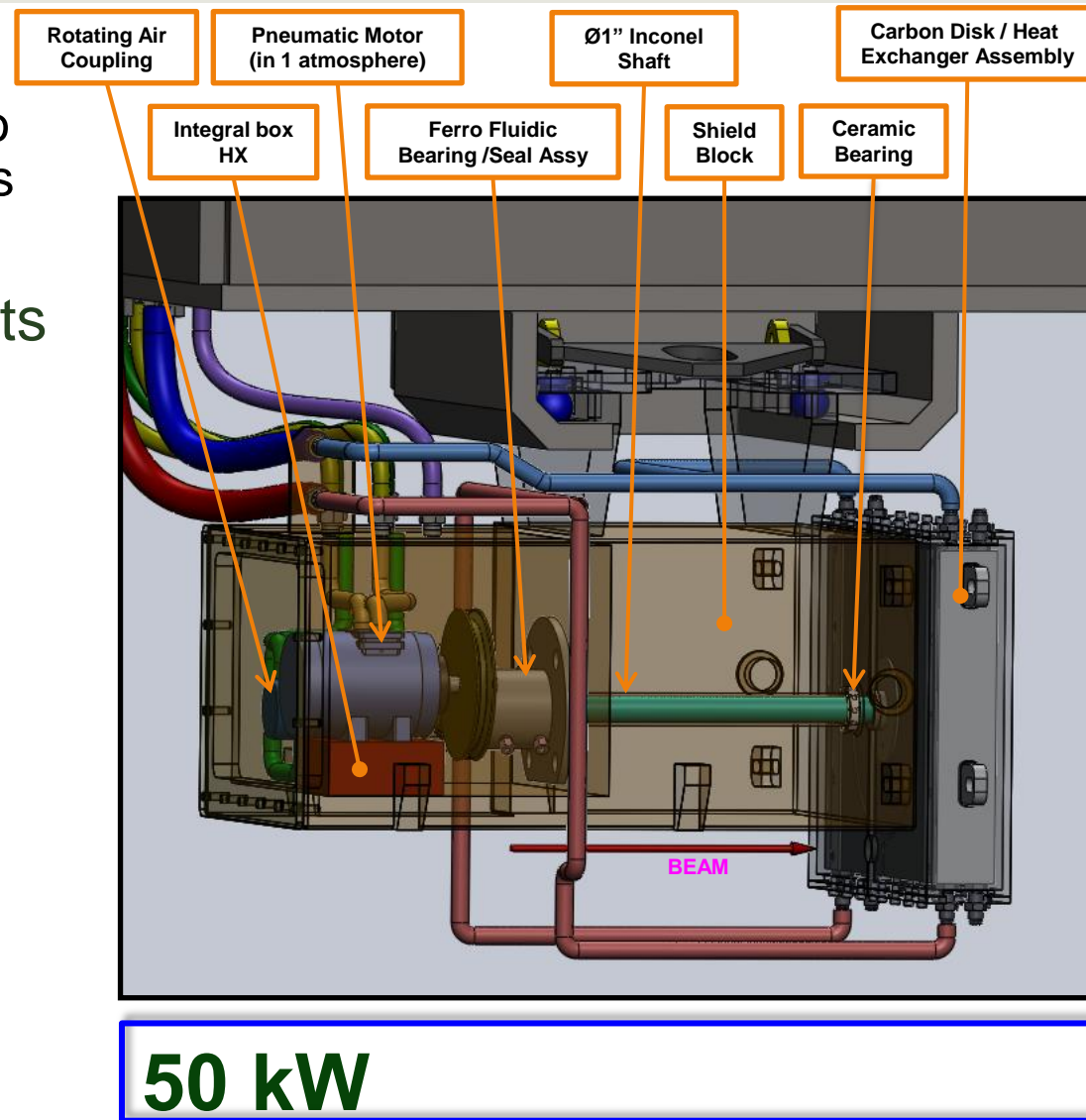

Target Assembly

- Compact fully integrated target design approach adopted
- Shielded motor in one atm pressurized enclosure
- Shaft powers target wheel through ferrofluid vacuum feedthru
- Target rests on kinematic mounts that provide automatic positioning after target module changes

Present Configuration

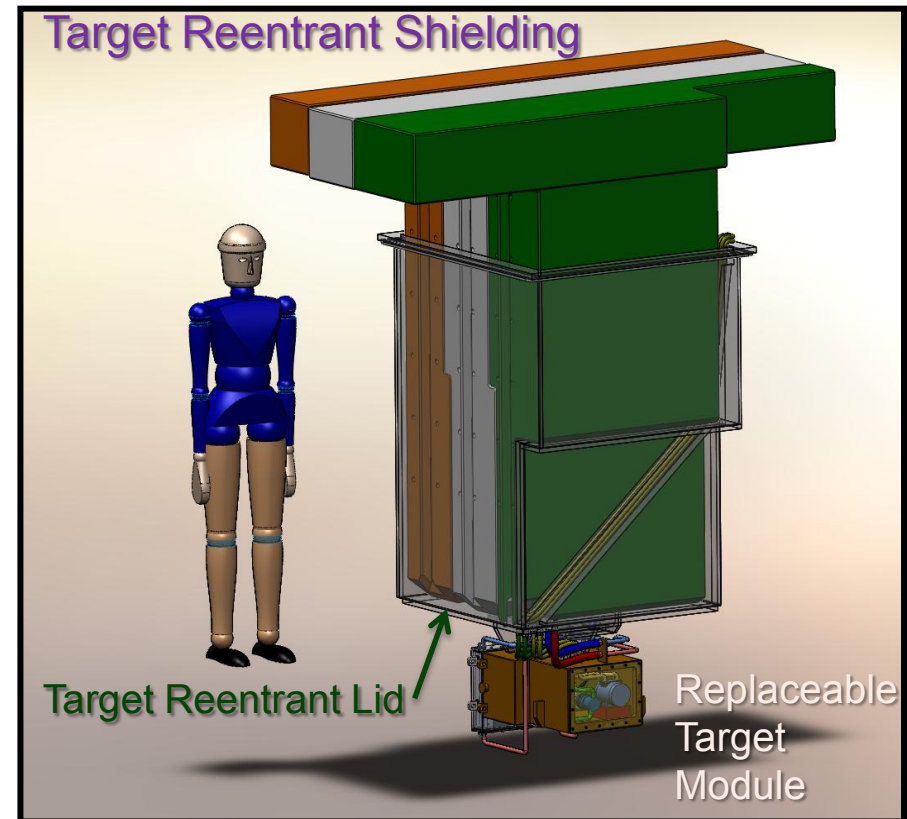

Overview Experimental Systems [1]

Target Facility T.4.02/T.4.04

■ Scope

- High-yield production of rare isotopes via in-flight production with light and heavy primary beams (400 kW, >200 MeV/u)

■ Technical specifications

- Self-contained target building
 - » Keep most-activated and contaminated components in one spot
- State-of-the-art remote handling
 - » Fast and safe target changes
- Target applicable to light and heavy beams
 - » Minimize number of target technologies needed
- Flexible upgrades, fast implementation
 - » Design for 400 kW 400 MeV/u uranium energy upgrade
 - » Facility design compatible with future upgrades by implementing ISOL and multi-user capability

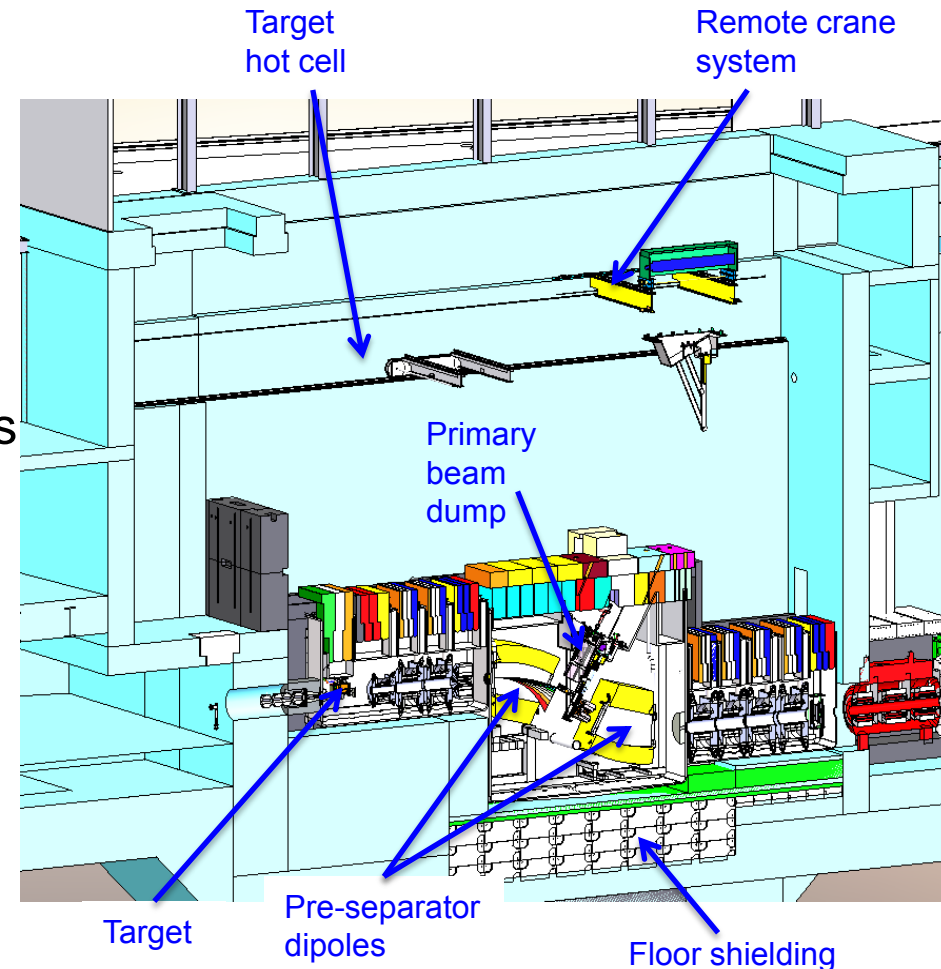

Beam dump

- **Water-filled rotating drum selected for FRIB baseline**
- **Risks: high power density, radiation damage**
 - Several alternatives studied
 - » Rotating water-filled dump
 - » Rotating graphite dump
 - » Windowless liquid metal dump
 - Rotating water-filled dump selected for FRIB baseline
- **Technical risks largely retired, residual risks acceptable and mitigation in place**
 - Thermal and hydrodynamic studies, materials evaluation, radiation damage assessment
- **Mechanical mockup for rotating drum for design validation designed and under construction**

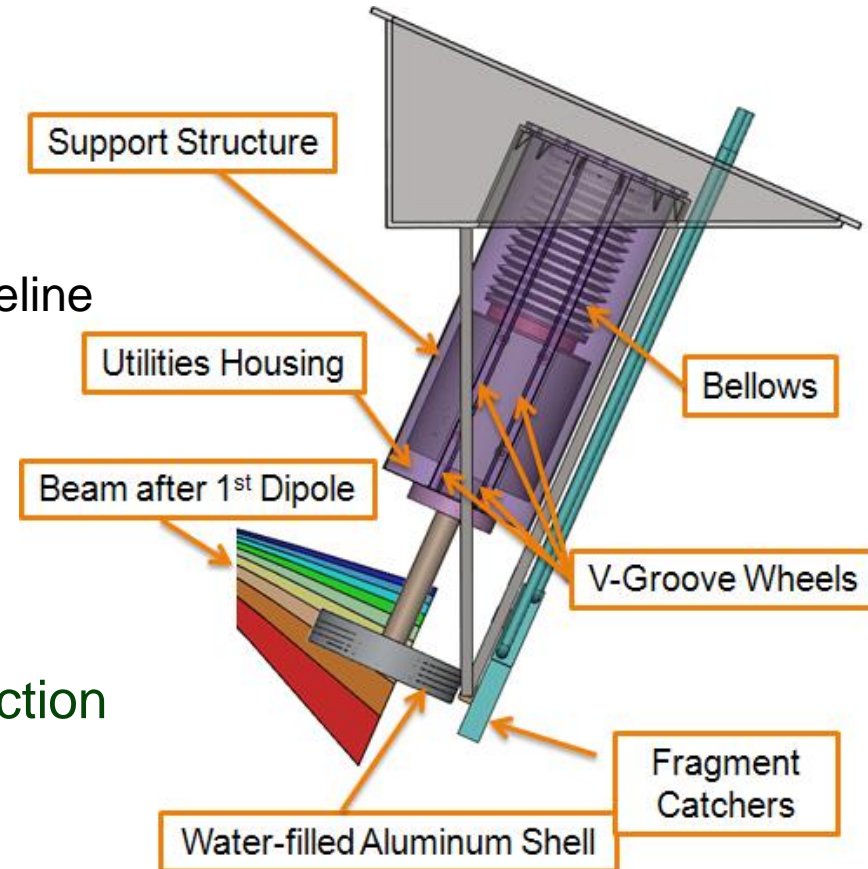

RH Considered in Component Design

Example: Beam Dump

- Beam dump assembly is composed of a structural frame, beam dump module with rotating water cooled drum, and fragment dump module
 - One of the largest and more complex components remotely handled
 - Modularized
 - Total weight: 23,000 lbs

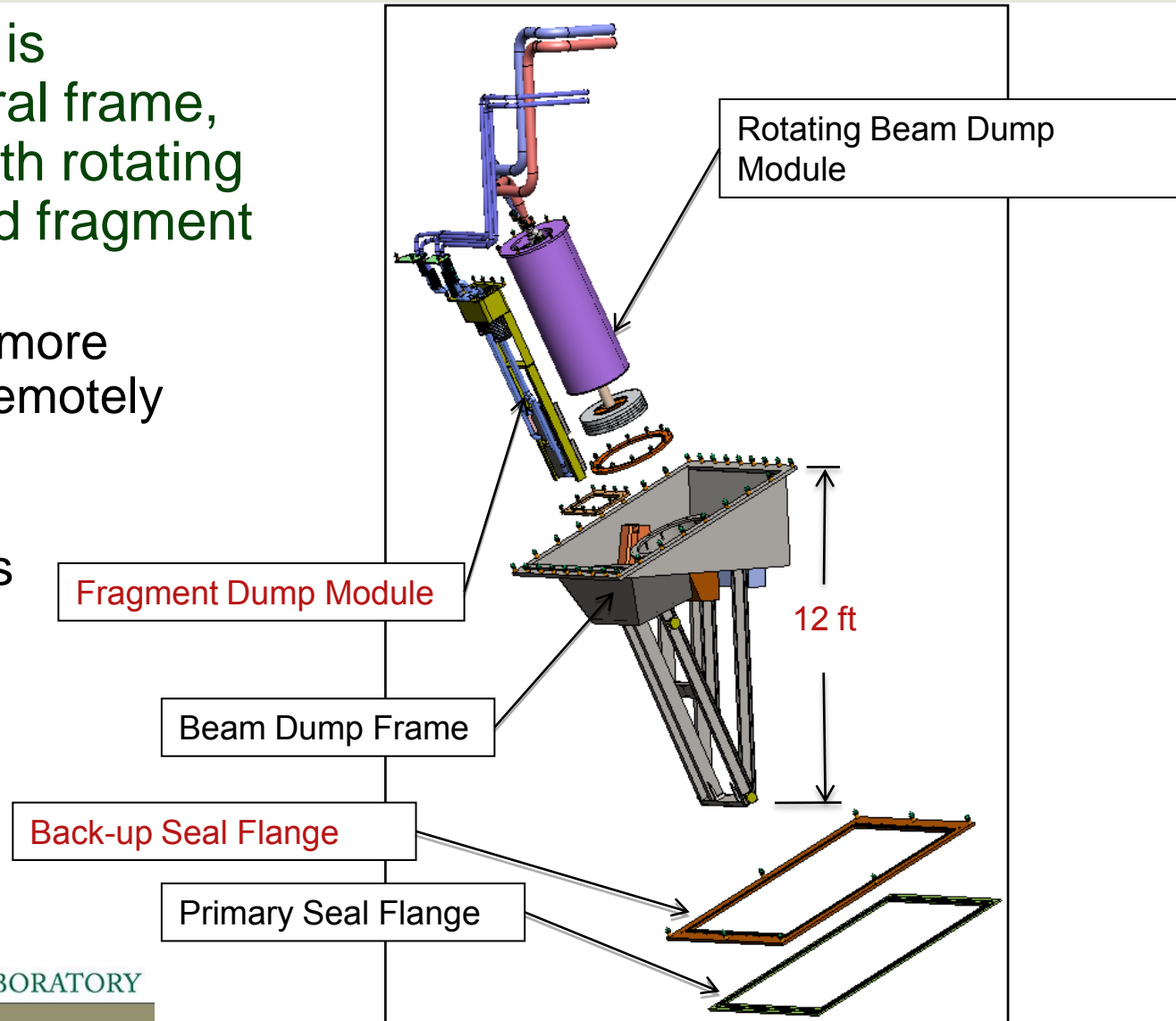

Remote Handling Concept Defined

Example: Beam Dump

- Remote beam dump removal
 - Shielding is remotely removed and stored using in-cell crane
 - Beam dump assembly removed using in-cell crane with multi-axis coordinated motion
 - Removal of beam dump with a vertical trajectory was evaluated and determined to be not feasible

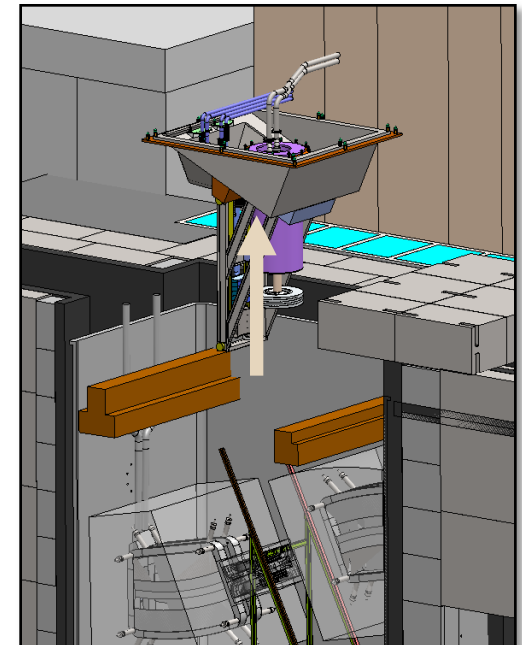
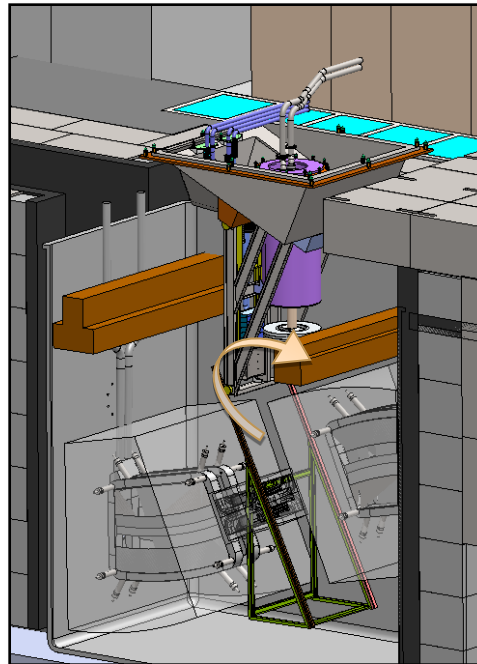
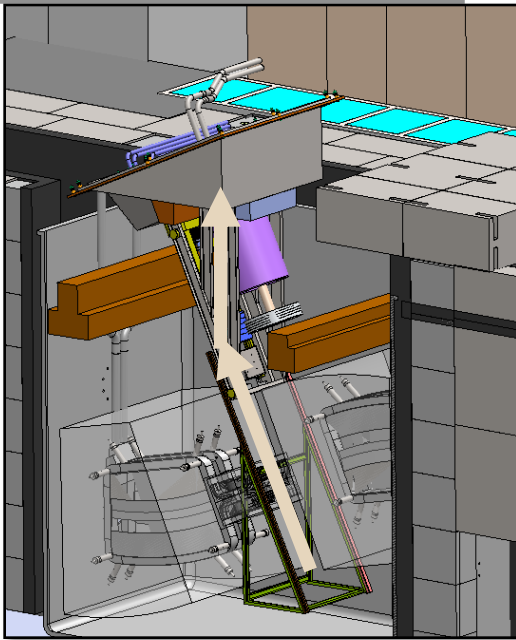
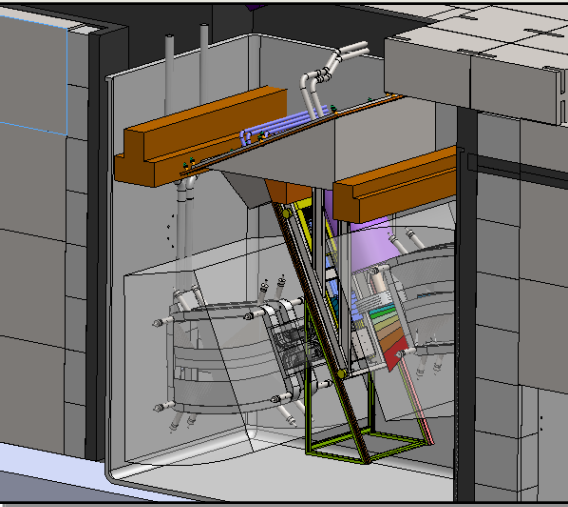

Fragment Separator Component Overview

Magnets to be Designed and Built

- MSU has many years experience in designing superconducting and resistive magnets
- Magnet mechanical design concepts are well established

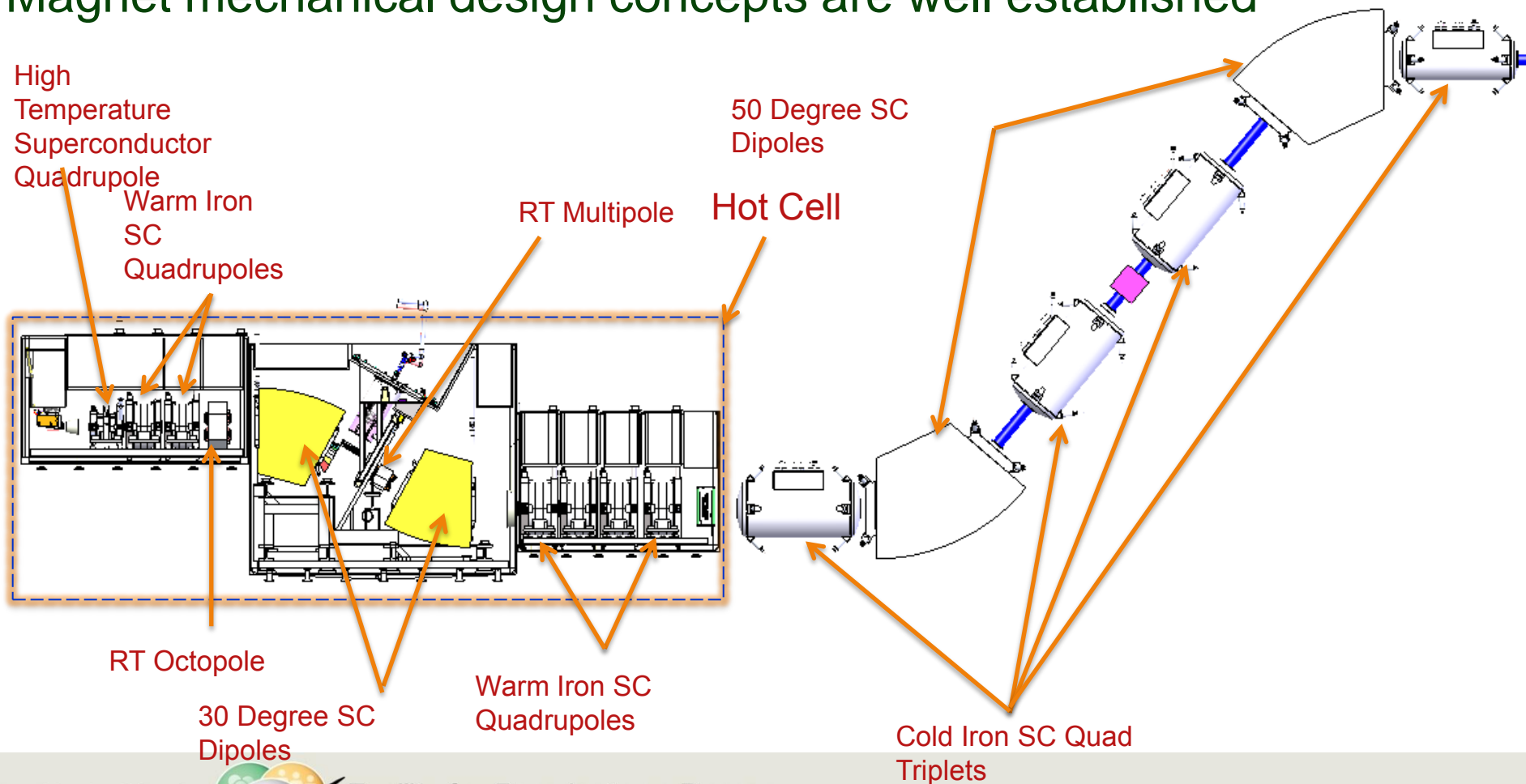

Assumptions

- Five year ramp to full 400 kW
 - Use radiation tolerant coils (cyanate ester)
 - Use HTS for first quad after target (BNL – see talk by Ramesh Gupta)
 - Use HTS for two dipoles in hot cell
- All magnets have to be replaceable using remote handling

Fragment Separator Magnet Design Process

Beam Physics Requirements



Magnetostatic Requirements



**Remote Handling
Requirements in Hot Cell**



Mechanical Design

Warm iron quad (half)

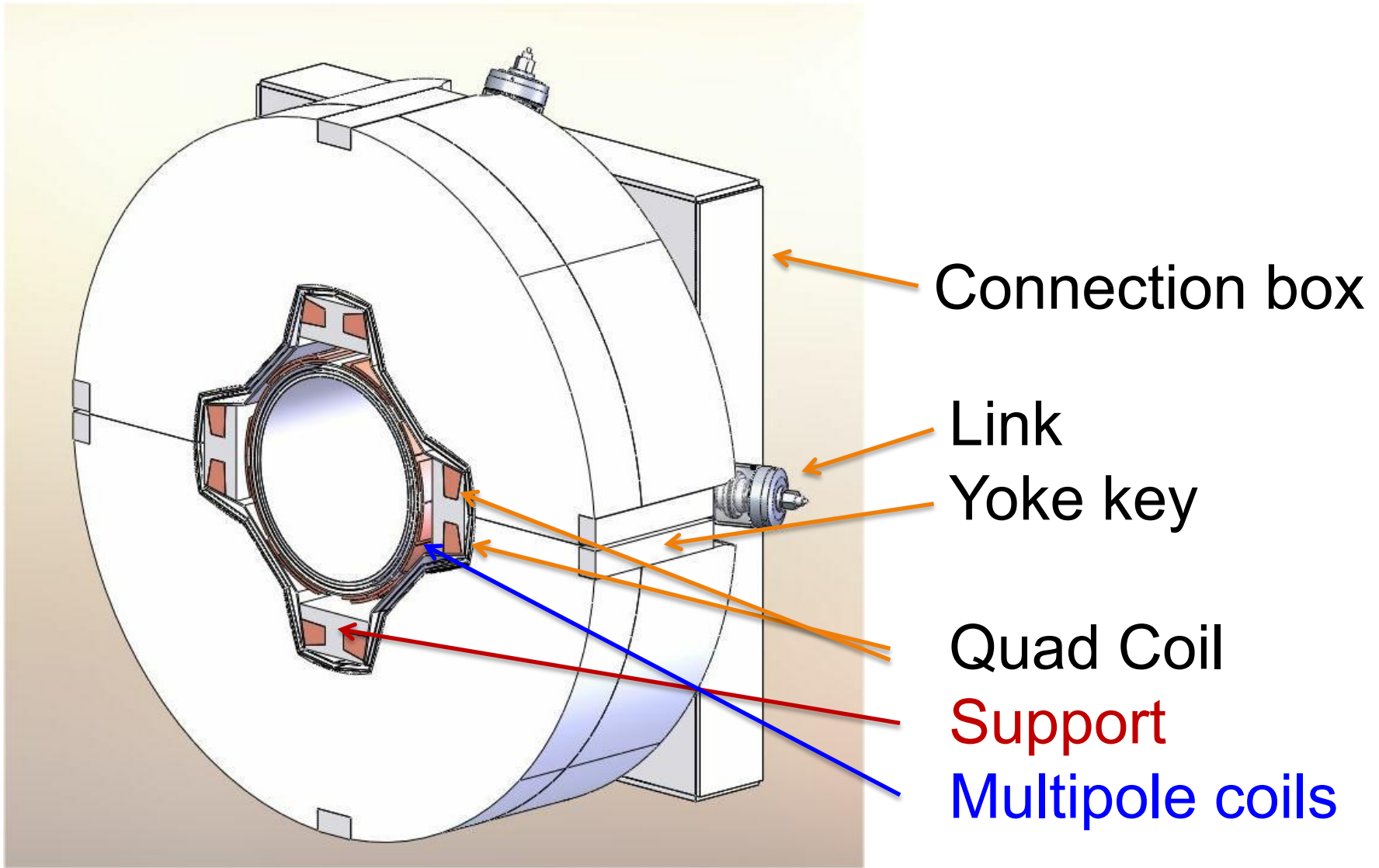

Warm iron quad(2)

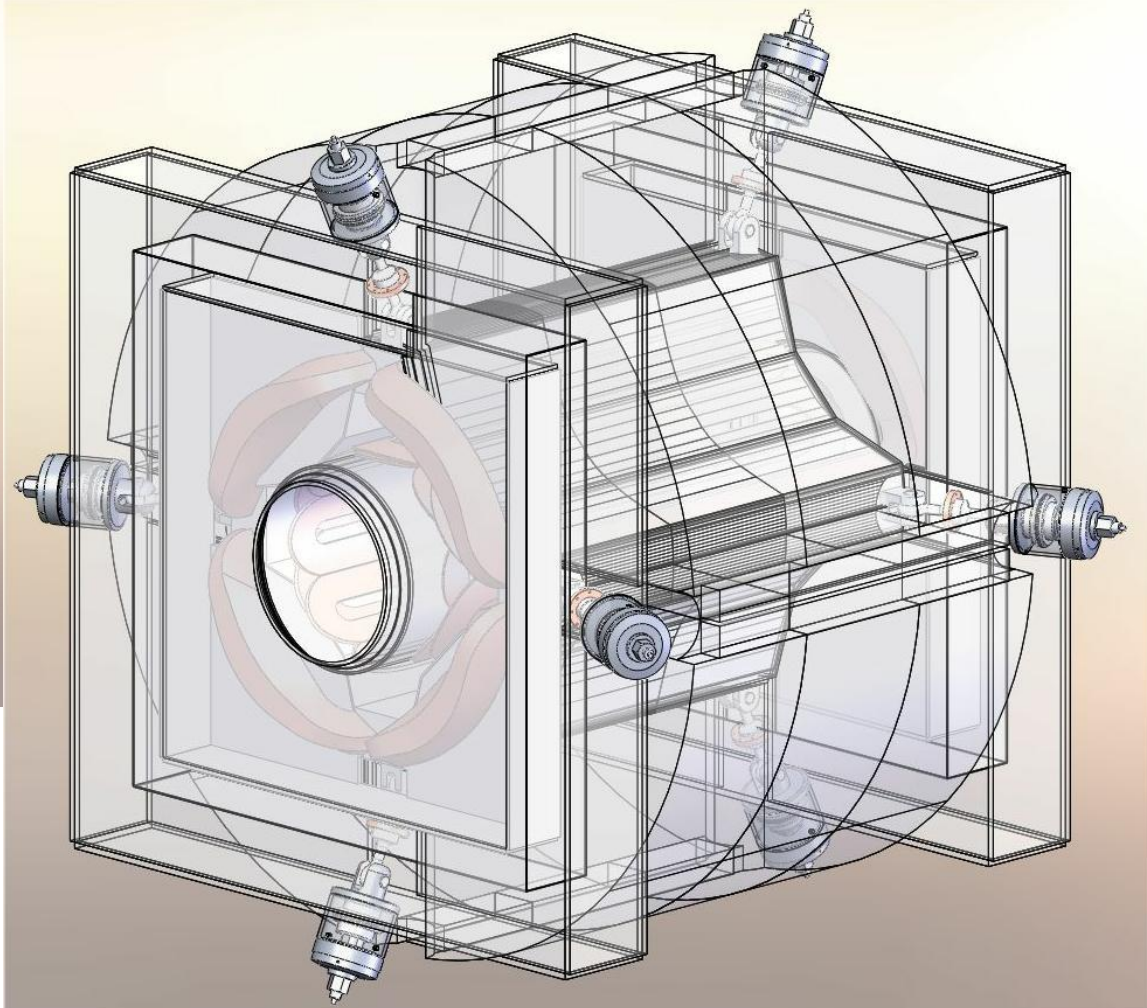
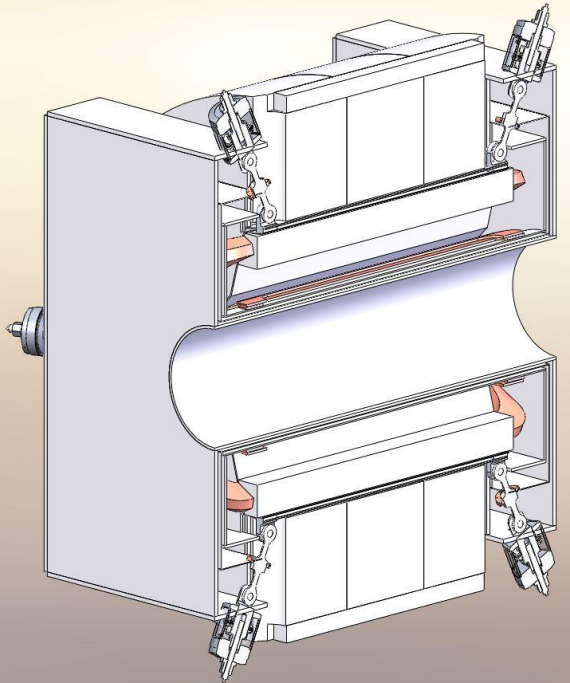

30 degree dipole

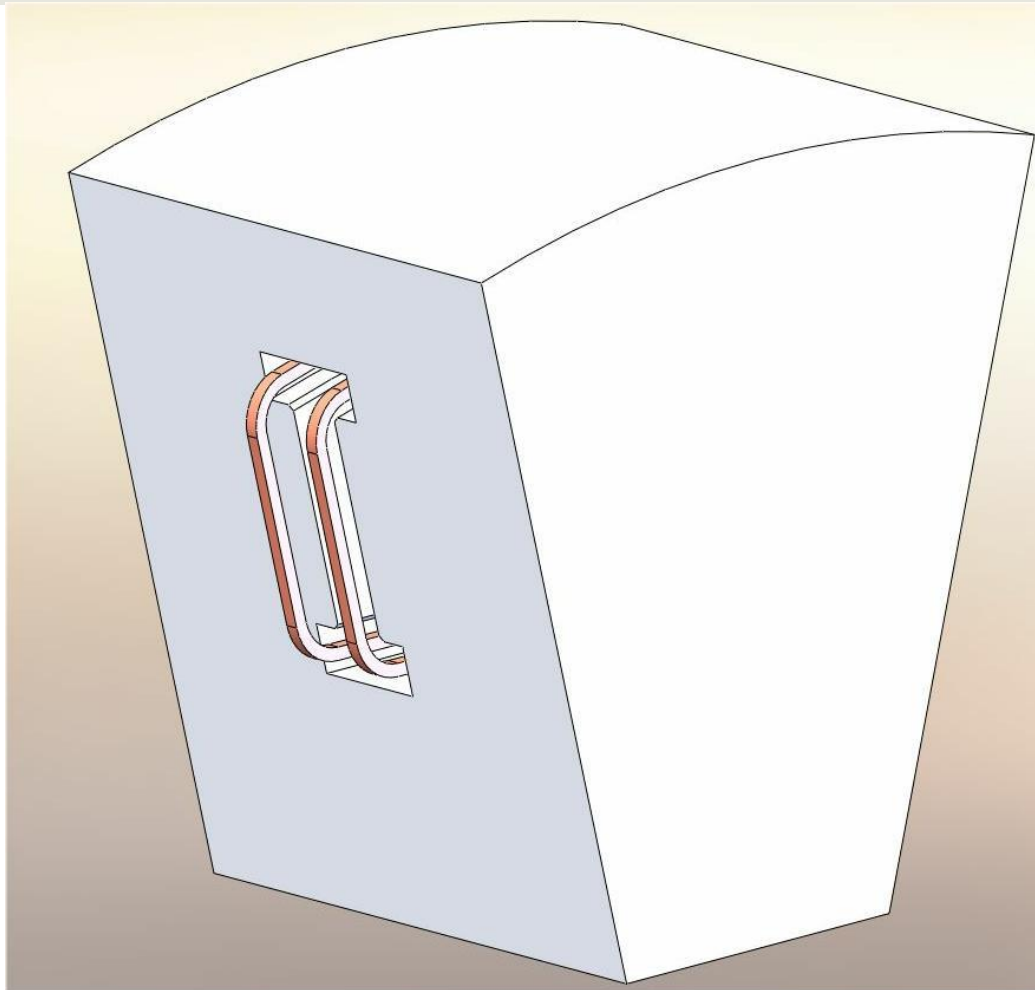

30 degree dipole(2)

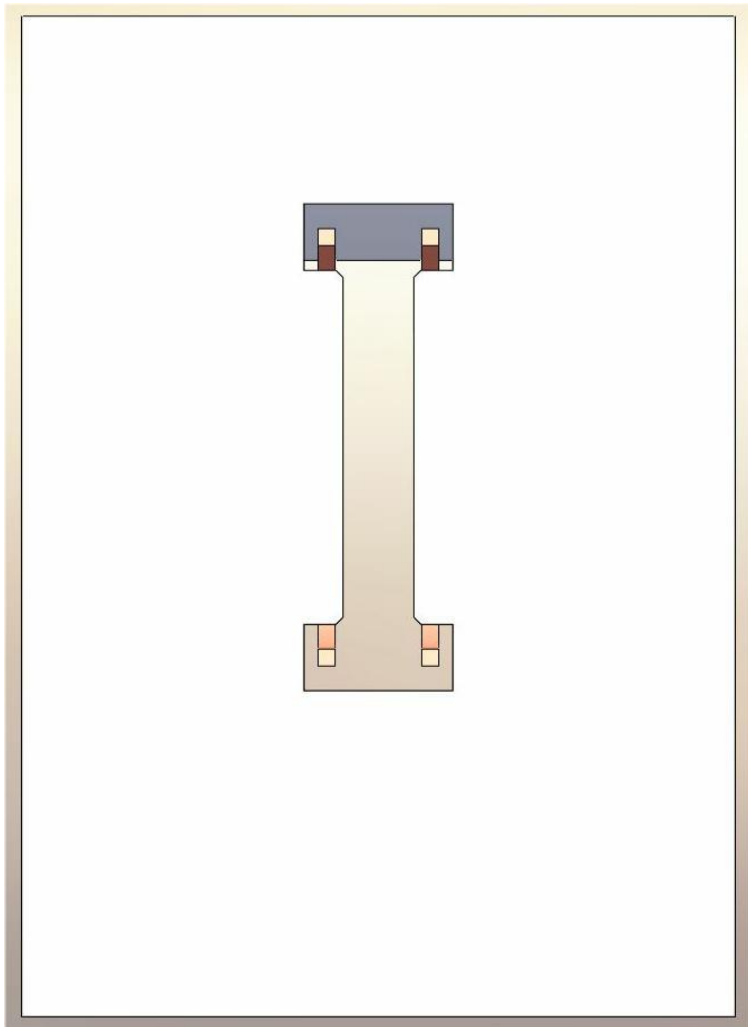

Conventional coil

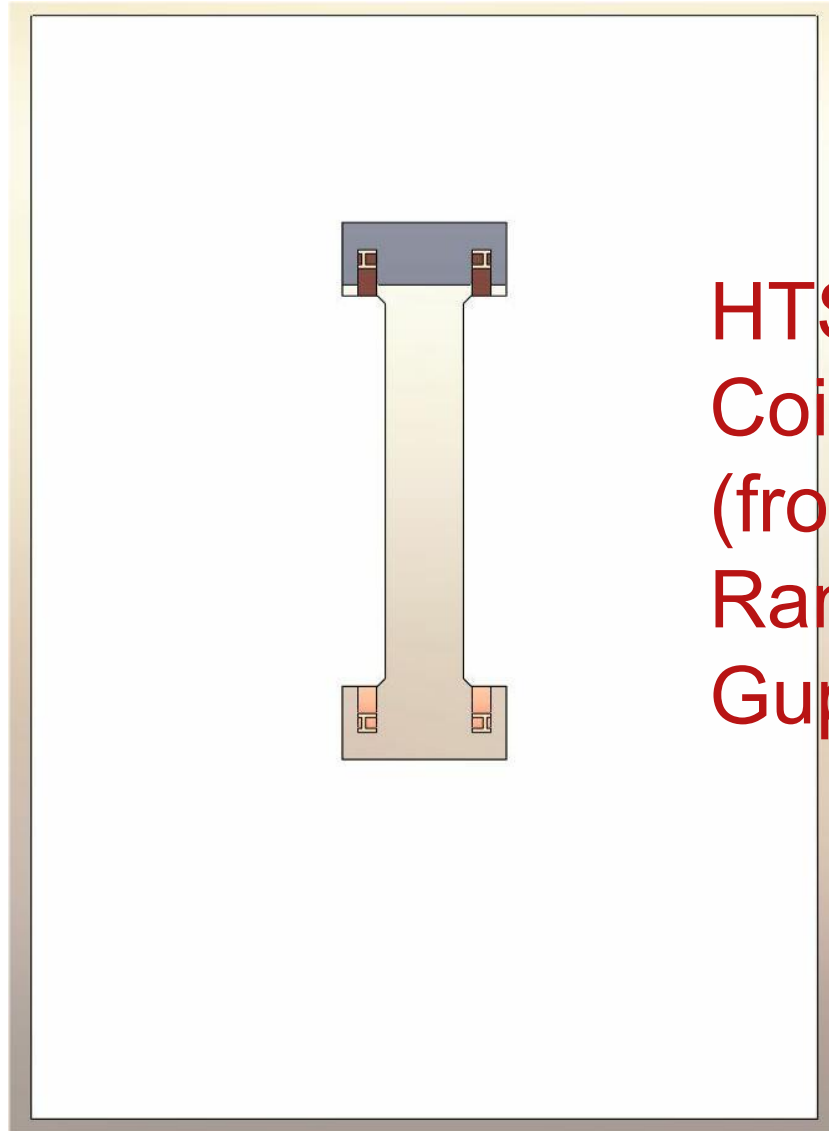

HTS
Coil
(from
Ramesh
Gupta)

Radiation resistant hex-oct

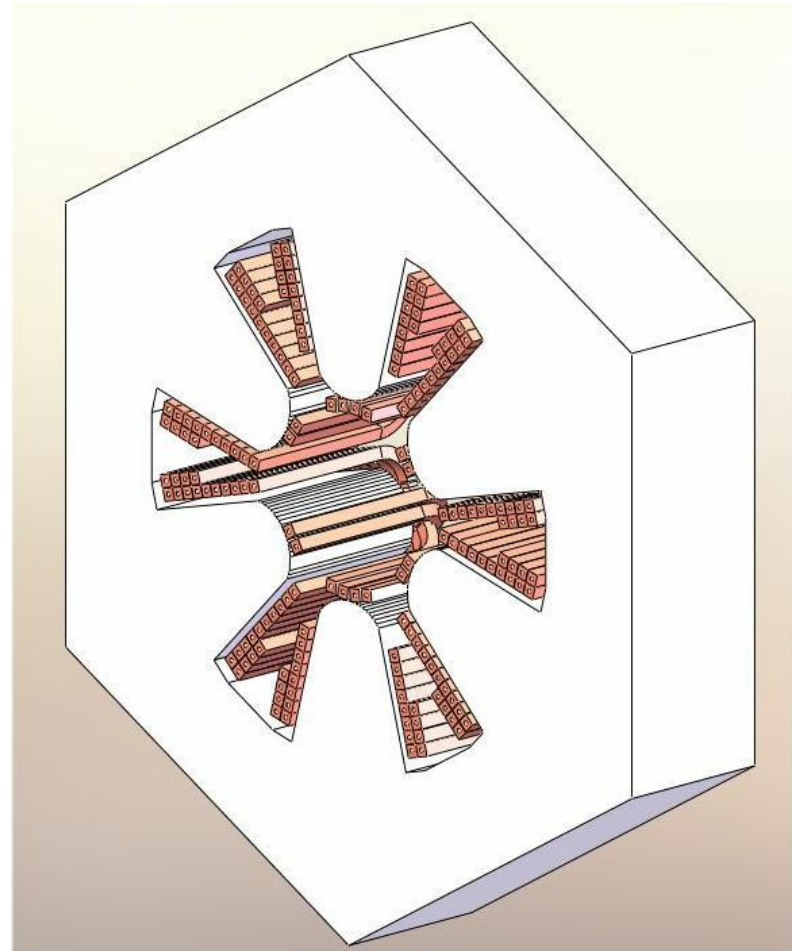
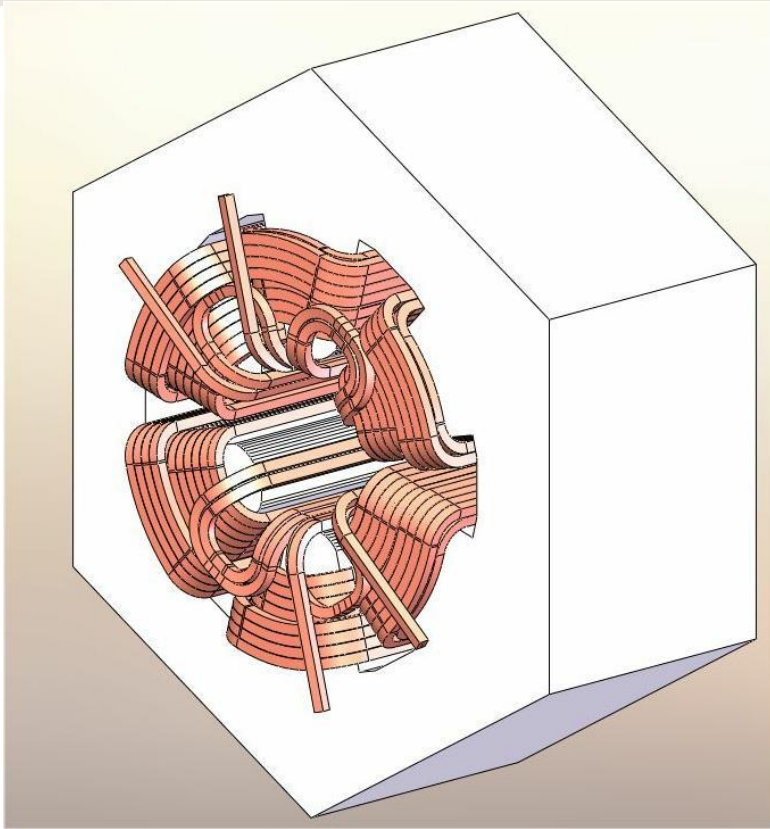

Uses 19 mm metal-oxide insulated hollow copper

Fragment Separator Mechanical Design

- Structural analysis performed
 - Realistic design for vacuum vessel and local shielding – basis for credible cost estimates
- Vacuum vessel design optimized
 - Improved pumping performance supports fast target and wedge changes
- Component alignment and mounting
 - Mount and alignment system design in hot-cell refined
 - Solutions for downstream fragment separator components developed
- Component design progressing
 - Details being developed
 - Remote-handling included

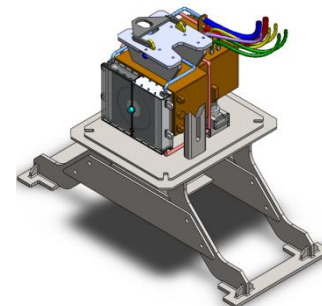
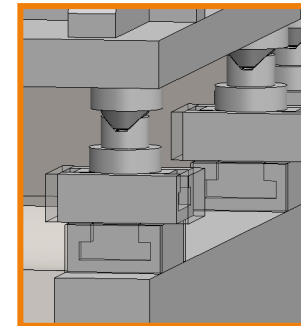
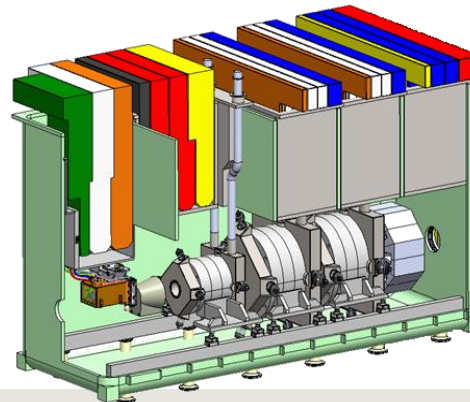
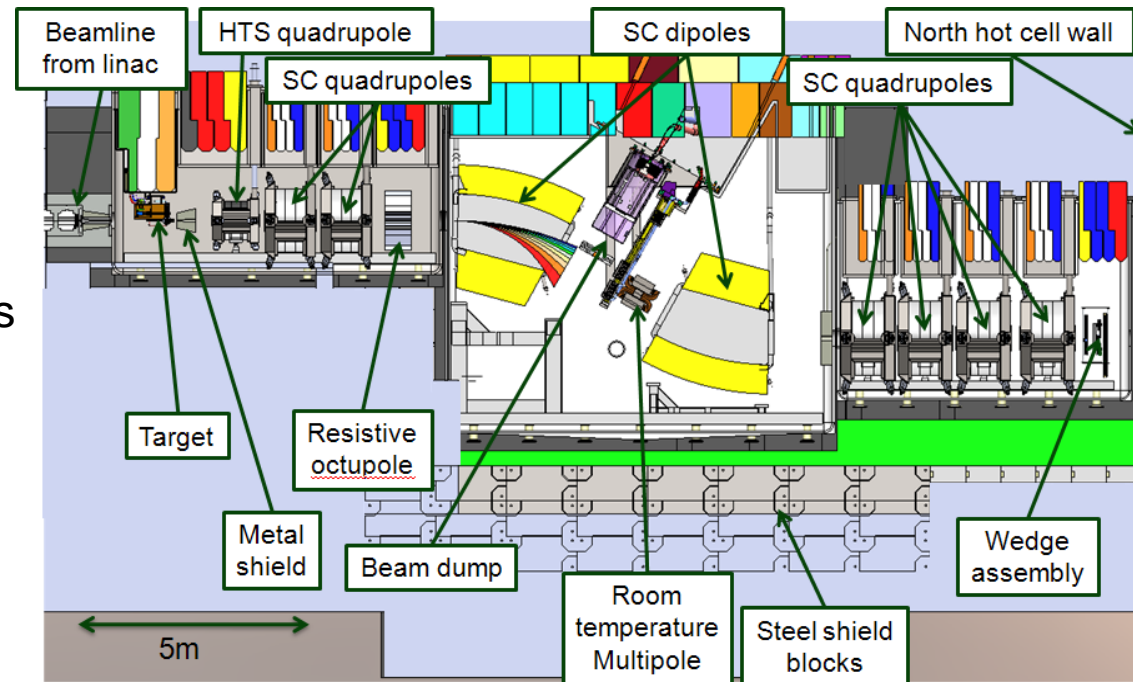

SC Magnet Remote Handling – Two Concepts Under Evaluation

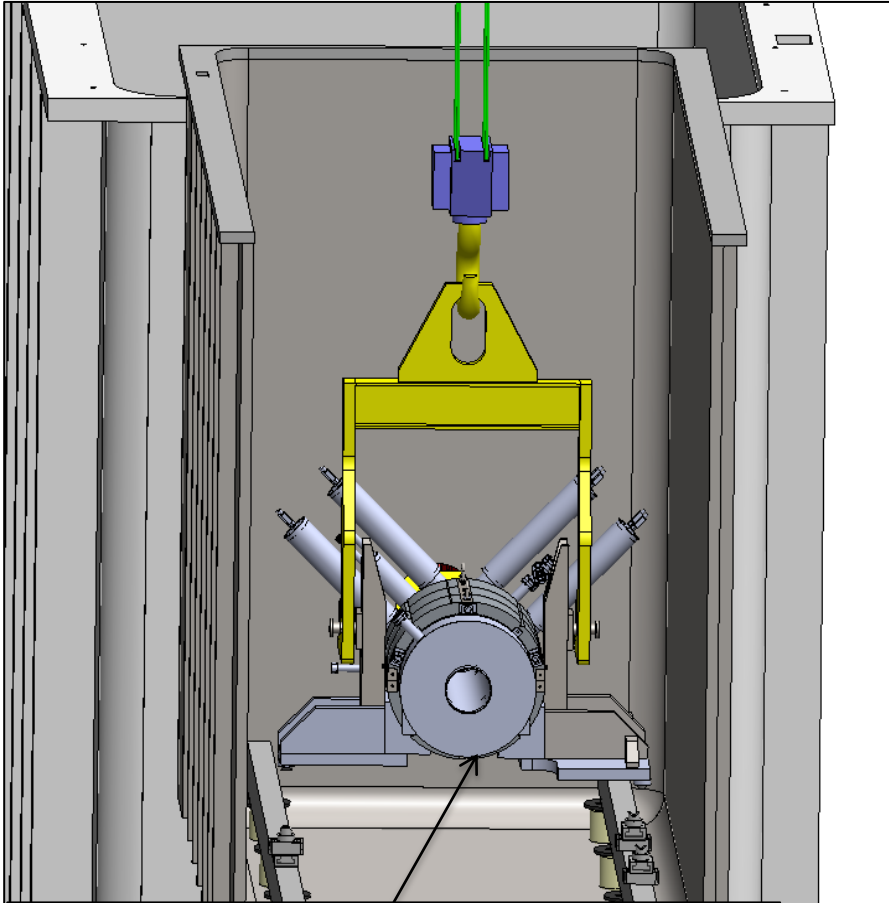

Remove complete magnet as a unit, all high precision assemblies completed at the window workstation but kinematic mounts are exposed to damage

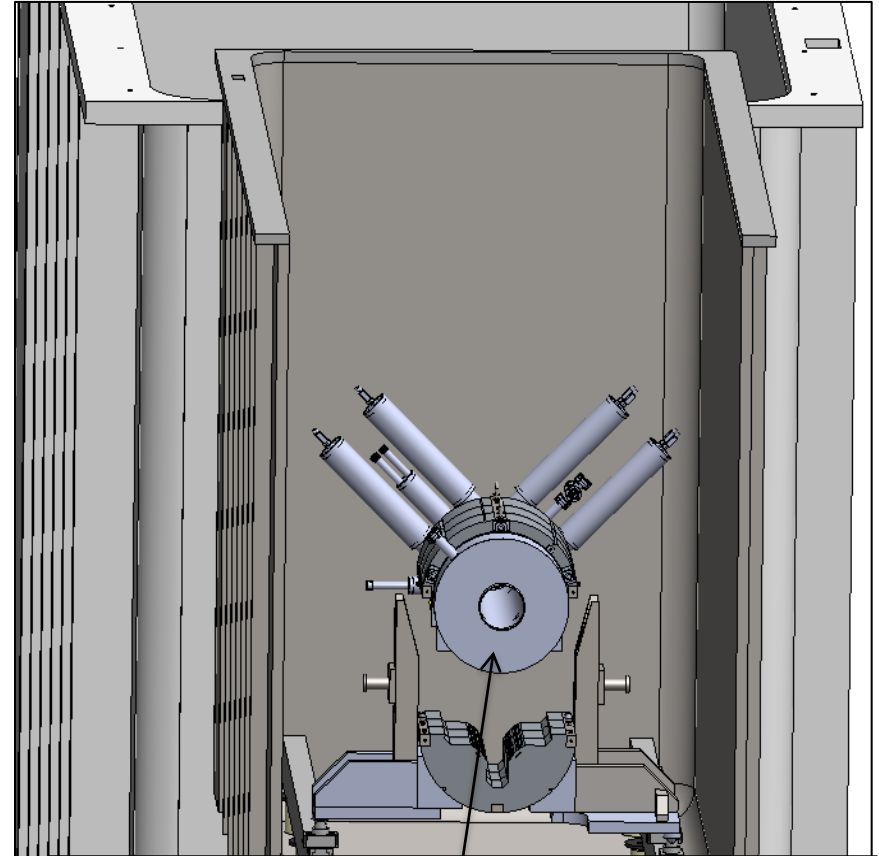

Remove upper yoke and coil package as a unit, leave lower yoke in vacuum vessel, close tolerance assembly process done with limited visibility, but kinematic mount is protected from damage

Mounts

Passive Precision Kinematic Mount Approach Adopted

- Magnets and beam line components require long term mount stability
- High precision adjustment is provided at initial installation
- Remotely serviceable shim system used to maintain magnet alignment after beam activation
- Individual tri-leg kinematic mounts are used by each beam line component to provide permanent automatic alignment during reinstallation after removal
- All kinematic mounts will have capability of adjustment after beam line activation through use of a reconfigured shim system
 - Realignment measurements are used to machine new shims with adjusted thicknesses and center positions
 - Magnet or other component to be realigned is removed from vacuum vessel with crane and placed at manipulator window workstation
 - Old shims are removed and new shims installed, then component is reinstalled onto alignment/support rails

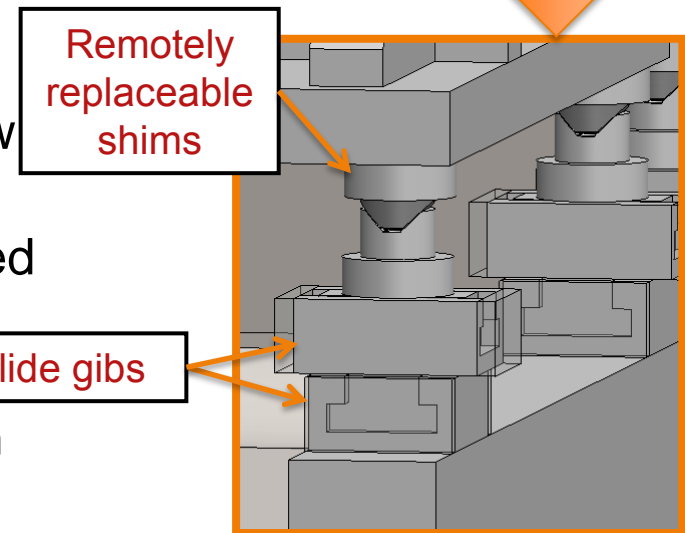
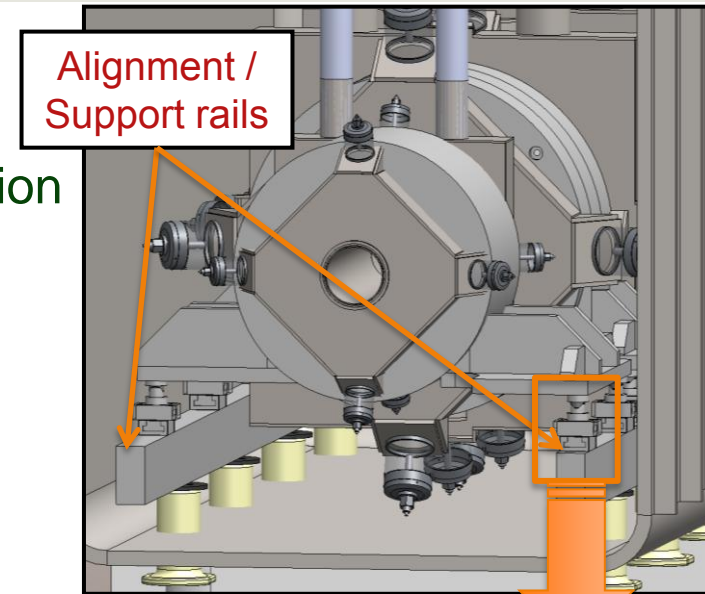

30 Degree Dipoles

- Yoke design will be compatible with different coil technologies, HTS or LTS
- In the process of evaluating BNL HTS coil design for baseline
- Detailed coil design is pending coil type decision, with no expected impact on availability of design at CD-2
 - SC coil design very similar to 50 degree dipoles
 - HTS coil design is less complex, i.e. no helium Dewar
- Yoke iron configuration provides some challenges to assembly process with the limited crane capacity and restricted access inside vacuum vessel
- Mounting scheme defined; independent of magnet type decision

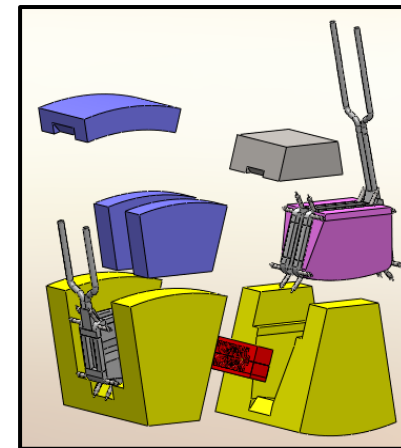
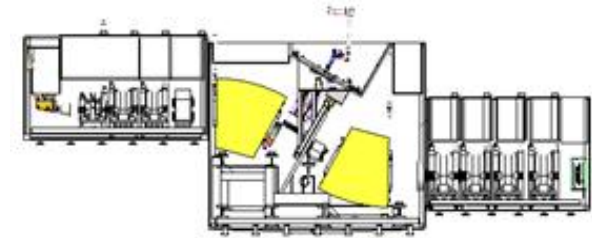

Dipole Remote Handling - Two Concepts Under Evaluation

CONCEPT 1
Consider mechanism to allow yoke halves to translate apart.

Estimated yoke mass about 75 tons, estimated coil package life is 3-5 years

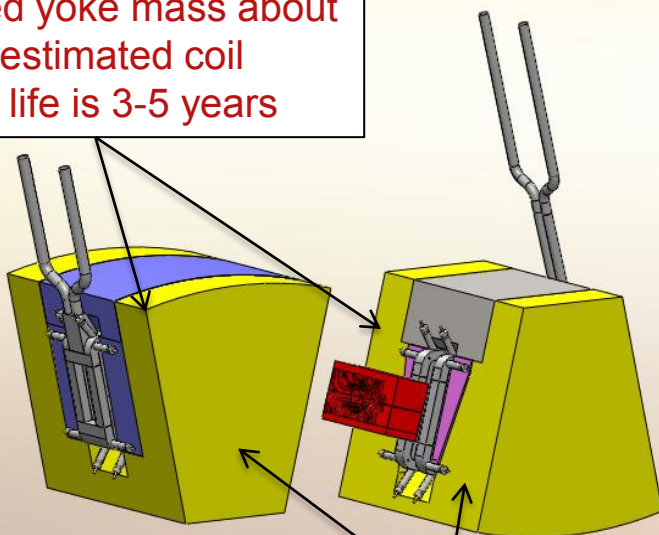

Both yokes likely requires active cooling estimated heat load 5 kW for dipole 1, 10 kW for dipole 2

CONCEPT 2
Consider tapered yoke hardware to insure intimate contact between parts to react magnetic loads.

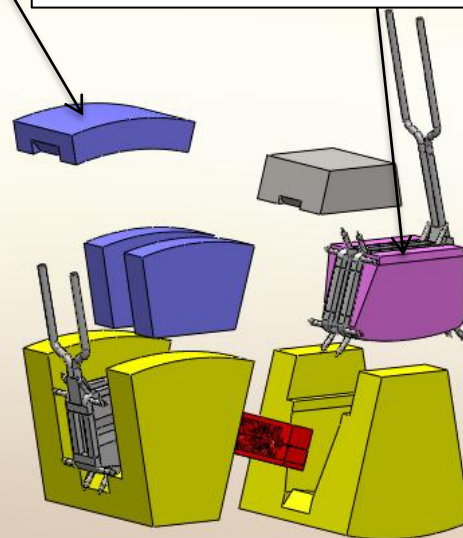

Assembled

Approaches to Disassemble

Design References for Fragment Separator Dipole Magnets

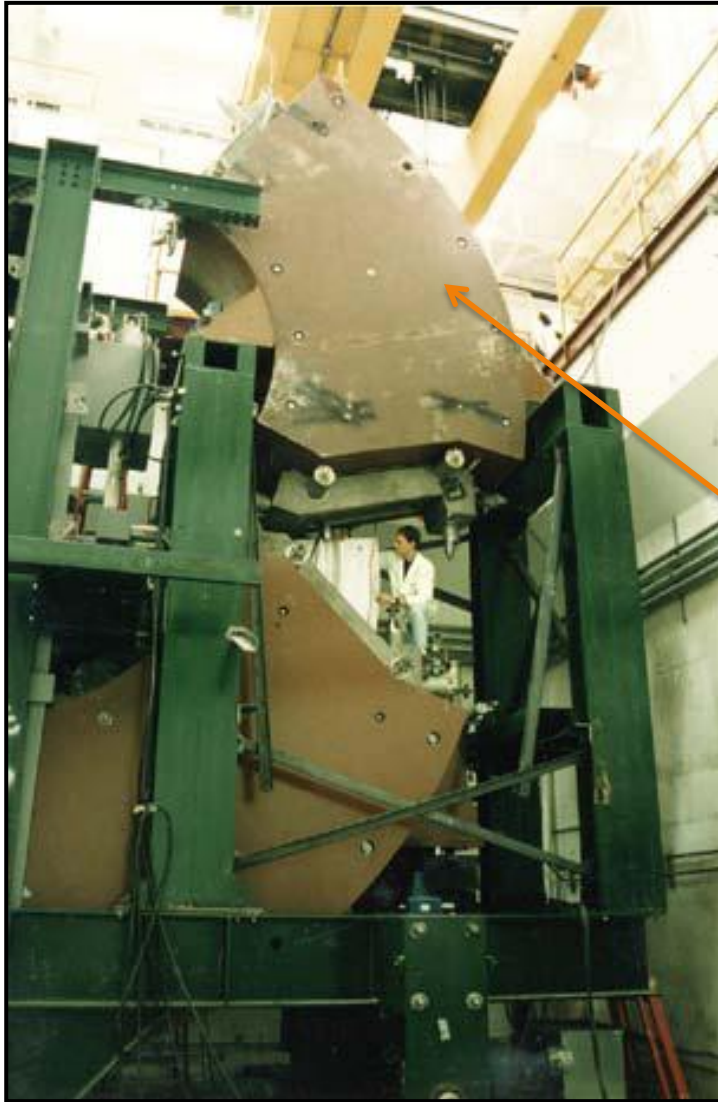

75 tons per dipole is similar in size to the FRIB 30 degree dipoles

NSCL – S800 Spectrograph

Overview Experimental Systems

Fragment Separator

- Outside of hot cell, radiation decreases, so we can use more conventional magnet construction techniques

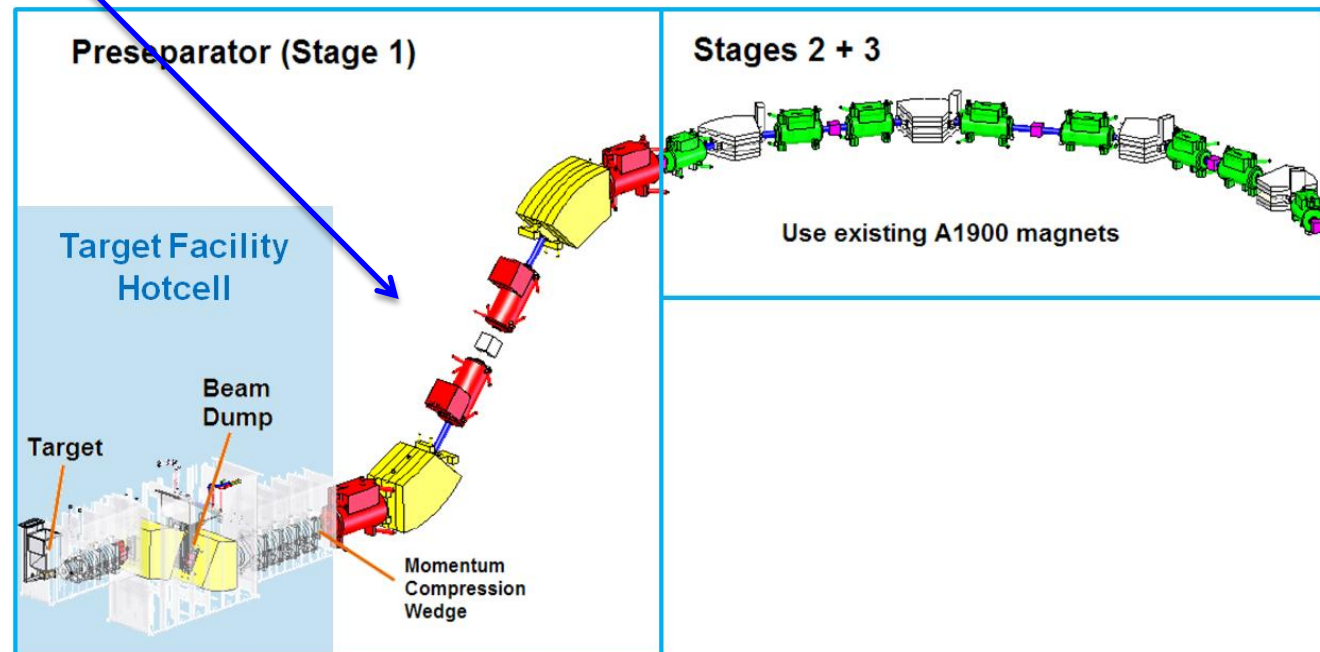

Horizontal cold iron triplet

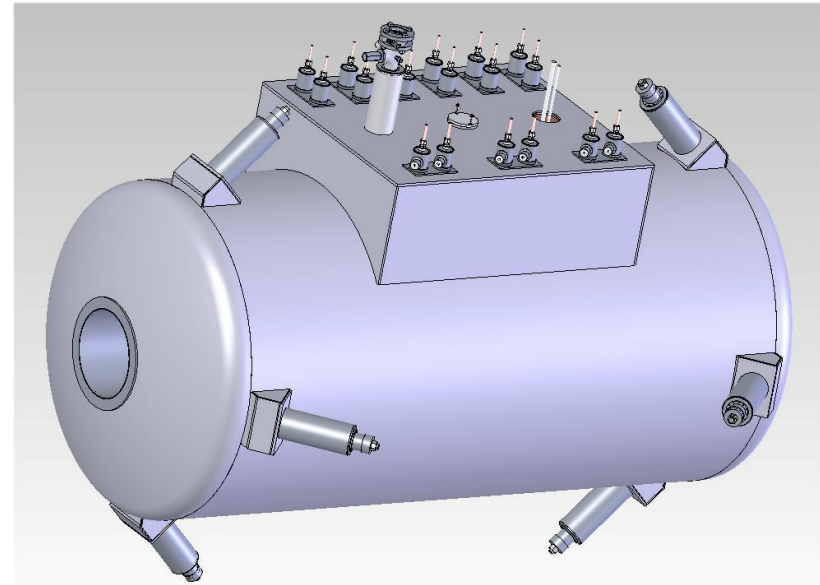
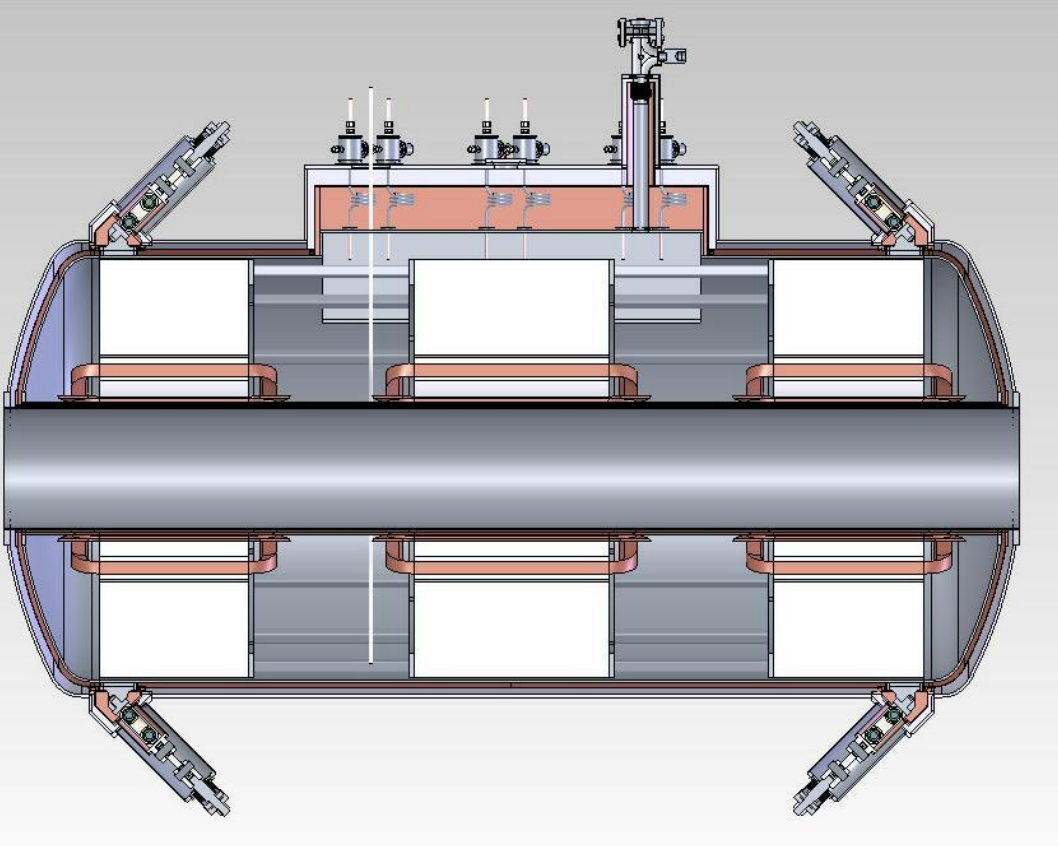

Cold iron triplet on 50° line

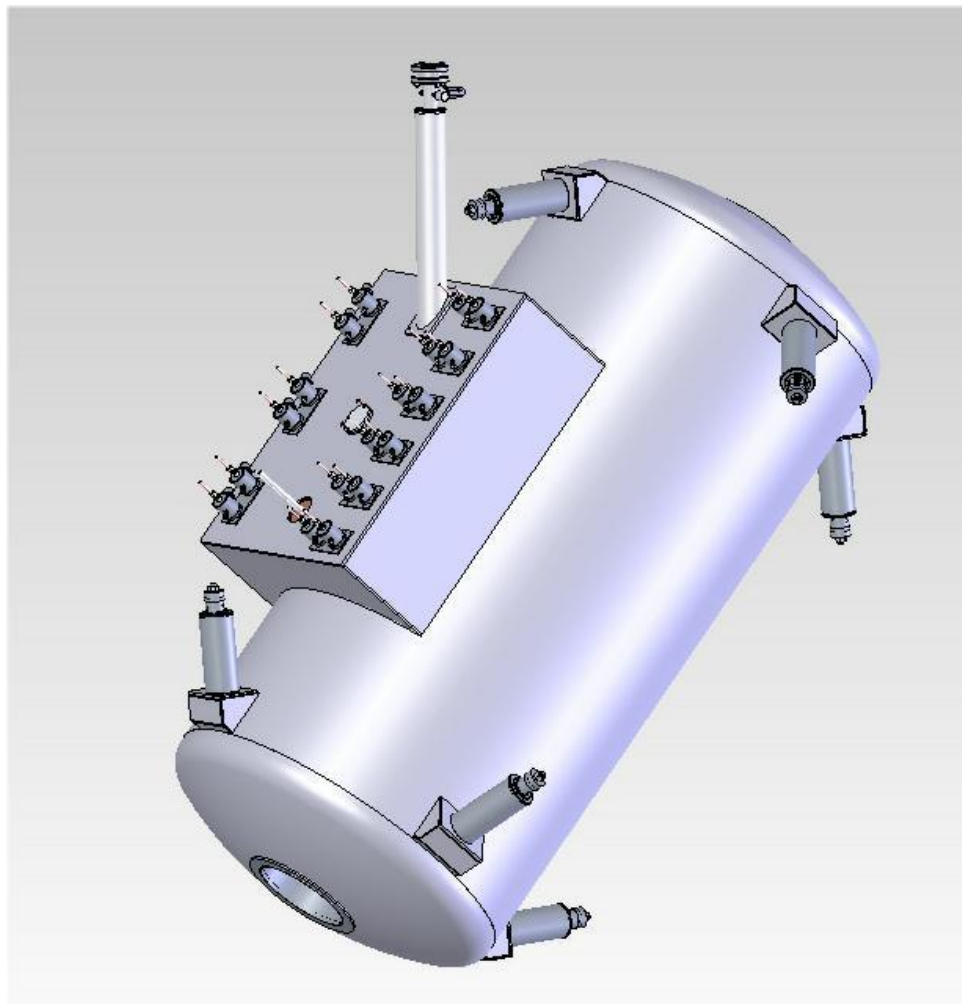
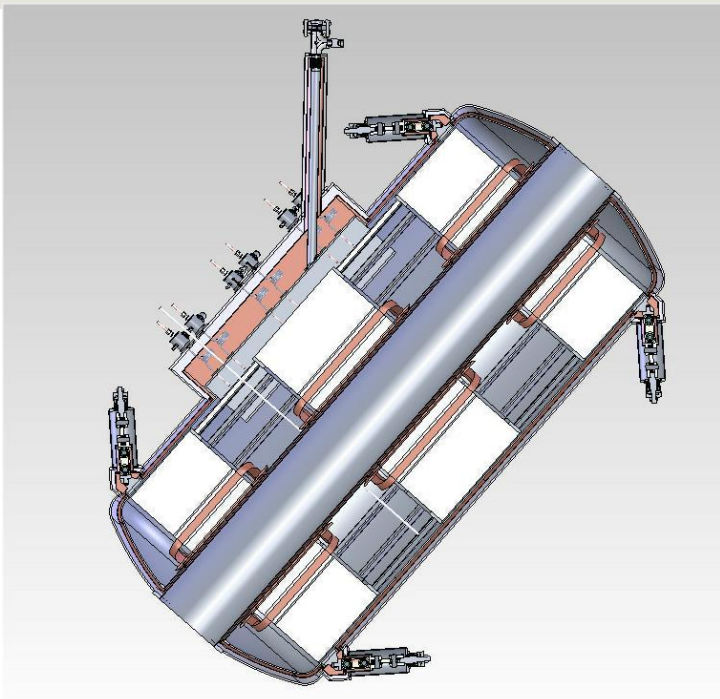

Cold-iron Quad Assembly [1]

Methods are Established – A1900

A1900 triplet cold assembly



Inserting the cold assembly into the helium vessel



50 degree dipoles

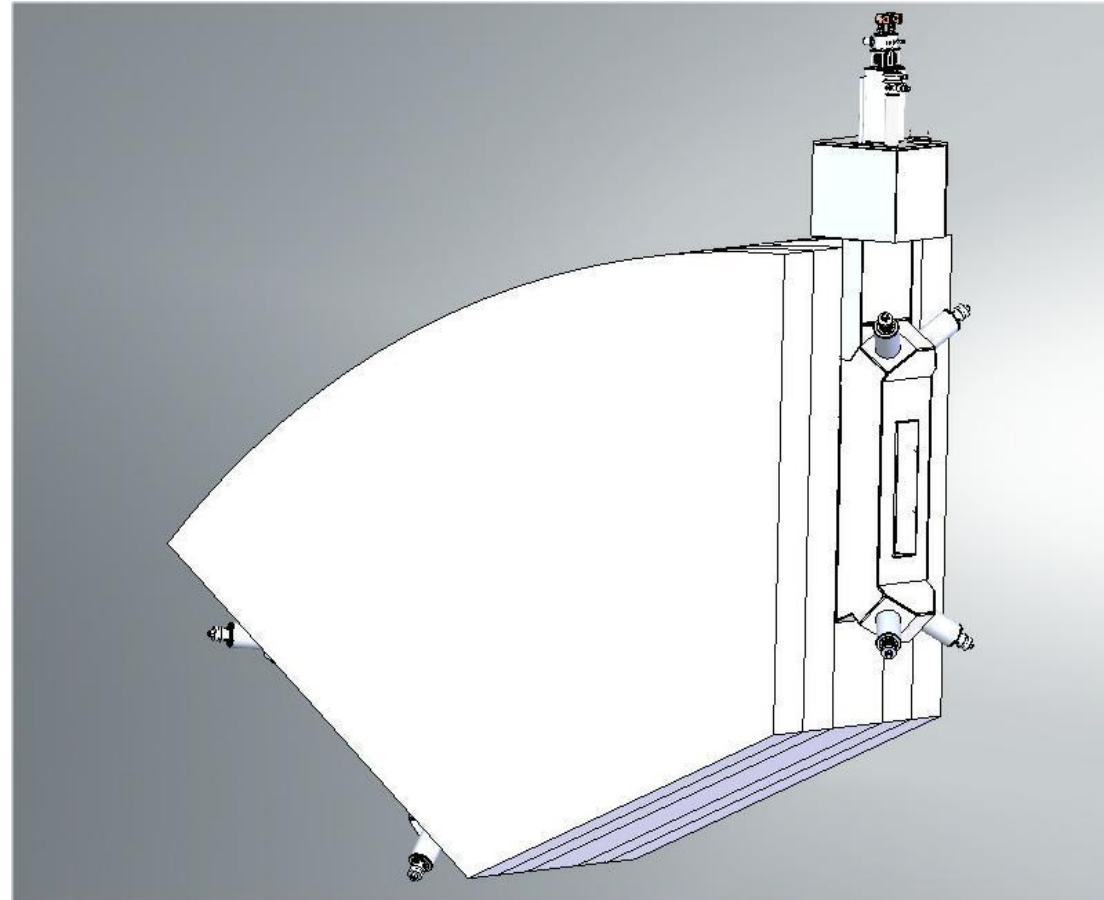
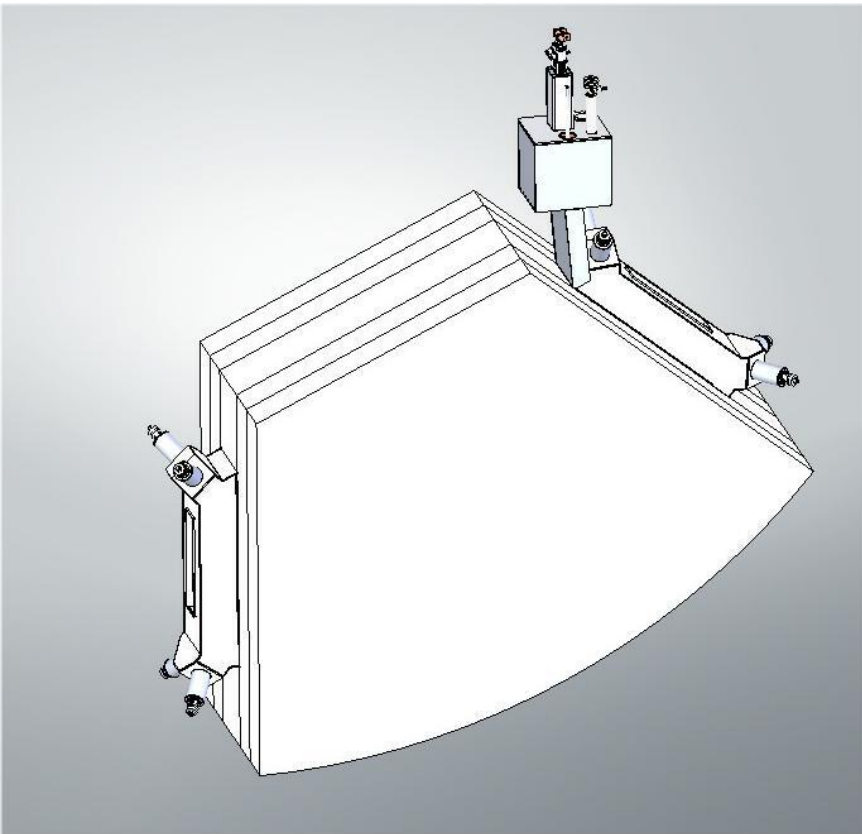

NSCL A1900 Type Magnets

Fabrication Technique Established

Complete coil

**Coils free standing –
not wound on bobbin**

Coil in bobbin

**Stainless steel tubes are
used to provide pre-load**

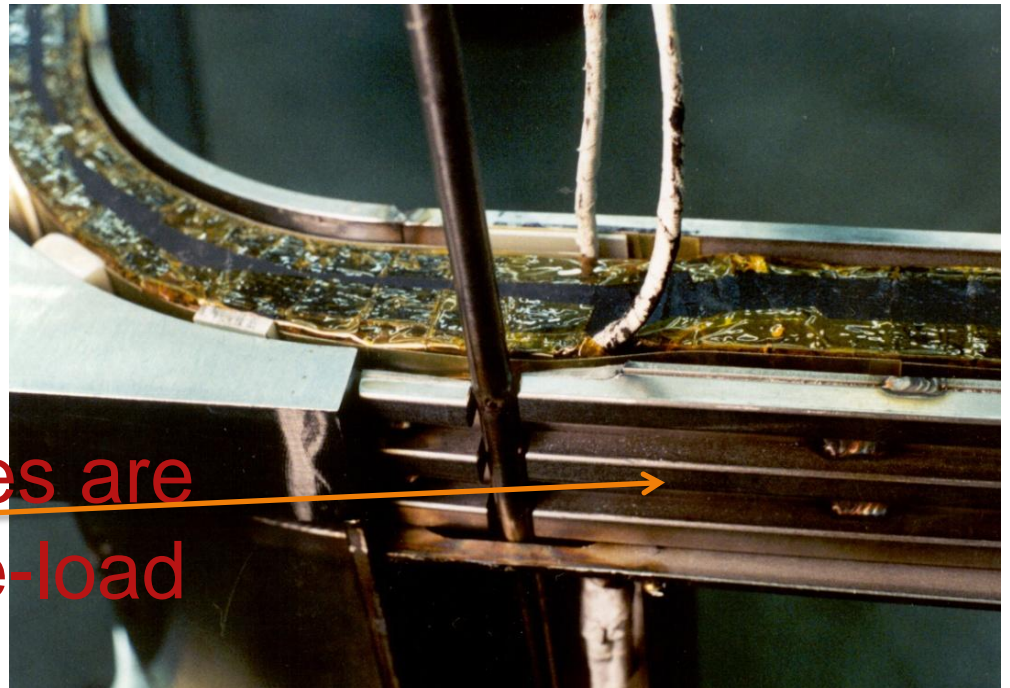

Target Facility Engineering/Design

CD-2/3A Path Supported by Radiation Transport Calculations

- Major radiation analyses are complete and support CD-2/3A
 - Radiation effects drive target facility design directly or indirectly (**Ronningen**)
- Bulk shielding determined and sufficient
 - Ground water and soil activation, air activation
 - Prompt radiation from beam interaction and from non-conventional utilities
- Inventory and activation analyses support system designs and hazards analysis
 - Inventory in cooling loops – potential releases
 - Activation of components
- Radiation heating and damage analyses to support equipment and utility design
 - Magnet heating, lifetime of critical components

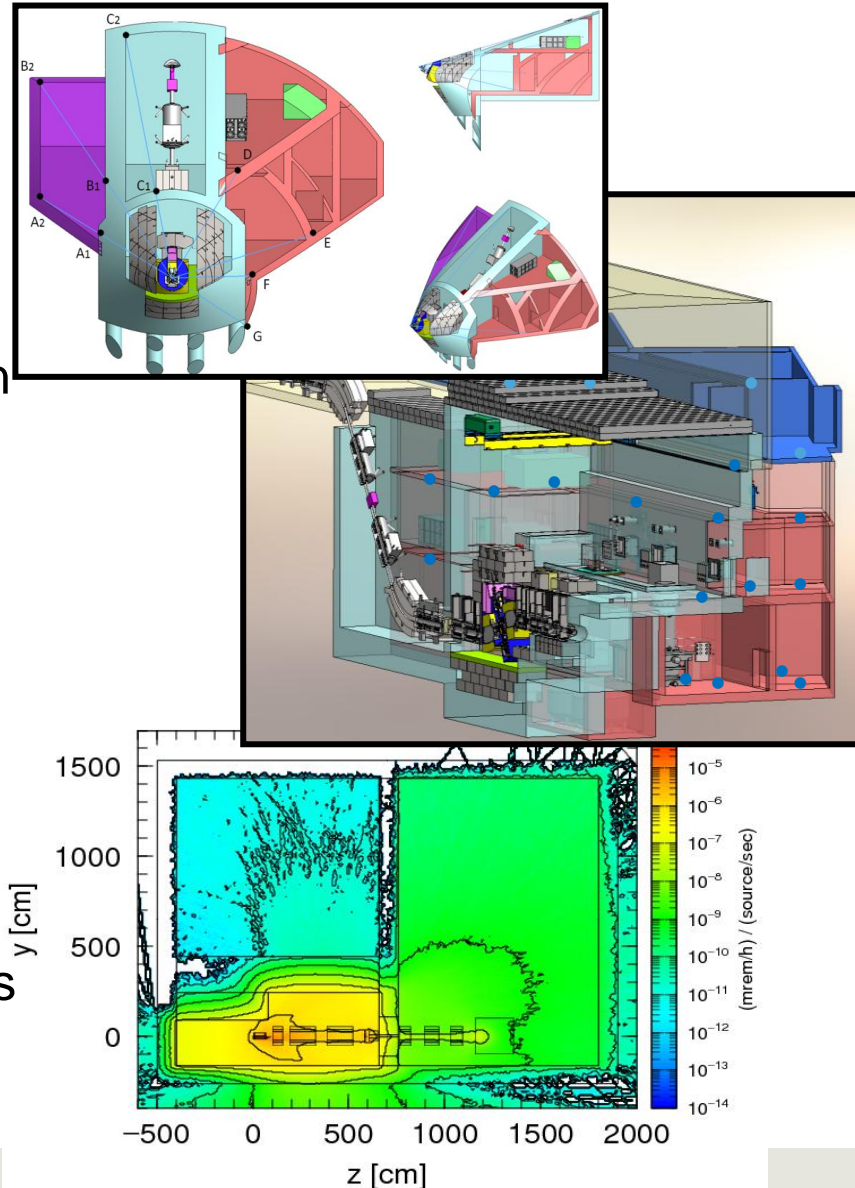

Target Facility Engineering/Design

On Track for CD-2/3A in Spring 2012

- Interfaces and boundaries defined
 - FRIB accelerator tunnel
 - Existing NSCL and MSU buildings and infrastructure
 - NSCL beam distribution system
 - Interruption of NSCL/CCF operation during civil construction
- Engineering/Design
 - Incorporates target/fragment separator system
 - Accommodates support systems (non-conventional utilities and remote handling equipment)
 - Fulfills maintenance and remote-handling requirements
 - Provides adequate shielding
 - Optimized room utilization, verified installation path

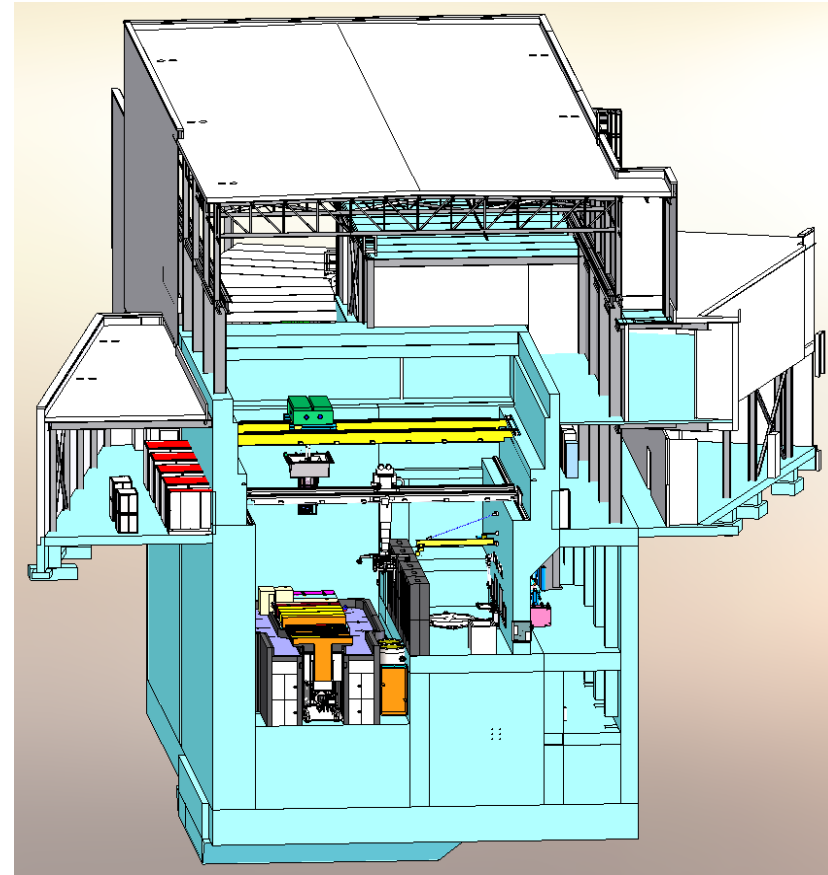

Target Facility Engineering/Design [2]

Supports CD-2/3A in Spring 2012

18-Borden

- Target hot cell, subterranean
 - » Production target
 - » Fragment preseparator
 - » Primary beam dump(s)
 - » Remote handling (RH) equipment

- Target facility building high bay
 - » 50 ton bridge crane
 - » Second and third stage of fragment separator
 - » Fragment separator power supplies

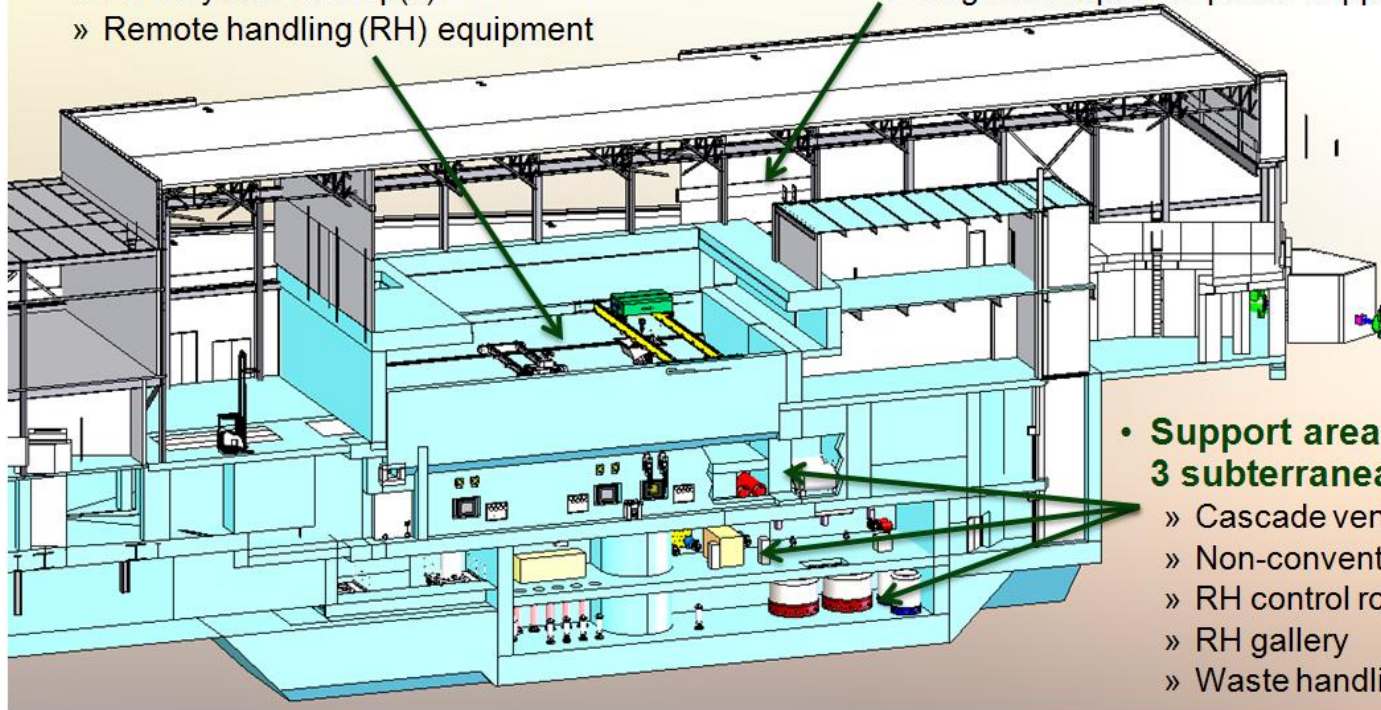

- Support areas, 3 subterranean levels
 - » Cascade ventilation
 - » Non-conventional utilities
 - » RH control room
 - » RH gallery
 - » Waste handling

- Optimized and engineering advanced
 - Layout of subterranean support areas to provide space for supporting equipment
 - Equipment location and ergonomics
 - Path for equipment installation

Conclusions

- Preliminary design that supports initial operations
- Integrated into complete target facility
- Transition to HTS coils in future upgrades