

# Muon Front End for a Neutrino Factory and Muon Collider



Chris Rogers,  
ASTeC,  
Rutherford Appleton Laboratory  
15th January 2013



# High Energy Muon Facilities

- Growing interest in large, high energy muon facilities
  - Neutrino Factory -> neutrino oscillations and
  - Muon Collider -> energy frontier or Higgs factory
- Sizeable R&D effort
  - Muon Accelerator Programme in US
    - Muon accelerator task force called by Fermilab director
  - International Design Study for a Neutrino Factory
- Supported by hardware prototyping
  - Muon Ionisation Cooling Experiment (MICE)
  - Electron Model with Many Applications (EMMA) prototype FFAG
  - Mercury Intense Target (MERIT)
- Such facilities have been made feasible by
  - Fast accelerating, high acceptance accelerators
  - Muon capture conceptual development



# Neutrino Factory Design

---





# Neutrino Oscillations

---

- Neutrinos created as superposition of 3 mass states
  - Different phase advance of mass states leads to oscillations between flavour states
  - Lepton flavour violation
  - Matter-antimatter asymmetry (CP violation)
- Governed by fundamental parameters
  - Square mass difference of mass states
  - 3 mixing angles
  - CP violating phase
- Seek to answer fundamental questions of the universe
  - Matter-antimatter asymmetry
- Seek to measure neutrinos precisely to answer these fundamental questions

# Neutrino Factory Concept



- Seek to manufacture neutrino beam from muon decay
  - Intense, high energy, pure
- Fire neutrinos several thousand km through the earth
  - Measure the change in the admixture of neutrinos
- Gives very sensitive device for analysis of neutrino oscillations
  - Better sensitivities than e.g. LBNE or Beta Beam
  - Beta beam + superbeam is competitive

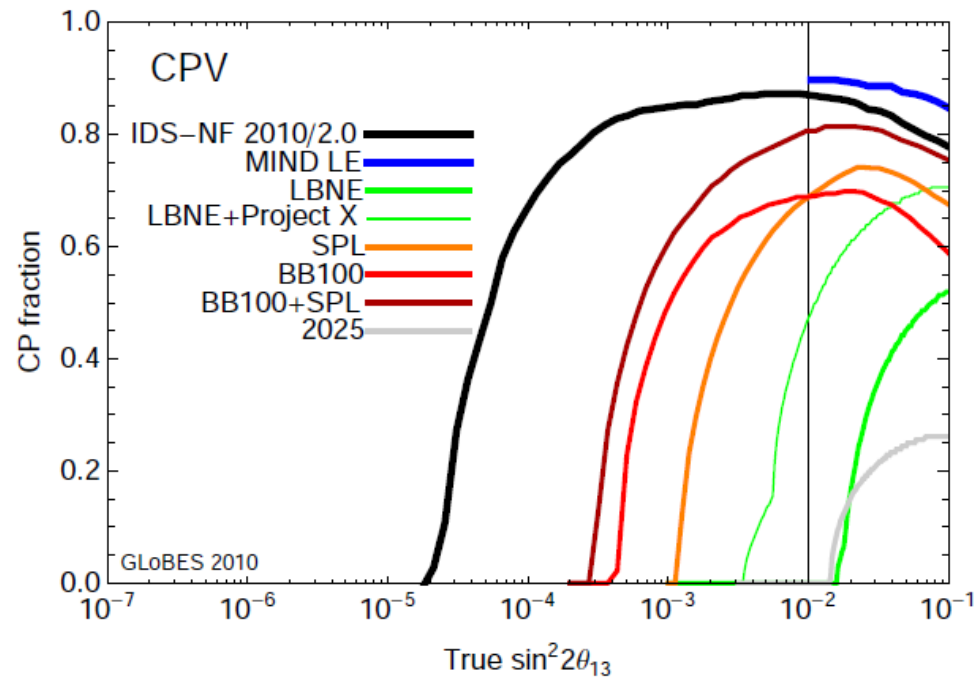

# Neutrino Factory Design



- Several iterations
  - 2(4) feasibility studies
  - FS1, FS2, FS2a, FS2b
  - International Scoping Study (2006)
  - International Design Study (IDS) ongoing

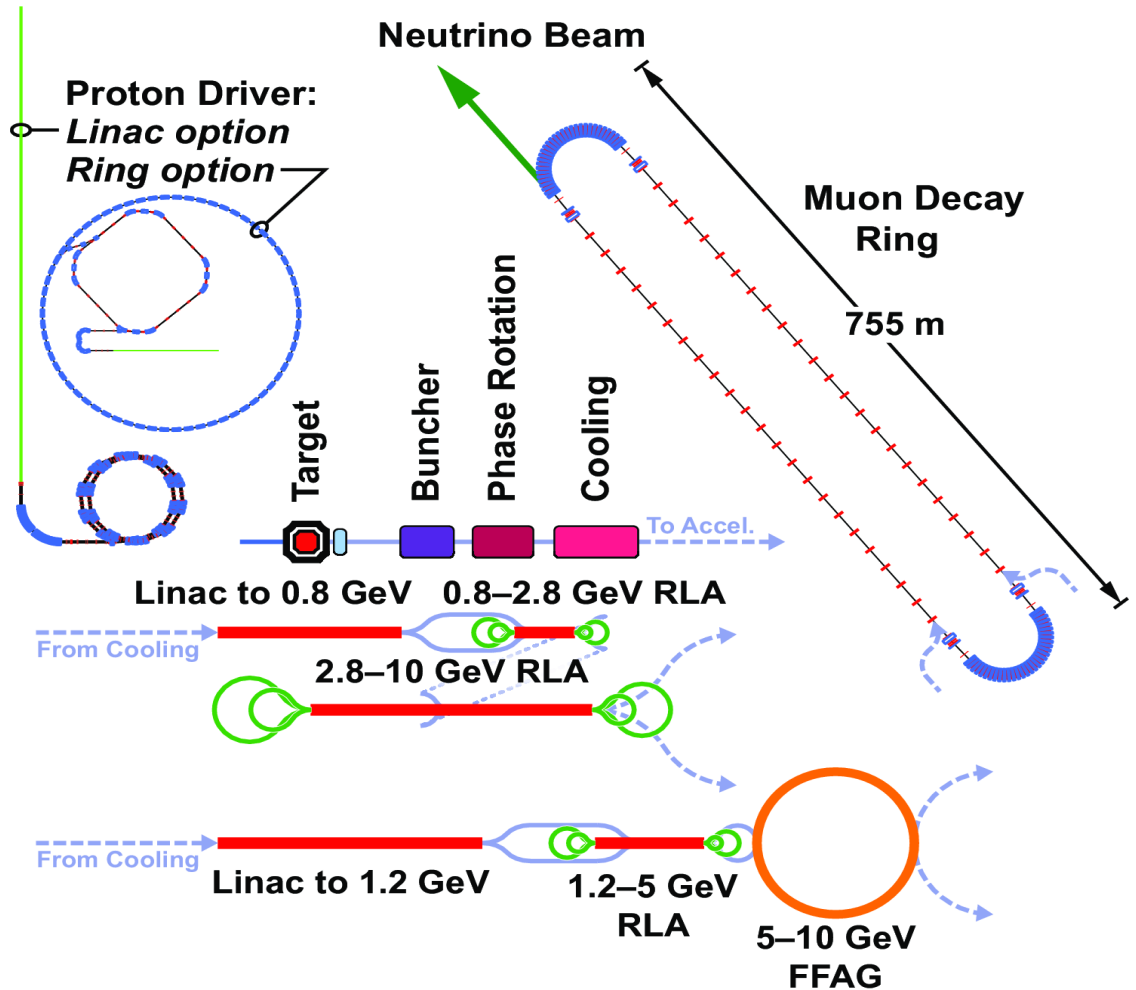

# Proton Driver

- Neutrino Factory requires a 4 MW proton source
  - 1 MW of SOTA proton sources
  - Demanding but feasible
- Aim for  $\sim 5\text{-}15$  GeV proton energy
  - Gives highest pion yield/beam power
  - Gives highest pion yield/shock on target
- Question: what is the challenge with 4 MW proton source?

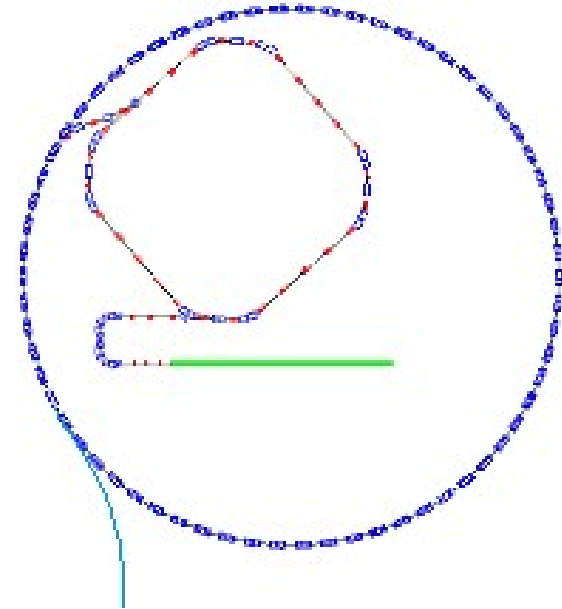

# Target

- Intense beam may quickly destroy solid target
  - Proposal to use liquid mercury jet
    - Pipe destroyed by cavitation
    - Jet will be contained by intense solenoid field
  - A PoP experiment recently finished successfully at CERN
    - MERcury Intense Target (MERIT)
- Solid target alternatives under study

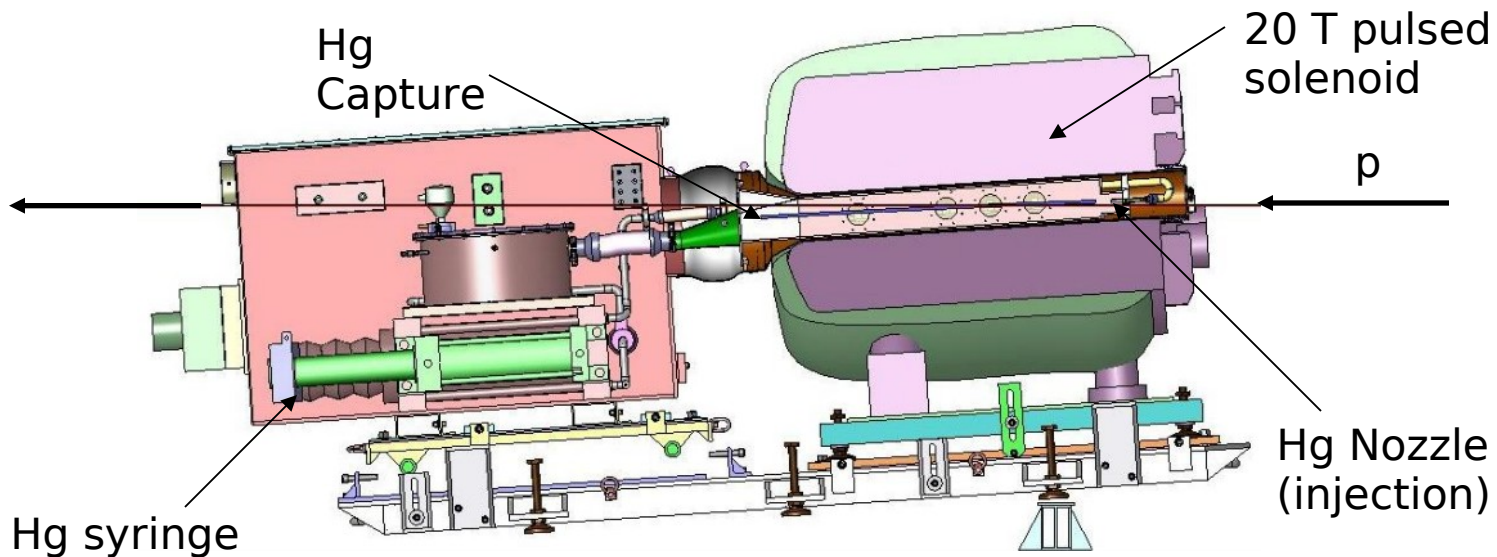



# Muon front end

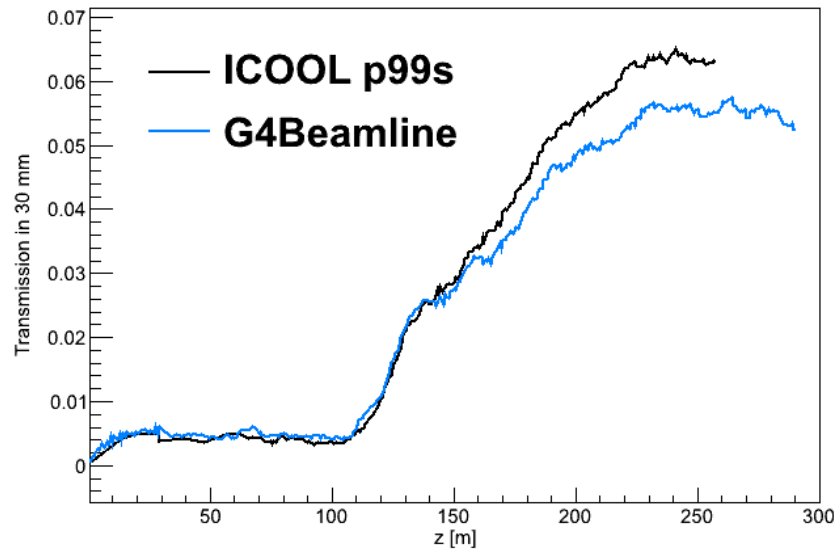

- Beam is very large after pion decay => difficult to control
- Capture longitudinally using fancy RF
- Capture transversely using ionisation cooling
- More in a few slides

# Recent news: Mice win Nobel Prize



## 'Designer mice' work wins Nobel prize

Maggie Fox  
Reuters

Tuesday, 9 October 2007

The gene-targeting technique that helped scientists create 'designer mice' has won its developers this year's Nobel Prize in Medicine or Physiology.

The technique is used by scores of labs across the world and has helped pin down the function of 10,000 different genes.

Three researchers were awarded the prize for their work, which was done separately but when taken together made possible the 'knock-out' mice that are now key to basic medical research.

Professor Martin Evans of the UK's [Cardiff University](#) laid the groundwork by discovering and isolating embryonic stem cells in mice, the master cells that make up a days-old embryo and which give rise to an entire living animal.

Evans figured out how to genetically tinker with the cells and implant these altered embryos into foster mothers, which gave birth to mice with the desired genetic changes.

Professor Mario Capecchi of the US [Howard Hughes Medical Institute](#) and the [University of Utah](#) and Professor Oliver Smithies of the [University of North Carolina](#) independently developed precise ways to disable, or knock out, a single chosen gene.



The technique has helped to pin down the function of 10,000 different genes and is used by labs around the world (*Image: iStockphoto*)

# Acceleration

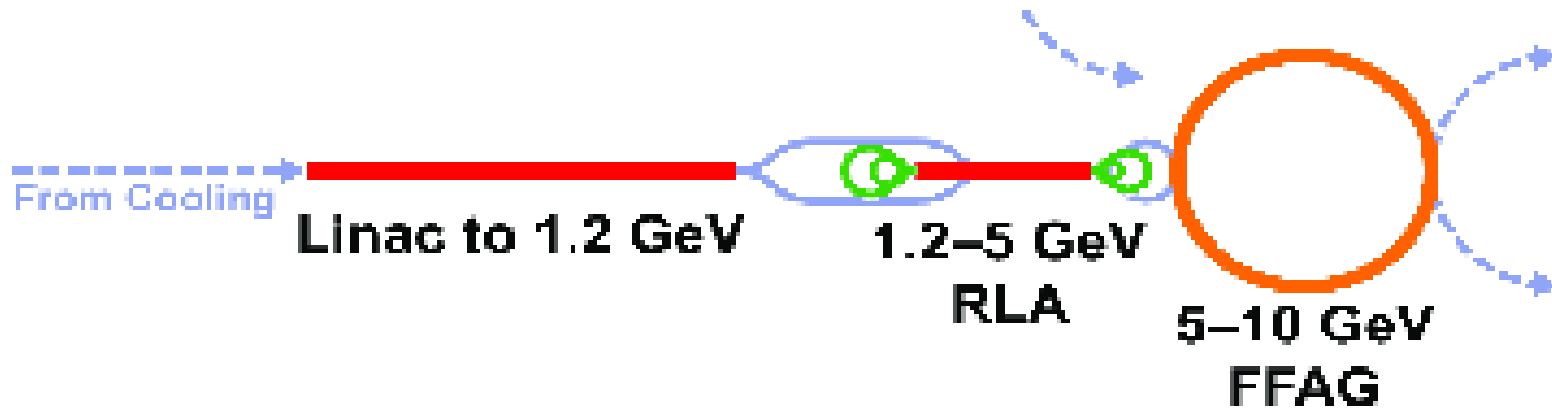

- Two technologies in acceleration chain
  - Recirculating Linear Accelerator (RLAs) in dogbone geometry
  - Fixed Field Alternating Gradient machines (FFAGs)
- Enables
  - Acceleration on time scale of muon lifetime
  - Acceleration with large apertures
- Acceleration to 10 GeV

# Storage Ring

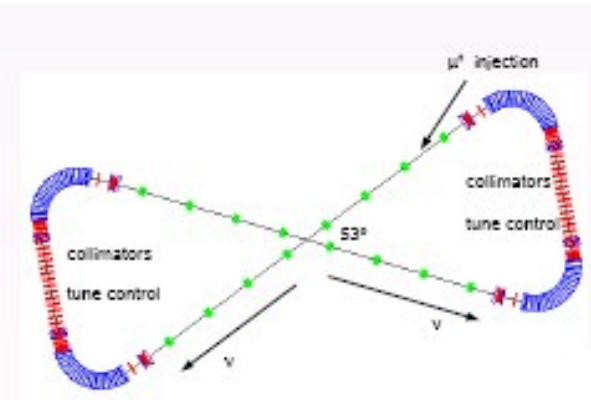
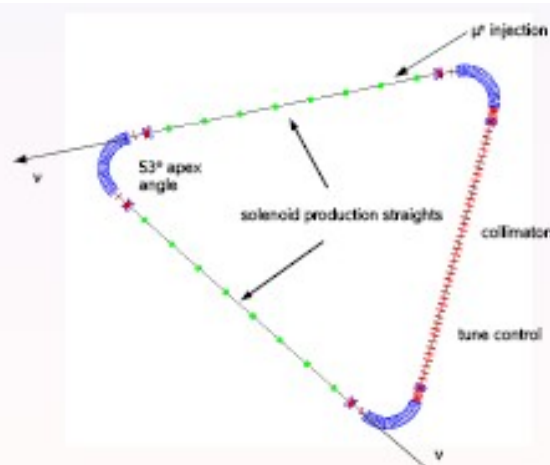
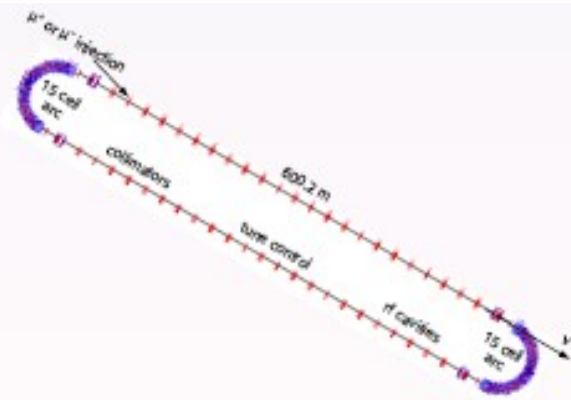

- Goal: maximize muon decays in straight sections
  - Racetrack, Triangle/Bowtie geometries have been examined
- Racetrack is currently favoured (most flexibility)
  - use long straight sections  $\sim 400$  m
  - vertical depth of ring can be issue for long baselines
- Use  $\mu^+$  and  $\mu^-$ 
  - Gives access to measurement of unitarity in neutrino mixing matrix



# Muon Collider Design

---





# Muon Collider Concept



- Aim is to reach energy frontier lepton collisions using muons
  - Challenge to get sufficiently high luminosity for interesting physics
    - Need lots of cooling
- “High emittance case”
  - Target -> Buncher -> Straight Cooler -> Guggenheim Cooler -> Debunch -> Guggenheim Cooler -> Acceleration
  - Possible to construct a Higgs Factory
  - Possible to construct a 4 TeV lepton collider (or more)
- Can be constructed in stages
  - Neutrino Factory -> Higgs Factory -> 4 TeV Muon Collider
- Cooling technology is the challenge

# Muon Collider Concept

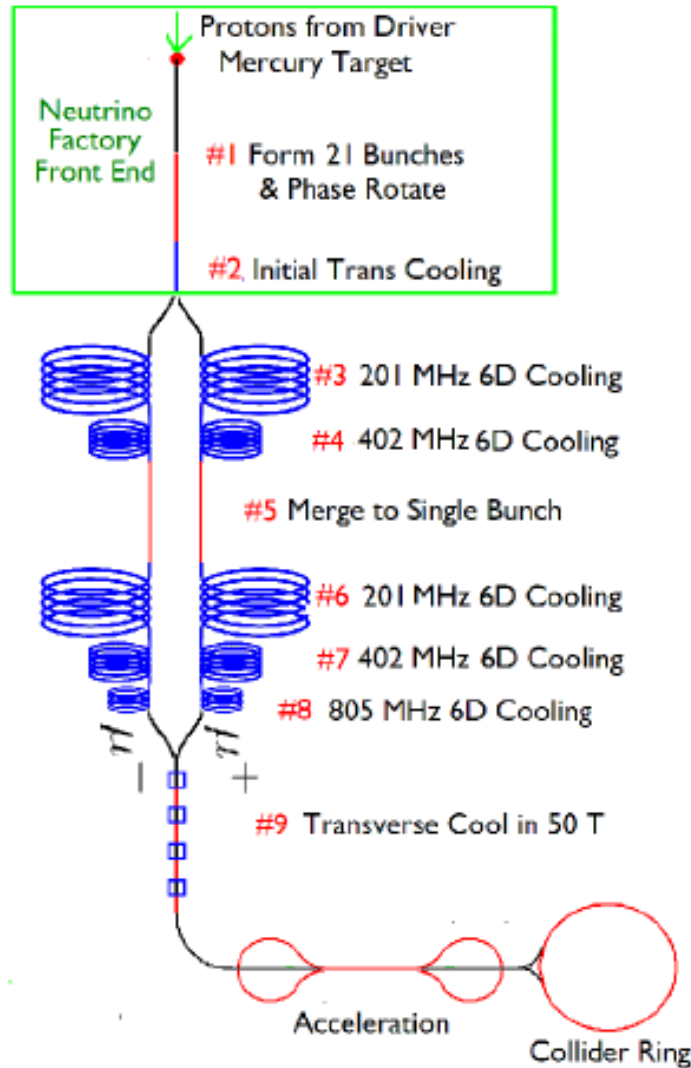

# Muon Collider emittance map



## New 6D cooling with less exchange

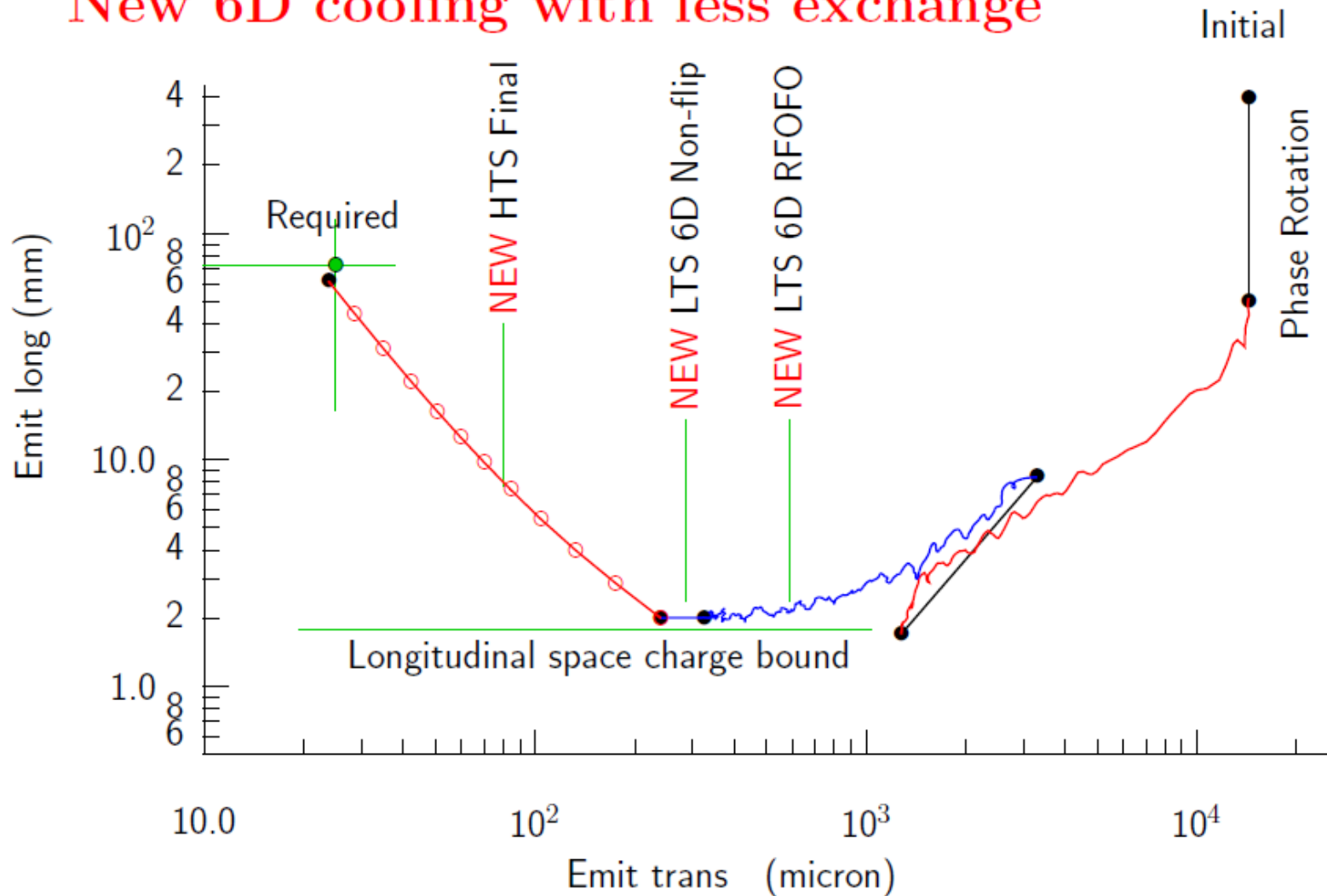



# Roadmap for HEMC (@ Fermilab)

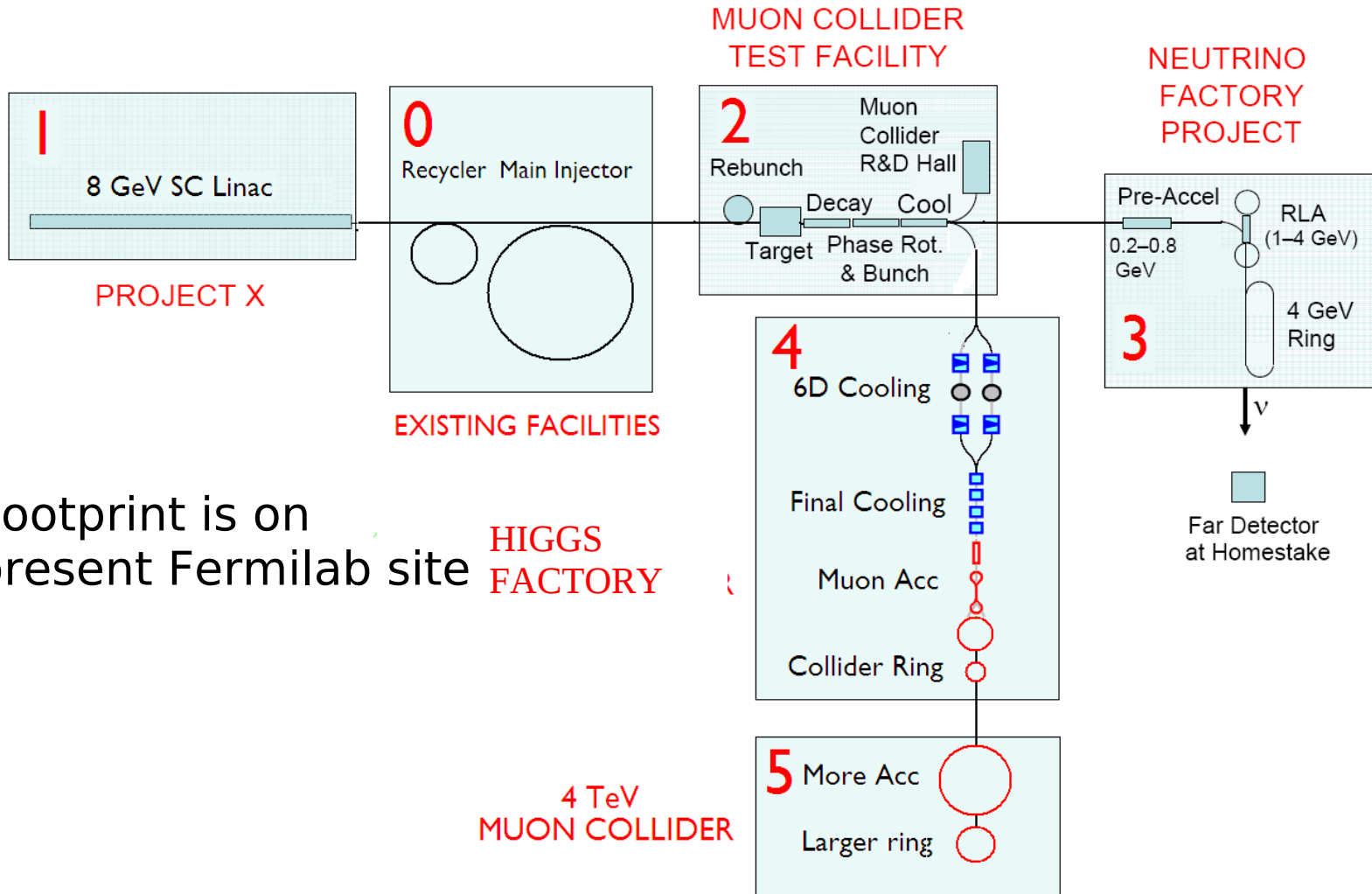

- Footprint is on present Fermilab site



# Muon Front End

---



# Baseline Front End



- Adiabatic B-field taper from Hg target to longitudinal drift
  - Drift in  $\sim 1.5$  T,  $\sim 100$  m solenoid
- Adiabatically bring on RF voltage to bunch beam
- Phase rotation using variable frequencies
  - High energy front sees -ve E-field
  - Low energy tail sees +ve E-field
  - End up with smaller energy spread
- Ionisation Cooling
  - Try to reduce transverse beam size
  - Prototyped by MICE
  - Results in a beam suitable for acceleration

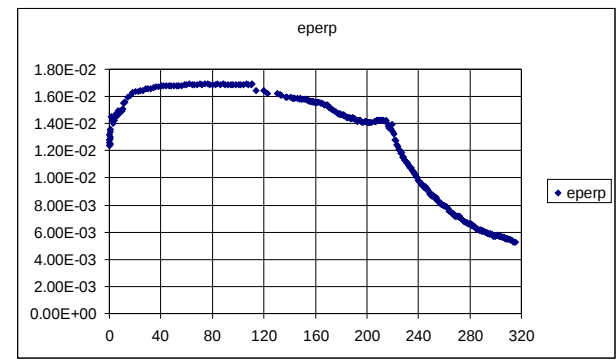
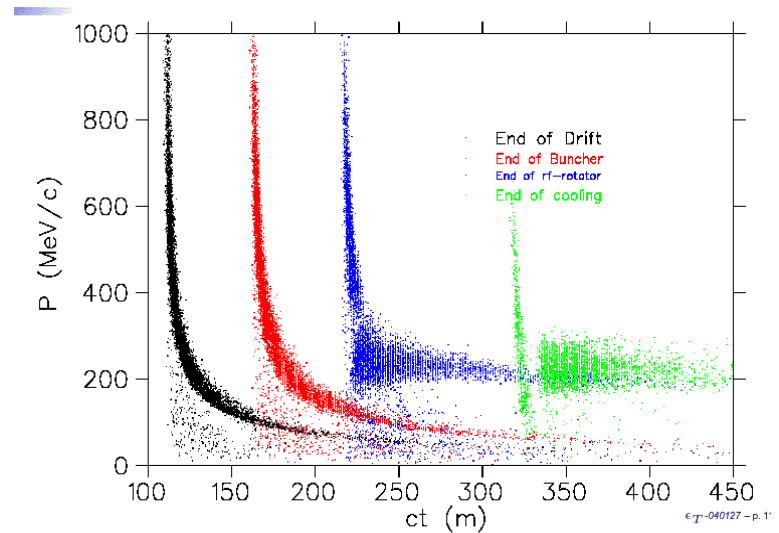
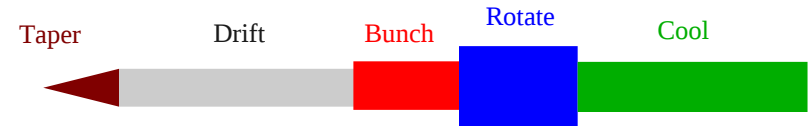

# Secondary Particle Contamination



Significant problem with secondary particles in the front end

- Potentially activate the entire front end
  - Potentially activate later acceleration system
    - Kickers, septa, etc
  - Additional heat load on e.g. superconductors
  - Not acceptable
- Plan is to manage using chicane and proton absorber
- Chicane removes high momentum particles ( $p > 500$  MeV/c)
  - Absorber removes low energy particles ( $p < 500$  MeV/c)
  - Leaves low energy electrons and muons

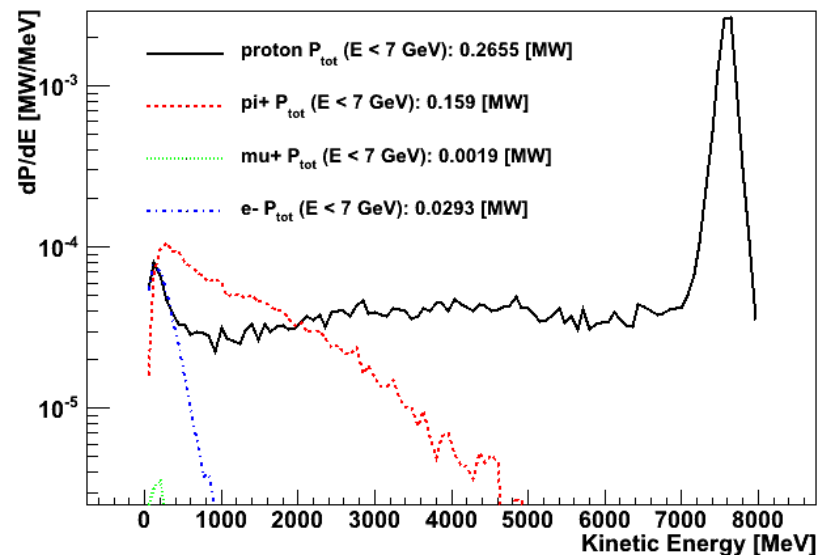
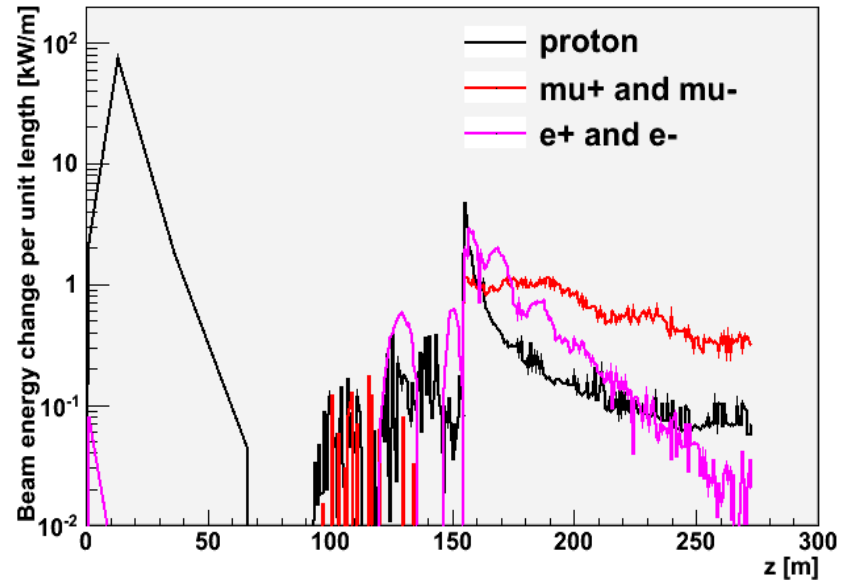

# Particle selection scheme



- Bent solenoid chicane induces vertical dispersion in beam
  - Single chicane will contain both signs
    - Opposite signs have dispersion in opposite sense
    - Dispersion is **vertical**
  - Little disruption to the actual beam
  - High momentum particles scrape
- Subsequent proton absorber to remove low momentum protons
  - Non-relativistic protons don't have much energy, even for relatively large momenta
- Not yet in “baseline” but aim to get it in in next few weeks

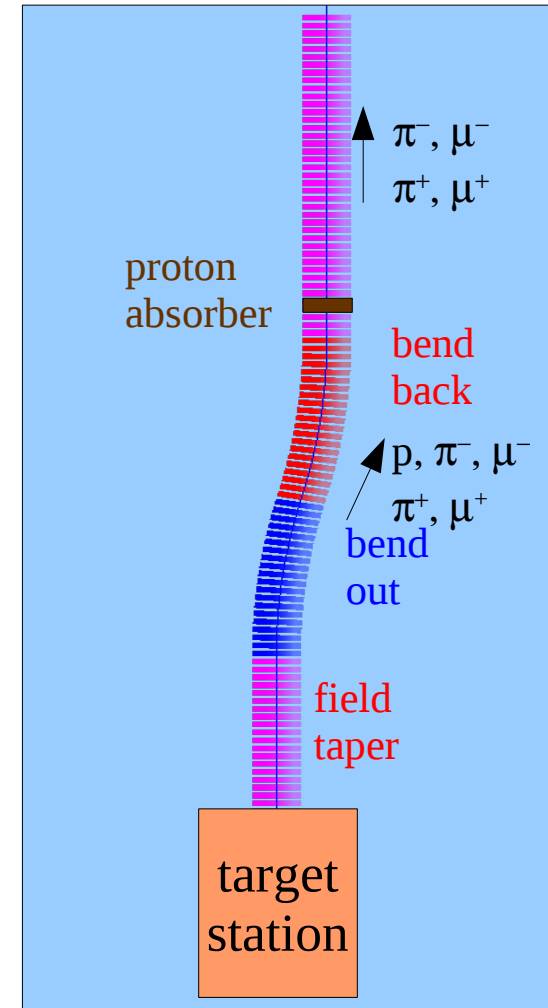

# Phase-Energy Rotation

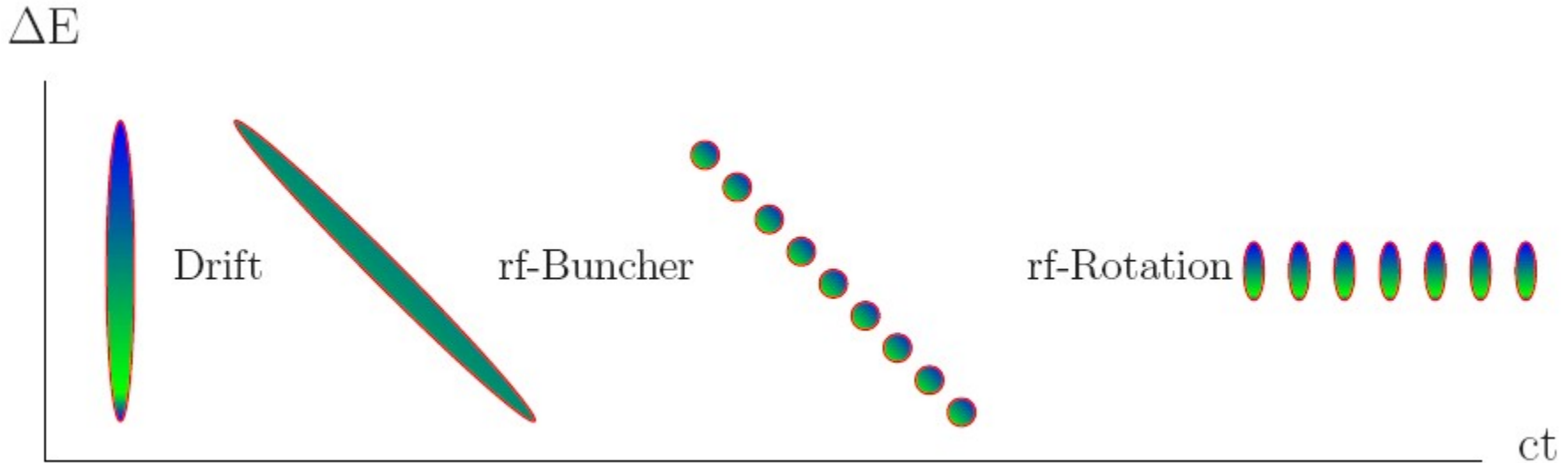

- Beam is very large after pion decay => difficult to control
- Seek to manipulate beam in longitudinal phase space
  - Turn energy spread into a time spread
  - Introduce microbunches to enable higher RF frequencies
    - Higher RF gradients
- Allow beam to drift to develop energy time correlation
- Apply RF phased so that front of beam gains more energy than back

# Muon Ionisation Cooling

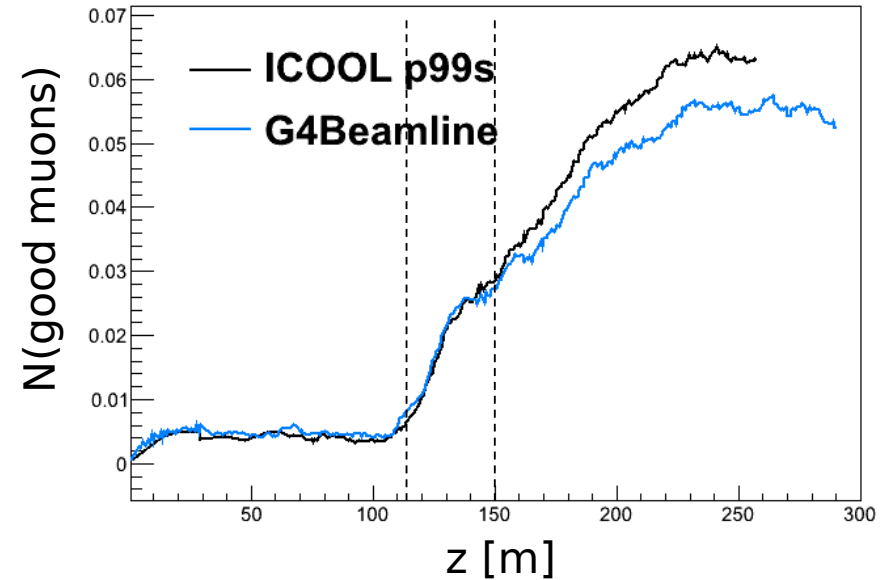
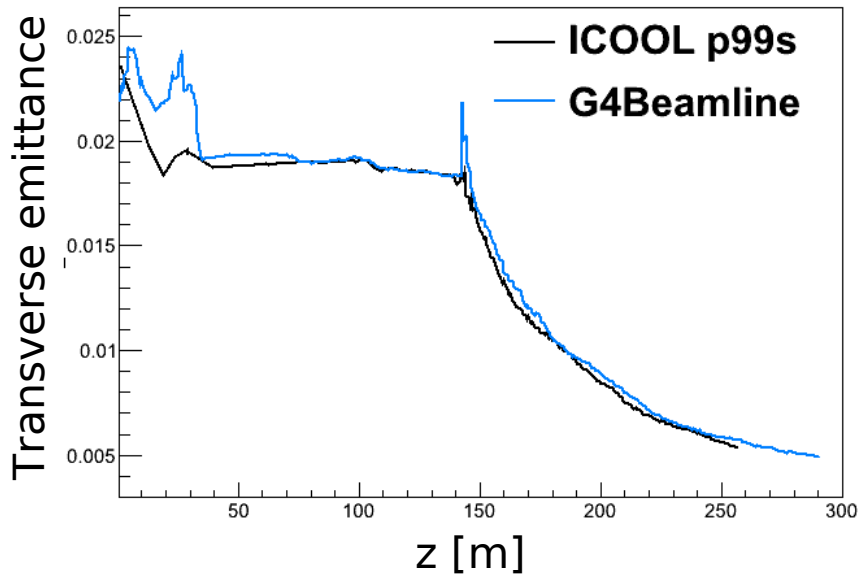

- We have controlled the beam longitudinally – what about transverse?
  - Only technique competitive with muon lifetime is “ionisation cooling”
  - Never before been demonstrated
    - MICE -> Proof of Principle ionisation cooling experiment
  - How does it work?

# 4D Ionisation Cooling

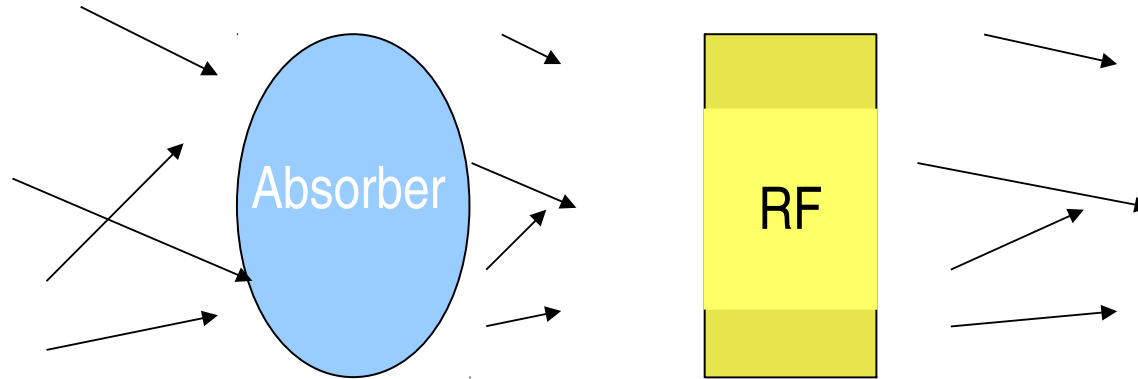

- 4D (transverse) cooling achieved by ionisation energy loss
  - Absorber removes momentum in all directions
  - RF cavity replaces momentum only in longitudinal direction
  - End up with beam that is more straight
- Stochastic effects ruin cooling
  - Multiple Coulomb Scattering increases transverse emittance
  - Energy straggling increases longitudinal emittance



# Compare-absorber vs absorber+chicane



This compares absorber only (10cm Be) to chicane (BSOL) + absorber

1.0 GeV/c

0

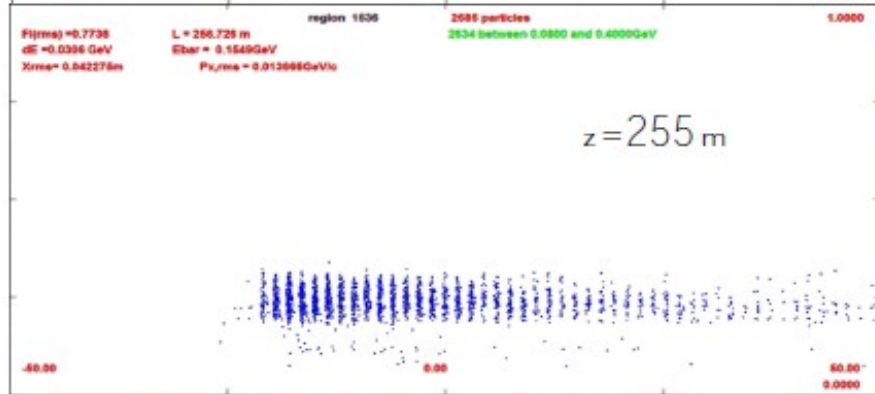
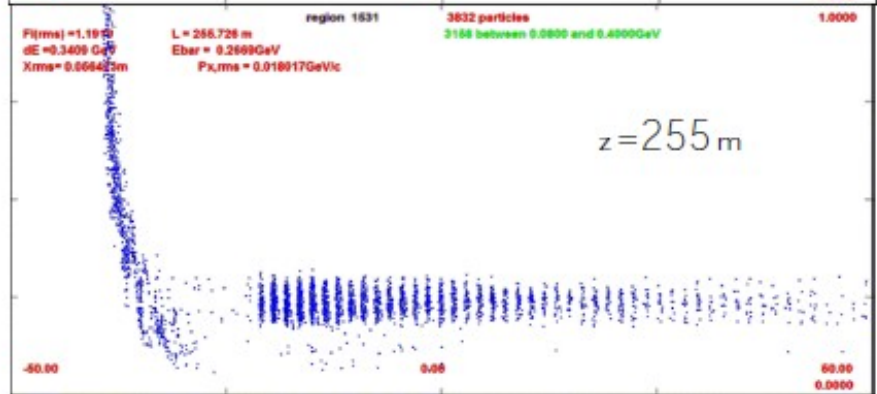
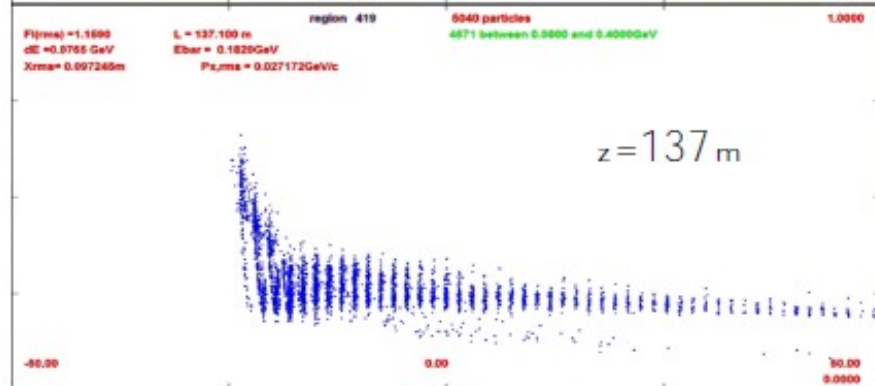
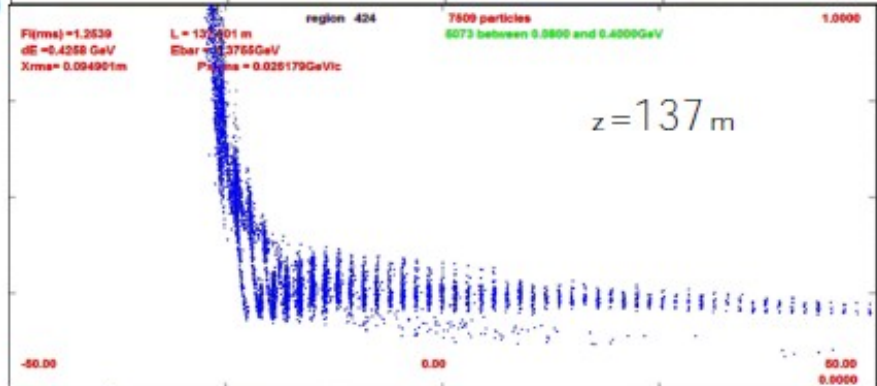
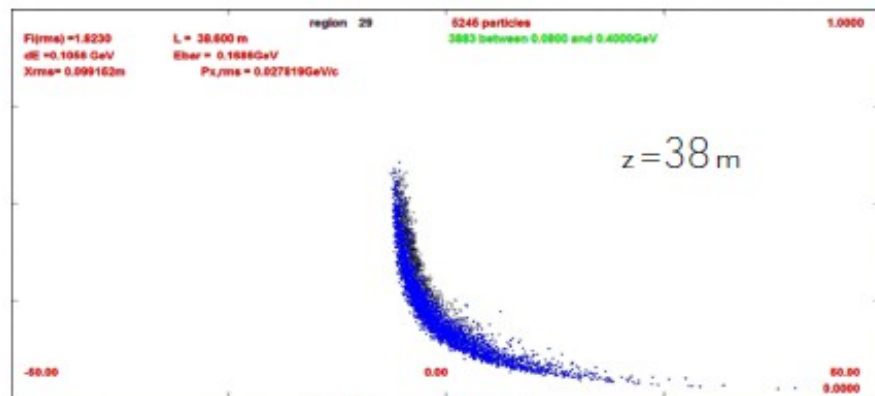
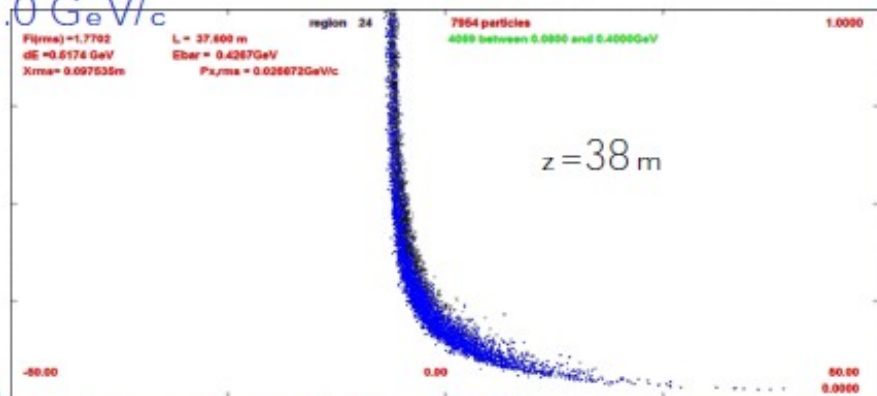

# Time-energy distributions



- Now watch the movie
  - Design including chicane/proton absorber
- Look out for
  - Z=30 m - 40 m we have collimation of particles with  $p > \sim 600$  MeV/c in the chicane
  - Z = 40 m we have a drop in momentum from the proton absorber
  - Z = 70 m we start to adiabatically form micro bunches
    - At  $ct=1.5$  m intervals until
  - Z = 103 m we start to phase rotate - dephase the cavities so that the tail sees a +ve voltage and the head sees a -ve voltage
  - Z = 141 m we enter the cooling channel... quite a lot of longitudinal loss here, mostly particles that would have been lost later on anyway
  - In fact we probably end the cooling channel at Z=216 m
    - Usually simulate past the maximum
- Note low energy, large  $ct$  is the tail of the bunch
  - small  $ct$ , high energy is the head of the bunch
  - i.e. small time  $\Rightarrow$  arrives at the z plane earlier

# Ionisation Cooling Menagerie – Straight Coolers

---





# Cooling Motivation



- Cooling is important to the Neutrino Factory
  - Increases number of muons by factor  $\sim 2$
  - Mitigates challenges in high acceptance accelerator and storage ring design
  - More cooling desirable, but cost optimisation issue
- Cooling is vital to the Muon Collider
  - Need to reduce 6D emittance by several orders of magnitude to get to interesting luminosities
- The aim is to increase phase space density of muon beam
  - Requires non-symplectic transport
    - I.e. cannot be achieved with electromagnetic beam elements
  - Instead use some material to “absorb” density
    - “Heats” material
    - “Cools” muon beam
- A number of cooling channel geometries have been proposed with different merits and problems

# FS2 Channel

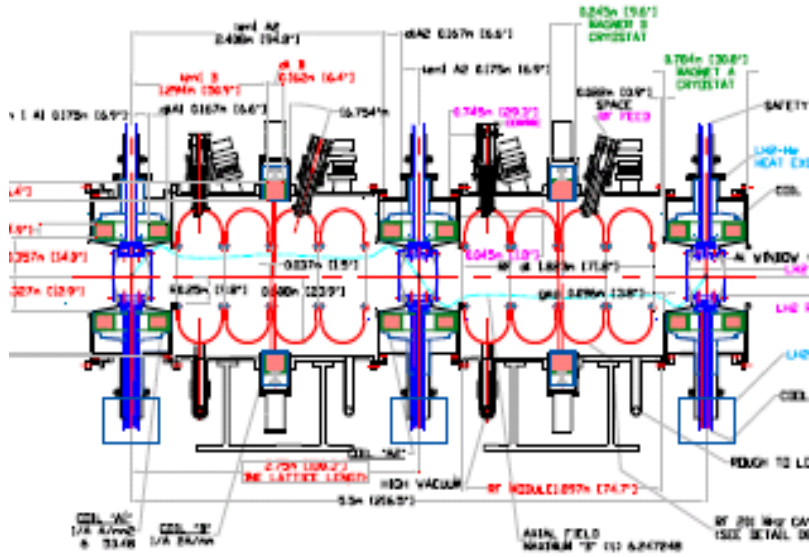

- Highly optimised cooling channel
  - Liquid Hydrogen absorbers
  - 200 MHz RF
  - SFOFO superconducting coils
  - Best performing linear cooling channel
- Challenging engineering
  - Not cost optimised
  - Detailed engineering design

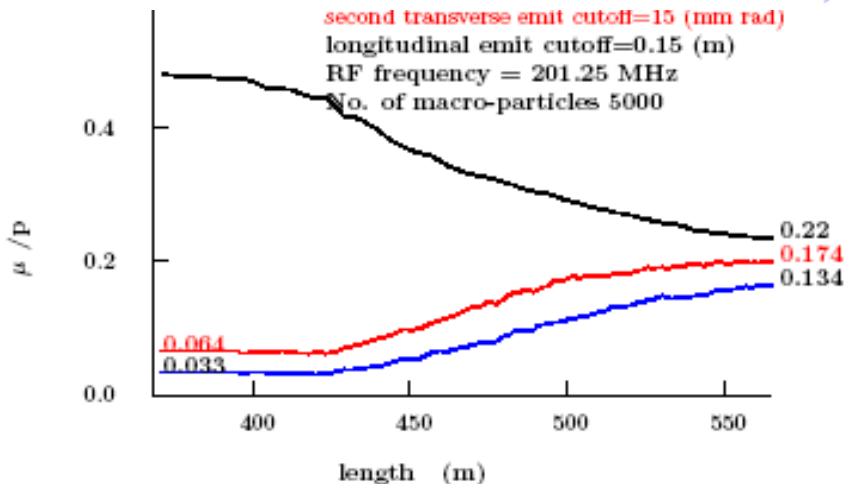

Total Number of  $\mu$   
Number of  $\mu$  that fit in accelerator

# FS2A/IDS Channel

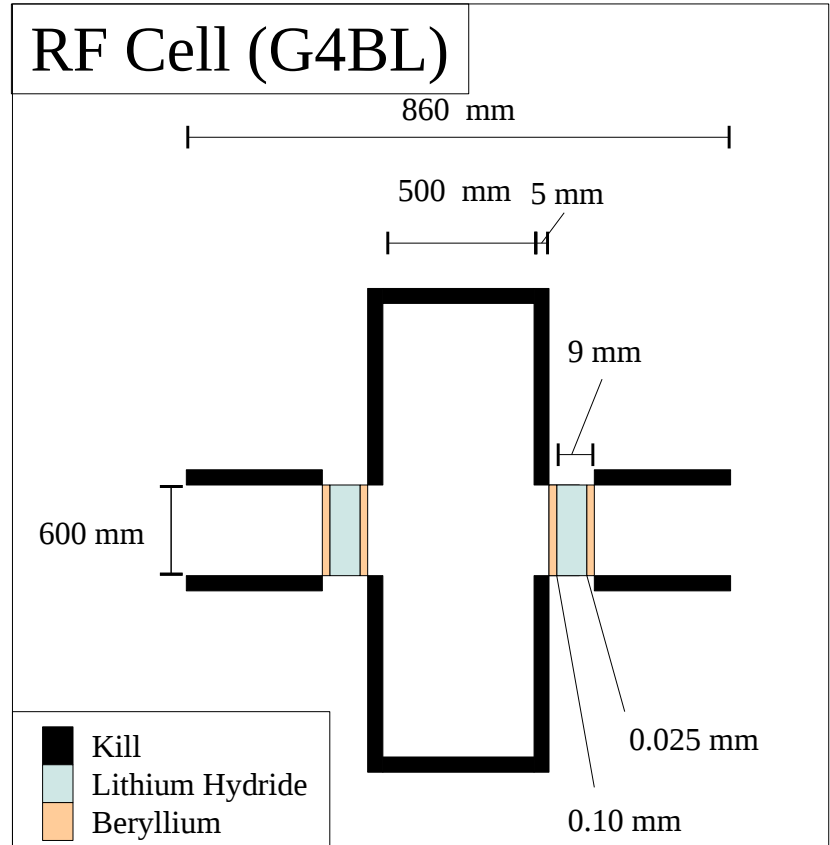
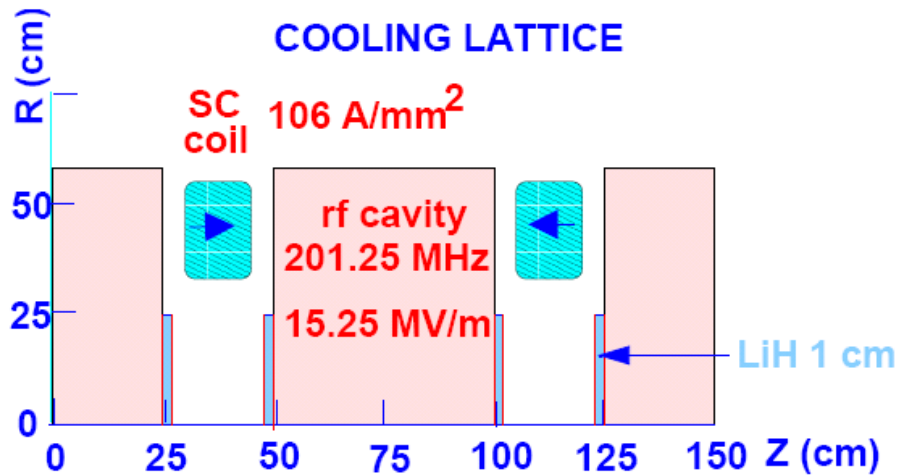

- Cost optimisation points to less aggressive cooling
  - Singlet solenoid lattice
  - Solid Lithium Hydride absorbers coated with Beryllium
    - Electromagnetically seal RF cavities to improve Q-Factor

# B-Induced Breakdown in RF

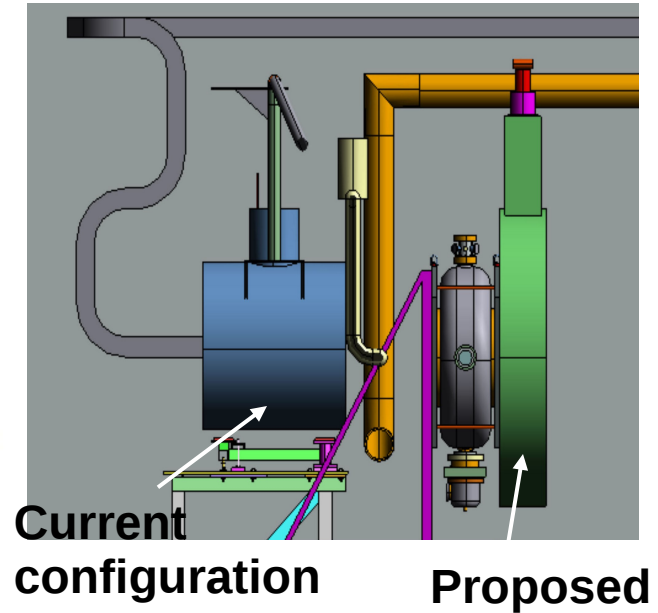
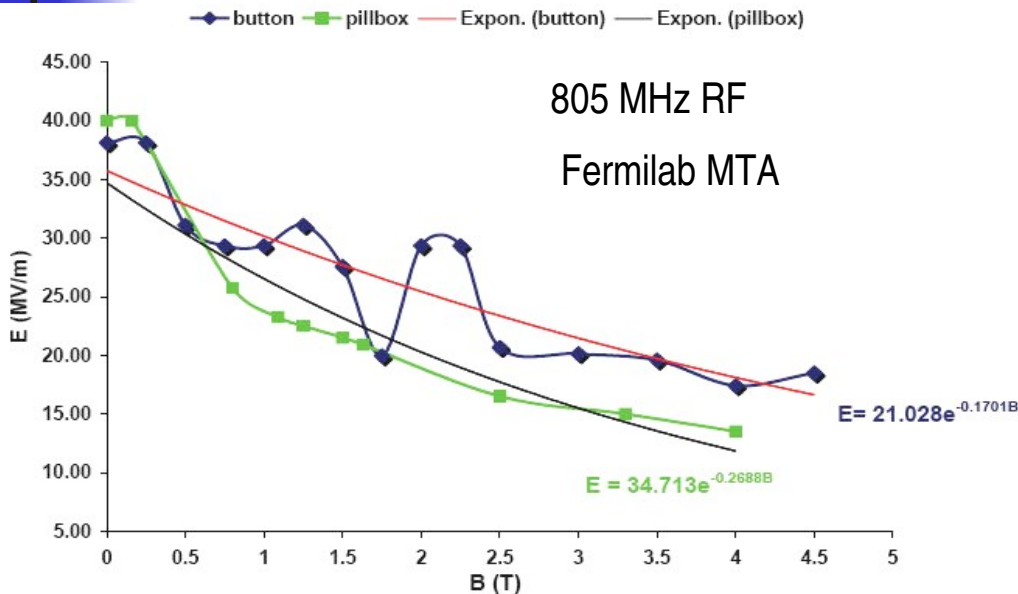

- In most designs, solenoid field overlaps cavities
  - Solenoids have extended fringe fields
  - But this magnetic field induces breakdown in the RF cavities
  - Reduces peak achievable gradient by factor  $\sim 2$
- Investigations under way in the Fermilab Muon Test Area
  - 805 MHz RF tested inside (blue) Lab G magnet
  - Button tests to examine different materials

# Shielded RF

- Increase cell length to remove RF from solenoid fringe fields
  - Add shielding using iron or bucking coils?
  - Try to keep good acceptance and focusing
- Look at cooling section
  - This is where the RF is most limited
  - This is where optics are most demanding
- How well can we cool in this shielded scenario?
- How well can we optimise the cooling lattice?
- Try to keep RF cavities in  $< 0.5$  T fields

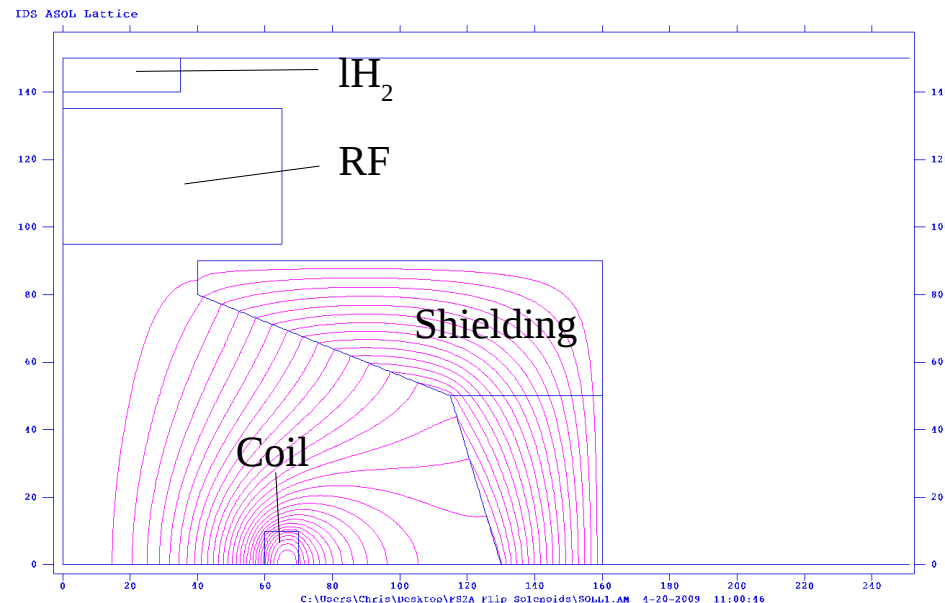
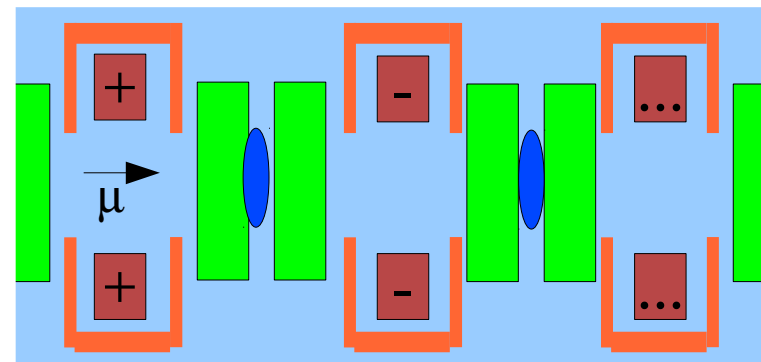



# Transfer Matrix for a Solenoid



$$\mathbf{M}_2(dz) = \mathbf{1} + \begin{pmatrix} 0 & -1/(p\beta_{rel}^2\gamma_{rel}^2) & 0 & 0 & 0 & 0 \\ 0 & 0 & 0 & 0 & 0 & 0 \\ 0 & 0 & 0 & 1/p & B_0/2p & 0 \\ 0 & 0 & -B_0^2/4p & 0 & 0 & B_0/2p \\ 0 & 0 & -B_0/2p & 0 & 0 & 1/p \\ 0 & 0 & 0 & -B_0/2p & -B_0^2/4p & 0 \end{pmatrix} dz.$$

- What is a linear resonance?
- What is criterion for linear resonance in quadrupole channel?
- What is criterion for linear resonance in solenoid channel?

# Lattice quality

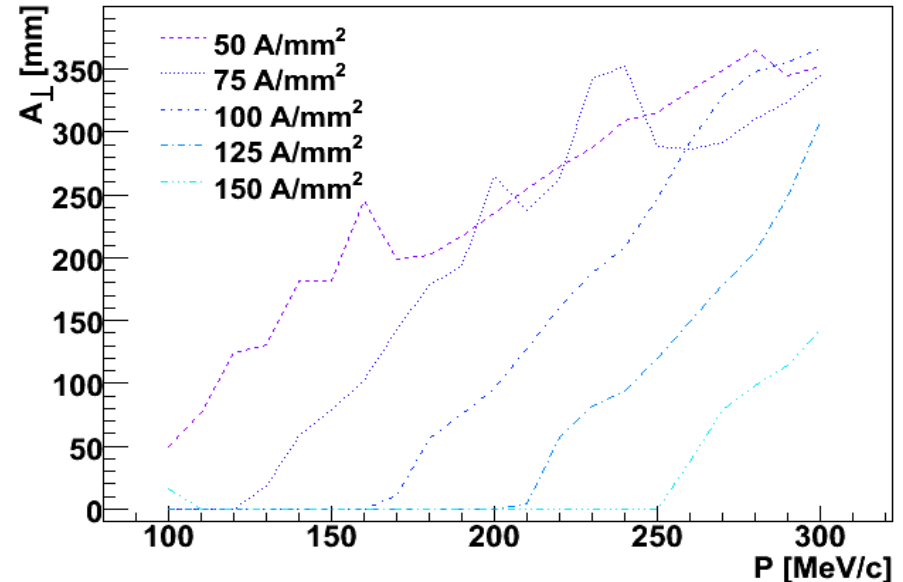
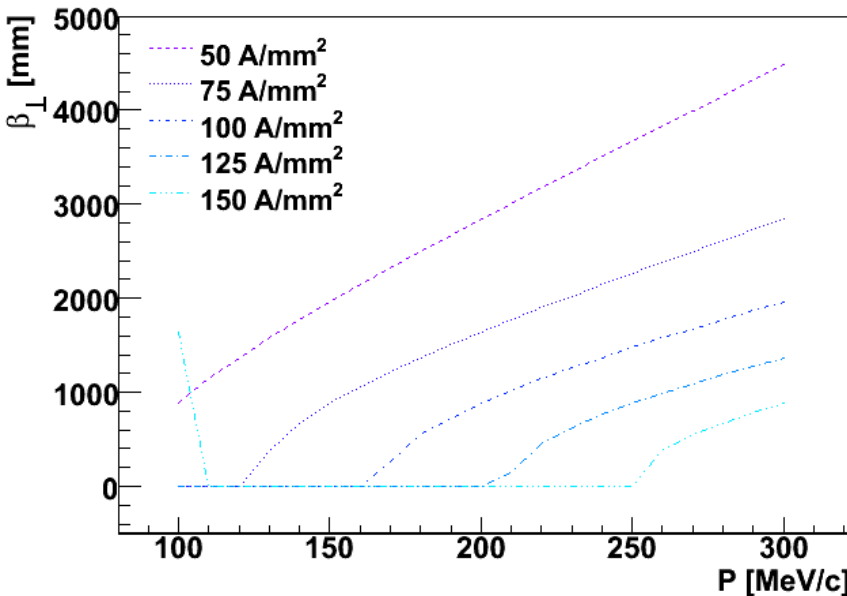

- Two criteria for lattice quality
- $\beta$  function  $\Rightarrow$  how tightly focussed the beam is at the absorber
  - Determines how much cooling we get
  - Require good  $\beta$  function over a large momentum range
- Acceptance  $\Rightarrow$  the beam emittance that makes it through the lattice
  - Determines how much beam we get through
- Scale as  $\sim \langle B_z^2 \rangle / p$

# $\beta$ vs Cell Length

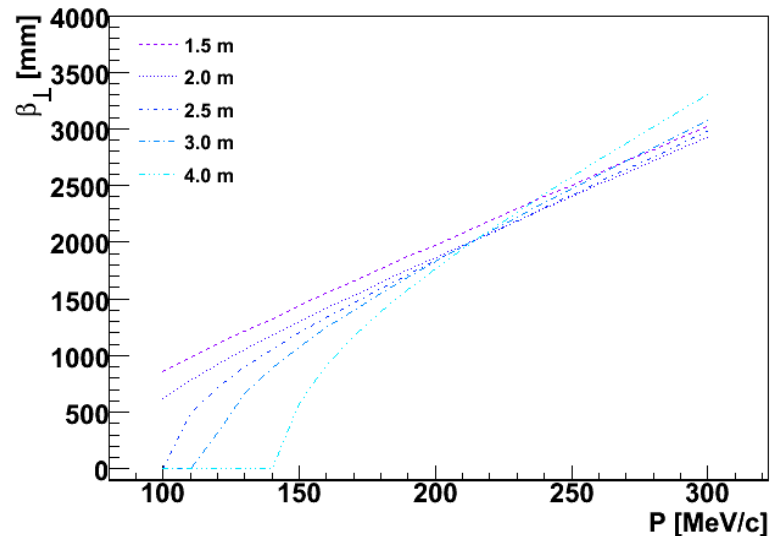

- We want tight focussing on the absorbers for good cooling performance
  - Tight focussing => more cooling
  - Aim for  $\beta < \sim 1500$  mm over  $\sim 150 - 300$  MeV/c (liquid Hydrogen)
- As cell length gets longer d $\beta$ /d $p$  gets worse
  - Making it hard to contain a beam with a large momentum spread
- Keep cell as short as possible
  - To keep  $B_z$  off RF, need to reduce solenoid fringe field

# Lattice Schematic

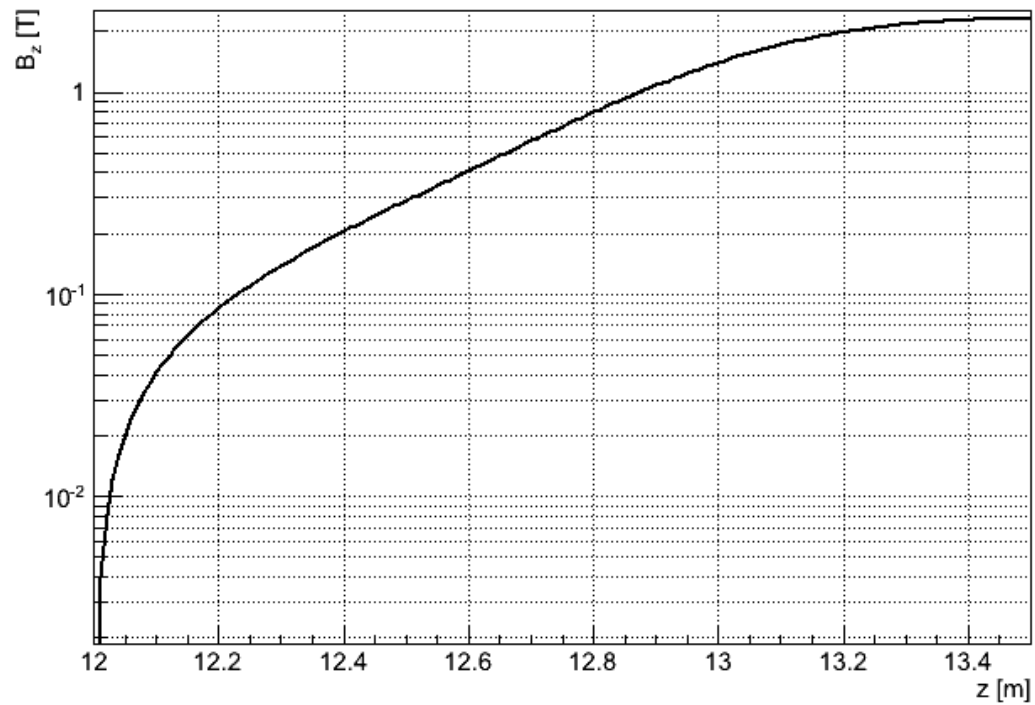

# Capture Performance

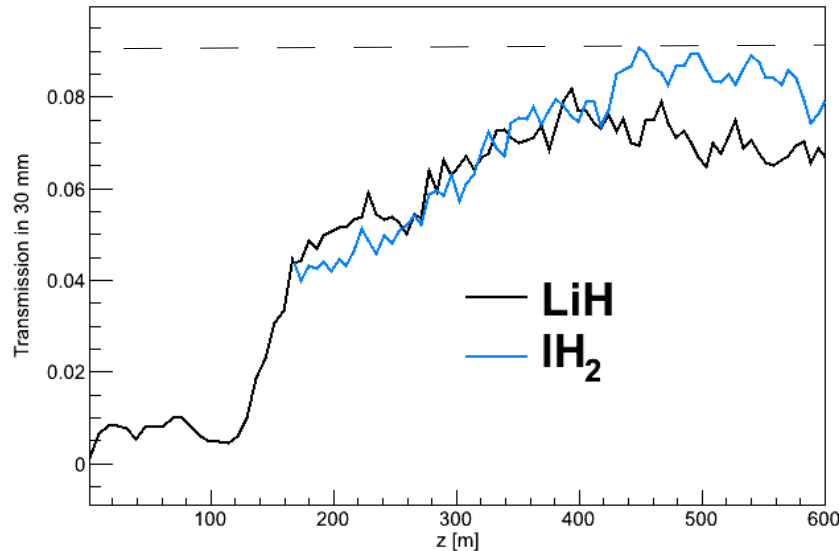

IDR performance

- Transmission inside usual cuts:
  - 30 mm normalised transverse acceptance
  - 150 mm normalised longitudinal acceptance
- Note however momentum cut is
  - $173 < P_z < 373$  MeV/c for low field geometry
  - $100 < P_z < 300$  MeV/c for baseline

# SFoFo Magnetic Lattice

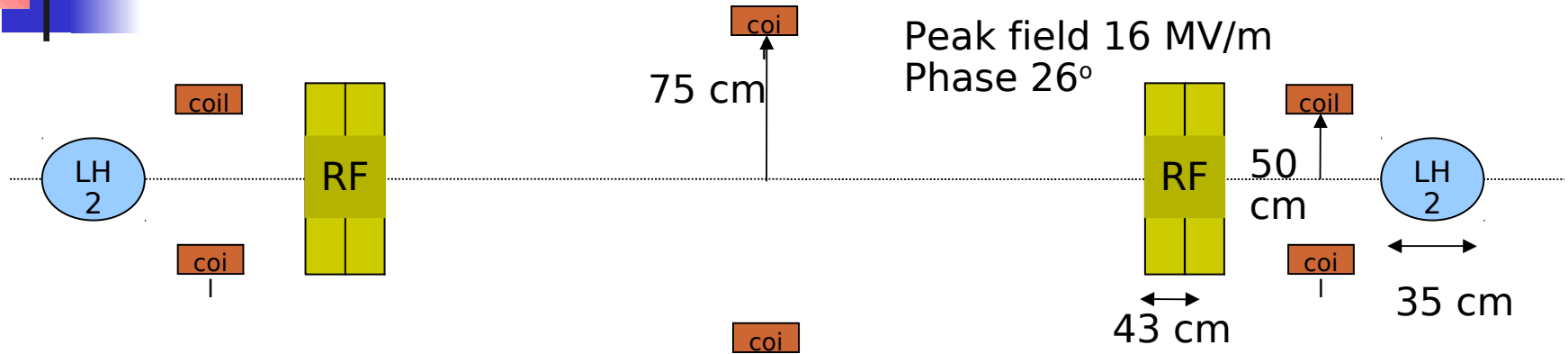

- Optimise magnetic lattice for (in order of priority)
  - Flat  $\beta$  vs momentum to reduce chromatic aberrations
  - Small  $\beta$  at absorbers to improve cooling
  - Small radius beam to reduce scraping ( $\Rightarrow$  small  $\sqrt{\beta}$  )
- Choose to use a 10 m long half-cell
  - FS2 was 2.75 m; FS2A was 0.75 m
- Alternating B-field to conserve canonical angular momentum
  - Make field 0 at absorber so that kinetic angular momentum is 0
  - Then kinetic angular momentum does not change in absorber
  - So canonical angular momentum conserved

# Field and beta function

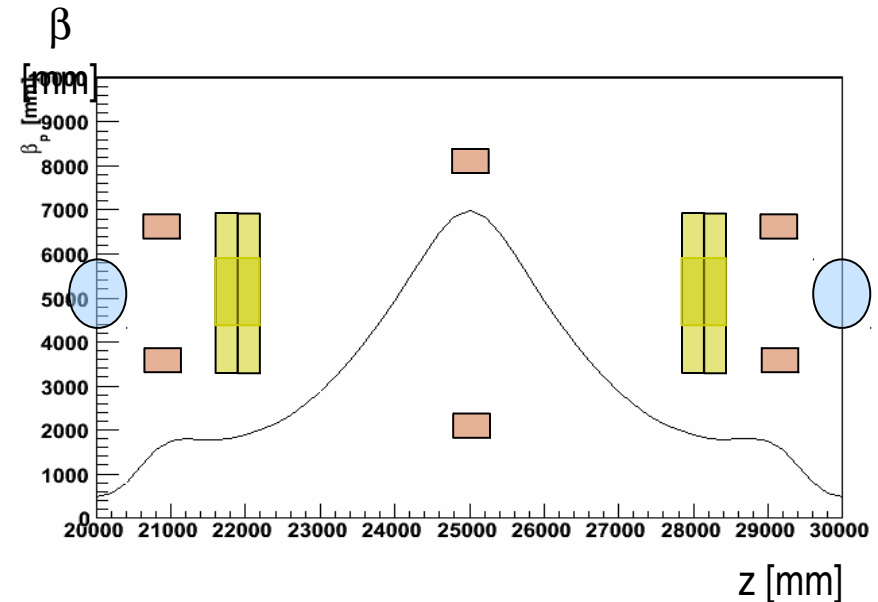
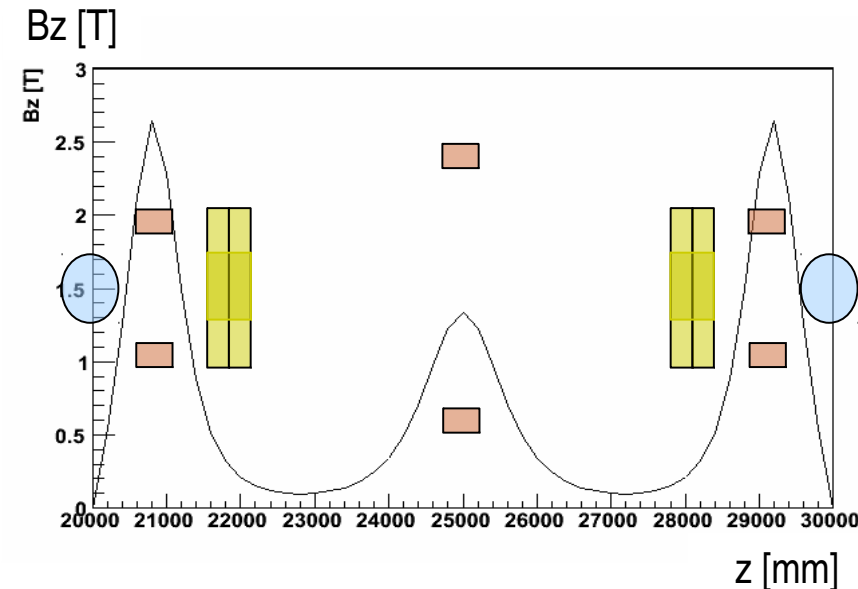

- Convenient shoulders in  $\beta$  function for RF cavities
  - These are still the limiting aperture
  - Scraping here limits performance
- Tight focus at the absorbers improves cooling
  - Lessens the effect of heating due to Multiple Coulomb Scattering
- Large  $\beta$  in centre forces central coil to high radius
  - Becomes more expensive

# Momentum Dependence

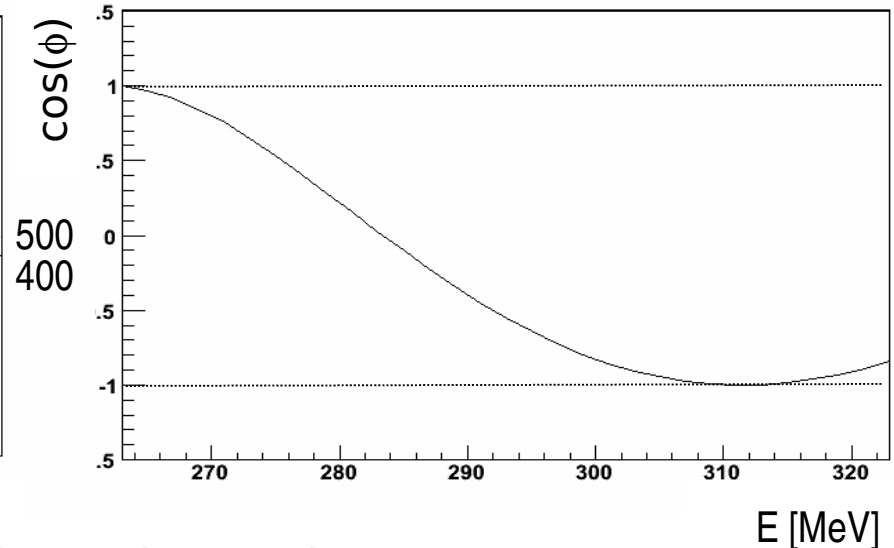
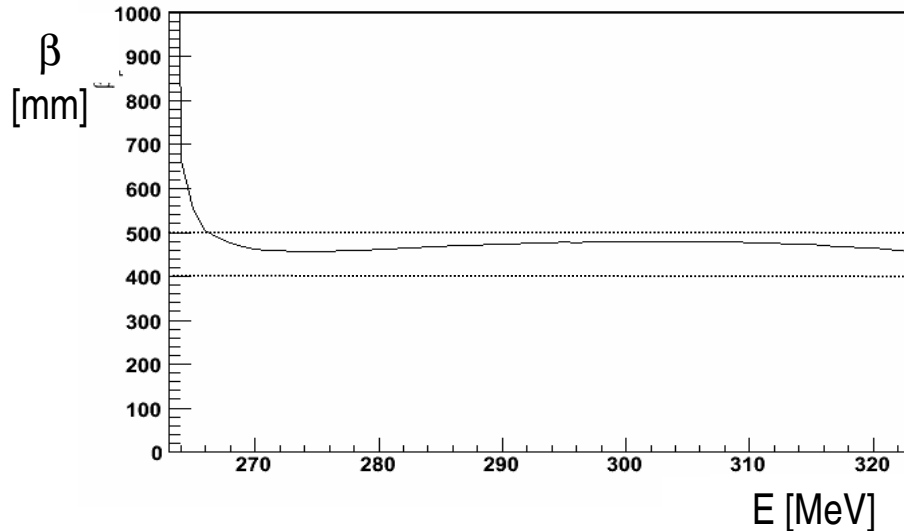

- 2nd order, transverse aberrations dependent only on energy spread
  - Try to remove non-linearities by making  $\beta$  function constant with  $p$
  - Restricts transverse energy spread
- 2nd order longitudinal aberrations dependent on phase advance
  - Leads to correlation between momentum and transverse amplitude
- Resonances when  $\cos(\phi) > 1$ 
  - Lattice is not focussing at these momenta



# Capture Performance

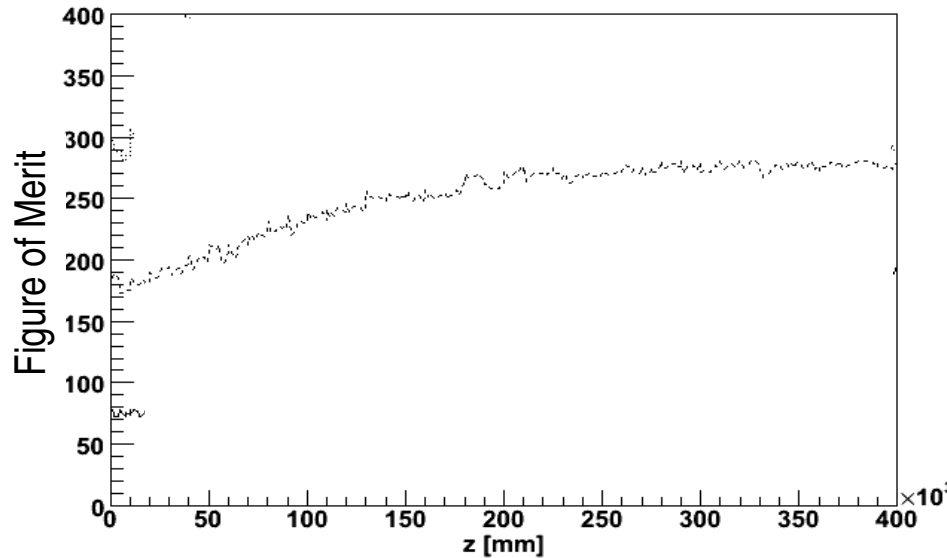

Length [m]	Figure of Merit
80	1.24
160	1.40
240	1.50
400	1.56

- Use same figure of merit
  - Number of  $\mu$  in some accelerator acceptance
  - Cooling performance for long, straight cooling channel only
- Comparable cooling performance to FS2A but still not as good
  - More expensive
  - But RF cavities no longer sit in such strong B-fields



Movie

---





# Ionisation Cooling Menagerie – Recirculating Coolers

---



A decorative graphic in the top left corner consisting of a black crosshair overlaid on a green square, a red square, and a blue square.

# Recirculation - Benefits

---

- Recirculating beam => reuse hardware
  - Makes cooling device cheaper
- Recirculating beam => improved cooling
  - Special technique “emittance exchange”
- However
  - Difficult to get the device to work...

# Dispersive beams

- Introduce bends into beamline
  - Now off-momentum particles follow a different trajectory to on-momentum particles
- Consider cell-by-cell closed orbit
  - Dispersion is the distance between the on-momentum closed orbit and an off-momentum closed orbit
    - Normalised to the momentum difference
- Dispersion is a 1st order effect
- In solenoid-dipole channels dispersion is  $2D$ 
  - Rotation between  $x$  and  $y$  turns an offset in  $x$  into an offset in  $y$

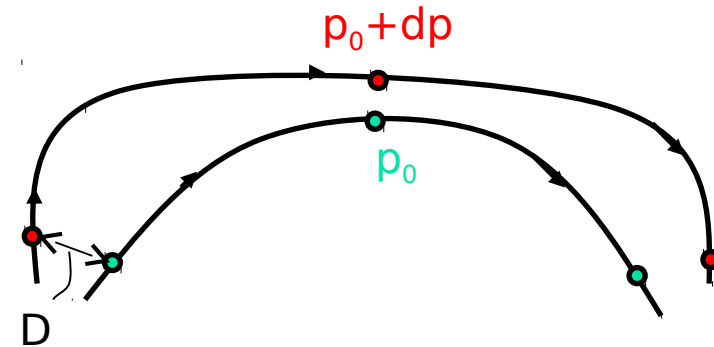

# Emittance Exchange

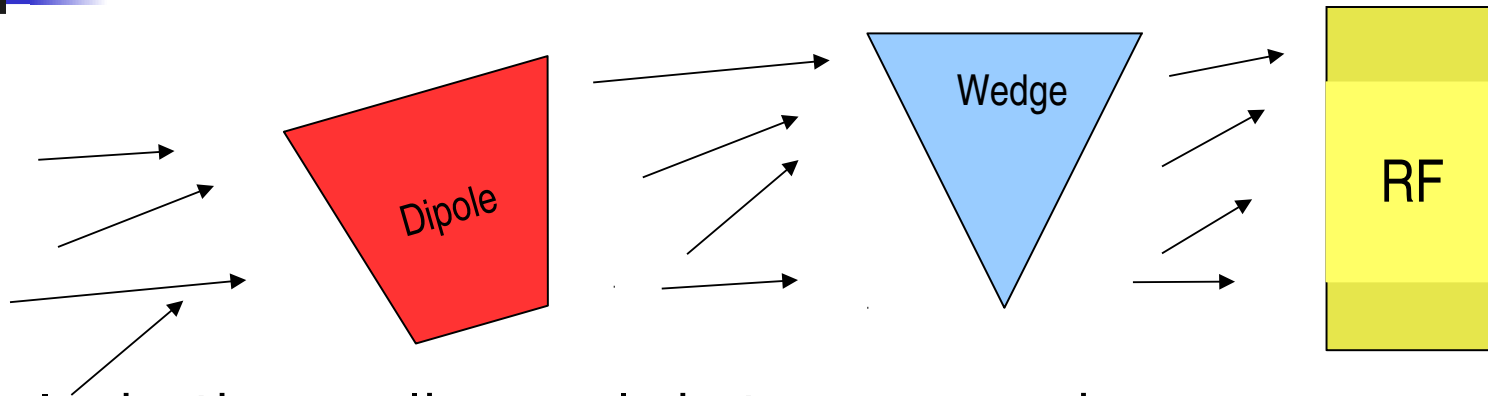

- Ionisation cooling cools in transverse phase space
  - But longitudinal emittance is also large
  - It would be useful to cool in longitudinal and transverse phase space
- Emittance exchange takes emittance from longitudinal phase space to transverse
  - Introduce dispersion => higher energy muons have larger radius
  - Wedge absorber takes more energy from large radius muons
- This is a shear in x-E phase space
  - Does not cool the beam (to 1st order)
- But together with transverse cooling provides 6D cooling

# Ring Cooler

- RFoFo cooler makes bending field using tilted coils
  - Ring circumference 33 m
- Improves number of muons into small acceptance by  $\sim 100s$
- But a number of challenges
  - Injection is highly challenging
  - Heat load on absorbers is demanding
  - RF breaks down in high Bz

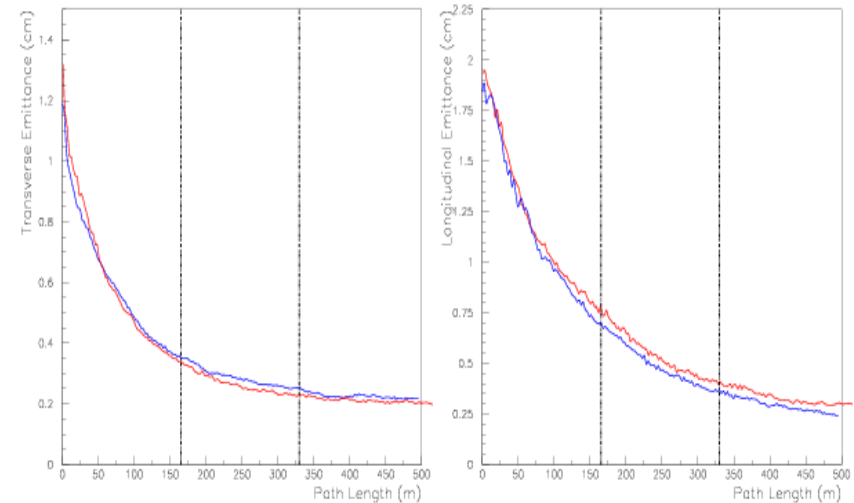
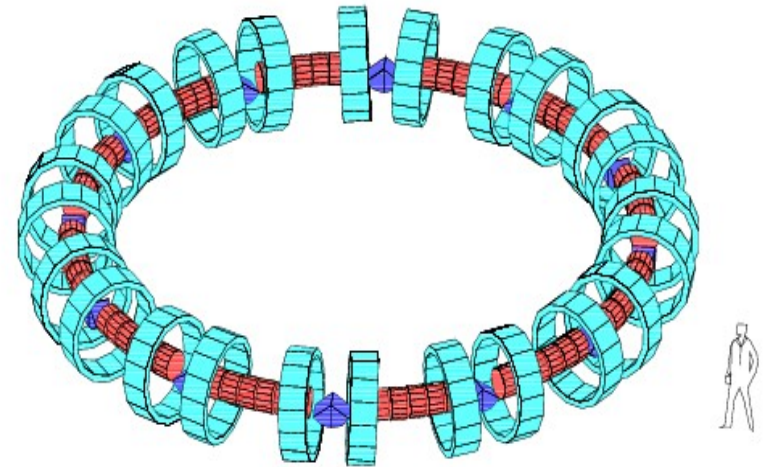

# Guggenheim Cooler

- Pull ring out into a helix
  - Solve absorber heating
  - Solve kicker issue
- Need B-shielding between floors
- Leaves RF sitting in high Bz
- Performance comparable to ring
  - But need to buy much more hardware \$\$
  - Need one for each sign

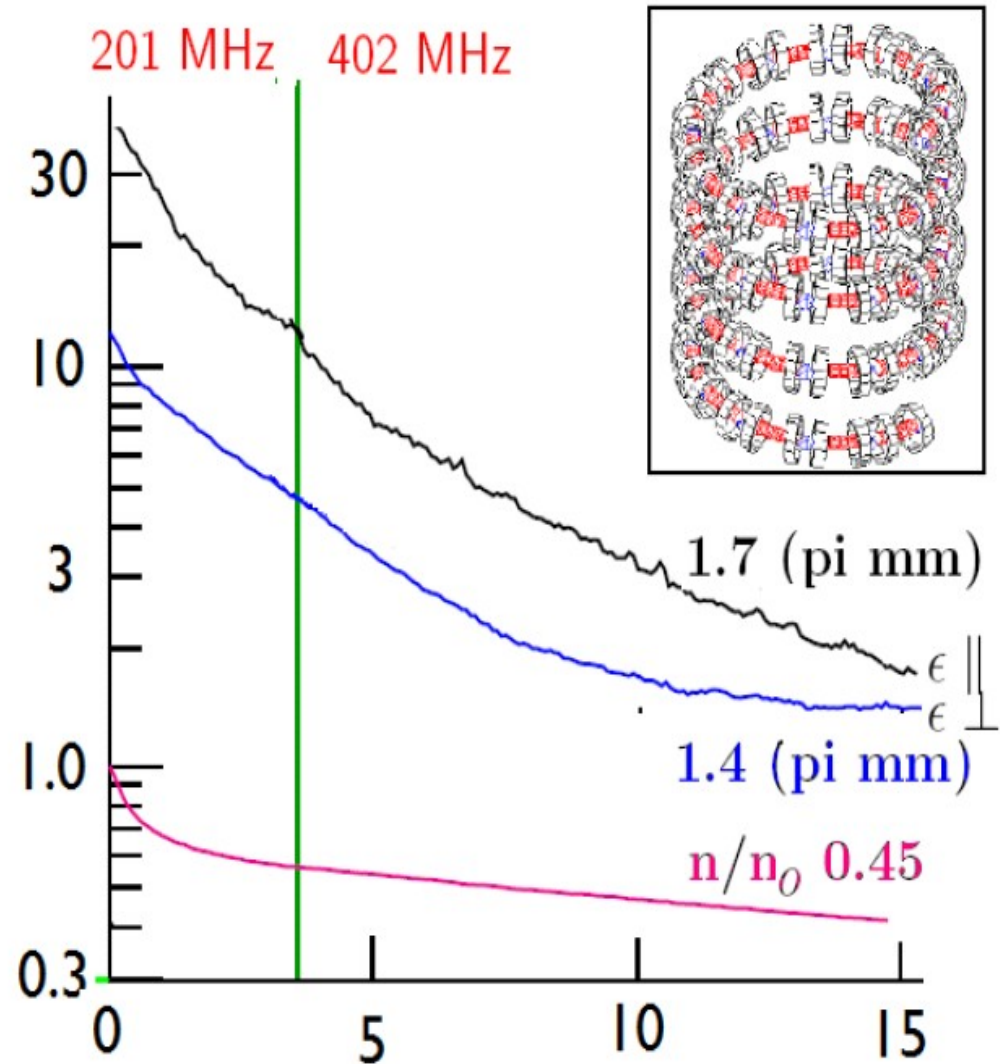



# Helical Cooler

- Change aspect ratio of the Guggenheim
  - May make Guggenheim more compact
  - RF cavities built into the magnet

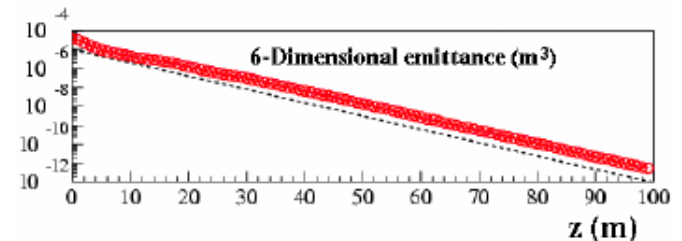
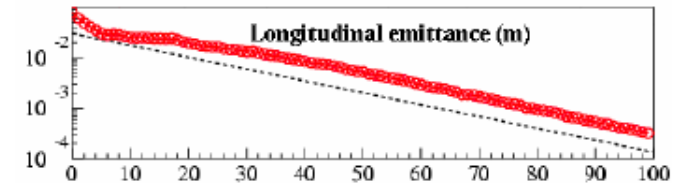
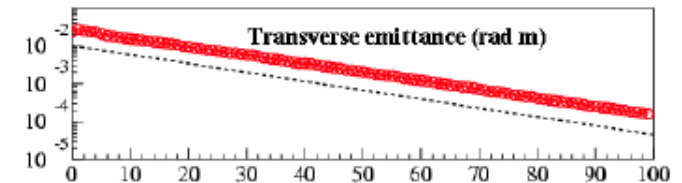
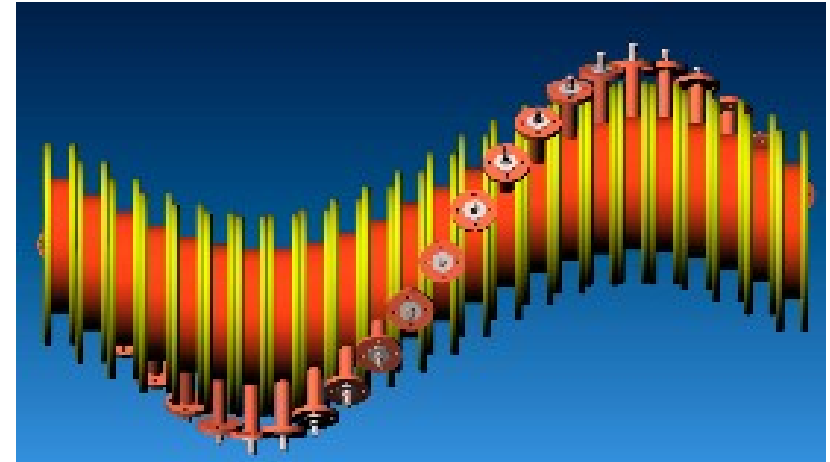

# “High Emittance” Muon Collider

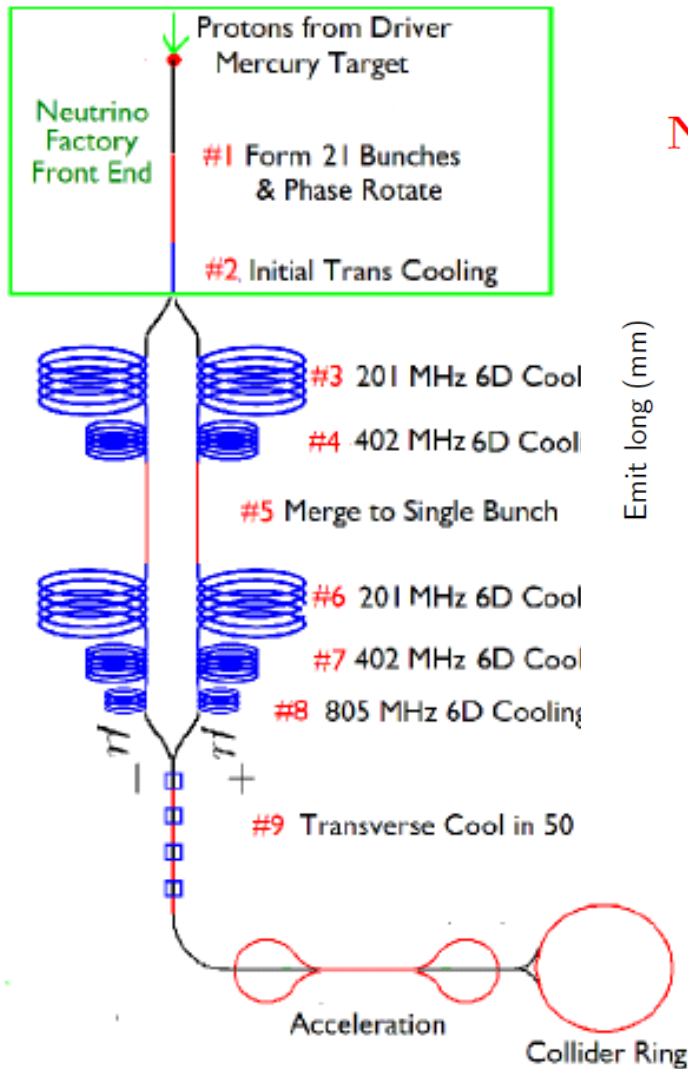

## New 6D cooling with less exchange

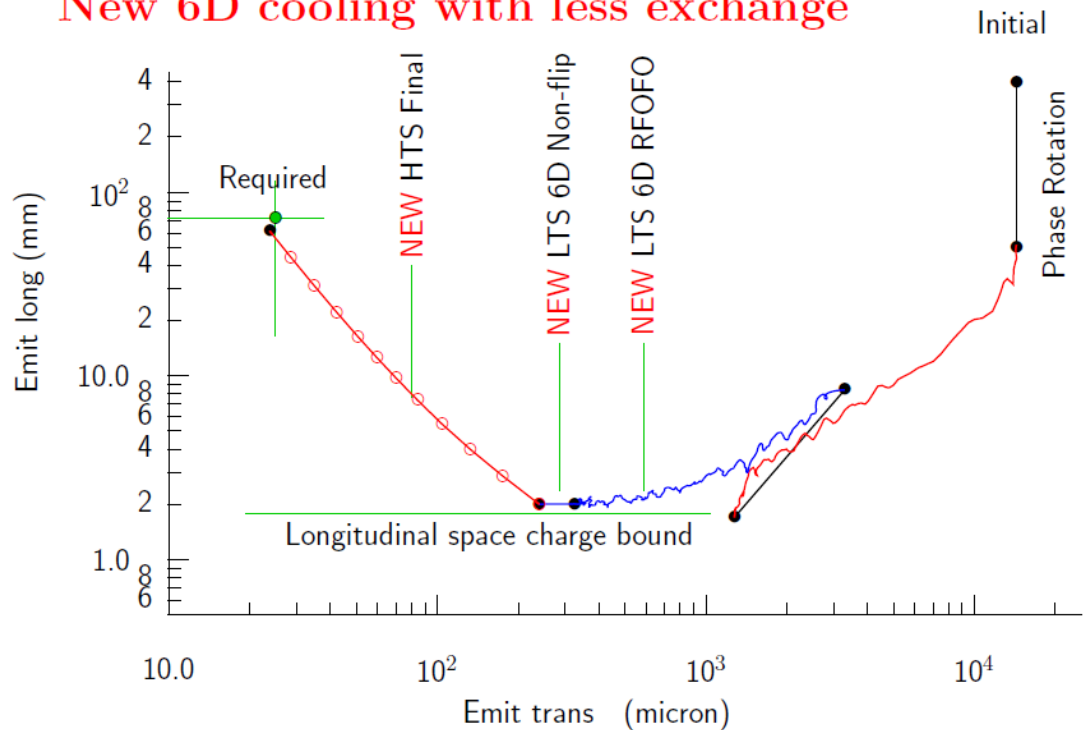



# Muon Ionisation Cooling Experiment

---



# MICE 4D Cooling PoP



- Proof of principle muon ionisation cooling cell
  - Under construction at Rutherford Appleton Laboratory
  - Beamline, AFC, RF, trackers, PID detectors
- Aim to understand engineering risks and prove physics modelling

# Beam Dynamics



- MICE designed to run at a number of different settings
  - Different momenta
  - Field flipping and non-flipping
  - Different focussing at absorbers
  - Different absorber materials
  - Different input beams
- Baseline case is 200 MeV
  - $\beta$  tightly focussed at absorbers
  - $B_z = 0$  in absorber material
    - For angular momentum conservation
  - Additional focussing in RF cavities
    - To prevent excessive scraping

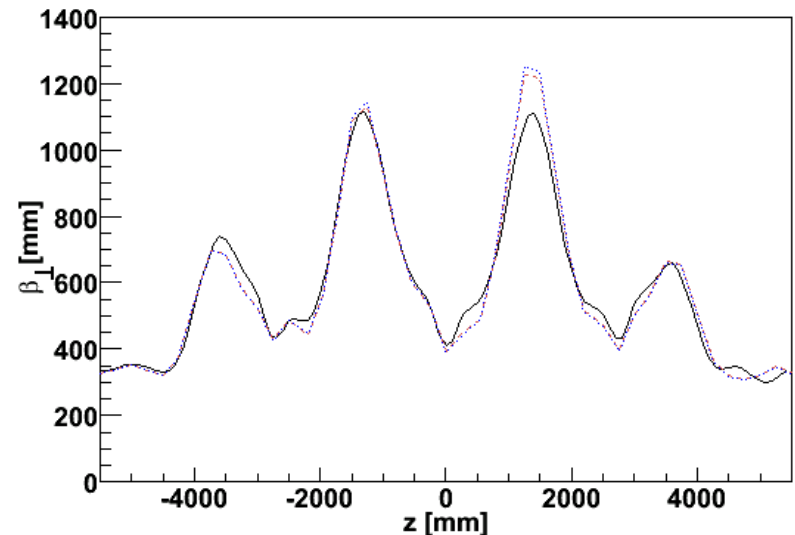
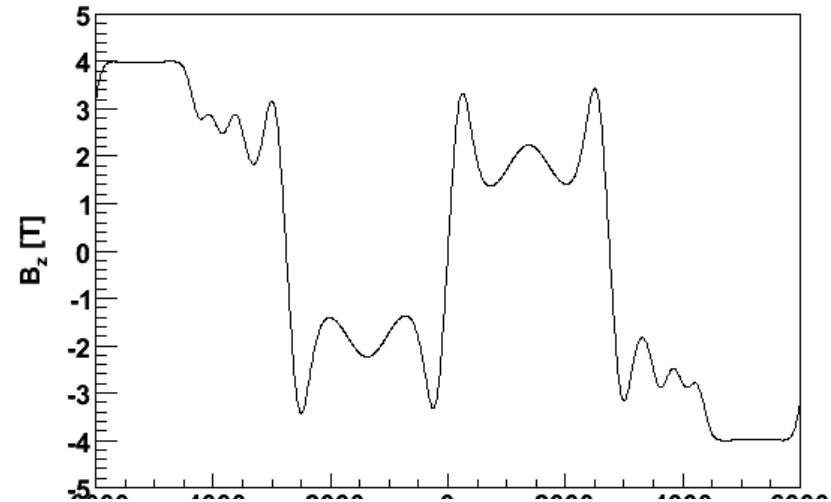

# Momentum Acceptance



- Lattice design for high momentum acceptance
  - Means staying clear of linear resonances
- Understand resonances into Fourier components of on-axis B-field
  - Each resonance controlled by a Fourier Component
- MICE is an “SFoFo-type” lattice
  - Suppress fourier components that would give linear resonances
- MICE has wide acceptance band in range  $150 < P_z < 250$  MeV/c
  - Weak stop band at  $\sim 195$  MeV/c

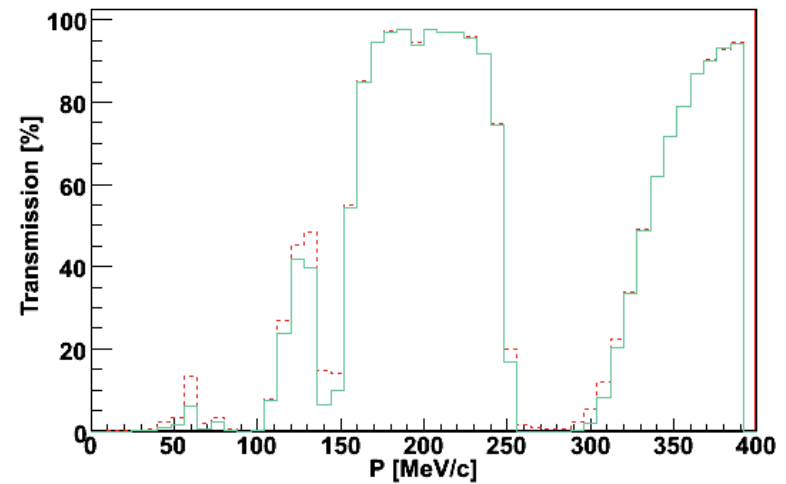
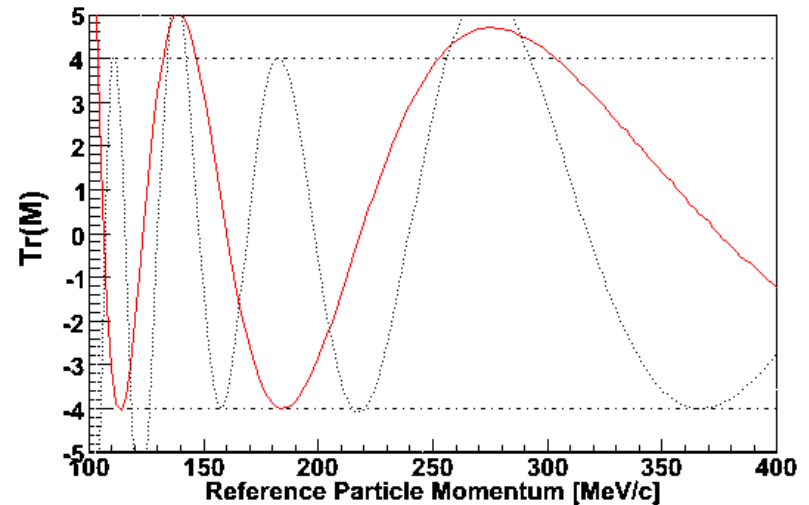

# Cooling Performance



- MICE gives  $\sim 10\%$  emittance change
  - Optical heating
  - Absorber cooling
- Cooling gives an increase in muon density at MICE centre
- Heating gives an increase in muon density at MICE fringe
- Hope that cooling is faster than heating!

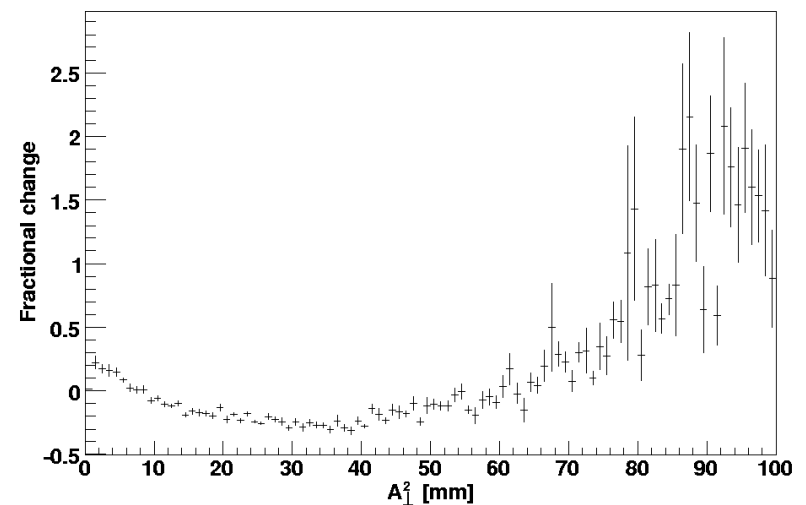
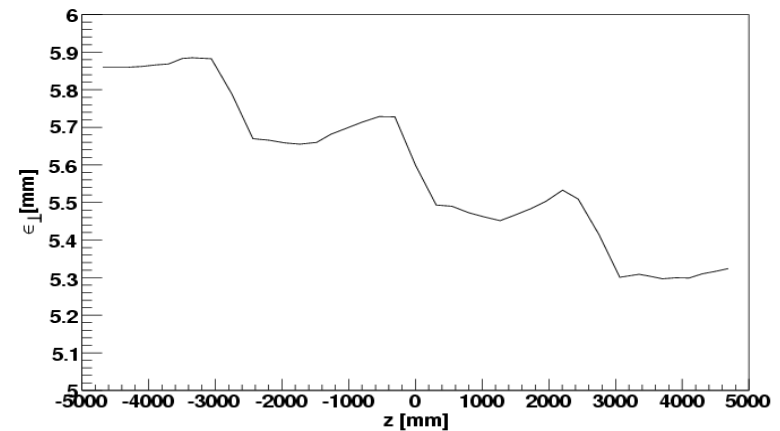

# Measurement Performance



- In emittance measurement  
Detector error is a systematic effect
  - MICE measures beam width etc
  - Errors in position measurement add to beam width measurement in quadrature
  - Given a good knowledge of detectors this error can be removed
  - Gives high precision emittance measurement
- Aim is to measure emittance change to  $\sim 1\%$ 
  - Challenging
  - But simulations indicate it can be done!

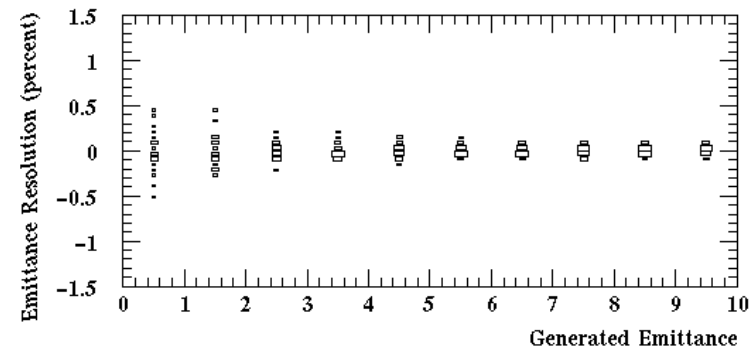
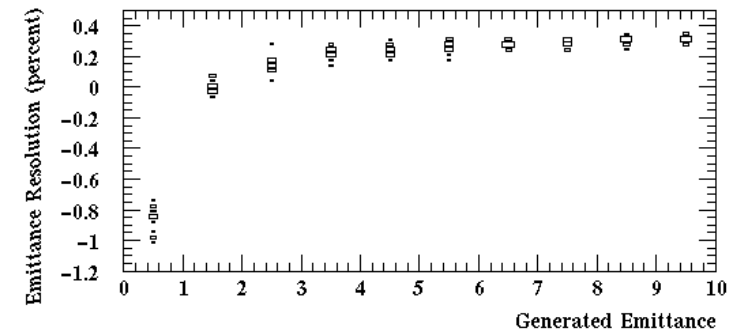
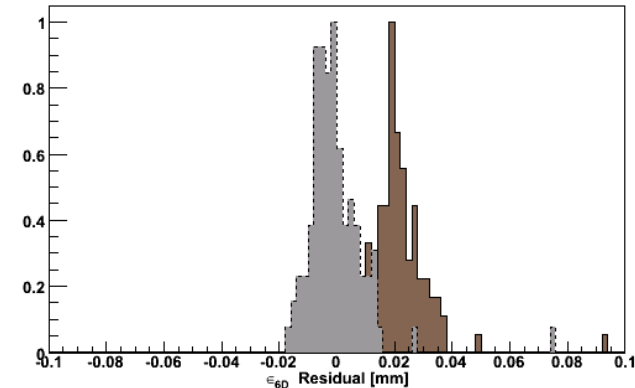



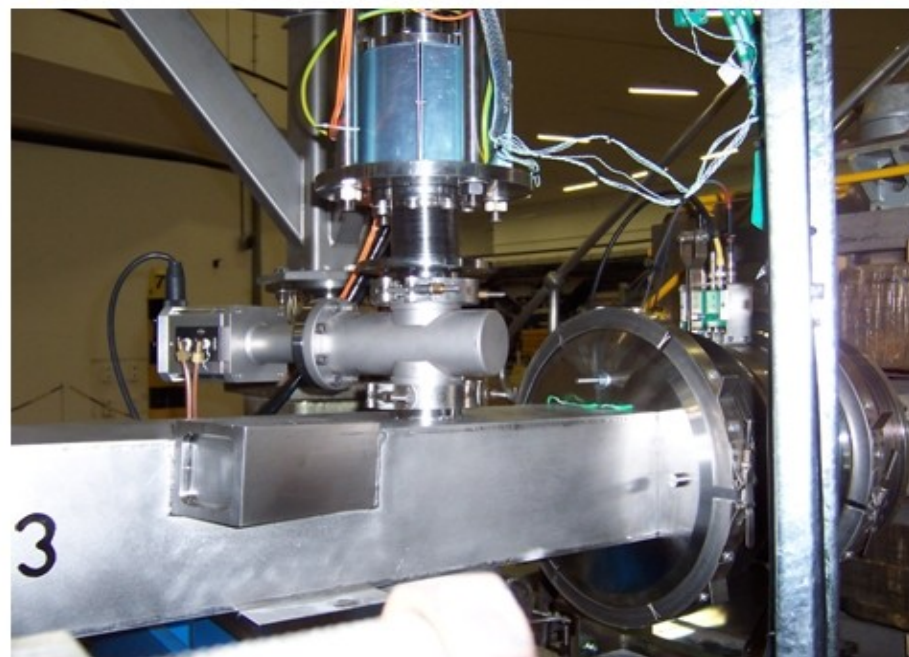
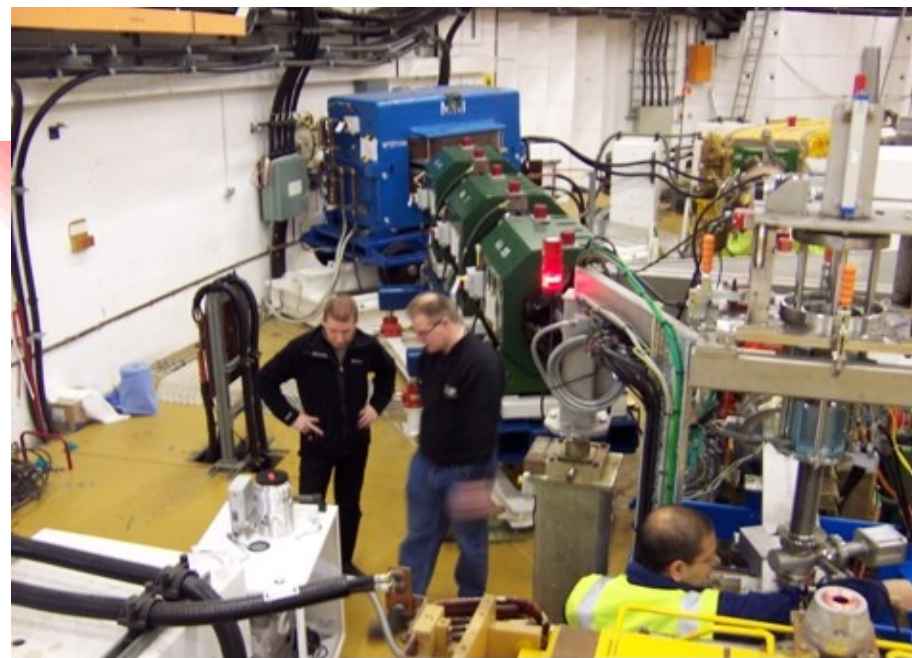

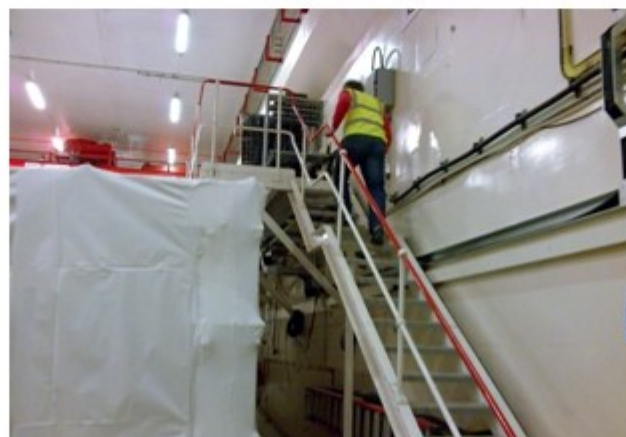
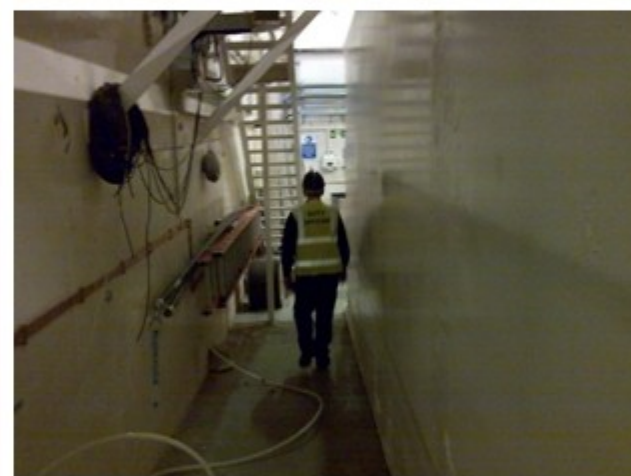

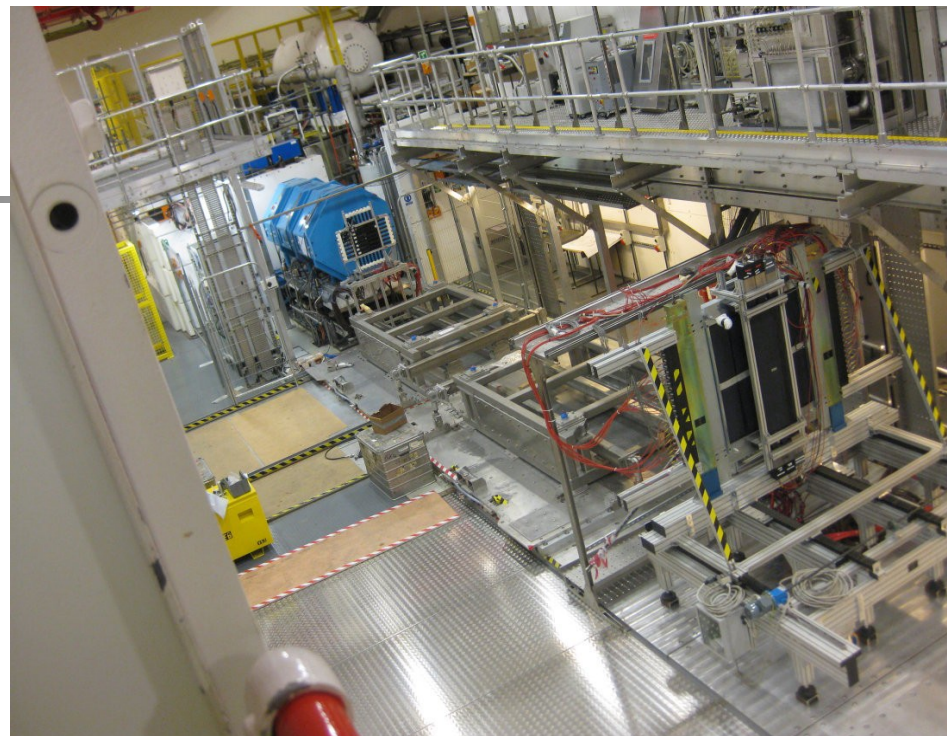
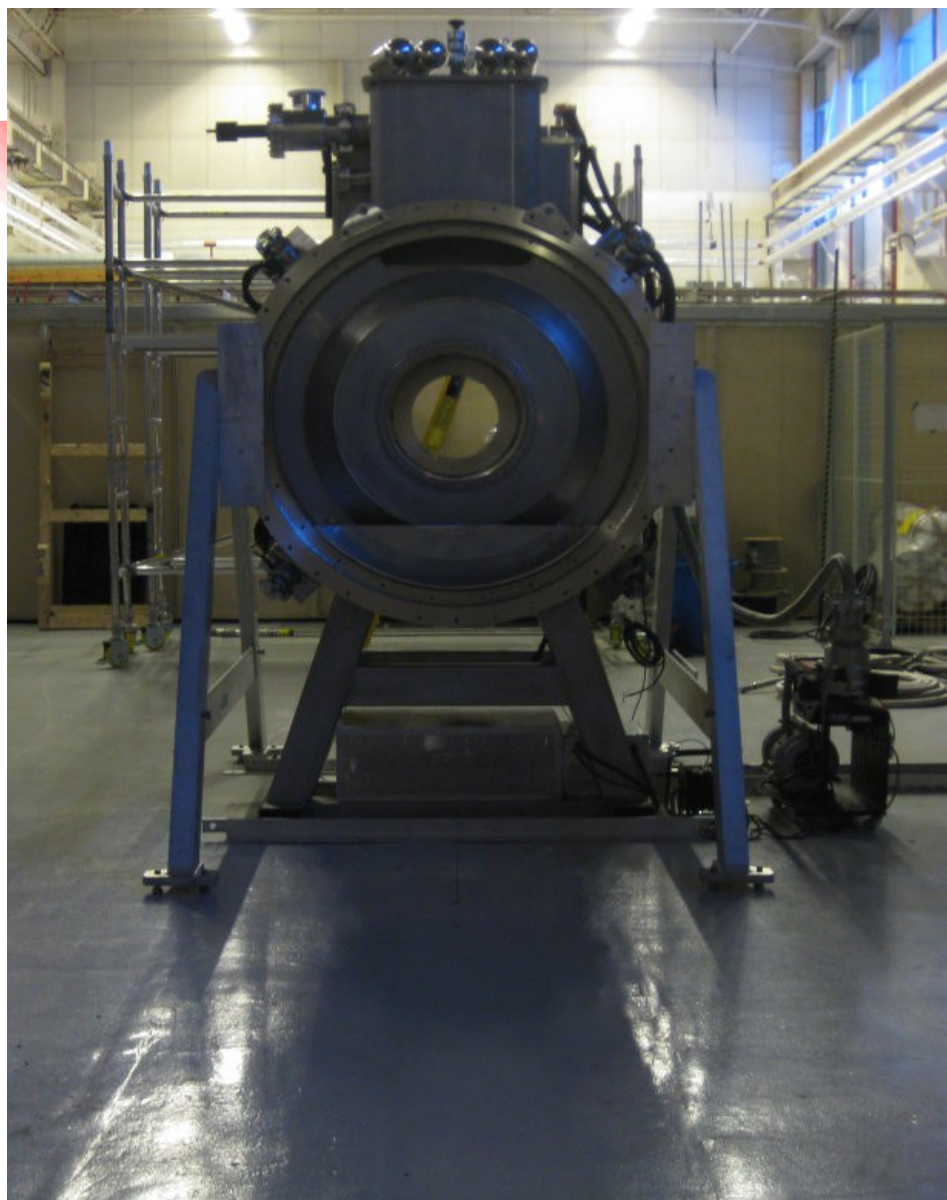



# Conclusions



- Growing interest in large, high energy muon facilities
  - Neutrino Factory -> neutrino oscillations
  - Muon Collider -> energy frontier or Higgs factory
- Such facilities have been made possible by
  - Fast & high acceptance accelerators
  - Revolution in muon cooling conceptual design
- Muon cooling is a challenging technology
  - High acceptance accelerators
  - High gradient RF
  - Superconducting solenoids
- Soon to be proved by experiment
  - MICE construction underway