

**IDS120j WITHOUT RESISTIVE MAGNETS**

**INTRODUCING A DOUBLE WALL Hg POOL VESSEL AND Be WINDOW.  
SC#4 AZIMUTHAL DPD DISTRIBUTION ANALYSIS  
FOR 15.8 g/cc W BEADS IN SHIELDING**

**Nicholas Souchlas, PBL (5/1/2012)**

# IDS120j GEOMETRY: WITH GAPS

\*\*\*\*\*

# SIMULATIONS USING LOWEST GRADE W BEADS IN SHIELDING ( OF 15.8 g/cc )

# SC#1, SC#4 AZIMUTHAL DPD DISTRIBUTION STUDIES FOR 20 cm GAPS SIZE FOR STST IN THE PLACE OF RESISTIVE MAGNETS AND REST OF VOLUME IN Hg POOL VESSEL [INCOMPLETE].

# SC#4 AZIMUTHAL DPD DISTRIBUTION STUDIES FOR 20 cm GAPS SIZE FOR 60% W + 40% He SHIELDING IN THE PLACE OF RESISTIVE MAGNETS AND IN THE REST OF VOLUME IN THE Hg POOL VESSEL.

\*\*\*\*\*

>SIMULATIONS CODE: mars1510 / MCNP

>NEUTRON ENERGY CUTOFF:  $10^{-11}$  MeV

>SHIELDING: 60% W + 40% He ( WITH STST VESSELS)

>PROTON BEAM POWER: 4 MW

>PROTON ENERGY:  $E = 8$  GeV

>PROTON BEAM PROFILE: GAUSSIAN,  $\sigma_x = \sigma_y = 0.12$  cm

**IDS120j: WITH AND WITHOUT RESISTIVE MAGNETS  
( REPLACING RS#1-5, SH#1A, SH#1B, UPPER HALF OF Hg POOL WITH STST )**

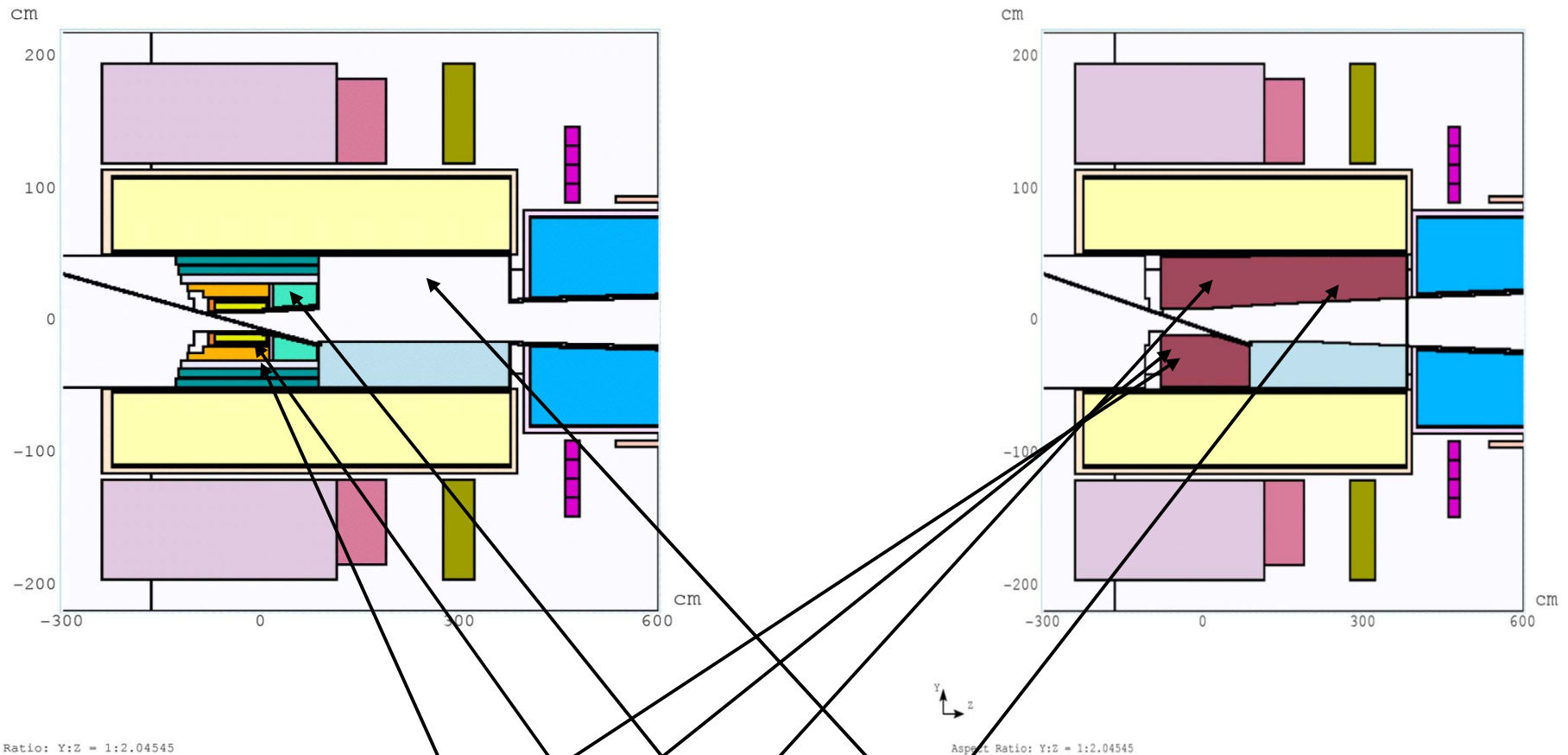

**RESISTIVE MAGNETS, SH#1A/SH#1B, UPPER HALF OF Hg POOL VESSEL ARE NOW OCCUPIED WITH STST. THE VOLUME WILL BE “CARVED” TO ACCOMODATE THE Hg PIPE, Hg POOL DRAINING PIPES, COOLING HOLES etc. THIS APPROACH WILL ENSURE PRECISE PLACEMENT OF COMPONENTS.**

**IDS120j: AZIMUTHALLY AVERAGE DPD MARS PLOTS, FOR 15.8 g/cc W BEADS, WITH (LEFT) AND WITHOUT (RIGHT) RESISTIVE MAGNETS . (USING STST IN THE PLACE OF RS#1-5, SH#1A,SH#1B, REST OF Hg POOL NOT OCCUPIED BY Hg)**

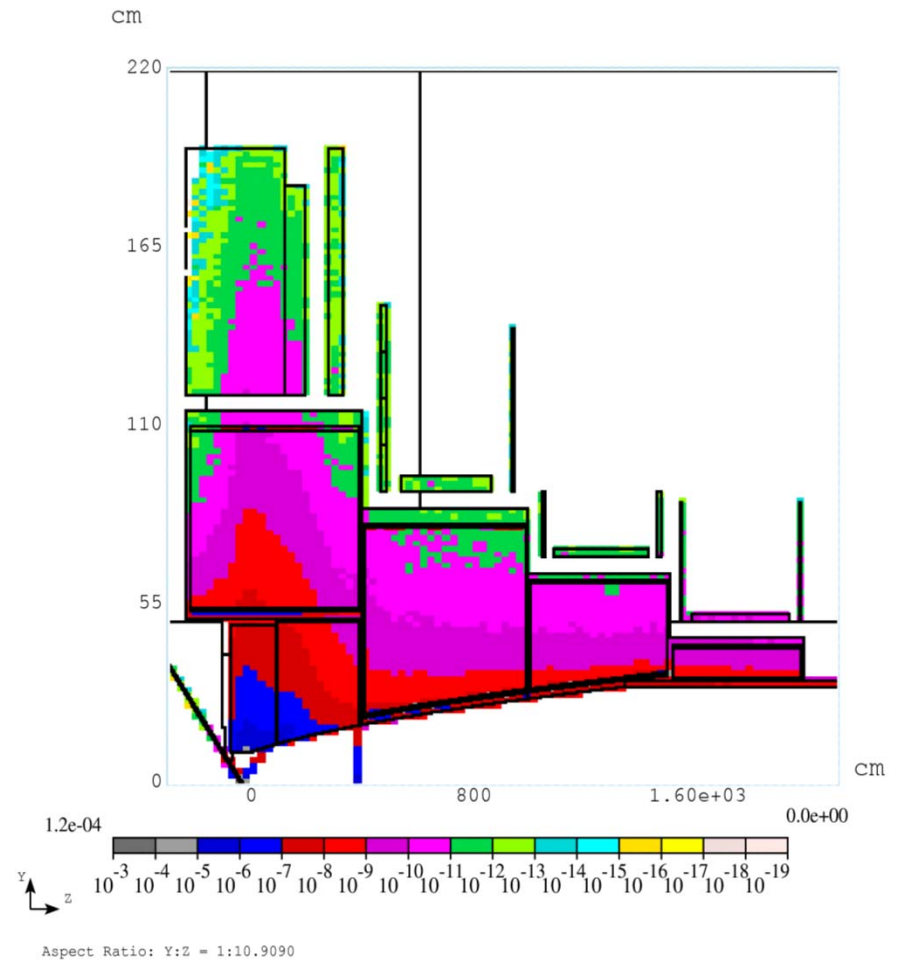
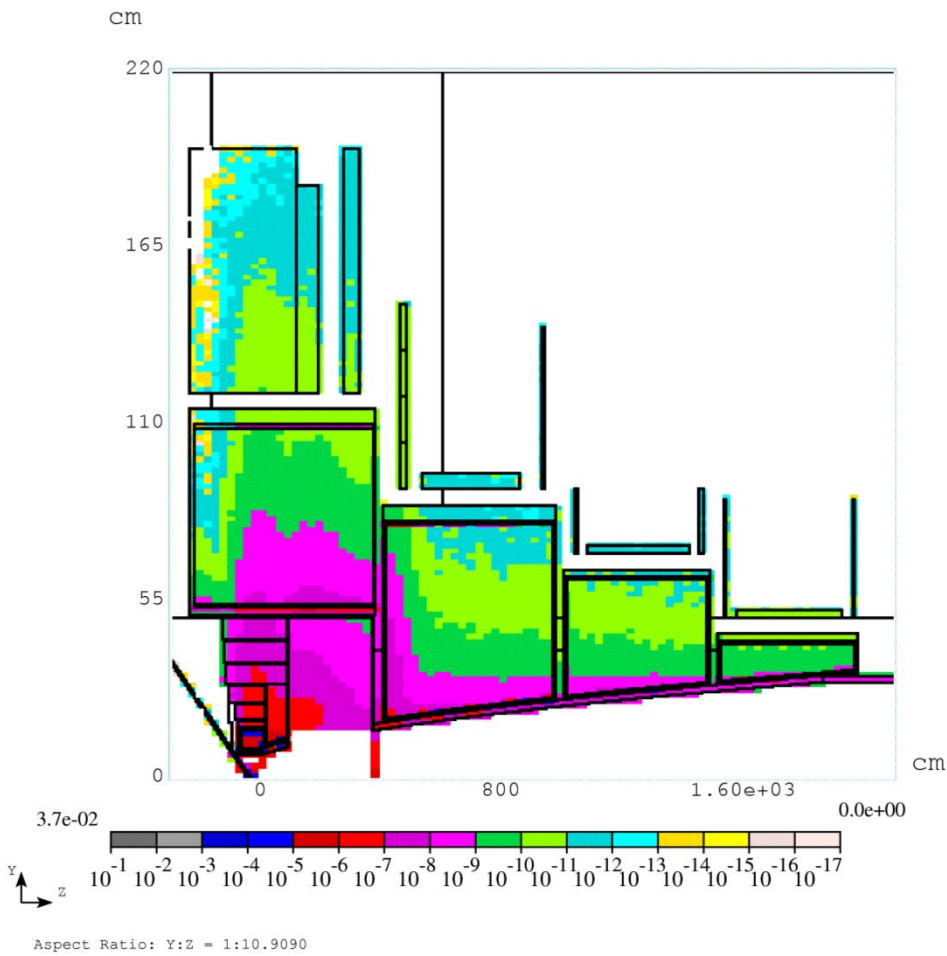

**FIRST LOOK: IT APPEARS THE RADIATION ENERGY IS NOW SPREAD OUT MORE AROUND THE TARGET REGION (COLORS CORRESPOND TO DIFFERENT SCALES THOUGH). IT IS NOT CLEAR IF THAT IS DUE TO THE WEAKER MAGNETIC AROUND THE TARGET REGION AND/OR BECAUSE STST IS FILLING UP THE REST OF THE VOLUME IN THE Hg VESSEL AND/OR STST IS REPLACING THE RS / SH1 .**

**IDS120j: SC#4 DPD AZIMUTHAL DISTRIBUTIONS FOR 20 cm GAPS WITH STST IN RS/SH1 UPPER HALF OF Hg POOL ( FORM 4 x 5E05 EVENTS, 15.8 g/cc W BEADS DENSITY )**

**IDS120j: SC#4 AZIMUTHAL DPD FOR 20 cm GAPS (AVERAGE FROM 4 x 5E05 RUN)**

**W DENSITY=15.8 g/cc (REPLACING RS/SH1 AND FILLING UPPER HALF OF Hg POOL VESSEL WITH STST)**

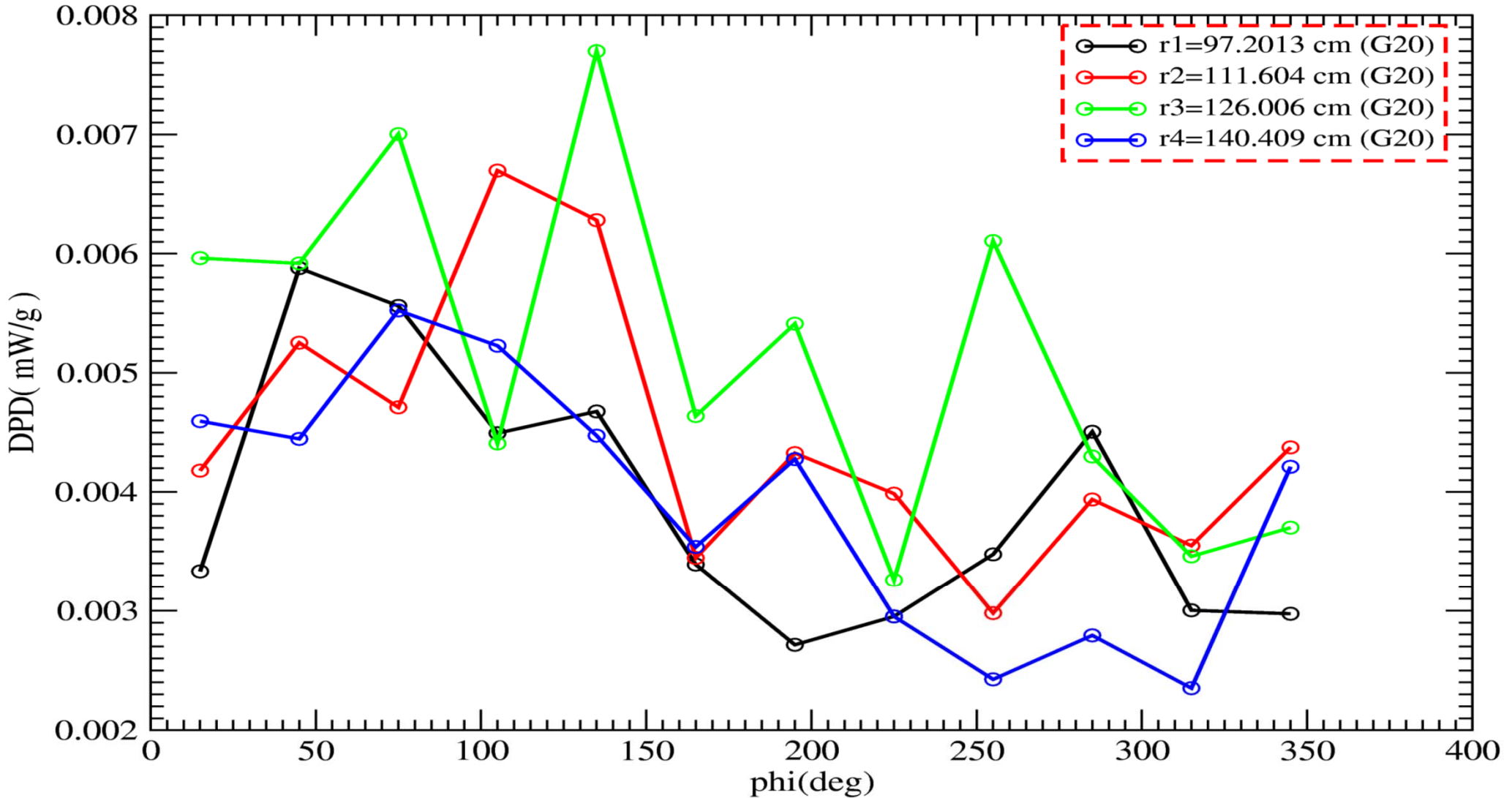

**PEAK POWER DENSITIES IN SC#4 ARE MUCH LOWER THAN 0.15 mW/g. THIS IS DUE MOSTLY TO THE STST IN THE UPPER HALF IN THE Hg POOL VESSEL (SOME WEAK UPWARDS PREFERENCE STILL CAN BE SEEN IN THE AZIMUTHAL DPD DISTRIBUTION) AND THE WEAKER MAGNETIC FIELD IN THE TARGET REGION**

# IDS120j : DEPOSITED POWER (kW) IN DIFFERENT COMPONENTS

(STST IN THE PLACE OF RS / SH1, FILLING UPPER HALF Hg POOL)

WITH RS, 20 cm GAPS

WITHOUT RS, 20 cm GAPS,

BeWind:	5.95	6.12	
Hg POOL:	435.56	421.05	
Hg JET:	400.40	396.75	
RS:	310.69	-----	
BP1:	223.35	-----	
BP2:	185.28	-----	
BP3:	4.99	16.85	
BP TOT:	413.62	16.85	--- BP#1, BP#2 ARE PART OF THE STST CYLINDER
SC#1:	0.658	0.740	--- ONLY A SMALL INCREASE
SC#2:	0.194	0.096	
SC#3:	0.114	0.019	
SC#4:	0.272	0.027	
SC#5-9	0.021	0.020	
SC#10-12	0.054	0.104	--- MORE DP IN DOWNSTREAM SCs
SC TOT:	1.313	1.01	--- TOTAL DP IN SC SLIGHTLY LESS
SH#1:	896.88	(2239.00)	--- IN STST VOLUME, MORE THAN ~ 56 % OF 4 MW
SH#1A:	330.29	(2239.00)	

THE RESULTS ARE FOR A SOLID STST VOLUME IN RS / SH1 / UPPER HALF OF Hg TUBE WITHOUT CONSIDERING COOLING OF THAT VOLUME.

**IDS120j: REPLACING RESISTIVE MAGNETS AND FILLING UPPER HALF OF Hg POOL WITH SHIELDING. GENERAL OVERVIEW (LEFT), POOL REGION DETAILS (RIGHT). [20 cm GAPS]**

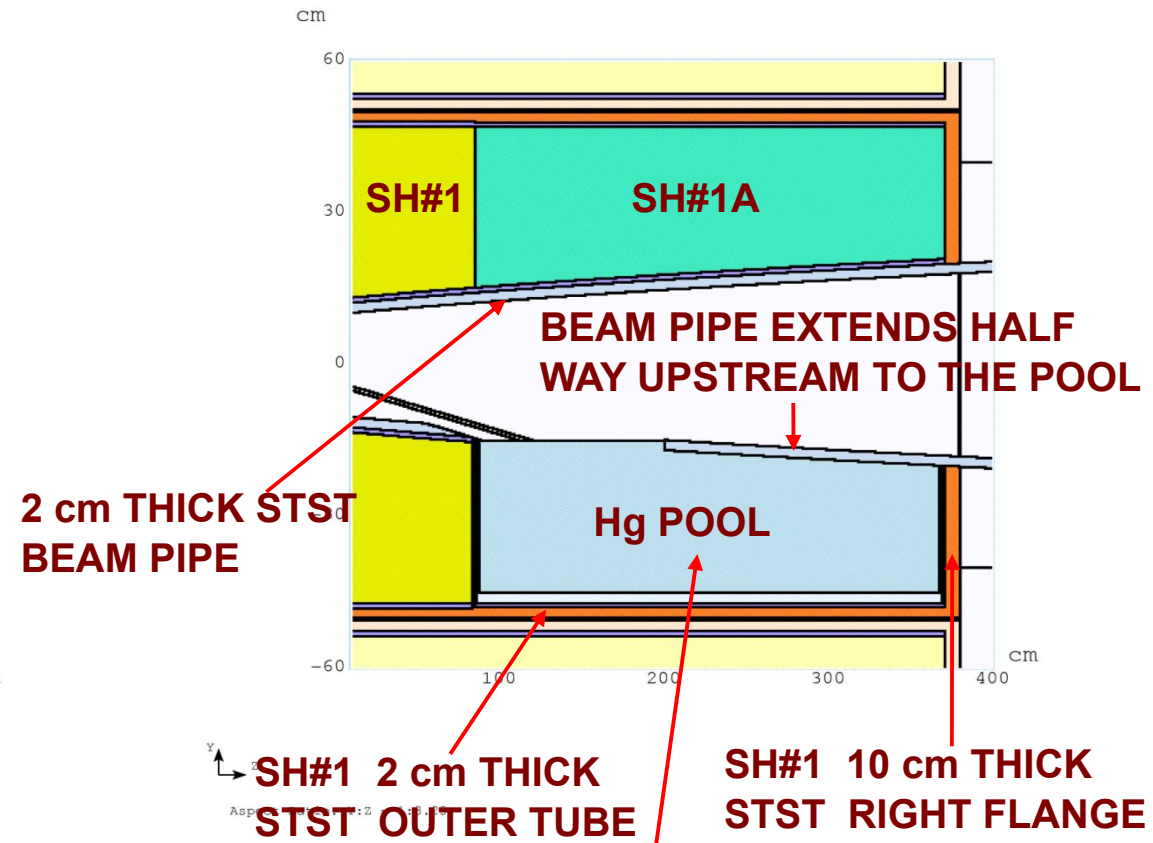
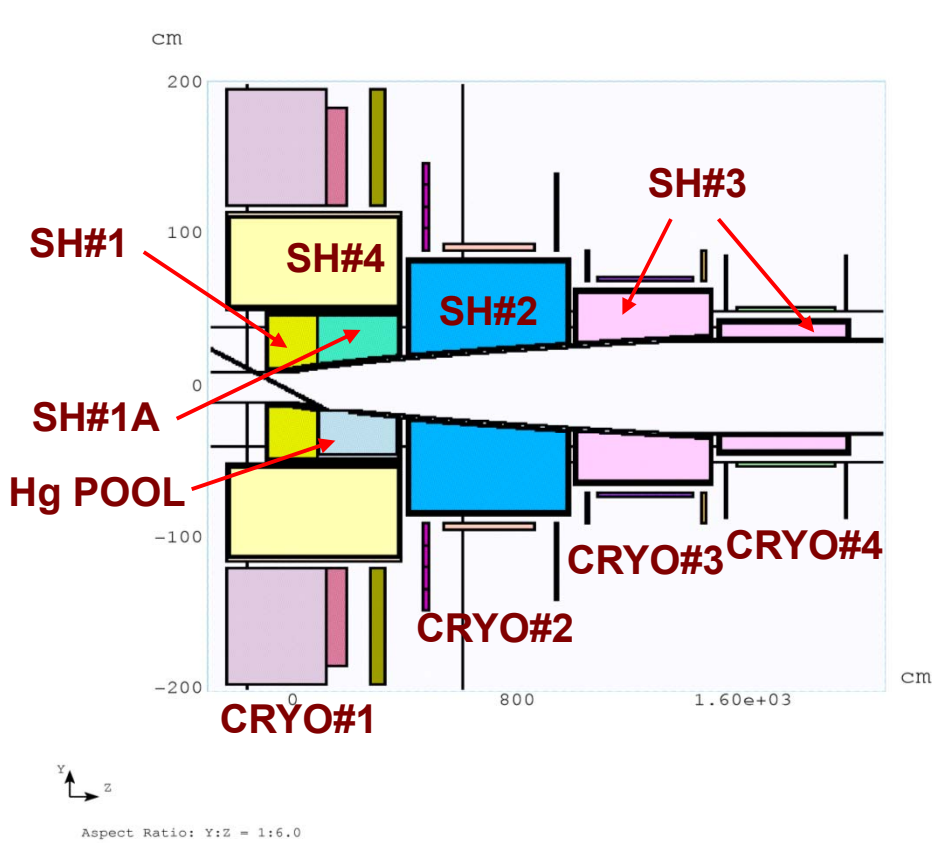

**Hg POOL STARTS ~ 85 cm AND EXTENDS ALL THE WAY TO THE END OF THE FIRST CRYOSTAT ~ 370 cm.**

**SHVS WALLS, Hg POOL VESSEL DOUBLE WALLS, Be WINDOW, He GAP IN Be WINDOW AND IN Hg POOL HAVE NOMINAL VALUES FOR THEIR THICKNESS. STRESS FORCES ANALYSIS AND LOCAL DPD DISTRIBUTION WILL BE USED TO DETERMINE THEIR VALUES.**



**IDS120j: WITHOUT RESISTIVE MAGNETS. DETAILS OF THE DOUBLE STST Hg POOL VESSEL (LEFT, MIDDLE) AND THE DOUBLE Be WINDOW (RIGHT). [20 cm GAPS]**

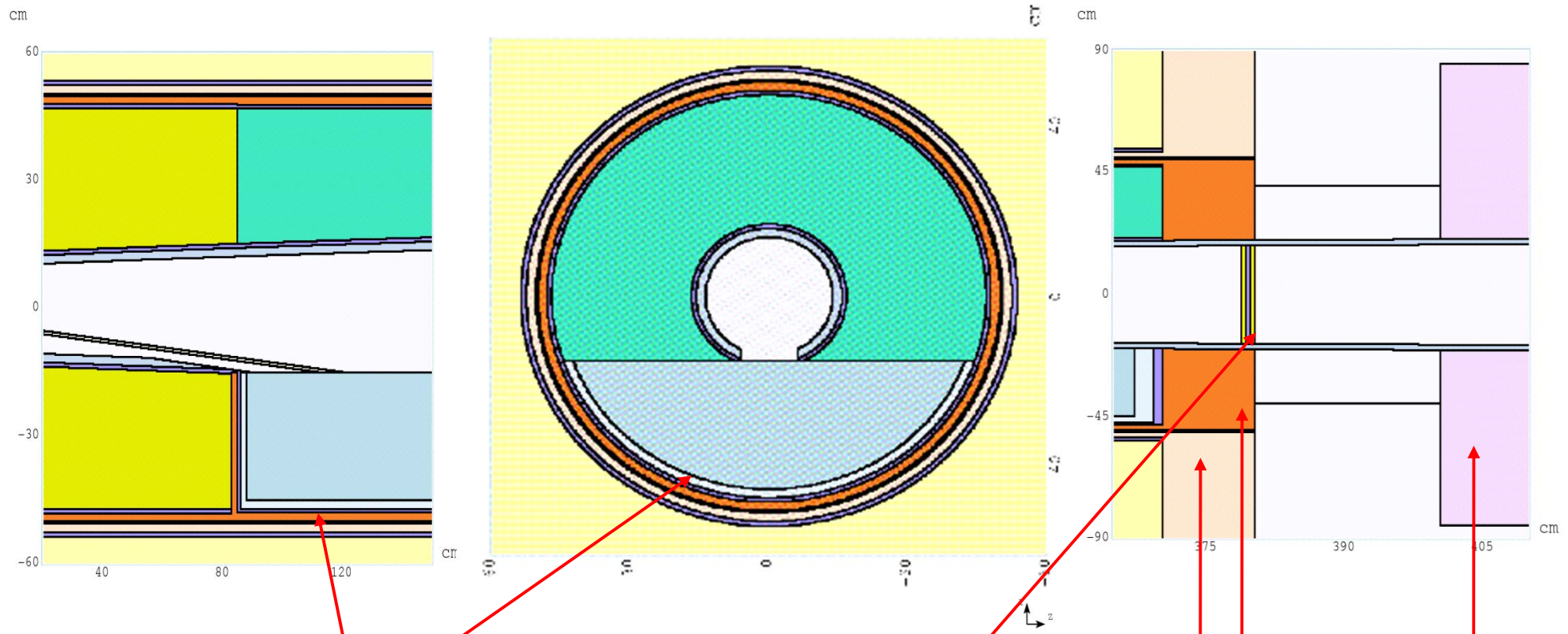

**2 cm THICK STST INNER Hg POOL VESSEL WITH 1 cm He GAP FOR COOLING.**

**TWO 0.5 cm THICK Be WINDOWS AT THE END OF CRYO#1 WITH 0.5 cm He GAP BETWEEN THEM FOR COOLING.**

**10 cm THICK STST RIGHT / LEFT FLANGE OF SHVS#4, SHVS#1 / SHVS#2 WITH 20 cm GAP BETWEEN THEM.**



**IDS120j: AZIMUTHALLY AVERAGE DPD MARS PLOTS, FOR 15.8 g/cc W BEADS, WITH (LEFT) AND WITHOUT (RIGHT) RESISTIVE MAGNETS FOR 20 cm GAPS. P12 INITIAL PROTON BEAM POINT WAS USED FOR THE LAST CASE SIMULATIONS.**

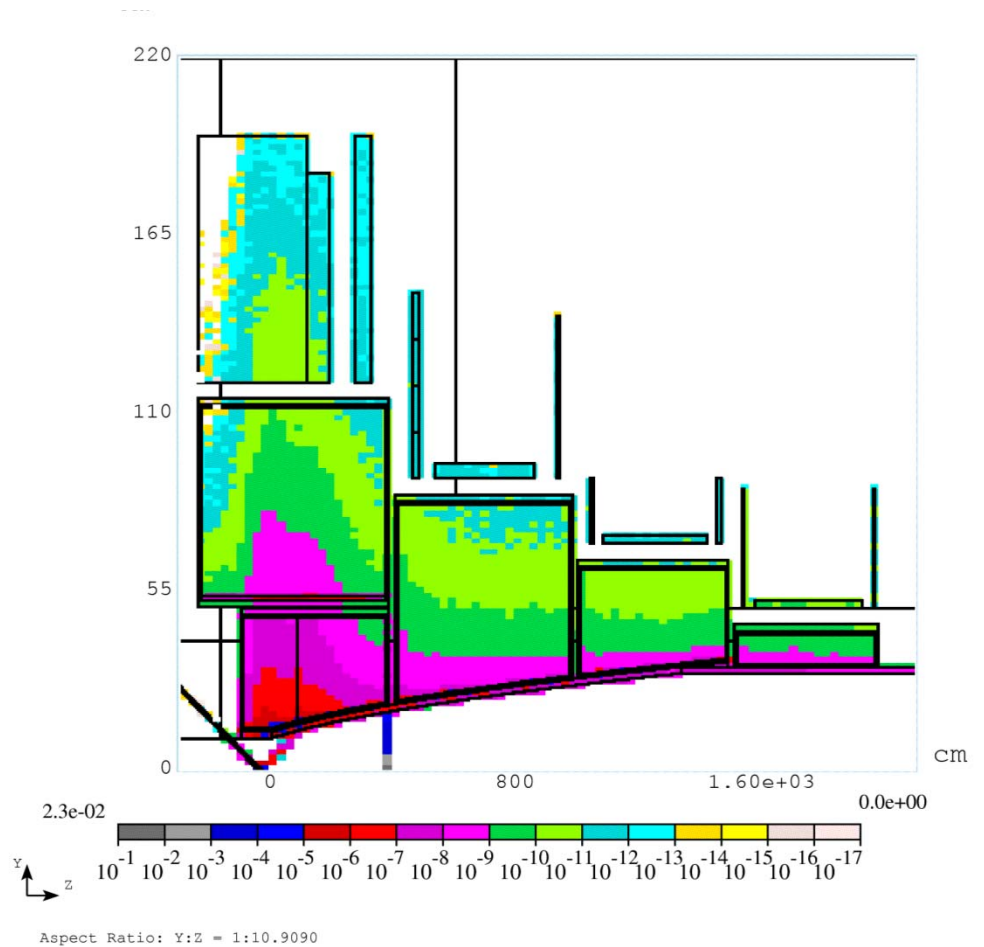
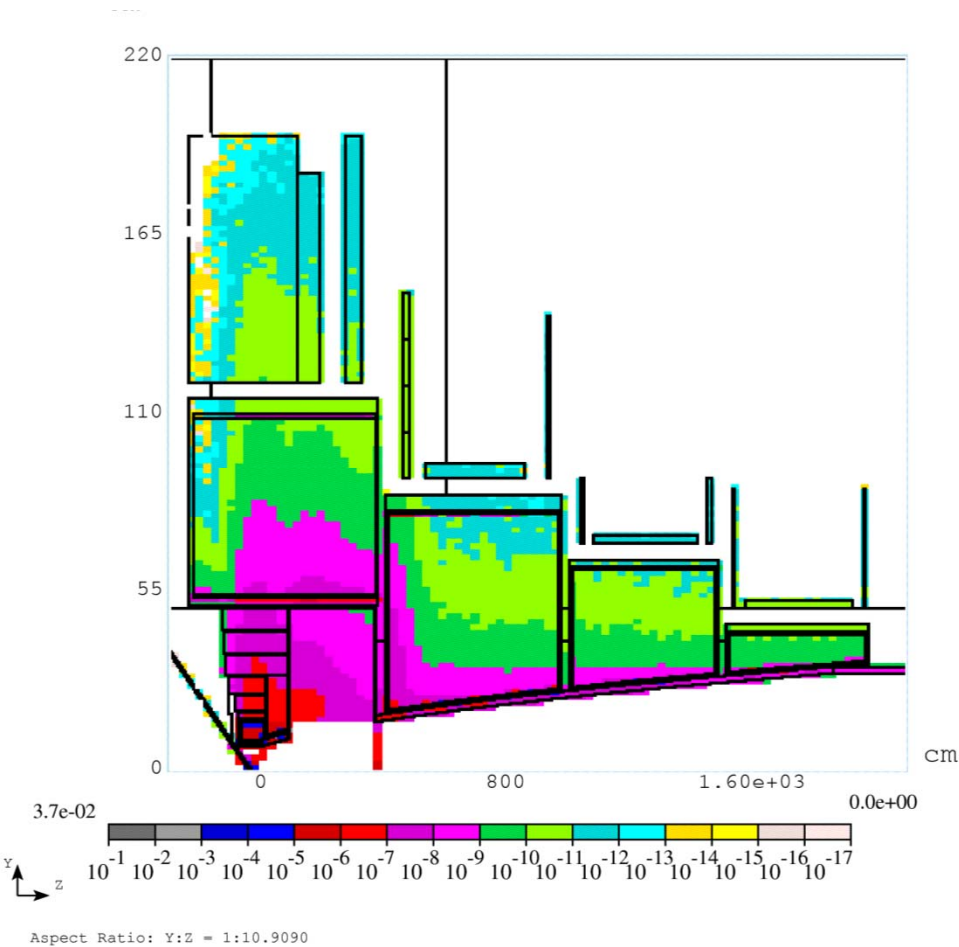

**FIRST LOOK: AS A RESULT OF THE THE SHIELDING IN THE UPPER HALF OF THE Hg POOL IT APPEARS RADIATION ENERGY IS NOT SPREAD OUT SO MUCH DOWNSTREAM. ON THE OTHER HAND, SURPRISINGLY, REPLACING THE RESISTIVE COILS WITH SHIELDING IT APPEARS DOES NOT CHANGE SO MUCH THE RADIAL SPREADING AROUND THE TARGET REGION. THIS IN PART MAYBE RELATED TO THE DIFFERENT INITIAL BEAM POINTS USED FOR THE TWO CASES AND/OR THE LARGER APPERTURE (7.5 --> 10.0 cm) IN THE TARGET REGION.**

**IDS120j: NO RESISTIVE COILS. GAP BETWEEN CRYO 1-2 AND SC#4 SEGMENTATION DETAILS.**

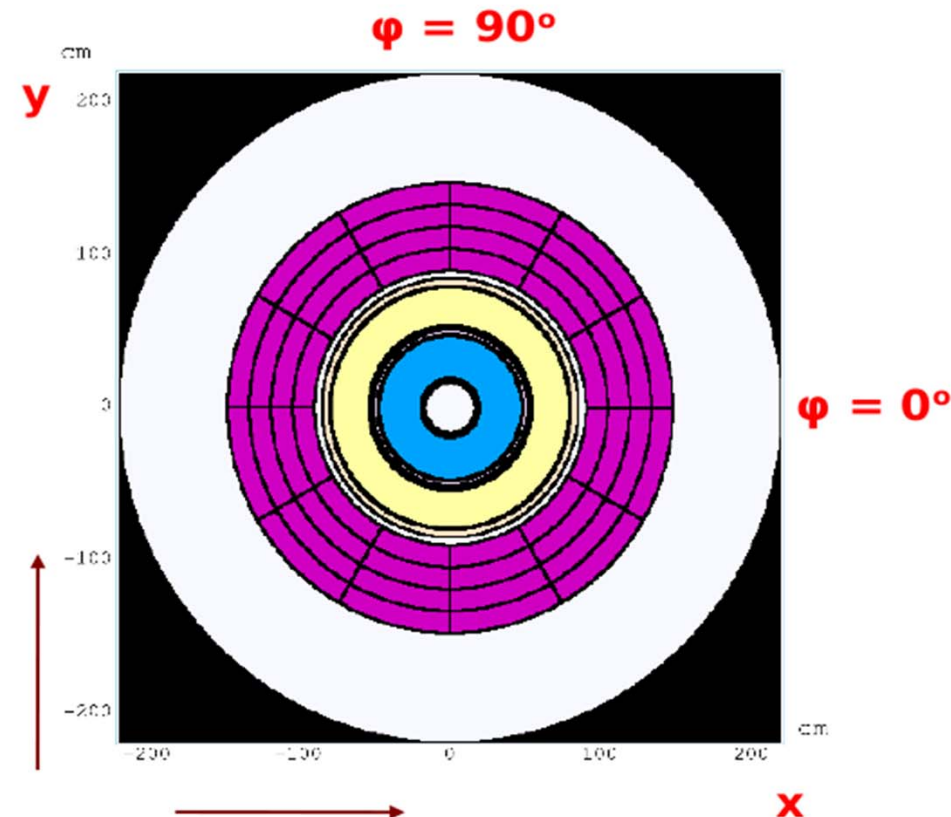
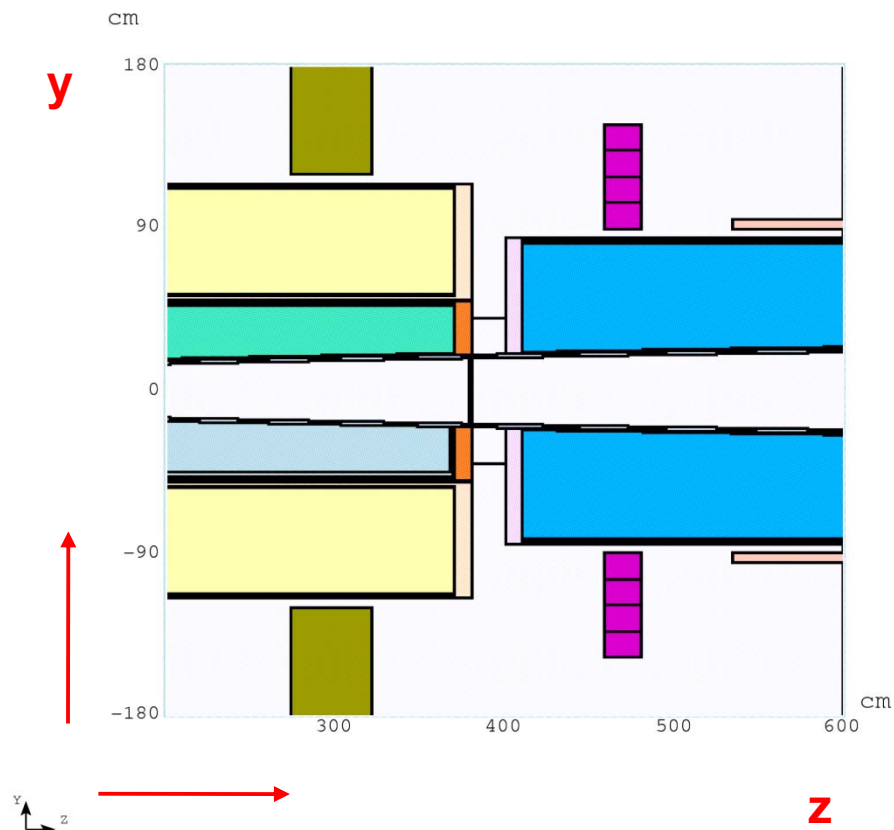

Aspect Ratio: Y:Z = 1:1.11111  
 Aspect Ratio: X:Z = 1:1.11111

Aspect Ratio: X:Y = 1:1.0

$90 < r < 147.61 \text{ cm}$   
 $459.0 < z < 480.31 \text{ cm}$   
 $0.0 < \phi < 360.0 \text{ deg.}$

$dr = 14.40 \text{ cm}$       $N_r = 4 \text{ bins}$   
 $dz = 21.31 \text{ cm}$       $N_z = 1 \text{ bin}$   
 $d\phi = 30 \text{ deg.}$       $N_\phi = 12 \text{ bins}$

$N_{\text{tot}} = 48 \text{ "pieces"}$

**IDS120j: SC#4 DPD AZIMUTHAL DISTRIBUTIONS FOR 20 cm GAPS  
( FORM 4 x 5E05 EVENTS, 15.8 g/cc W BEADS DENSITY )**

**IDS120j: SC#4 AZIMUTHAL DPD FOR 20 cm GAPS (AVERAGE FROM 4 x 5E05 RUN)**

W DENSITY=15.8 g/cc

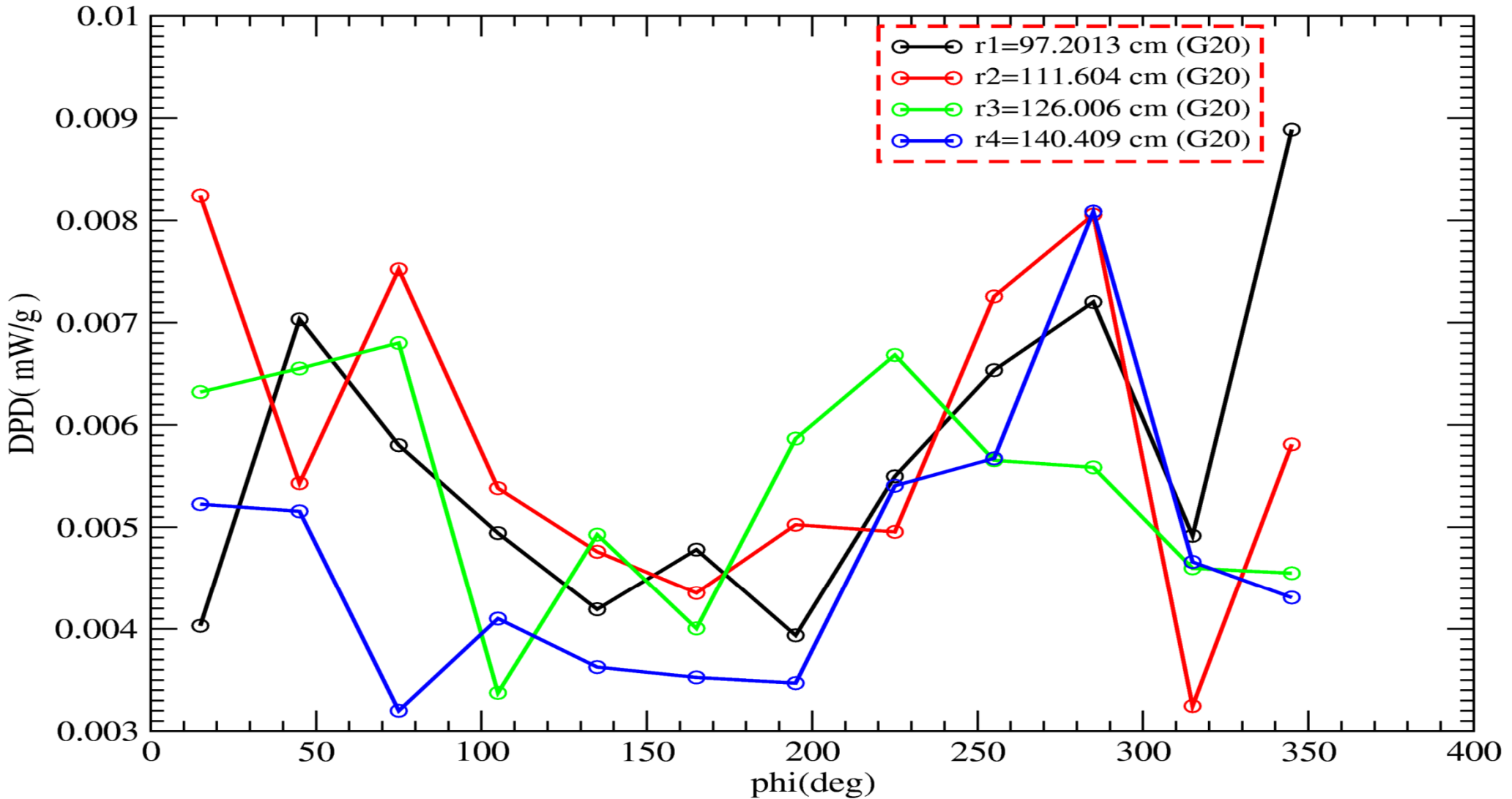

**AS WAS EXPECTED 20 cm OR LARGER GAPS IN THE SHIELDING FOR THE CRYOSTATS #1 AND #2 APPEAR TO PRESENT NO PROBLEM FOR THE PEAK DPD IN SC#4, IT IS MUCH LOWER THAN THE ITER LIMIT. PEAK VALUES FOR P12 APPEAR IN THE LOWER HALF OF THE COIL (DUE TO Hg POOL)**

## IDS120j : DEPOSITED POWER (kW) IN DIFFERENT COMPONENTS

WITH RS, 20 cm GAPS

WITHOUT RS, 20 cm GAPS, P12

BeWind:	5.95	7.57	
Hg POOL:	435.56	443.89	
Hg JET:	400.40	396.40	
RS:	310.69	-----	
BP1:	223.35	322.49	
BP2:	185.28	384.06	
BP3:	4.99	17.79	
BP TOT:	413.62	724.34	--- MORE DP IN BPs
SC#1:	0.658	0.470	--- ONLY A SMALL DECREASE
SC#2:	0.194	0.092	
SC#3:	0.114	0.022	
SC#4:	0.272	0.033	
SC#5-9	0.021	0.031	
SC#10-12	0.054	0.144	--- MORE DP IN DOWNSTREAM SCs
SC TOT:	1.313	0.792	--- TOTAL DP IN SC < 1 kW
SH#1:	896.88	1256.00	--- MORE THAN ~ 30 % OF 4 MW
SH#1A:	330.29	179.60	
SH#2:	92.99	29.52	
SH#3:	8.36	12.65	
SH#4 :	115.15	41.43	
SH TOT:	1443.67	1519.20	
SHVS#1:	182.38	10.66	--- DIFFERENT CONFIGURATION
SHVS#2:	71.28	2.84	--- DIFFERENT CONFIGURATION
SHVS#3:	0.72	1.47	
SHVS#4:	26.13	4.28	
SHVS TOT:	280.50	19.25	
Hg POOL WALL:	15.36	6.45 (INNER WALL)	
TOTAL:	3307.06	3118.95	