

IDS120j WITHOUT RESISTIVE MAGNETS

**SEMMENTATION STUDIES FOR BEAM PIPE BEYOND FIRST CRYOSTAT
(20 cm GAPS AND 15.8 g/cc W BEADS)**

Nicholas Souchlas, PBL (7/25/2012)

IDS120j GEOMETRY, NO RESISTIVE COILS: WITH 20 cm GAPS

SIMULATIONS USING LOWEST GRADE W BEADS IN SHIELDING (OF 15.8 g/cc)

BP SEGMENTATION STUDIES AFTER THE FIRST CRYOSTAT (CRYO#2/3/4).

>SIMULATIONS CODE: mars1512 (USING MCNP CROSS SECTION LIBRARIES)

>NEUTRON ENERGY CUTOFF: 10^{-11} MeV

>SHIELDING: 60% W + 40% He (WITH STST VESSELS)

>PROTON BEAM POWER: 4 MW

>PROTON ENERGY: E = 8 GeV

>PROTON BEAM PROFILE: GAUSSIAN, $\sigma_x = \sigma_y = 0.12$ cm

>EVENTS IN SIMULATIONS : $N_p = 500,000$

IDS120j: REPLACING RESISTIVE MAGNETS AND FILLING UPPER HALF OF Hg POOL WITH SHIELDING. GENERAL OVERVIEW (LEFT), POOL REGION DETAILS (RIGHT). [20 cm GAPS]

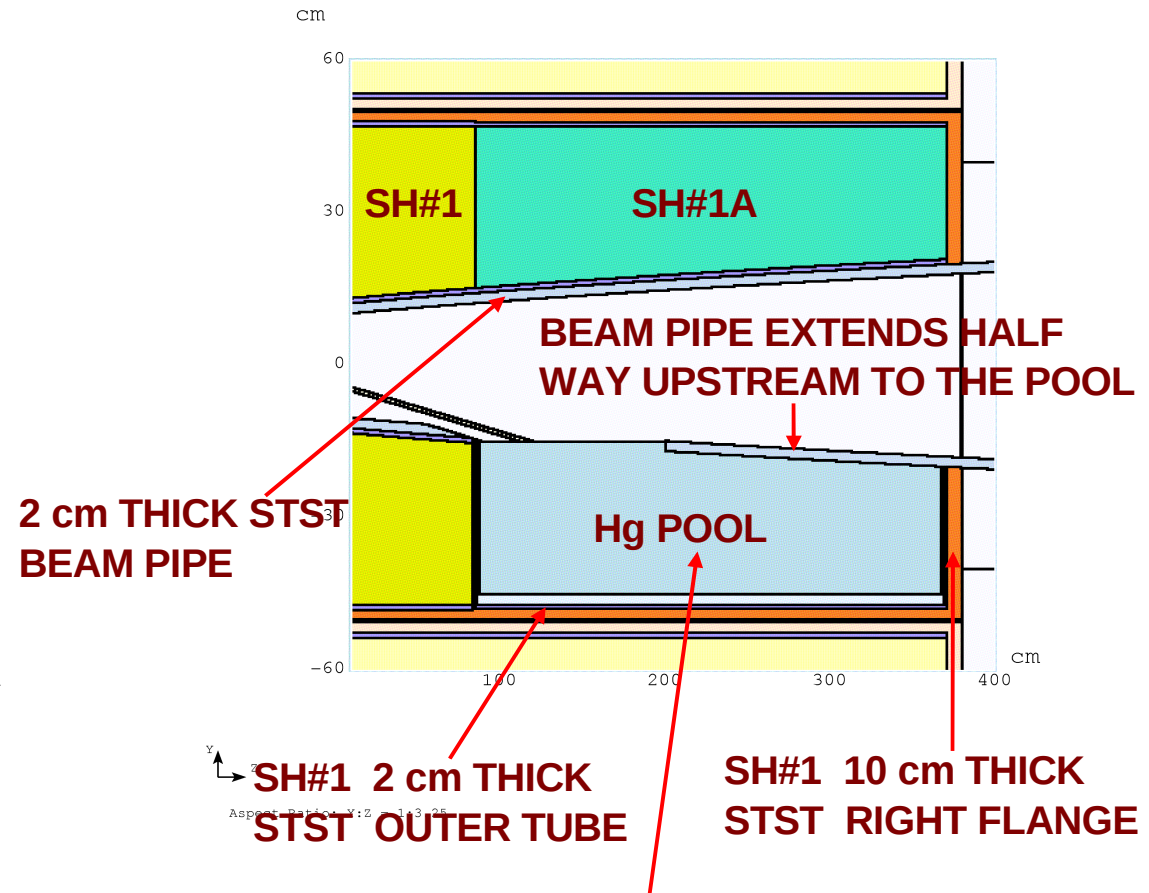
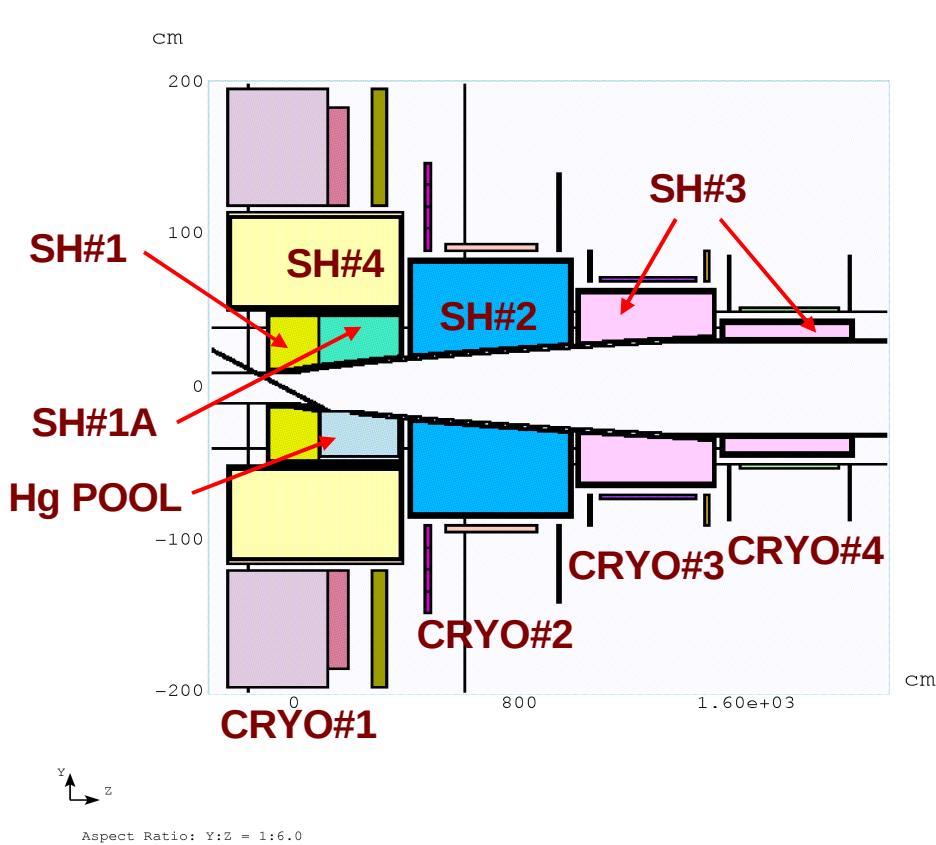

Hg POOL STARTS ~ 85 cm AND EXTENDS ALL THE WAY TO THE END OF THE FIRST CRYOSTAT ~ 370 cm.

SHVS WALLS, Hg POOL VESSEL DOUBLE WALLS, Be WINDOW, He GAP IN Be WINDOW AND IN HG POOL HAVE NOMINAL VALUES FOR THEIR THICKNESS. STRESS FORCES ANALYSIS, LOCAL DPD DISTRIBUTION AND ENGINEERING CONSIDERATIONS WILL DETERMINE THEIR VALUES.

IDS120j: WITHOUT RESISTIVE MAGNETS. DETAILS OF THE DOUBLE STST Hg POOL VESSEL (LEFT, MIDDLE) AND THE DOUBLE Be WINDOW (RIGHT). [20 cm GAPS]

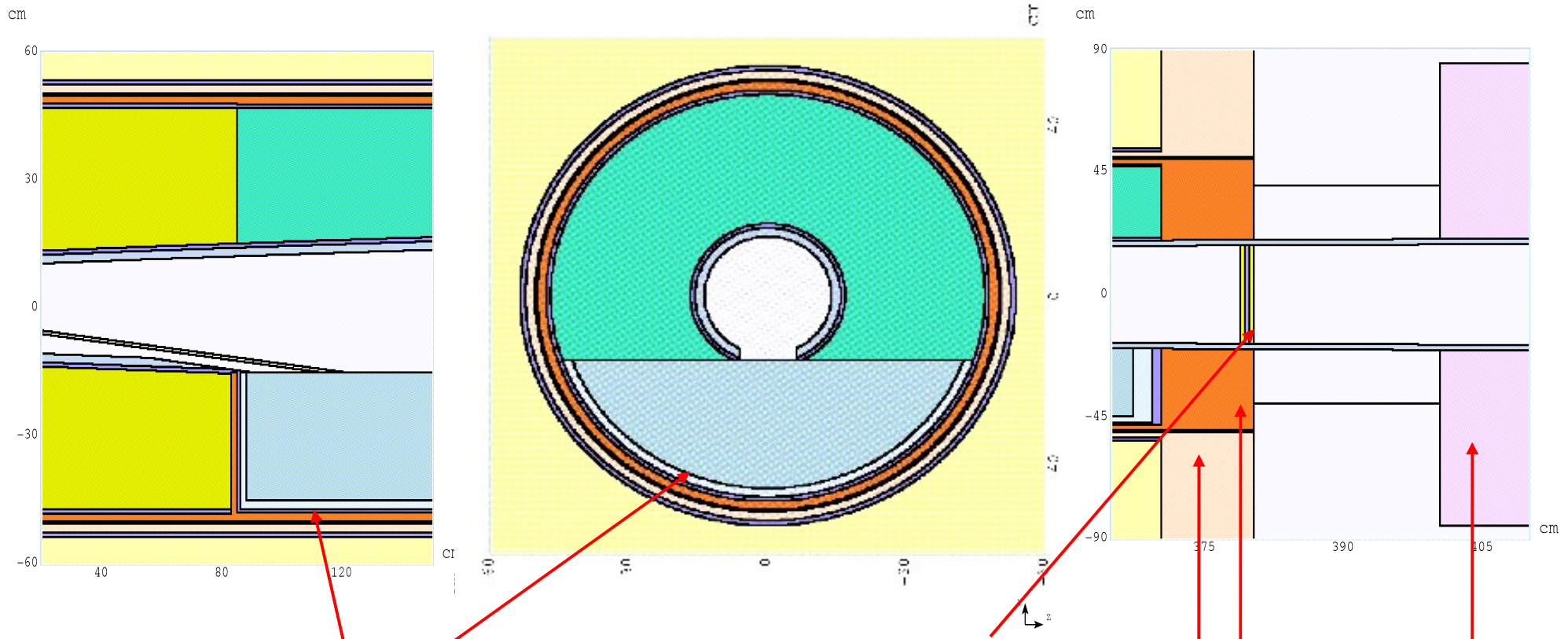

2 cm THICK STST INNER Hg POOL VESSEL WITH 1 cm He GAP FOR COOLING.

TWO 0.5 cm THICK Be WINDOWS AT THE END OF CRYO#1 WITH 0.5 cm He GAP BETWEEN THEM FOR COOLING.

10 cm THICK STST RIGHT / LEFT FLANGE OF SHVS#4, SHVS#1 / SHVS#2 WITH 20 cm GAP BETWEEN THEM.

**IDS120j: DETAILS OF THE DOUBLE WALL Hg POOL VESSEL ENVISIONED BY VAN GRAVE.
(PLOTS ARE FROM VAN GRAVE'S 6/12/2012 PRESENTATION)**

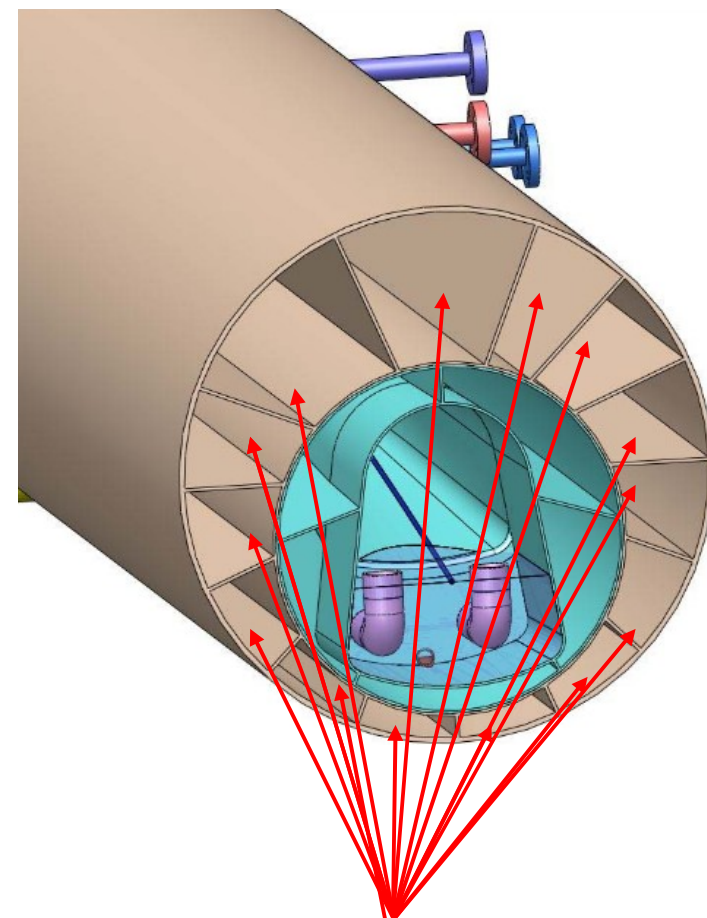
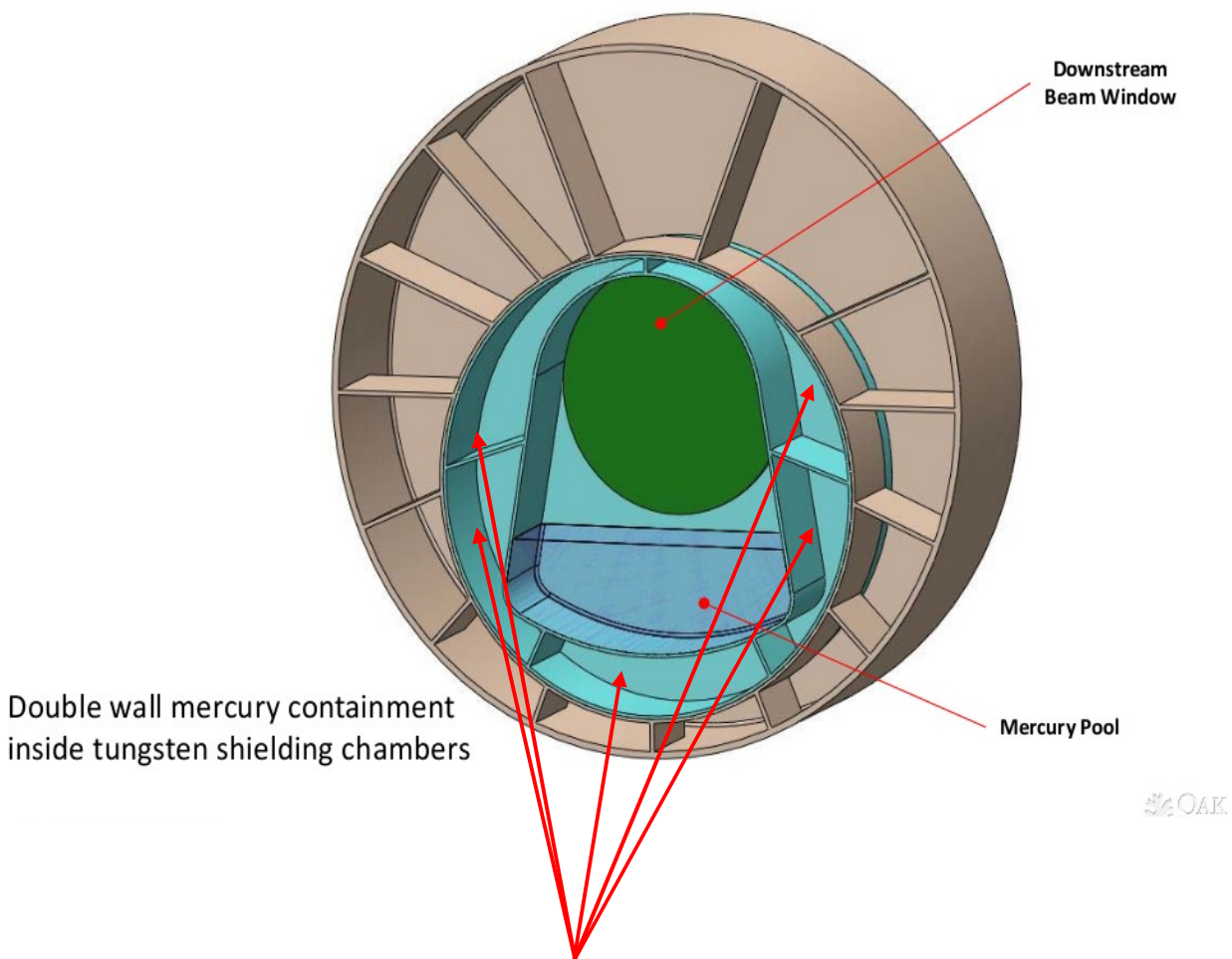

He GAS WILL BE FLOWING BETWEEN THE TWO WALLS FOR COOLING. THE BEAM PIPE IN THAT AREA WILL BE PART OF THE POOL VESSEL AND REMOVING THE HEAT LOAD WILL BE A CHALLENGING TASK. SEGMENTATION ANALYSIS WILL BE PERFORMED TO DETERMINE THE AZIMUTHAL DPD DISTRIBUTION.

IDS120j: yz CROSS SECTION WITH DETAILS OF THE BP#2 SEGMENTATION IN CRYO#2 REGION

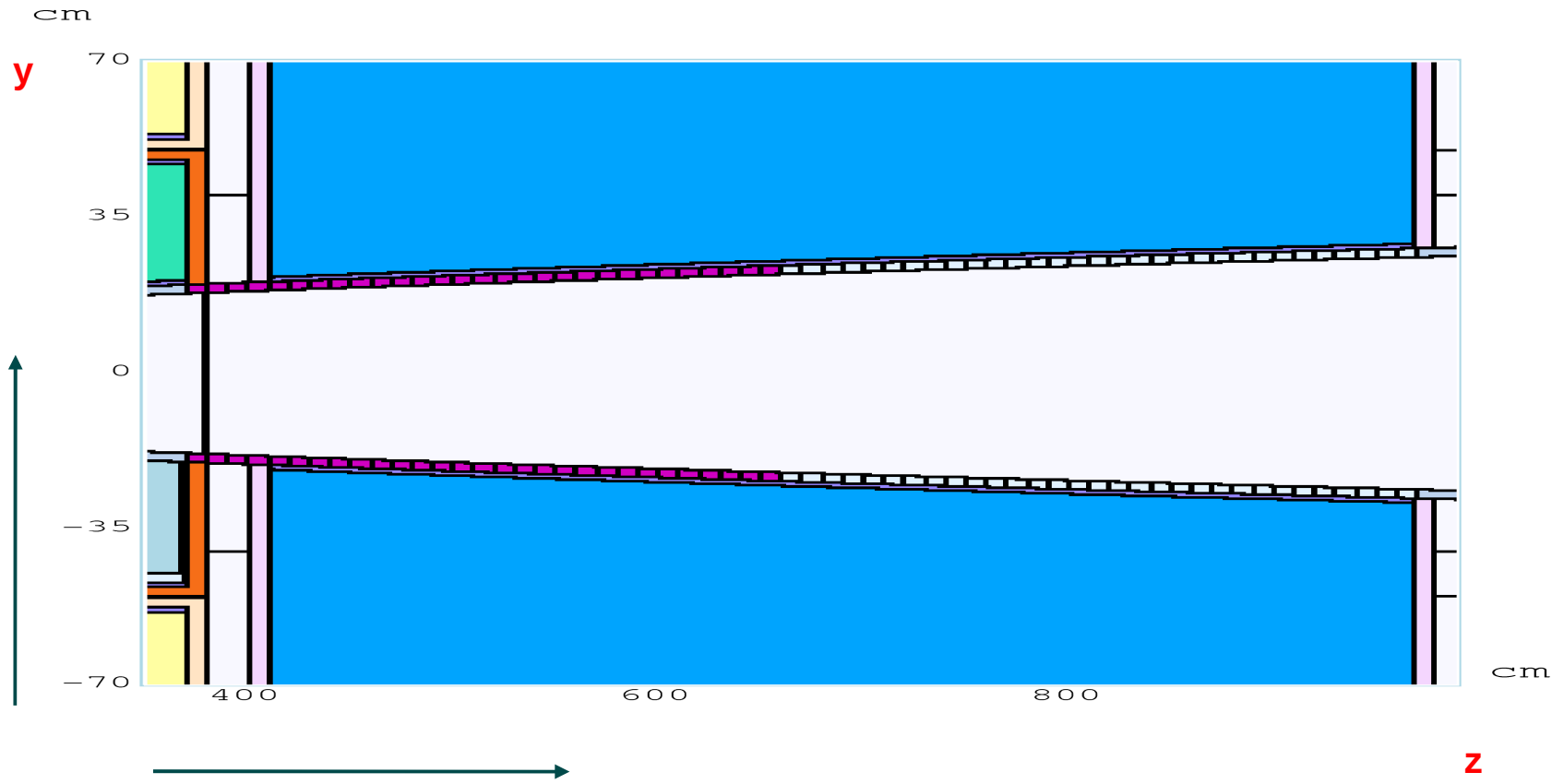

Aspect Ratio: Y:Z = 1:4.57142

$Rap(z) < r < Rap(z) + dr$ cm	$dr = 2.00$ cm	$N_r = 1$ bins
$370.0 < z < 970.0$ cm	$dz = 10.00$ cm	$N_z = 60$ bins
$0.0 < \phi < 360.0$ deg.	$d\phi = 30$ deg.	$N_\phi = 12$ bins
$N_{tot} = 720$ "pieces"		

Volumes calculated using a closed form expression.

IDS120j: yz AND xy CROSS SECTIONS WITH DETAILS OF THE BP#2 SEGMENTATION

$x = 0.0$

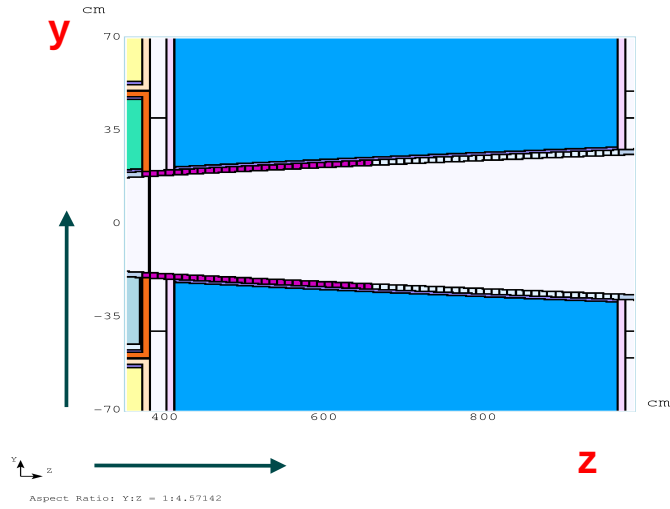

$z = 371.0$

$\phi = 90^\circ$

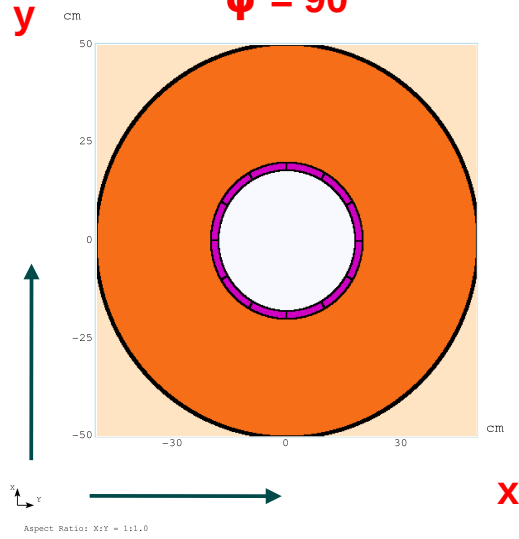

$z = 400.0$

$\phi = 0^\circ$

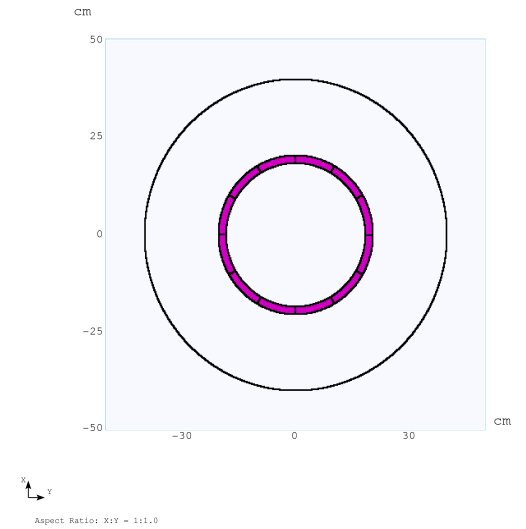

$z = 600.0$

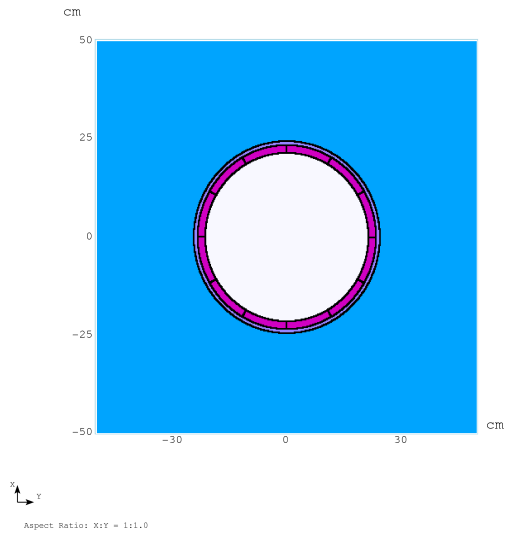

$z = 800.0$

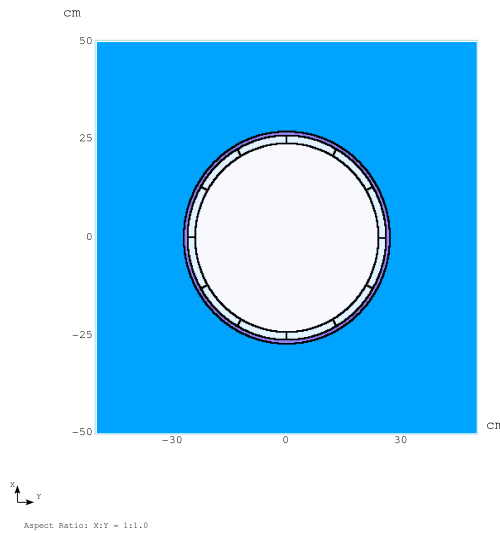

$z = 900.0$

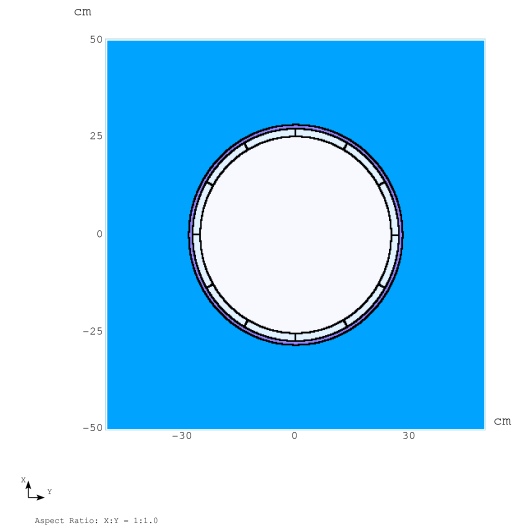

DP vs. z for BP#2 from 370 < z < 970 cm (CRYO#2), for 12 angles

Coordinates are for the center of each piece, BP is 2.0 cm thick STST (dz= 10.0 cm, dr=2.0 cm, dphi = 30 deg.)

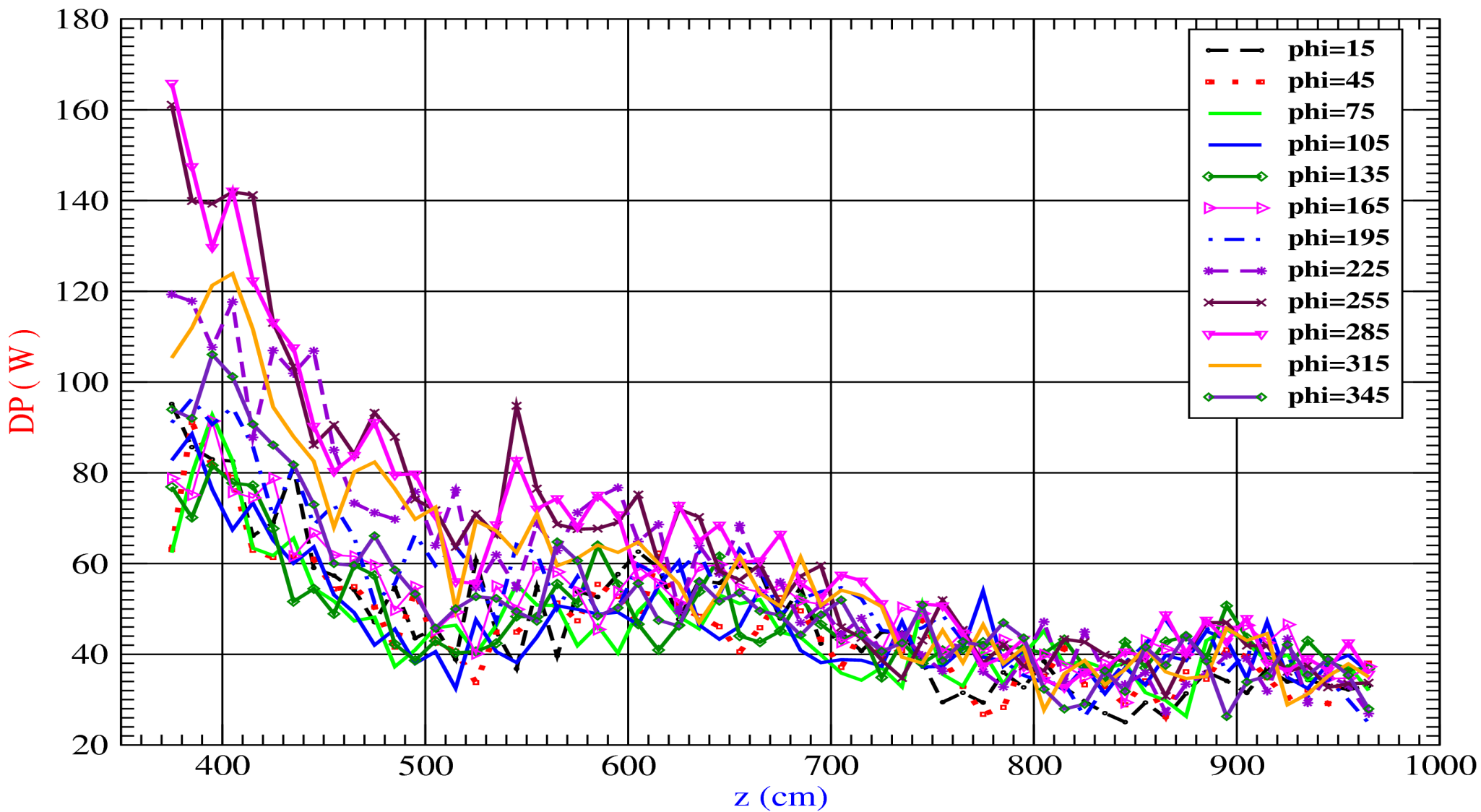

1 2 3 4 5 6 7 8 9 10 11 12

DP vs. z for BP#2 from $370 < z < 970$ cm (CRYO#2), for 2 angles

Coordinates are for the center of each piece, BP is 2.0 cm thick STST (dz= 10.0 cm, dr=2.0 cm, dphi = 30 deg.)

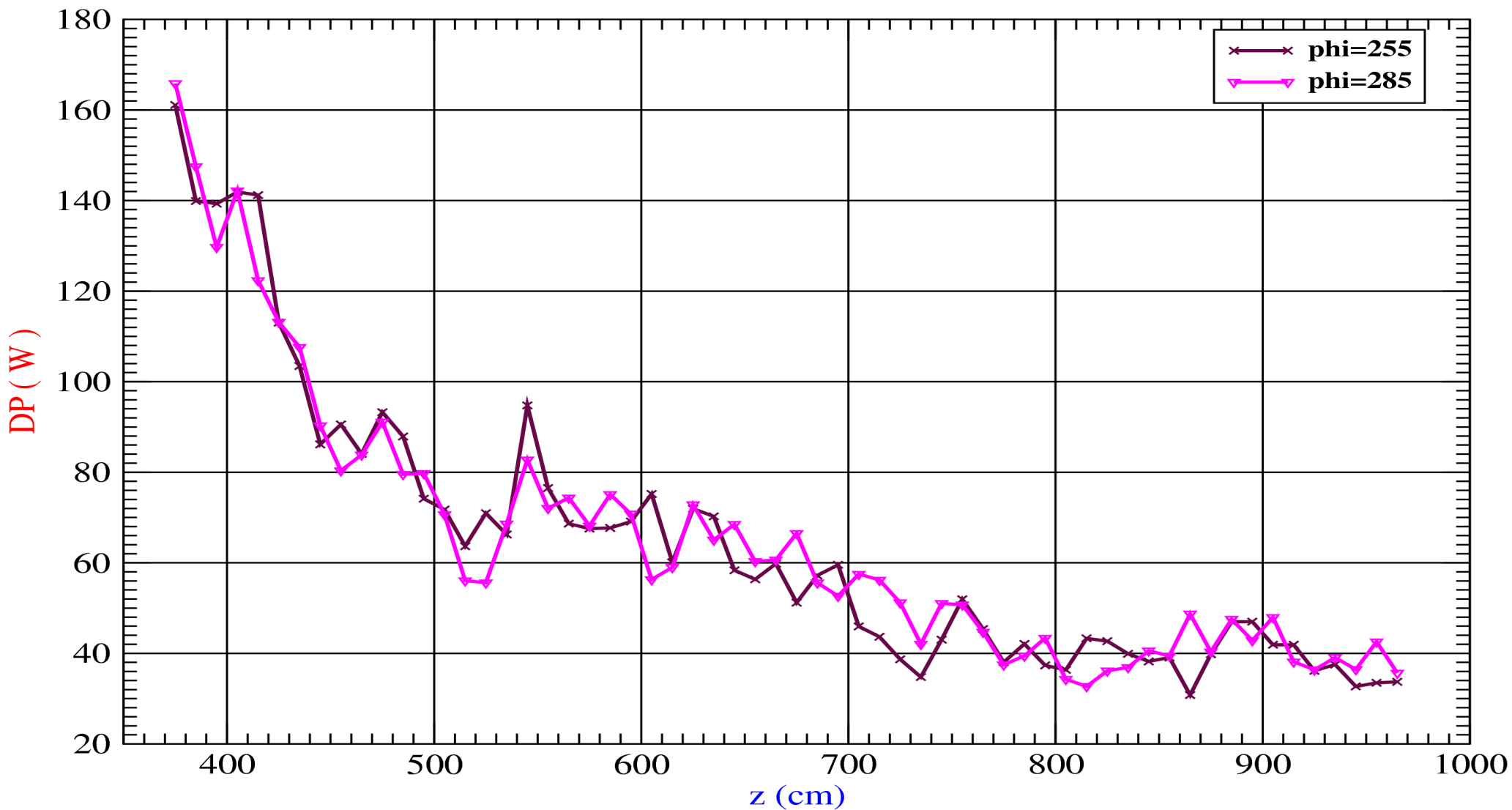

DPD vs. z for BP#2 from $370 < z < 970$ cm (CRYO#2), for 12 angles

Coordinates are for the center of each piece, BP is 2.0 cm thick STST (dz= 10.0 cm, dr=2.0 cm, dphi = 30 deg.)

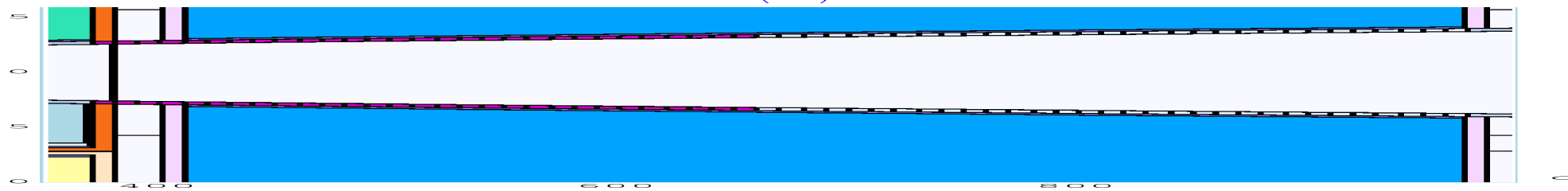
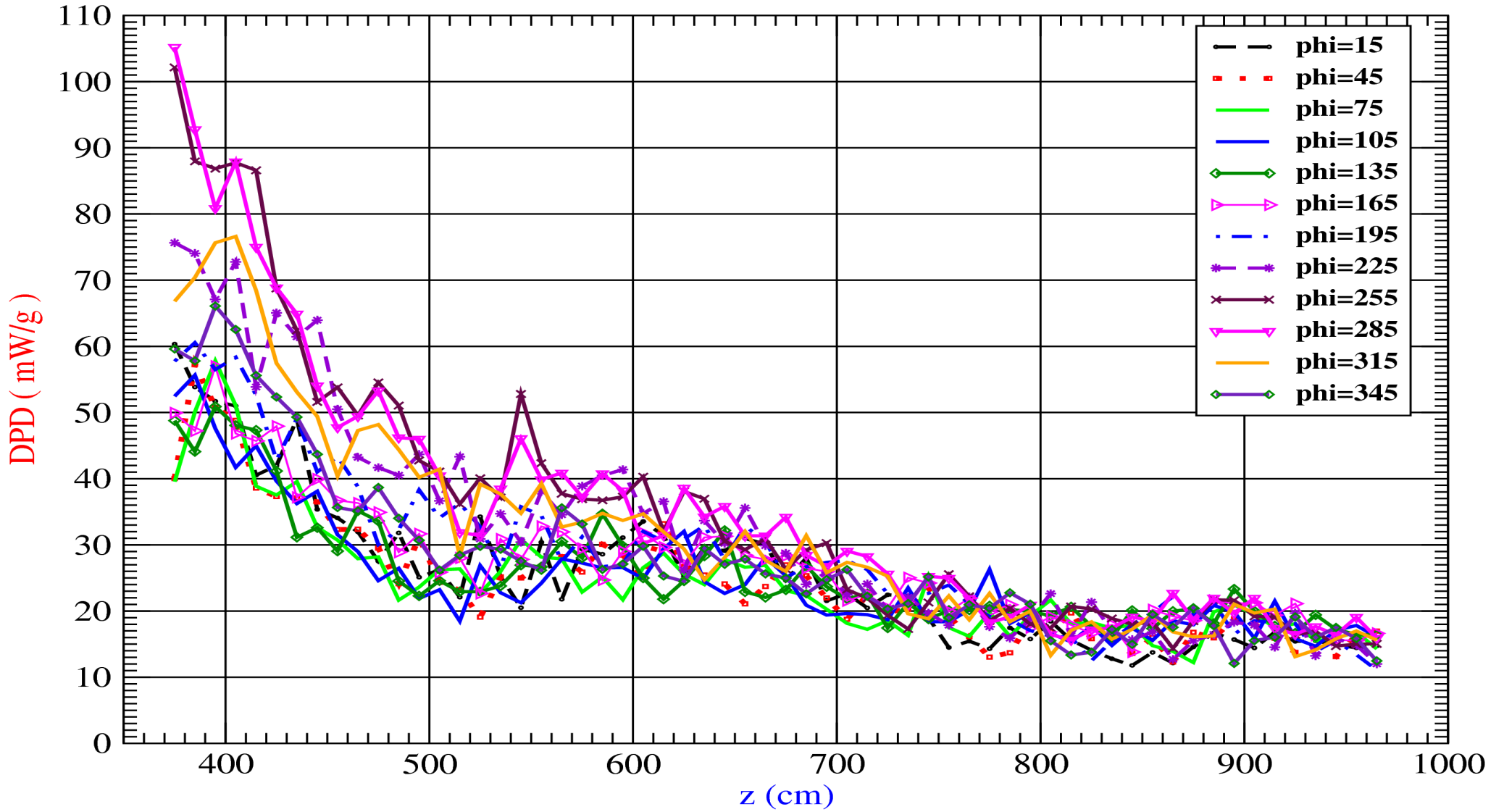

11-11-2011 11:41:57.142

DPD vs. z for BP#2 from 370 < z < 970 cm (CRYO#2), for 2 angles

Coordinates are for the center of each piece, BP is 2.0 cm thick STST (dz= 10.0 cm, dr=2.0 cm, dphi = 30 deg.)

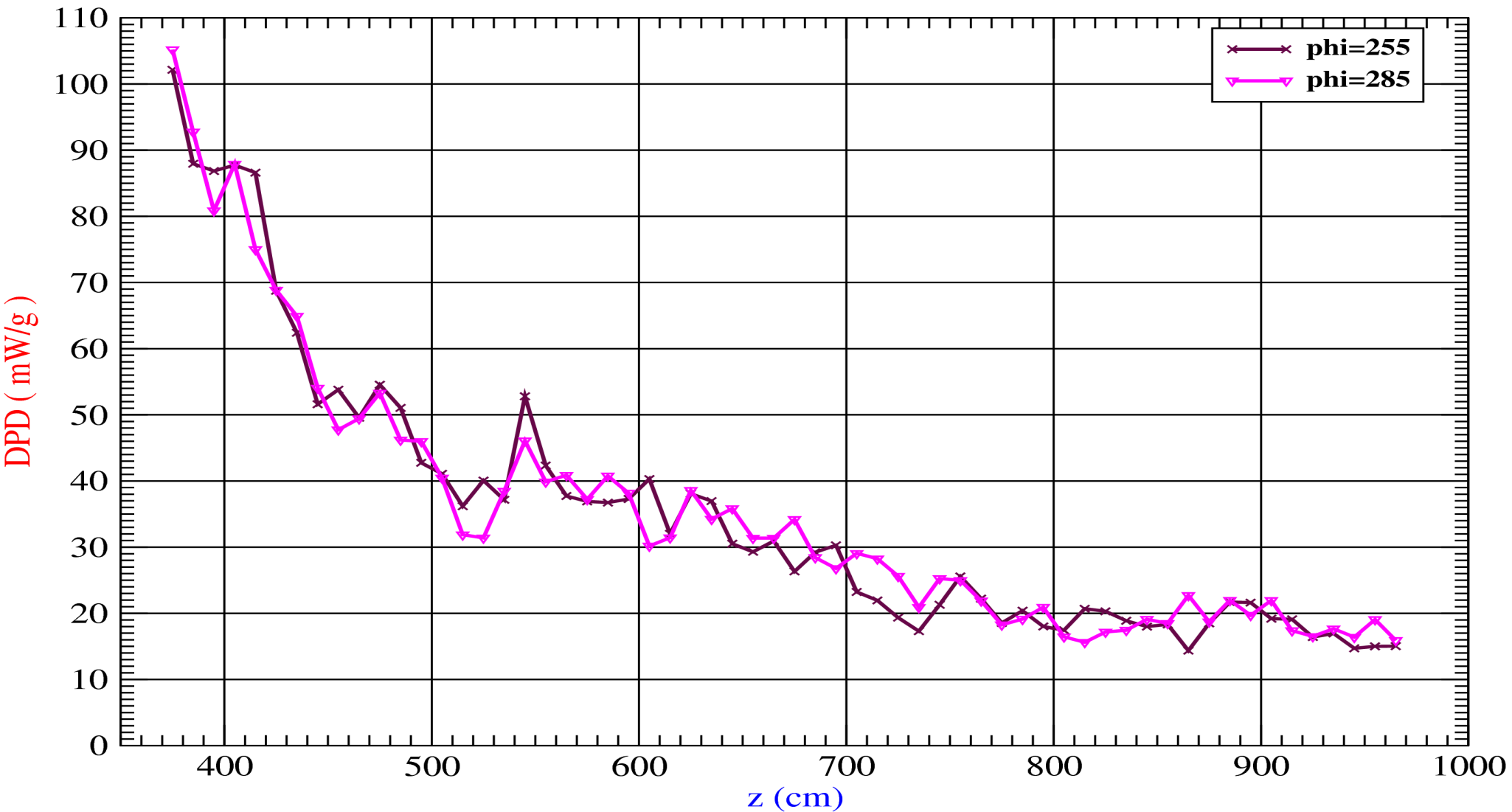

SUM OF DP FROM 720 PIECES :	38.02 kW
DP FROM REST OF BP#2 :	346.55 kW
TOTAL DP IN BP#2 :	384.57 kW
BP#2 DP WITHOUT SEGMENTATION:	384.06 kW

~ 38 kW IS DEPOSITED IN BP#2 PART WITHIN THE SECOND CRYOSTAT WITH ~ 6 m LENGTH.

LOWEST DPs (DPDs) ARE EXPECTED ALONG THE - x DIRECTION WHILE MOST OF THE DP IS BETWEEN 255 AND 315 DEGREES (- y DIRECTION). AS WE MOVE FURTHER DOWNSTREAM THE ASSYMETRY IN THE DP (DPD) AZIMUTHAL DISTRIBUTION DECREASES.

IT APPEARS THERE IS NO SMOOTH DECREASE OF THE DP (DPD) WITH z. ONE CAN SEE FOR EXAMPLE FROM THE 255 AND 285 DEGREES DISTRIBUTIONS THERE IS FAST DECREASE FROM ~ 380.0 cm TO ~ 520.0 cm AND THEN THERE IS A SPIKE AT ~ 550.0 cm.

MAXIMUM DPD IS ~ 95 mW/g NEAR THE BEGINNING OF THE PIPE (WITHIN CRYO#2 REGION) IN THE LOWER HALF OF THE PIPE, AS ONE MAY EXPECT.

A PERIODIC FUNCTION WITH AN EXPONENTIAL DECAYING AMPLITUDE MAYBE IS A GOOD FIT FOR THE AZIMUTHALLY AVERAGE DP (DPD) AS A FUNCTION OF z.

IDS120j: yz CROSS SECTION WITH DETAILS OF THE BP#2 SEGMENTATION IN CRYO#3 REGION

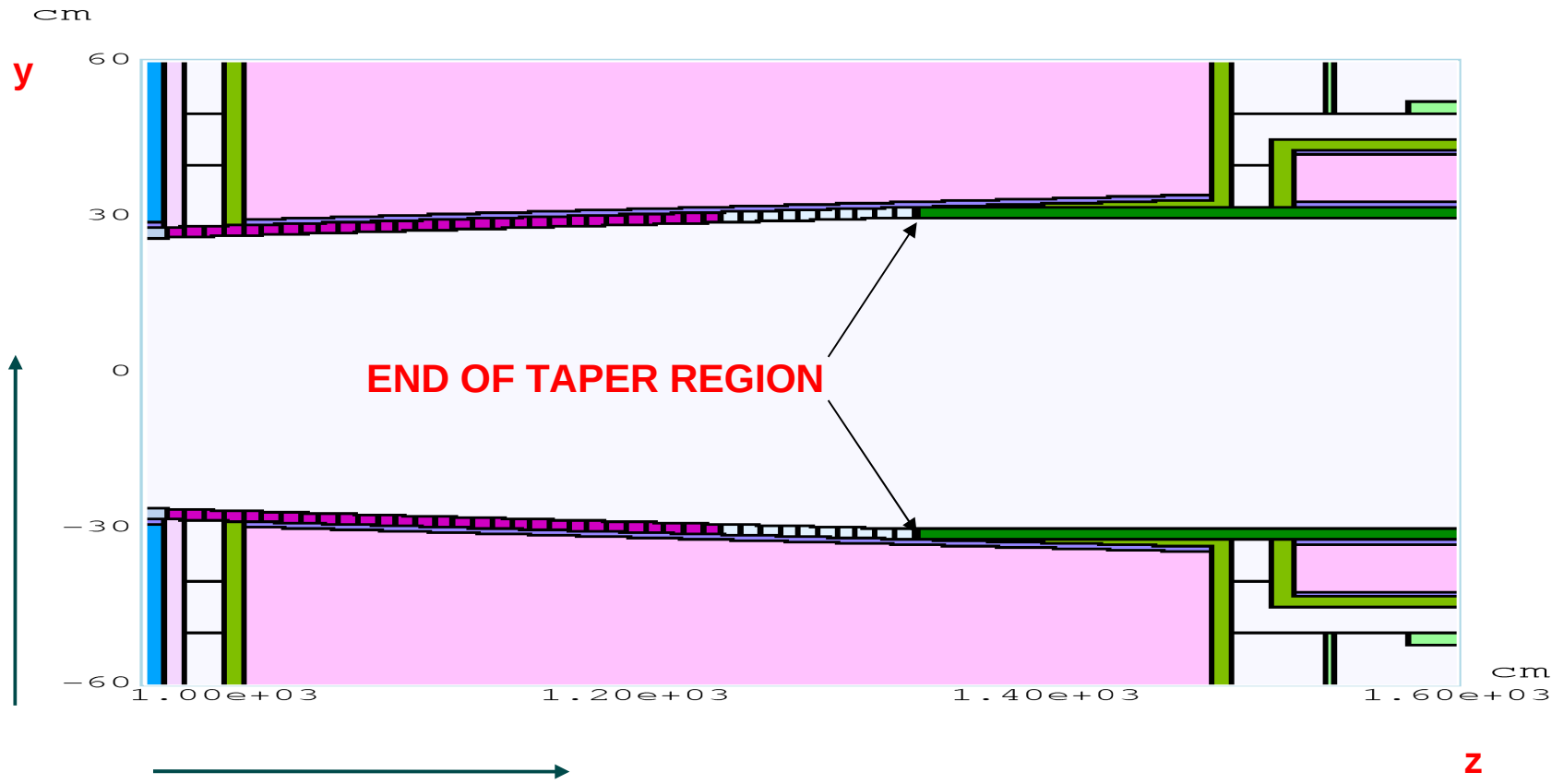

Aspect Ratio: Y:Z = 1:5.33333

$$Rap(z) < r < Rap(z) + dr \text{ cm}$$

$$970.0 < z < 1336.4 \text{ cm}$$

$$0.0 < \varphi < 360.0 \text{ deg.}$$

$$dr = 2.00 \text{ cm}$$

$$dz = 10.18 \text{ cm}$$

$$d\varphi = 30 \text{ deg.}$$

$$N_r = 1 \text{ bins}$$

$$N_z = 36 \text{ bins}$$

$$N_\varphi = 12 \text{ bins}$$

$$N_{\text{tot}} = 432 \text{ "pieces"}$$

Volumes calculated using a closed form expression.

IDS120j: yz AND xy CROSS SECTIONS WITH DETAILS OF THE BP#2 SEGMENTATION

$x = 0.0$

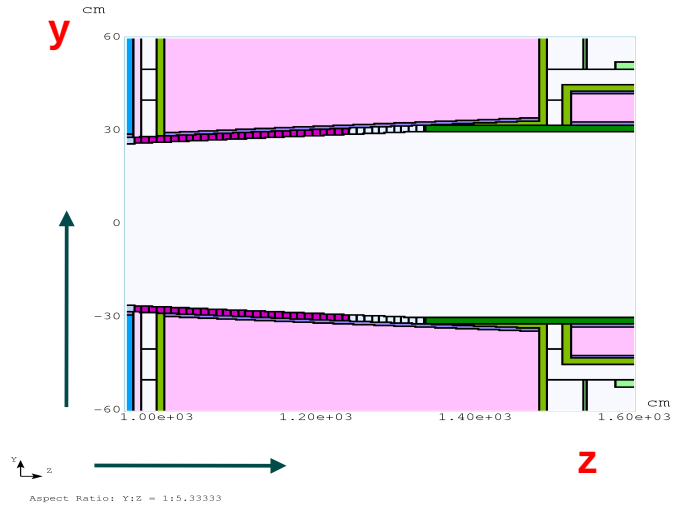

Aspect Ratio: Y:Z = 1:5.33333

$z = 972.0$

$\phi = 90^\circ$

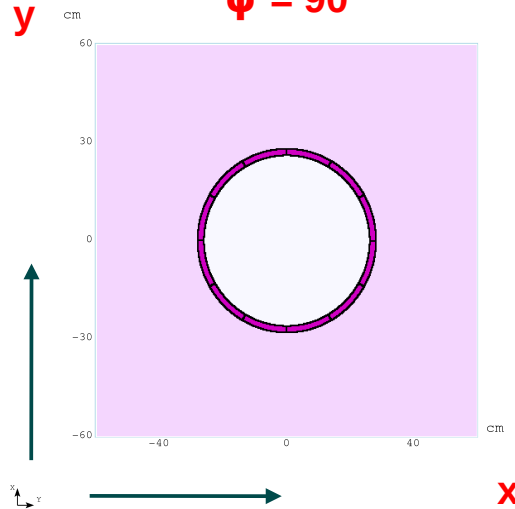

Aspect Ratio: X:Y = 1:1.0

$z = 1000.0$

$\phi = 0^\circ$

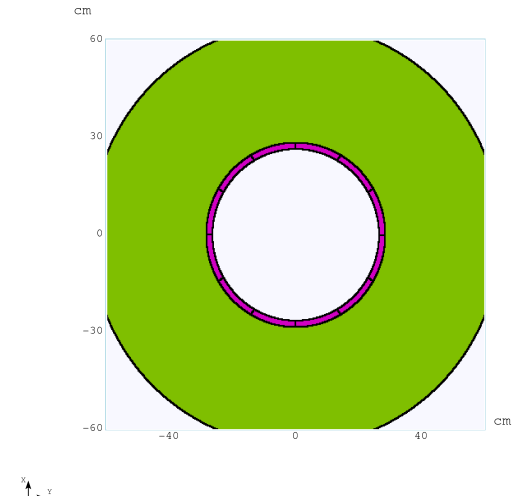

Aspect Ratio: X:Y = 1:1.0

$z = 1100.0$

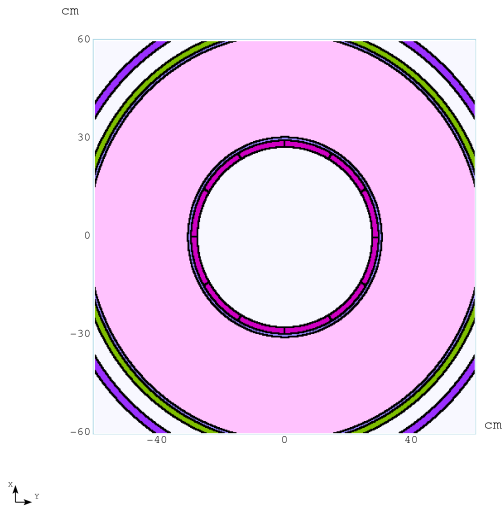

Aspect Ratio: X:Y = 1:1.0

$z = 1200.0$

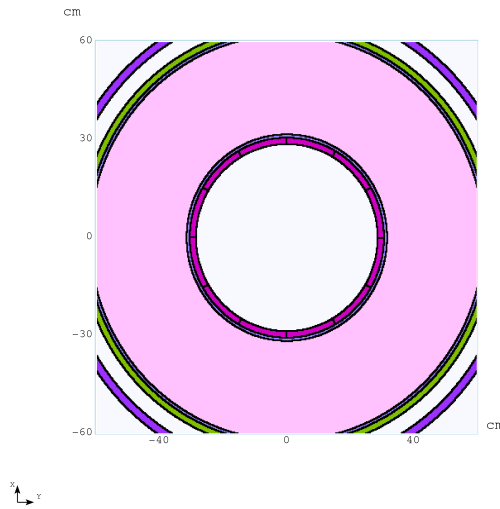

Aspect Ratio: X:Y = 1:1.0

$z = 1300.0$

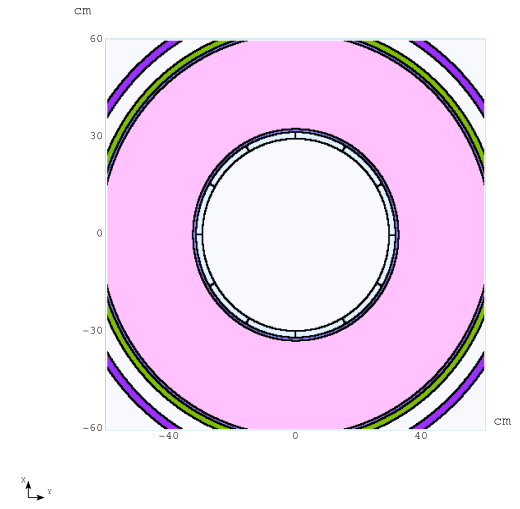

Aspect Ratio: X:Y = 1:1.0

DP vs. z for BP#2 from 970.0 < z < 1336.4 cm (~ CRYO#3), for 12 angles

Coordinates are for the center of each piece, BP is 2.0 cm thick STST (dz= 10.178 cm, dr=2.0 cm, dphi = 30 deg.)

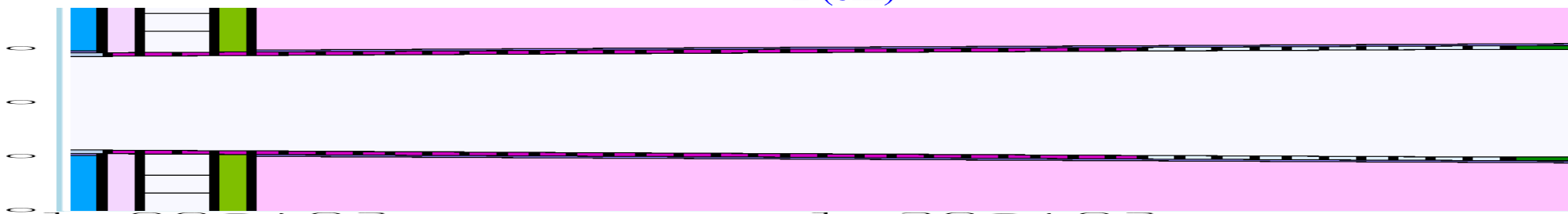
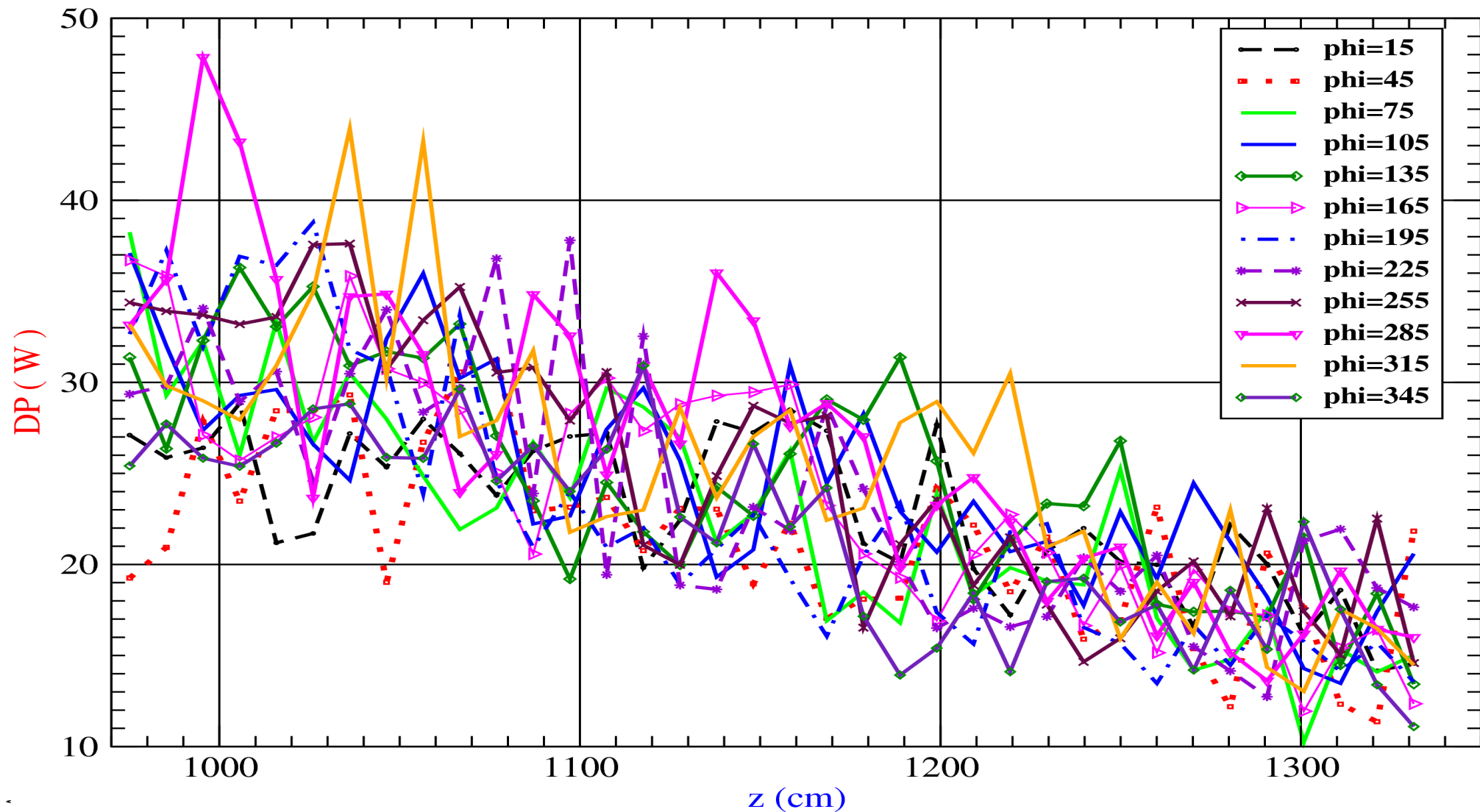

DP vs. z for BP#2 from 970.0 < z < 1336.4 cm (~ CRYO#3), for 12 angles

Coordinates are for the center of each piece, BP is 2.0 cm thick STST (dz= 10.178 cm, dr=2.0 cm, dphi = 30 deg.)

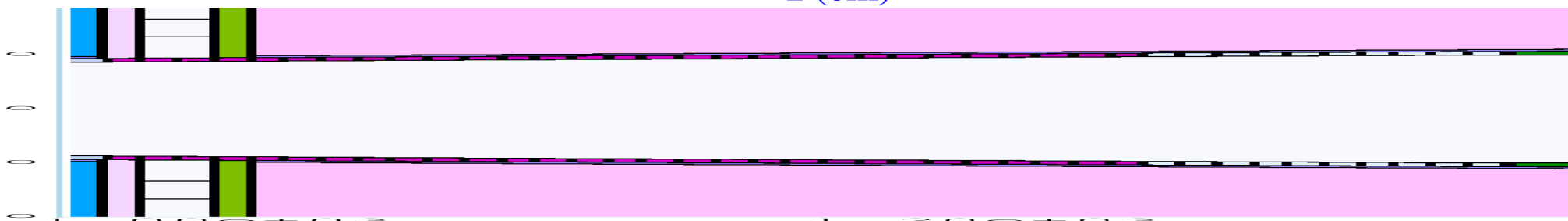
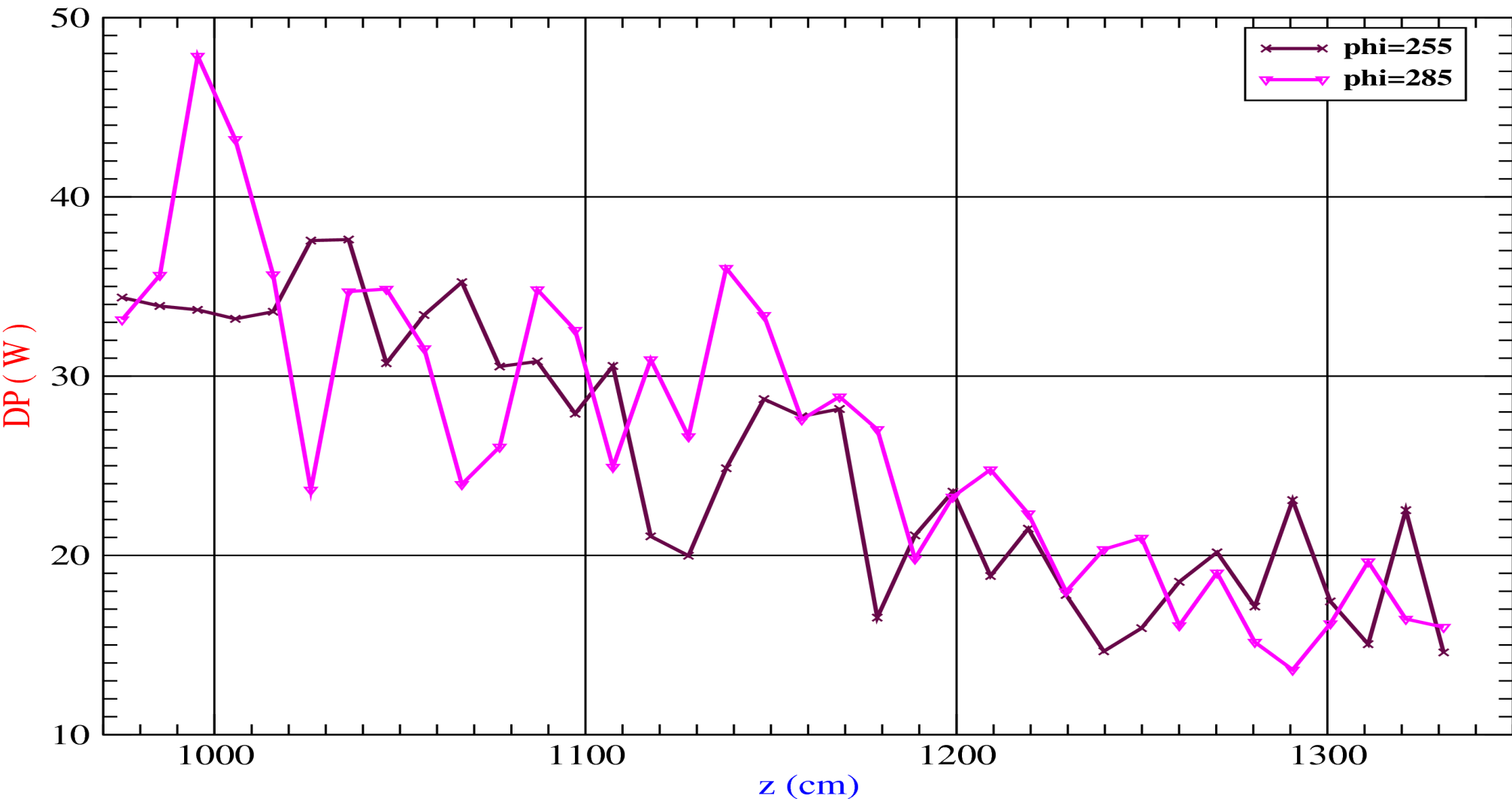

DPD vs. z for BP#2 from $970.0 < z < 1336.4$ cm (\sim CRYO#3), for 12 angles

Coordinates are for the center of each piece, BP is 2.0 cm thick STST (dz= 10.178 cm, dr=2.0 cm, dphi = 30 deg.)

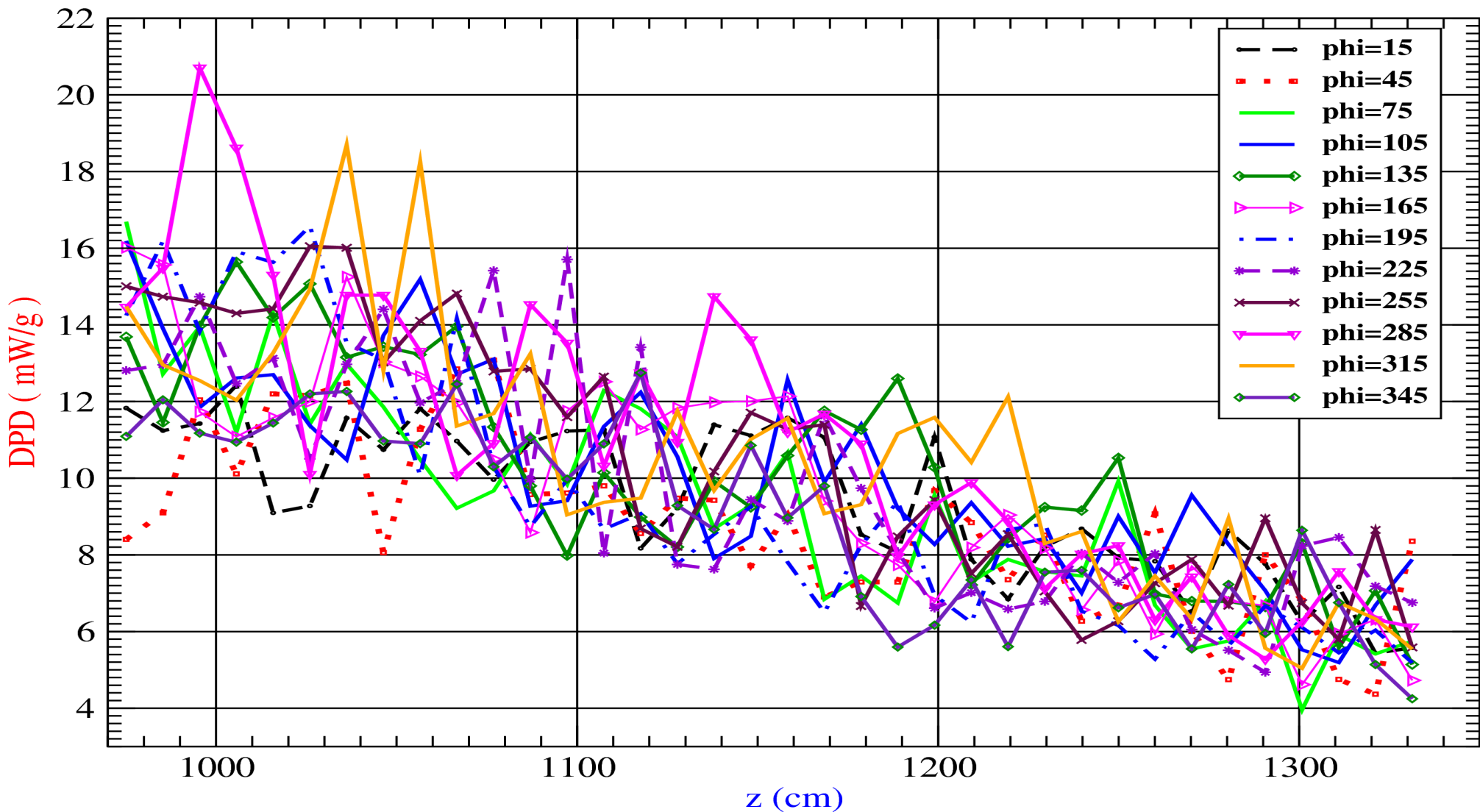

DPD vs. z for BP#2 from 370 < z < 970 cm (CRYO#2), for 2 angles

Coordinates are for the center of each piece, BP is 2.0 cm thick STST (dz= 10.0 cm, dr=2.0 cm, dphi = 30 deg.)

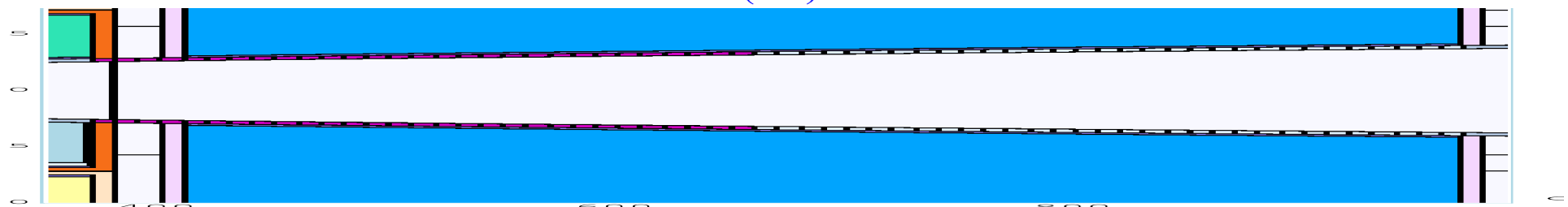
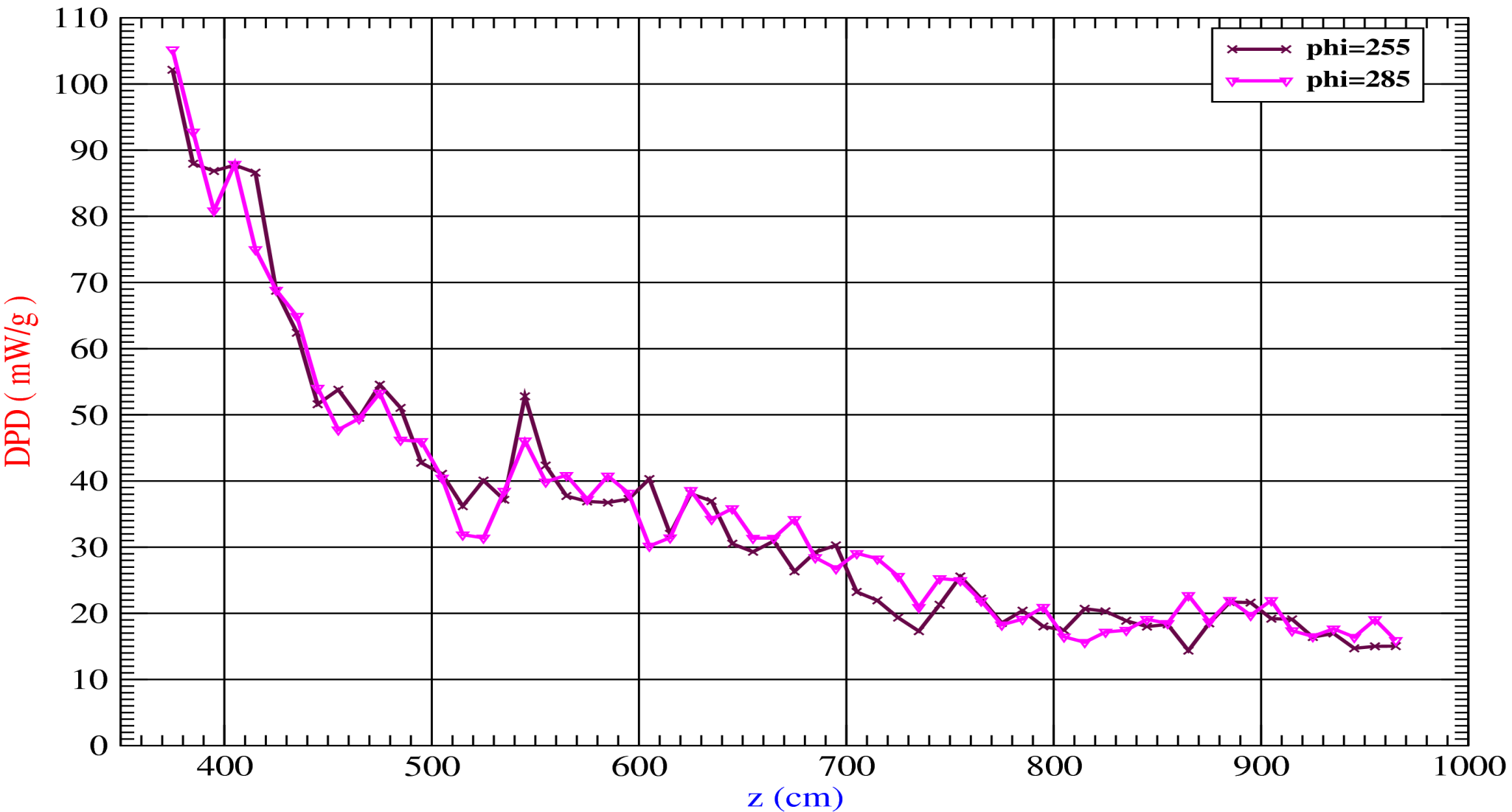

SUM OF DP FROM 432 PIECES :	10.29 kW
DP FROM REST OF BP#2 :	373.40 kW
TOTAL DP IN BP#2 :	384.69 kW
BP#2 DP WITHOUT SEGMENTATION:	384.06 kW

11- 12 kW IS DEPOSITED IN BP#2 PART WITHIN THE THIRD CRYOSTAT WITH ~ 4.5 m LENGTH.

THERE IS STILL NO SMOOTH DECREASE OF THE DP (DPD) WITH z. ONE CAN SEE FOR EXAMPLE RELATIVELY STRONG VARIATIONS IN THE DP (DPD) FOR THE 285 AND 315 DEGREES DISTRIBUTIONS FROM ~ 10 m TO ~ 12 m.

IN GENERAL THERE ARE OSCILLATIONS IN THE DP (DPD) DISTRIBUTION ALONG THE AXIAL DIRECTION WITH DECREASING AMPLITUDE AS THE AVERAGE VALUE OF THESE TWO GRADUALLY DECREASES. IT IS CLEAR THESE VARIATIONS ARE NOT A RESULT OF STATISTICAL UNCERTAINTIES / NOISE.

MAXIMUM DPD IS ~ 18 mW/g NEAR THE BEGINNING OF THE PIPE (WITHIN CRYO#3 REGION) IN THE LOWER HALF OF THE PIPE (~ 285 deg.), WHICH SHOWS THE AZIMUTHAL ASSYMETRY CREATED AT THE TARGET REGION EXIST EVEN AT ~ 10 m DOWNSTREAM.

IDS120j: yz CROSS SECTION WITH DETAILS OF THE BP#2 / BP#3 SEGMENTATION IN CRYO#2 / CRYO#4 REGION

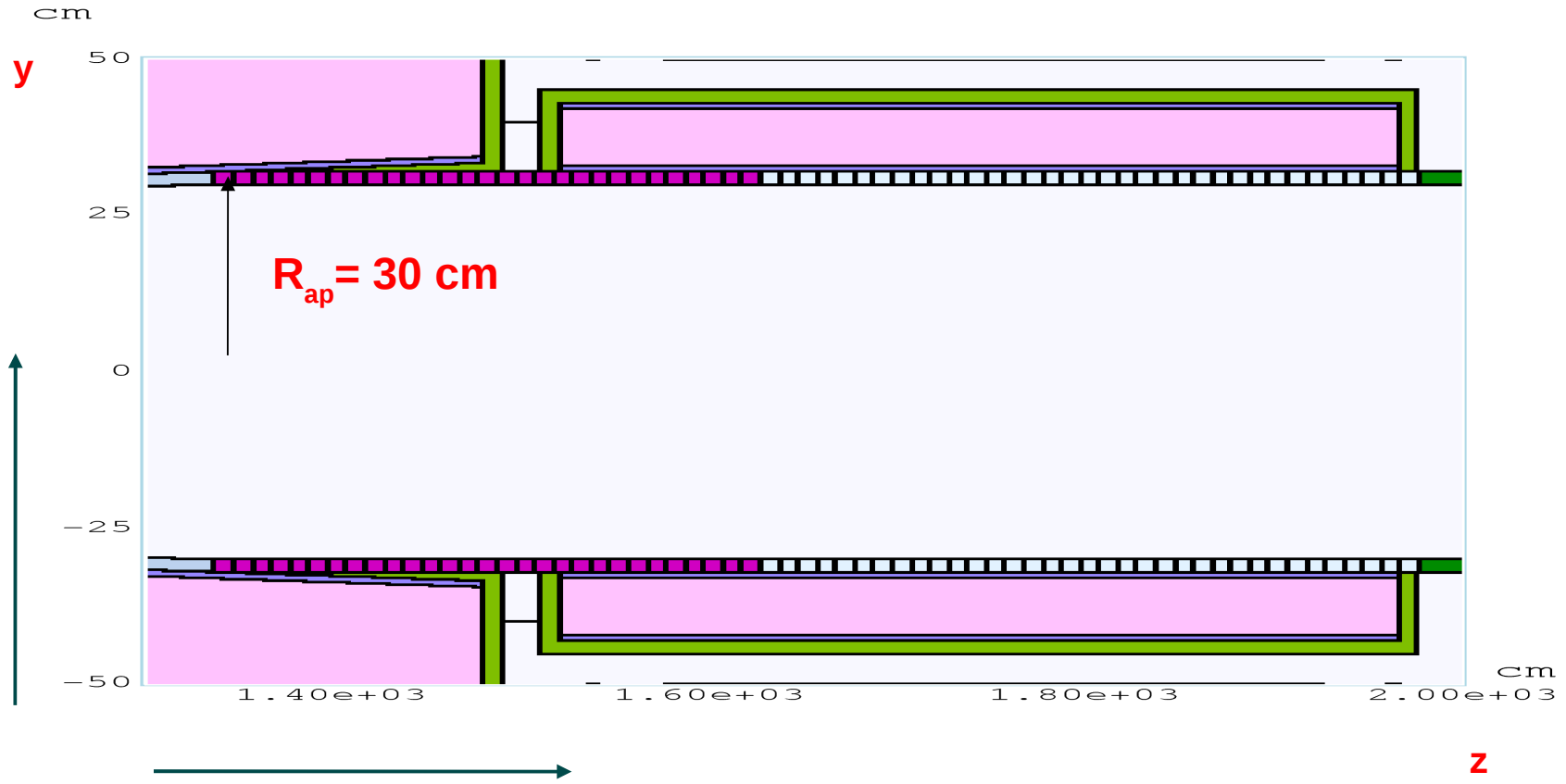

Aspect Ratio: Y:Z = 1:7.0

$30.0 < r < 32.0 \text{ cm}$	$dr = 2.00 \text{ cm}$	$N_r = 1 \text{ bins}$
$1336.40 < z < 1976.40 \text{ cm}$	$dz = 10.00 \text{ cm}$	$N_z = 64 \text{ bins}$
$0.0 < \varphi < 360.0 \text{ deg.}$	$d\varphi = 30 \text{ deg.}$	$N_\varphi = 12 \text{ bins}$
$N_{\text{tot}} = 768 \text{ "pieces"}$		

IDS120j: yz AND xy CROSS SECTIONS WITH DETAILS OF THE BP#2 / BP#3 SEGMENTATION

$x = 0.0$

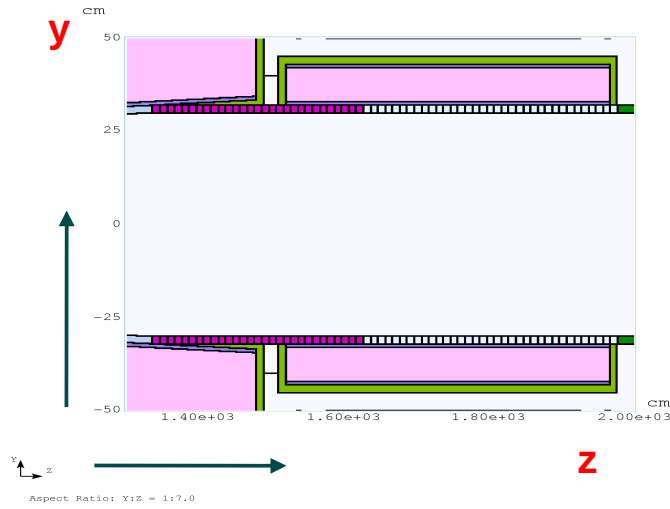

$z = 1337.0$

$\phi = 90^\circ$

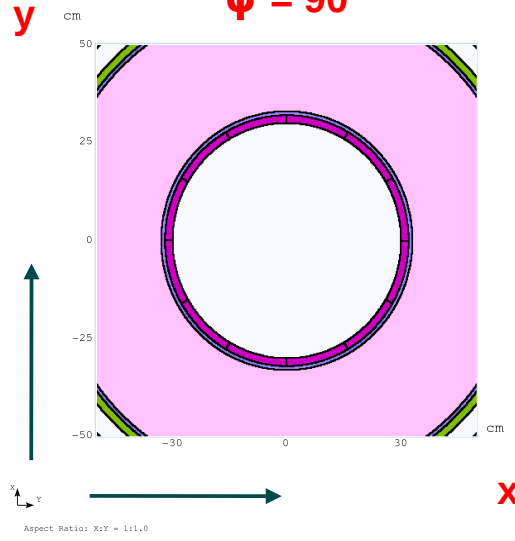

$z = 1437.0$

$\phi = 0^\circ$

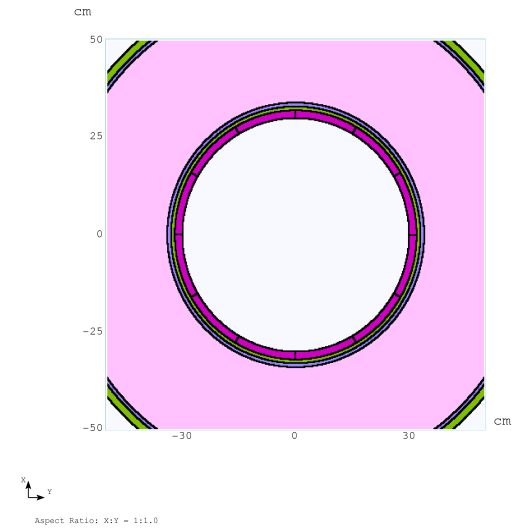

$z = 1637.0$

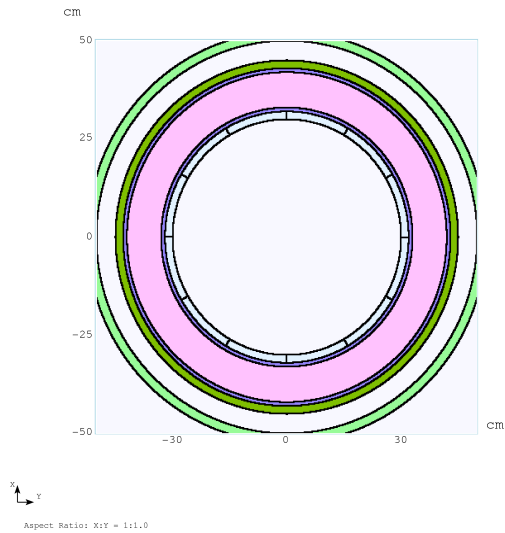

$z = 1837.0$

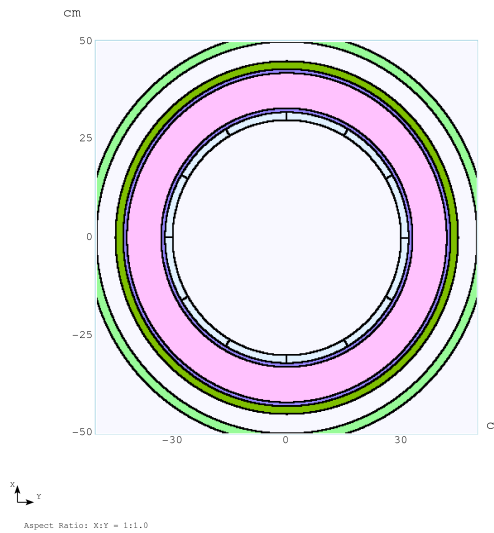

$z = 1975.0$

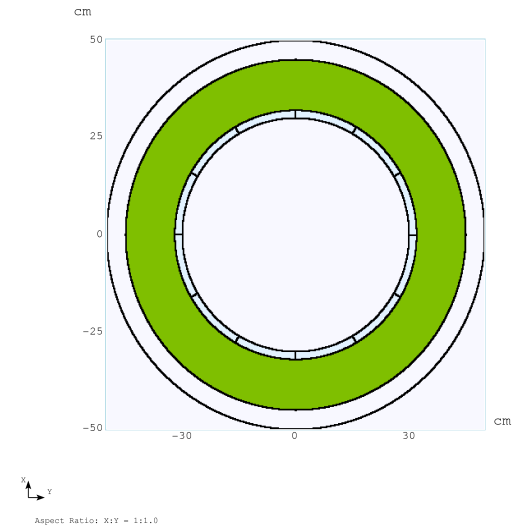

DP vs. z for BP#3 from 1336.4 < z < 1976.4 cm (~ CRYO#4), for 12 angles

Coordinates are for the center of each piece, BP is 2.0 cm thick STST (dz= 10.0 cm, dr=2.0 cm, dphi = 30 deg.)

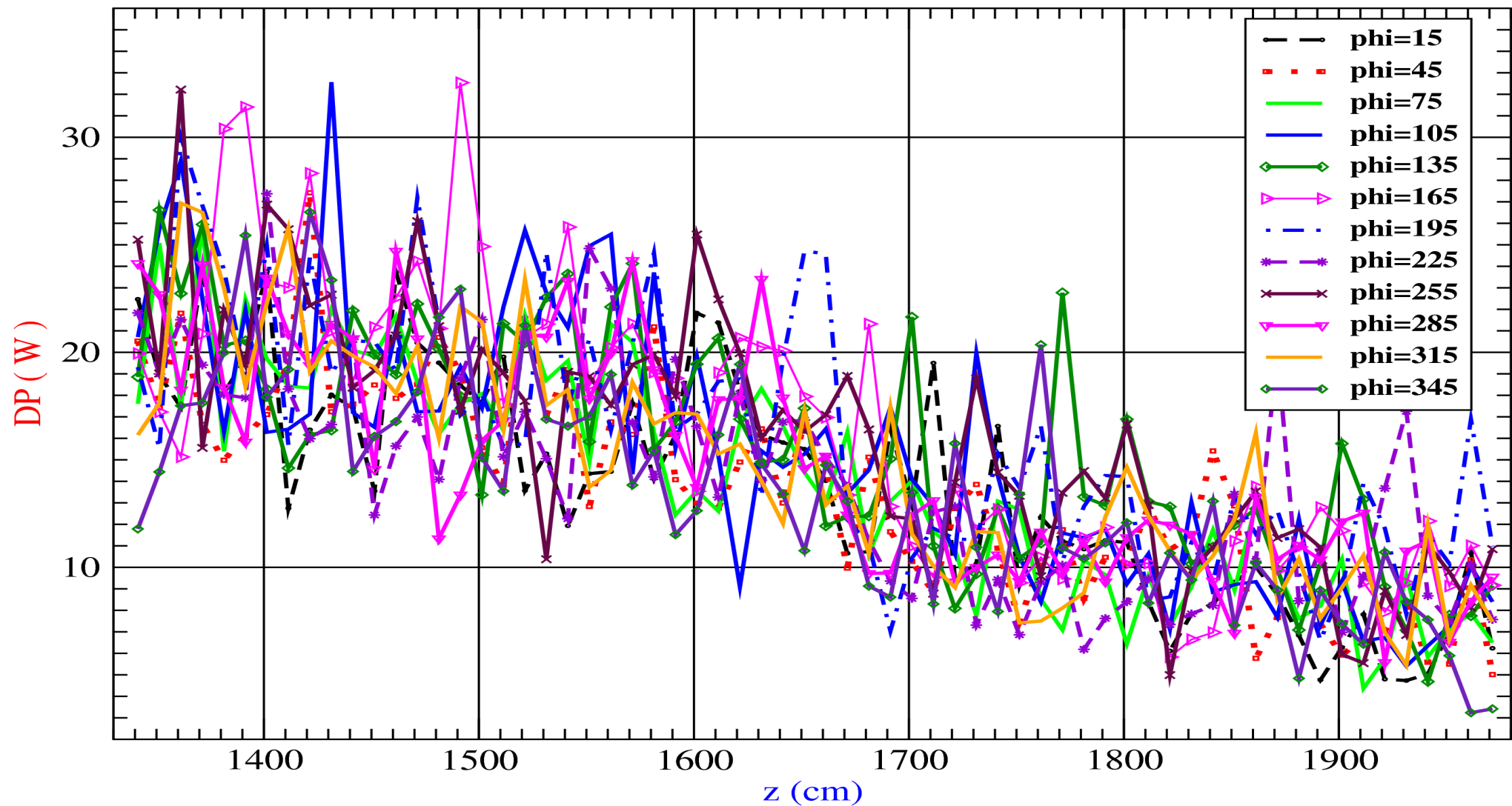

DP vs. z for BP#3 from 1336.4 < z < 1976.4 cm (~ CRYO#4), for 12 angles

Coordinates are for the center of each piece, BP is 2.0 cm thick STST (dz= 10.0 cm, dr=2.0 cm, dphi = 30 deg.)

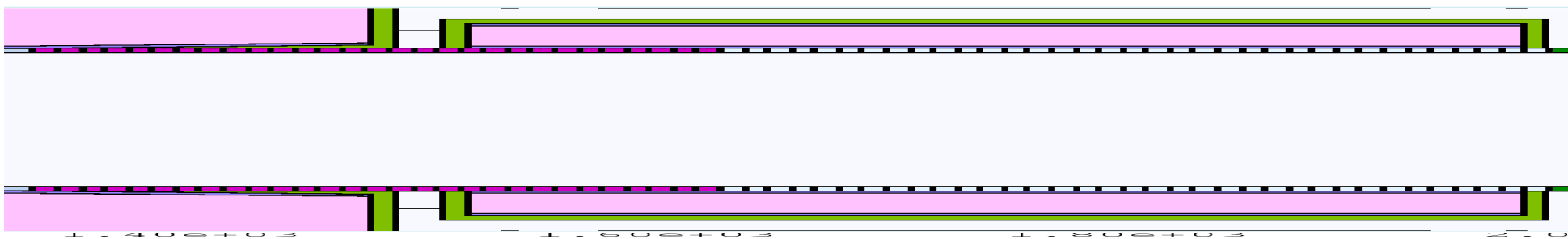
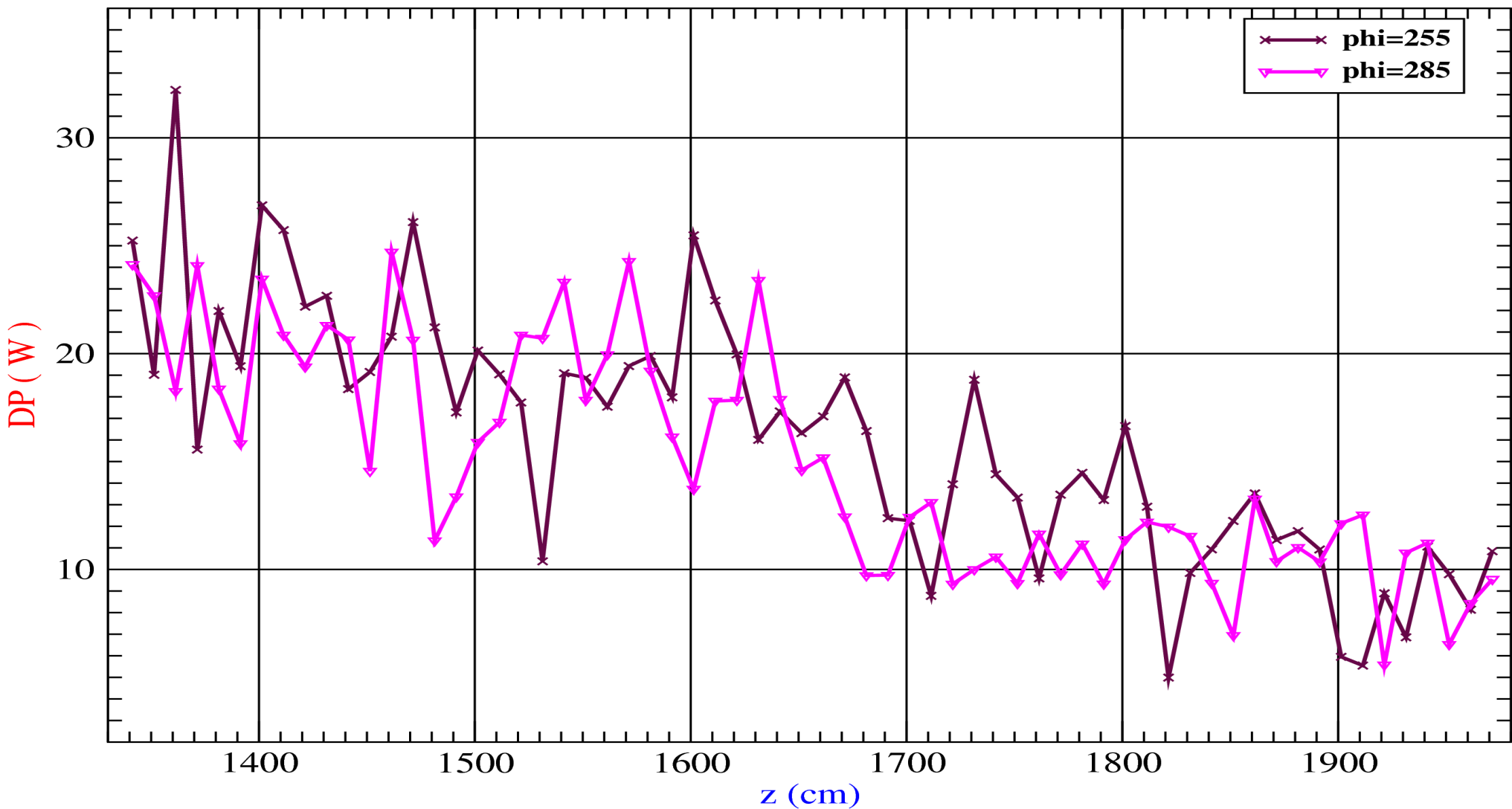

DPD vs. z for BP#3 from 1336.4 < z < 1976.4 cm (~ CRYO#4), for 12 angles

Coordinates are for the center of each piece, BP is 2.0 cm thick STST (dz= 10.0 cm, dr=2.0 cm, dphi = 30 deg.)

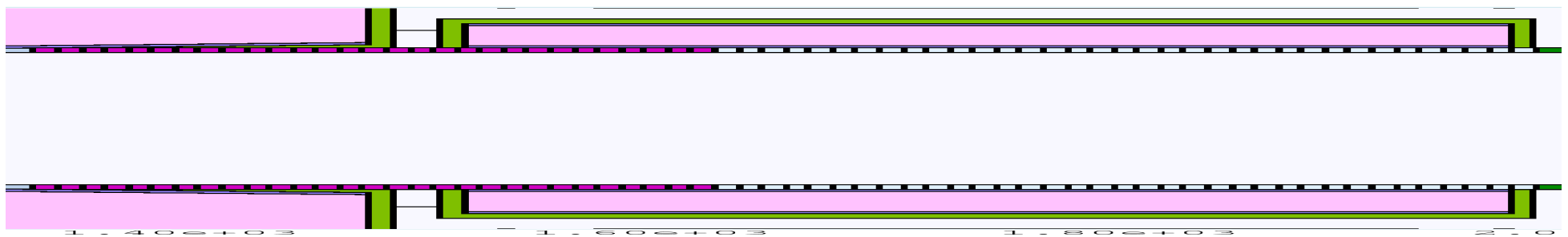
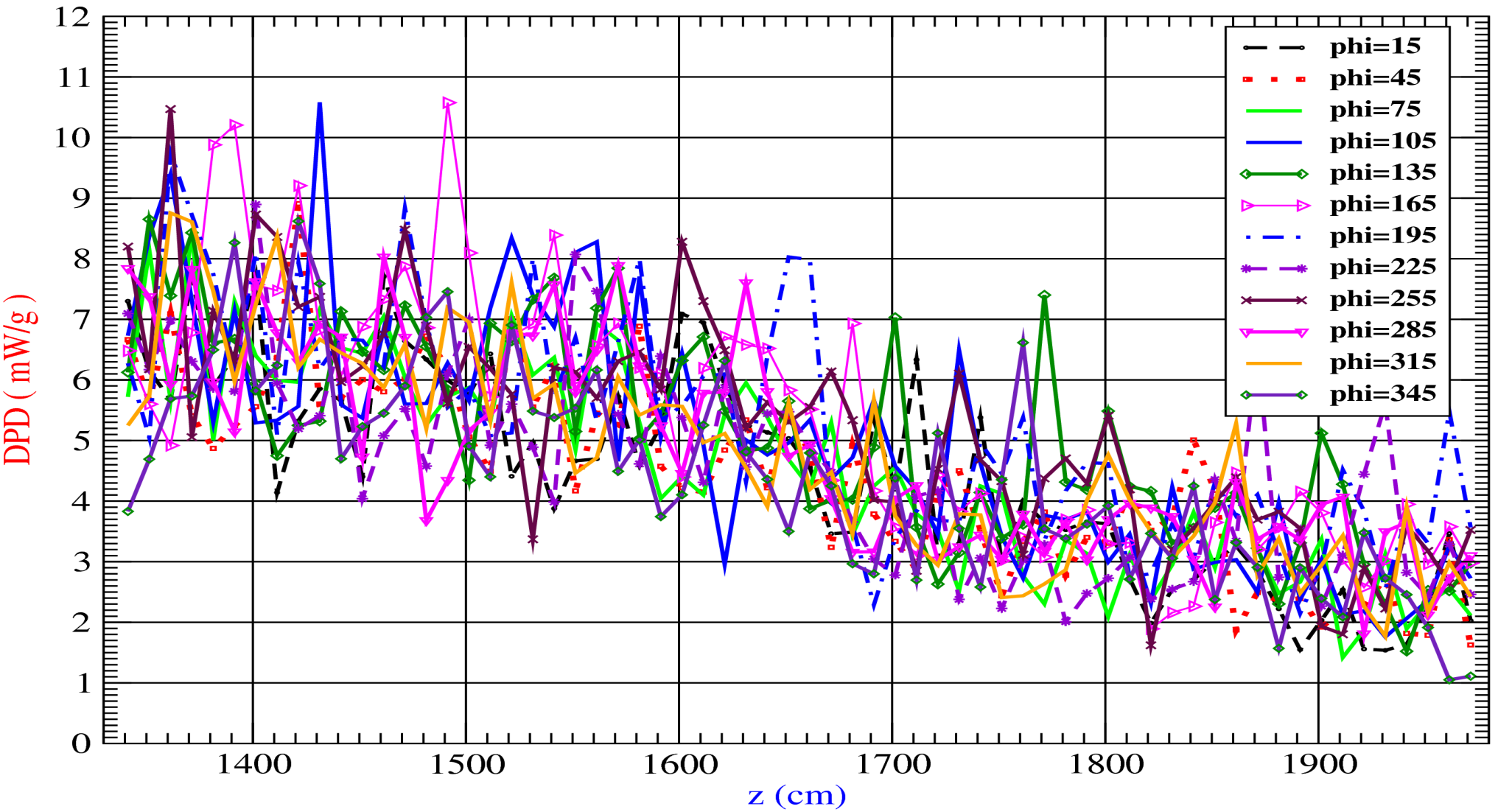

DPD vs. z for BP#3 from 1336.4 < z < 1976.4 cm (~ CRYO#4), for 12 angles

Coordinates are for the center of each piece, BP is 2.0 cm thick STST (dz= 10.0 cm, dr=2.0 cm, dphi = 30 deg.)

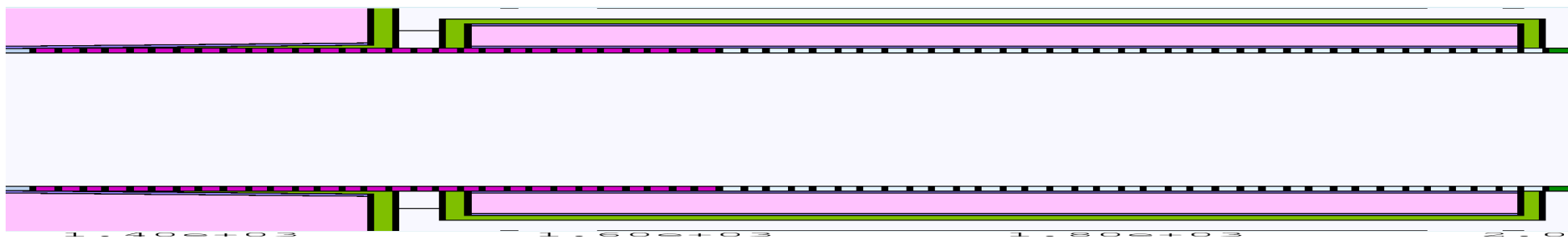
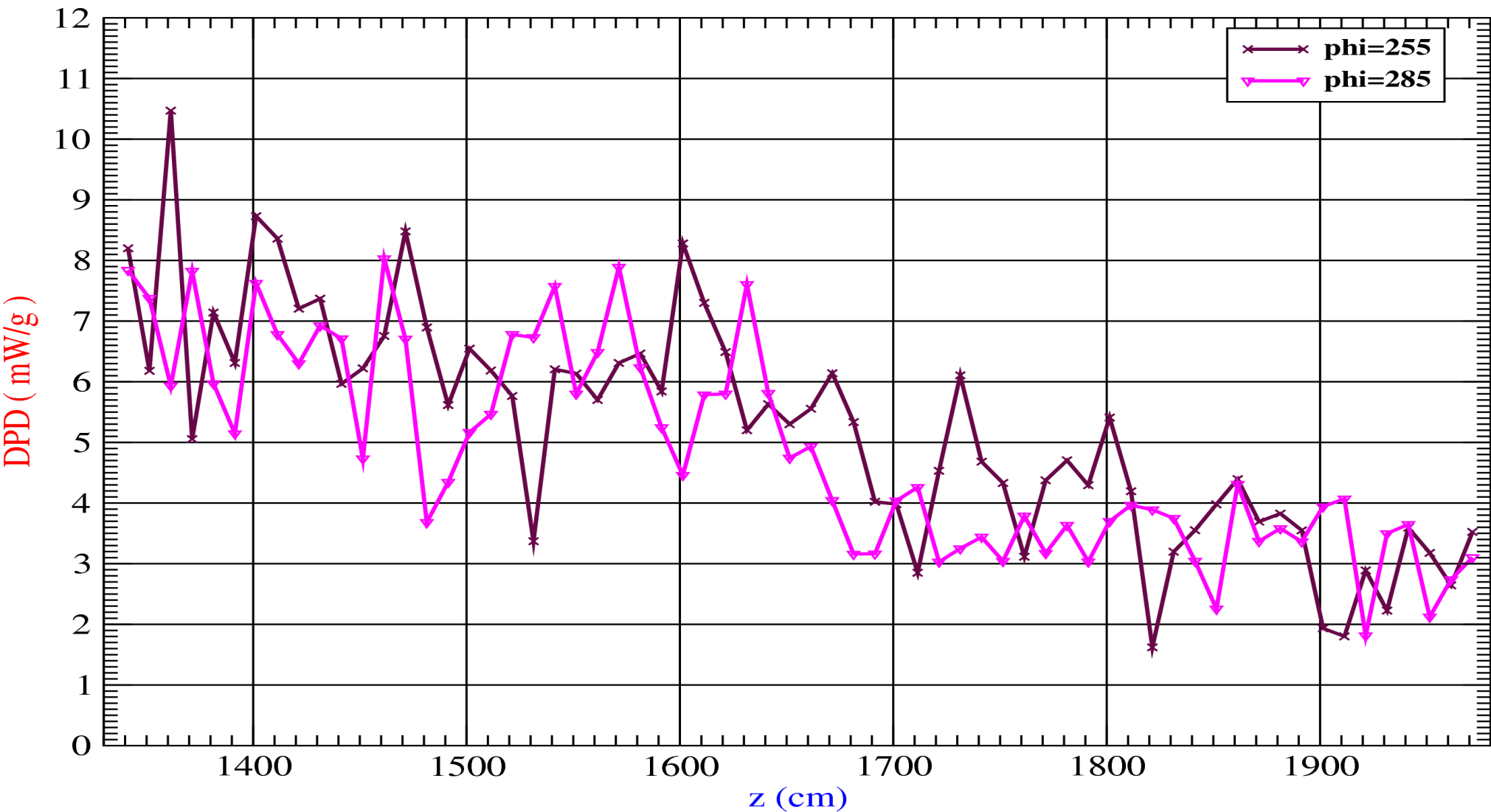

SUM OF DP FROM 768 PIECES :	11.36 kW
DP FROM REST OF BP#3 :	7.04 kW
TOTAL DP IN BP#3 :	18.40 kW
BP#3 DP WITHOUT SEGMENTATION:	17.79 kW

~ 7 kW IS DEPOSITED IN BP#3 PART WITHIN THE FOURTH CRYOSTAT WITH ~ 4.5 m LENGTH.

RELATIVE LARGE FLUCTUATIONS APPEAR TO BE NOW IN ALMOST ALL DIRECTIONS. THEY DON'T APPEAR TO BE DUE TO STATISTICAL UNCERTAINTIES.

MAXIMUM DPD IS ~ 11 mW/g NEAR THE BEGINNING OF THE PIPE (WITHIN CRYO#4 REGION)
z ~ 1500 cm ALONG THE - x DIRECTION.