



# High-intensity muon source: Status and future plans

Diktys Stratakis

Brookhaven National Laboratory

MAP Winter Meeting

December 04, 2014

SLAC, Menlo Park, CA, USA

# Outline

- Work plan for FY 2015
- Review (briefly) progress on major sub-systems
  - Target & Capture Solenoid
  - Chicane
  - Drift Channel
  - Buncher
  - Phase-Rotator
- Future work

# Work plan

- Optimize C target with MARS (for a 1 MW, 6.75 GeV proton driver) [Ding]
- Produce design specs for the chicane [Berg, Neuffer]
- Concept specification for buncher & phase-rotator and evaluate performance [Neuffer]
- Energy deposition along accelerator components [Snopok, Bao, Stratakis]
- Utilize gas filled cavities [Stratakis]
- Submit results to JINST no later than June 2015

# Target & capture system

- New target concept:
  - Solid target module inside a high-field solenoidal magnet
  - 1 MW initial beam power
- Details: K.T. McDonald Talk on Dec 5th, 2:00 pm

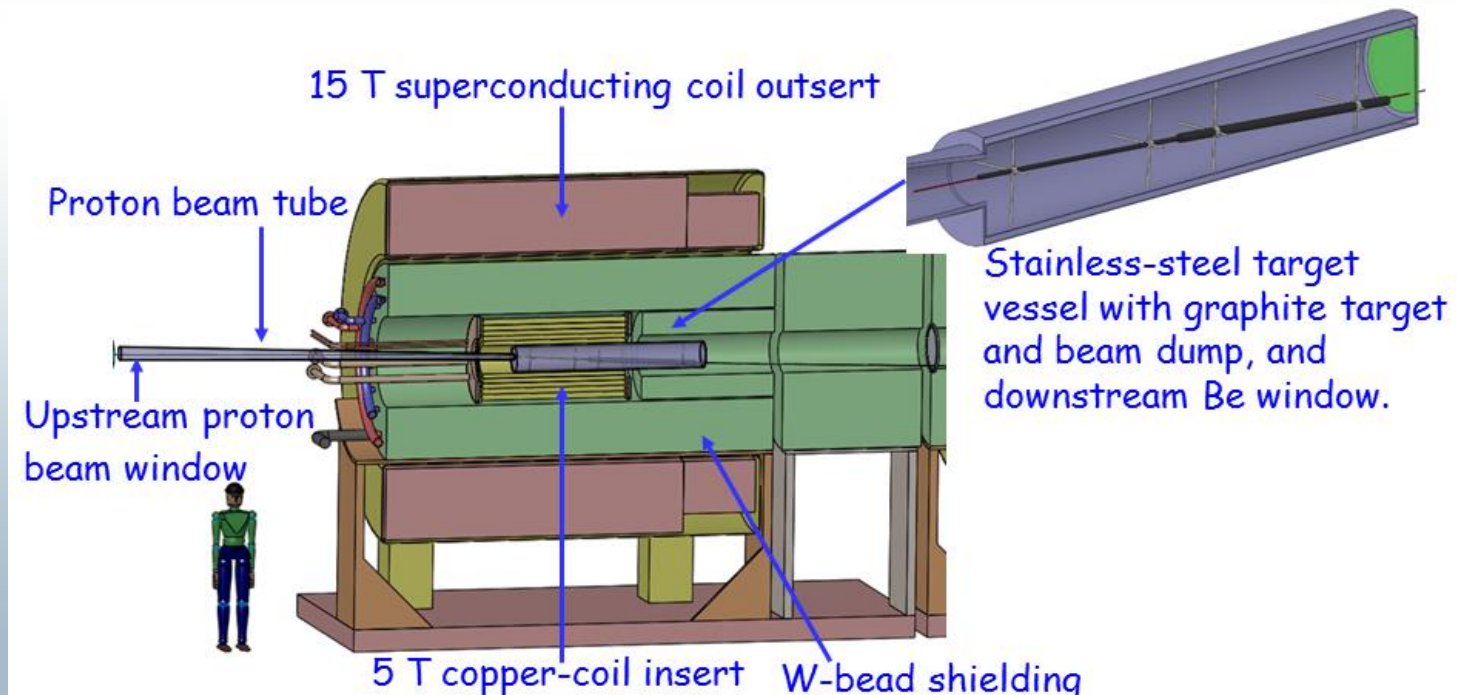

# Target system optimizations

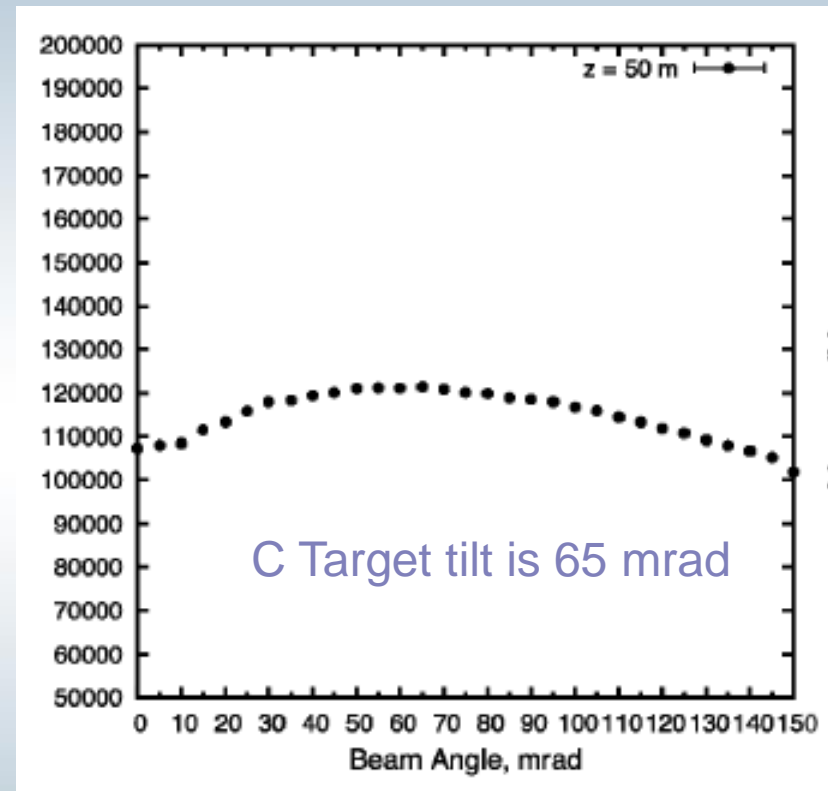
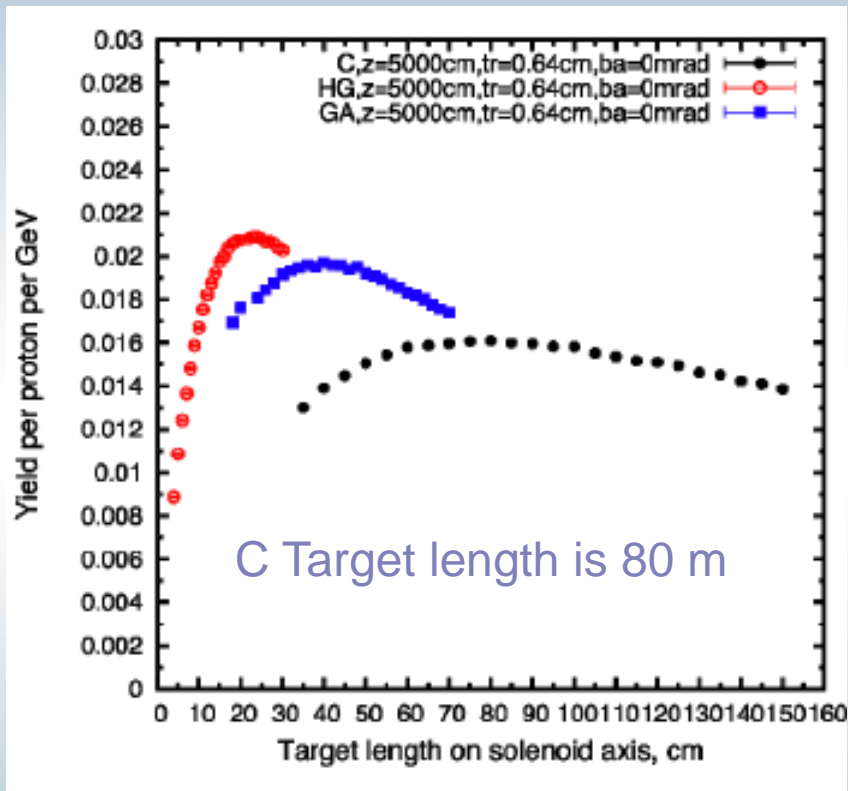

- Target is fully optimized with MARS
- Details: X. Ding, Talk on Dec. 4<sup>th</sup>, 11:30 am

# Taper magnet design

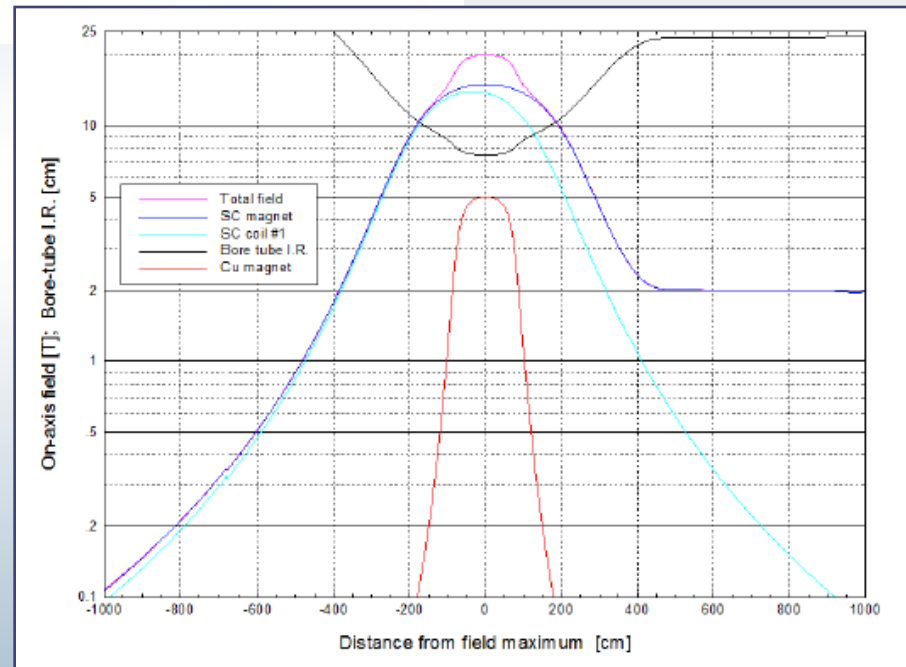
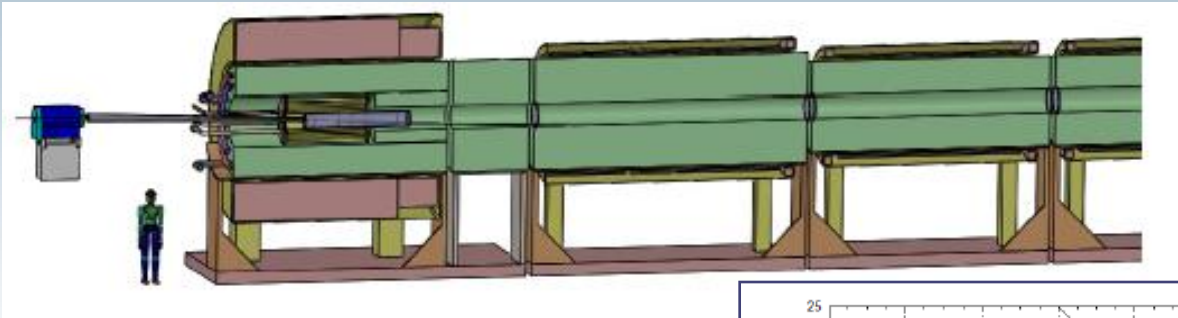

- Magnet design for a 5 m taper from 20 T to 2 T delivered
- Integrated to the new muon source lattice

# Solenoidal chicane

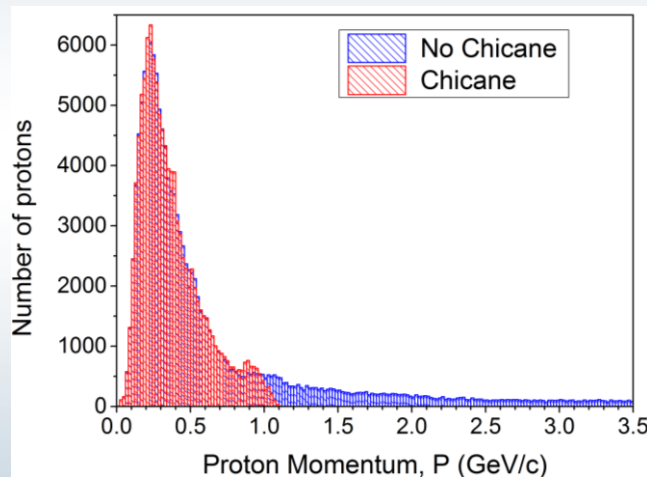
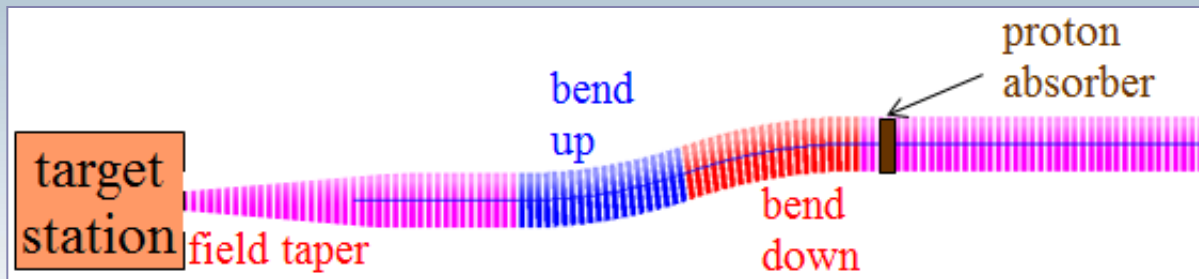

- We are in this process of studying this concept to understand what design choices best reduce unwanted energy deposition while maintaining transmitted muon flux

# Chicane optimization

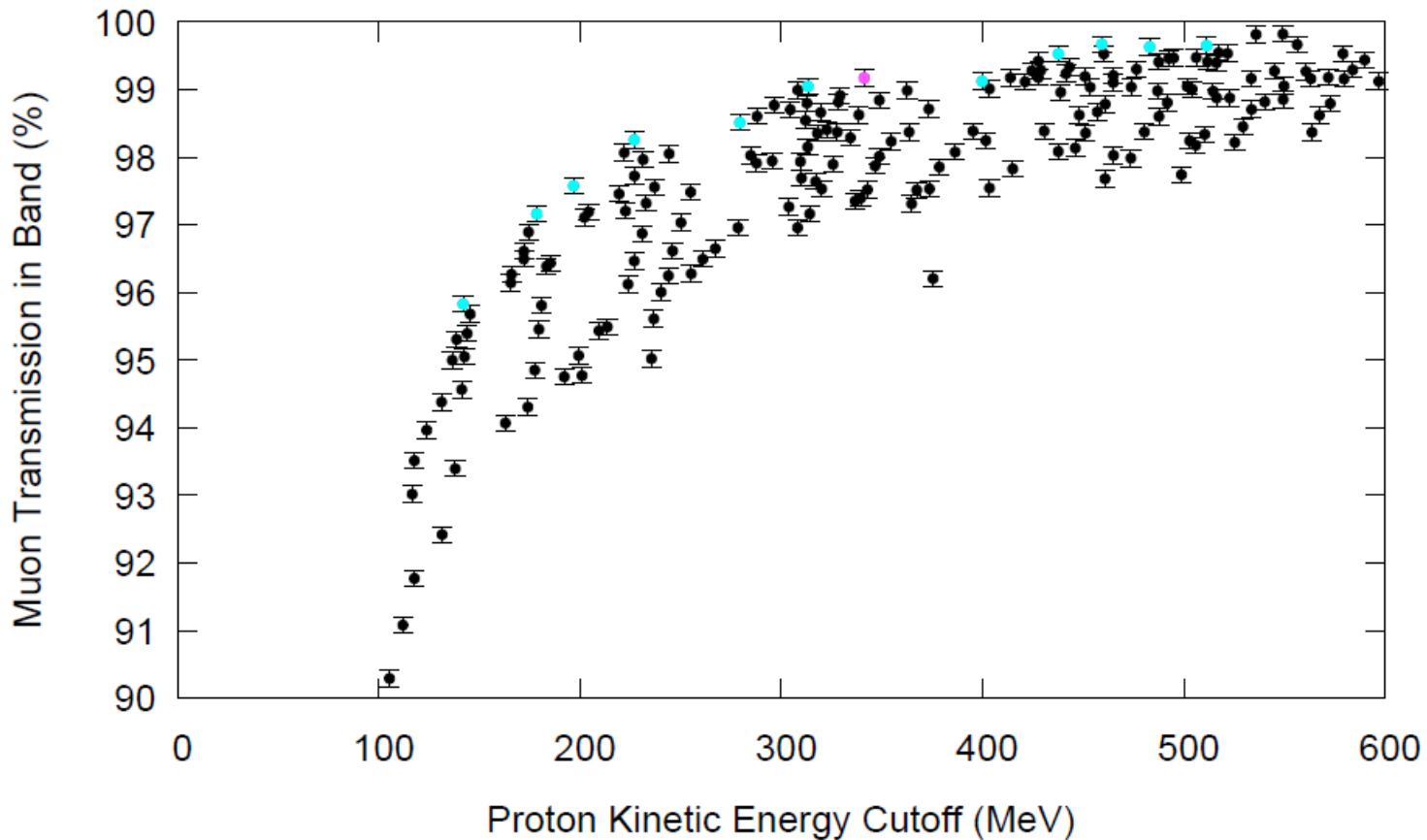

- Details: J.S. Berg Talk on Dec 4<sup>th</sup>, 12:05 pm



# Energy deposition

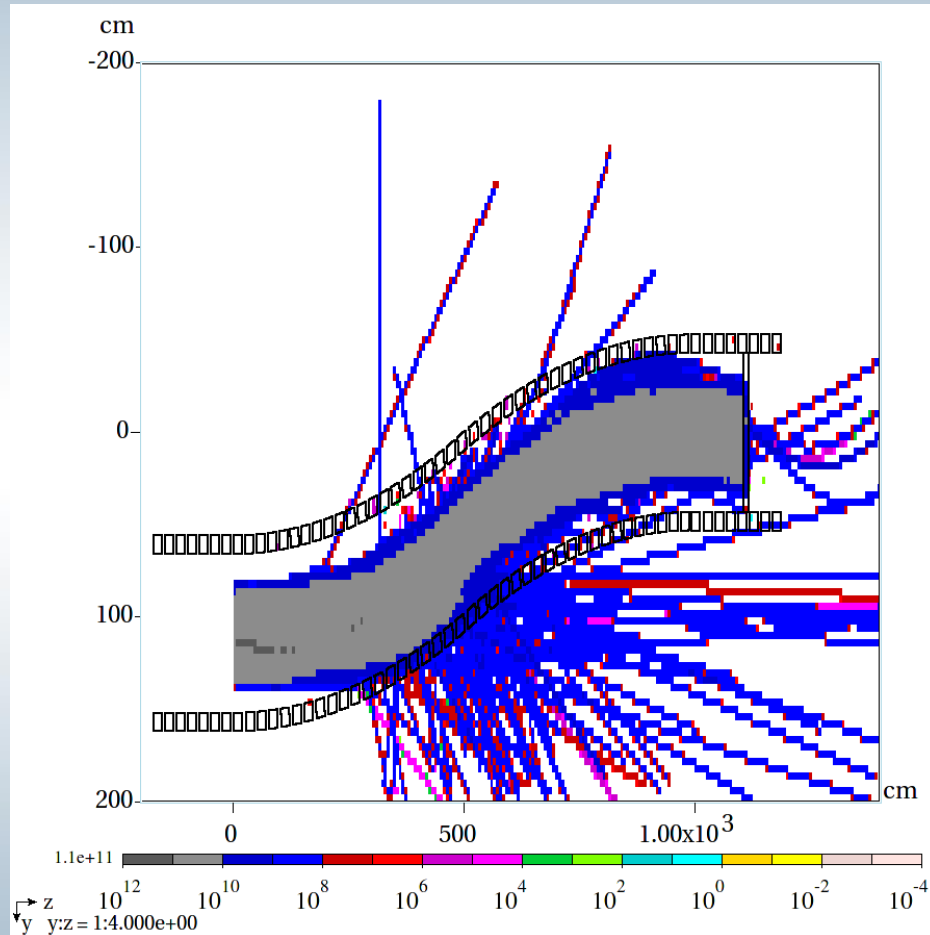

- Energy Dep. Talk: P. Snopok on Dec 4<sup>th</sup>, 12:25 pm

# Buncher & Rotator

- Specify parameters for buncher and phase-rotator (length, rf frequency & gradient) and evaluate performance for the new target specifications
- Details: D. Neuffer, Talk on Dec. 4<sup>th</sup>, 11:45 pm
- Present design are based on vacuum rf cavities only

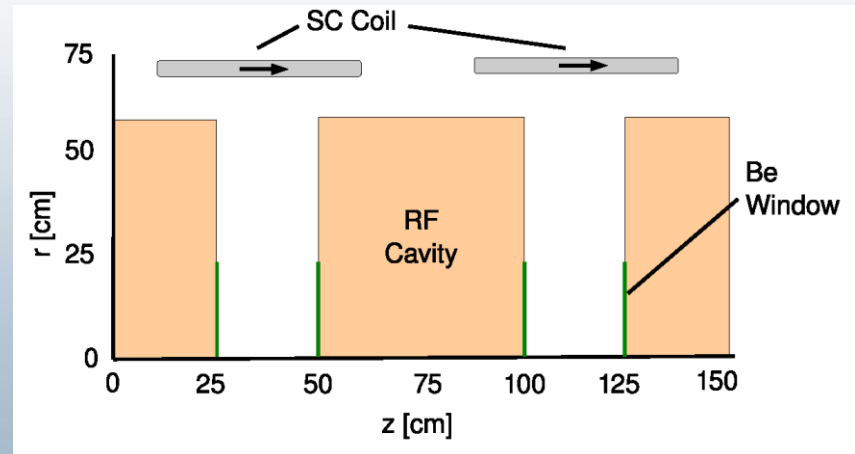

# Muon source with gas filled cavities

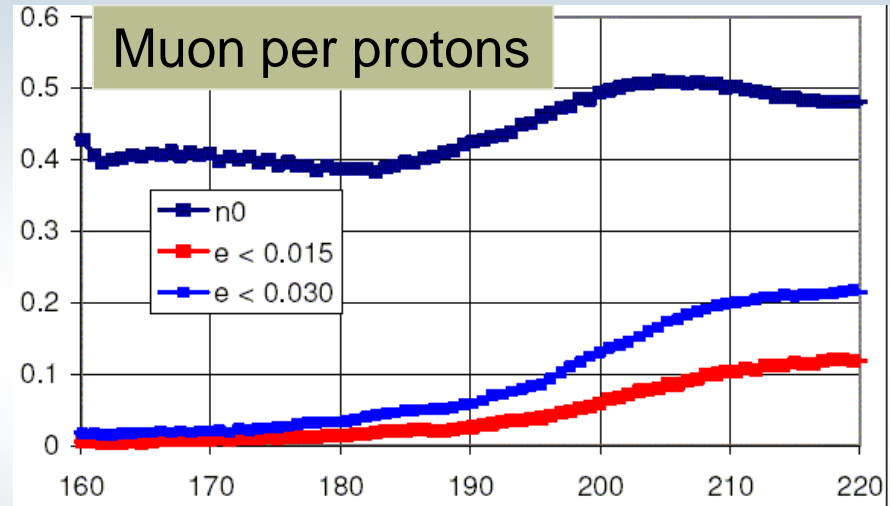
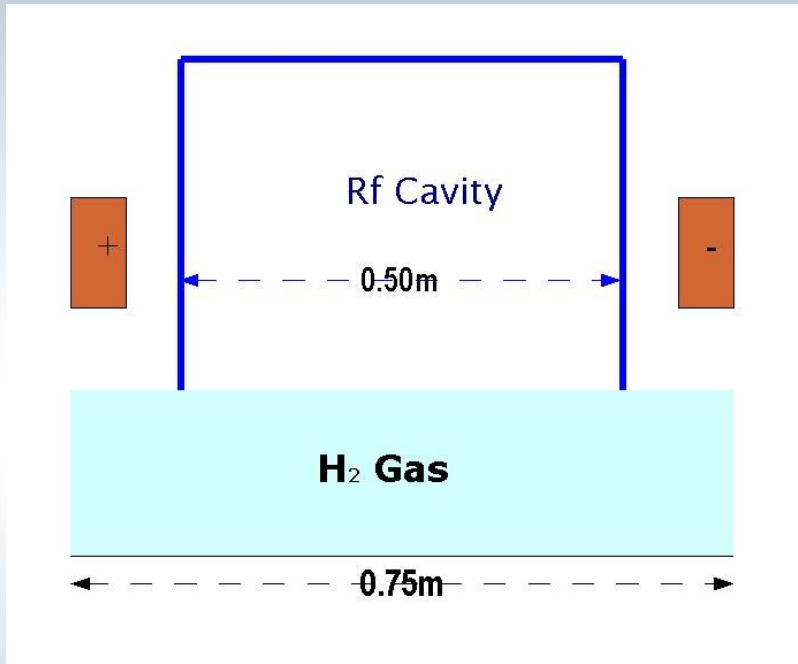

- A first study presented at PAC 2009 by Neuffer et al.
- Improve matching, sensitivity with gas pressure, best “realistic” scenario...
- To be presented in IPAC 2015

# Further activities (lack of resources)

- Integrate Yuri's 6D cooler with the muon source
- Use MARS to study energy deposition downstream the chicane
- Find the maximum polarization we can achieve by changing parameters of our current design
- Study more radical modifications to our system that could achieve even greater polarization
- Expand the range of applications to which our muon sources could be applied
  - Application besides neutrino factories and muon colliders

# What's next

- You will hear more results from our speakers
- We have submitted three abstracts for IPAC 15
- Biweekly phone meetings
- Maintain a web page with all files and presentations
- We are happy to hear new suggestions