

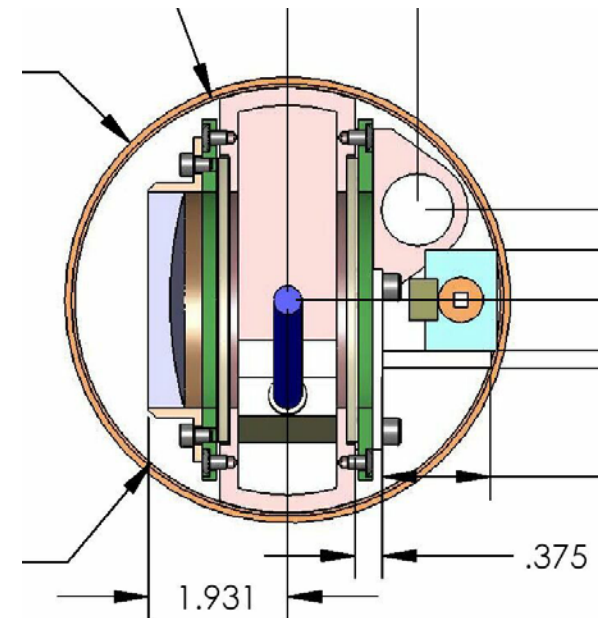

Optical Diagnostics

- tight environment
- high radiation area
- non-serviceable area
- passive components
- optics only, no active electronics
- transmit image through flexible fiber bundle





Optical Diagnostics

optical design in secondary containment

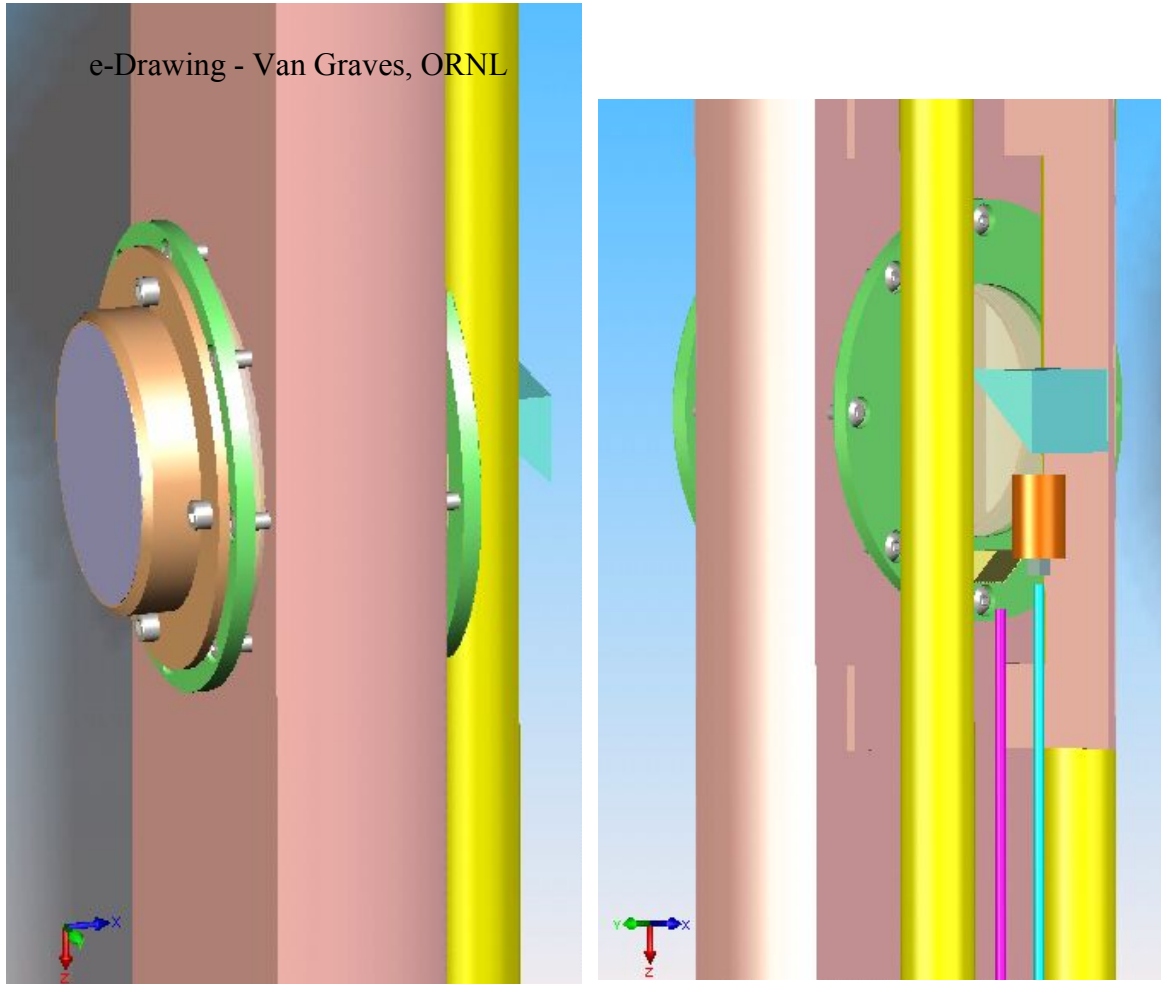

One set of optics
per viewport

Conceptual design
completed

- issues on the imaging fiber bundle

Fujikura imaging fibers

Table 3

ULTRATHIN IMAGEFIBER SPECIFICATIONS

(FIGH series N-Type 50k-100k)

Item	FIGH-50-1100N	FIGH-70-1300N	FIGH-100-1500N
Number of picture elements (nominal)	50,000 (Nominal)	70,000 (Nominal)	100,000 (Nominal)
Imagecircle diameter (μm)	1,025 +80/-80	1,200 +100/-100	1,400 +120/-120
Fiber diameter (μm)	1,100 +80/-80	1,300 +100/-100	1,500 +120/-120
Coating diameter (μm)	1,200 +100/-100	1,450 +100/-100	1,700 +150/-150
Minimum bending radius (mm)	110 ^{*1} (80 ^{*2})	150 ^{*1} (100 ^{*2})	200 ^{*1} (130 ^{*2})
Coating material	Silicone resin		
Lattice defect (%)	< 0.1		
Uncircularity (%)	< 5		

*1: Minimum bending radius in storage

*2: Recommended bending radius in use (For your reference only, possibly to be happened breakage by static fatigue.)



ULTRATHIN IMAGEFIBER SPECIFICATIONS

(FIGH series S-Type 1.6k-10k)

Table 1

Item	FIGH-016-160S	FIGH-03-215S	FIGH-06-300S	FIGH-10-350S
Number of picture elements (nominal)	1,600	3,000	6,000	10,000
Imagecircle diameter (μm)	140 ± 15	190 ± 20	270 ± 20	325 ± 20
Fiber diameter (μm)	160 ± 20	215 ± 25	300 ± 25	350 ± 25
Coating diameter (μm)	210 ± 30	285 ± 30	400 ± 30	450 ± 30
Minimum bending radius (mm)	20 ^{*1} ₋₁₀ ^{*2}	25 ^{*1} ₋₁₅ ^{*2}	30 ^{*1} ₋₁₅ ^{*2}	35 ^{*1} ₋₂₀ ^{*2}
Coating material	Silicone resin			
Lattice defect (%)	< 0.1			
Uncircularity (%)	< 5			
Length/pc	Maximum length of 1pc : 30ft Cut and rough polish are available. Cut length of 1pc : Customer order			

*1: Minimum bending radius in storage

*2: Recommended bending radius in use

ULTRATHIN IMAGEFIBER SPECIFICATIONS

(FIGH series H-Type 10k-15k)

Table 2

Item	FIGH-10-500N	FIGH-15-600N
Number of picture elements (nominal)	10,000	15,000
Imagecircle diameter (μm)	460 ± 25	550 ± 30
Fiber diameter (μm)	500 ± 25	600 ± 30
Coating diameter (μm)	600 ± 35	700 ± 35
Minimum bending radius (mm)	50 ^{*1} ₋₂₅ ^{*2}	60 ^{*1} ₋₃₀ ^{*2}
Coating material	Silicone resin	
Lattice defect (%)	< 0.1	
Uncircularity (%)	< 5	
Length/pc	Maximum length of 1pc : 30ft Cut and rough polish are available. Cut length of 1pc : Customer order	

*1: Minimum bending radius in storage

*2: Recommended bending radius in use

ULTRATHIN IMAGEFIBER SPECIFICATIONS

(FIGH series N-Type 50k-100k)

Table 3

Item	FIGH-30-850N	FIGH-50-1100N	FIGH-70-1300N	FIGH-100-1500N
Number of picture elements (nominal)	30,000	50,000	70,000	100,000
Imagecircle diameter (μm)	790 ± 50	1,025 ± 80	1,200 ± 100	1,400 ± 120
Fiber diameter (μm)	850 ± 50	1,100 ± 80	1,300 ± 100	1,500 ± 120
Coating diameter (μm)	950 ± 50	1,200 ± 100	1,450 ± 100	1,700 ± 150
Minimum bending radius (mm)	90 ^{*1} ₋₅₀ ^{*2}	110 ^{*1} ₋₈₀ ^{*2}	150 ^{*1} ₋₁₀₀ ^{*2}	200 ^{*1} ₋₁₃₀ ^{*2}
Coating material	Silicone resin			
Lattice defect (%)	< 0.1			
Uncircularity (%)	< 5			
length/pc	Maximum length of 1pc : 10ft Cut and rough polish are available. Cut length of 1pc : Customer order			

Sumitomo imaging fibers

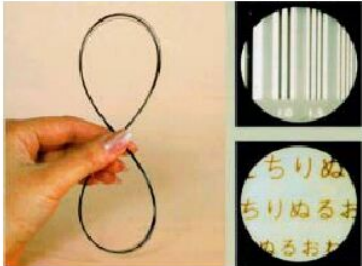

SEI

Product Lineup

TP03105B

	IGN-02/03	IGN-028/06	IGN-035/06	IGN-037/10	IGN-05/10	IGN-08/30	IGN-15/30	IGN-20/50
Number of picture elements	3,000	6,000	6,000	10,000	10,000	30,000	30,000	50,000
Jacketing diameter (um)	200	280	350	370	500	800	1,500	2,000
Picture elements area diameter (um)	180	252	315	333	450	720	1,350	1,800
Coating diameter (Primary) (um)	250	340	420	450	590	960	1,900	2,400
Coating diameter (Secondary) (um)	---	---	---	---	---	---	2,500	3,000
Circularity	>= 0.93							
Core material	GeO2 Containing Silica							
Cladding material	F Containing Silica						Pure Silica	
Coating material	Silicone						Silicone + PFA	
Numerical aperture	0.35						0.30	
Lattice defect (%)	<= 0.1							
Allowable bending radius (mm)	10	15	15	20	25	40	75	100
Allowable max temp. (C)	150							

Copyright © 2003 Sumitomo Electric Industries, LTD.
SEI Proprietary and Confidential.

SUMITOMO ELECTRIC

All have small imaging area
<2 mm diameter
Rad-hard?

>20 meter available

5 meter limit

IGN-08/20 - sample

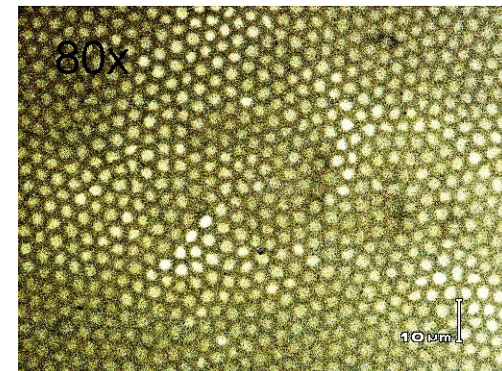
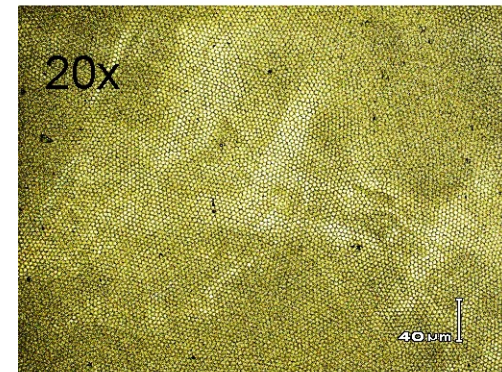
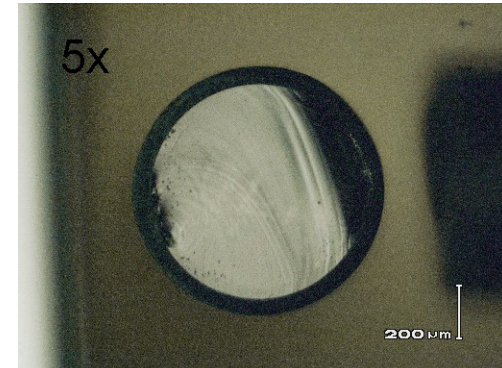

More imaging fibers (*glass*)

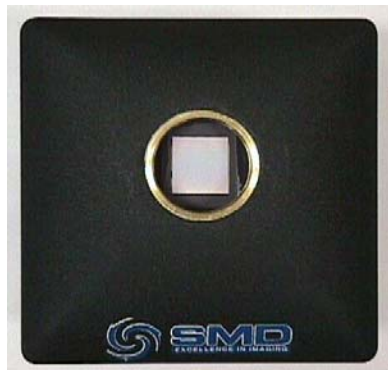

SMD camera

CCD size: 13.4 x 13.4 mm
Pixels: 960x960
Single frame: 240x240 pixels
57,600 picture elements
Reduced pixel size: 56 x 56 um

Hawkeye flexible borescope



18,000 glass fibers
fiber diameter 6 μm
bundle diameter ~ 1-mm
8-mm outer diameter
FOV 40 deg
DOF 15-mm to infinity
Length: 1-meter

total fiber counts ~18,000 in 1 mm diameter
Imaging ~150 x 150 fibers on 240 x 240 CCD array
~1 imaging fiber on ~1.6 pixel on a single frame

borescope retroreflected illumination

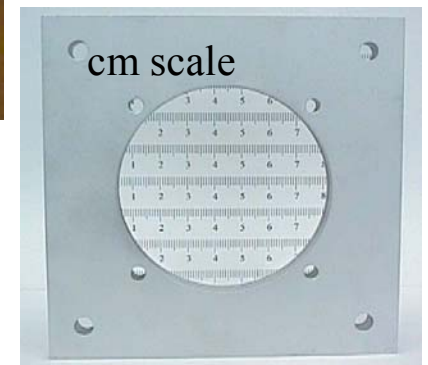
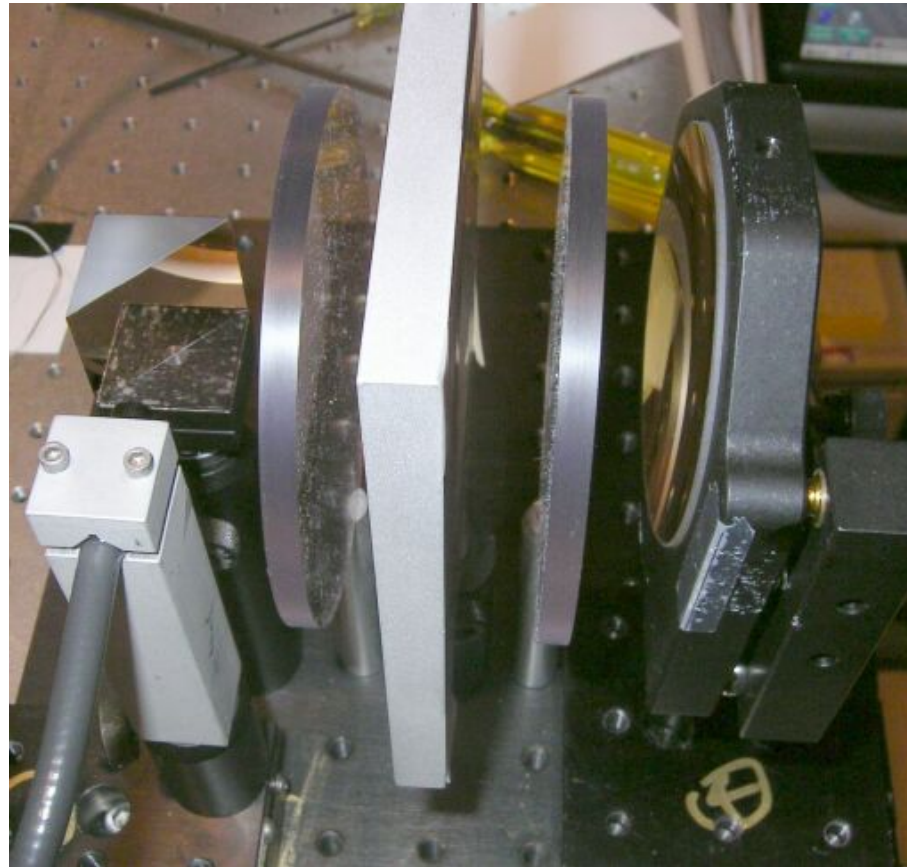
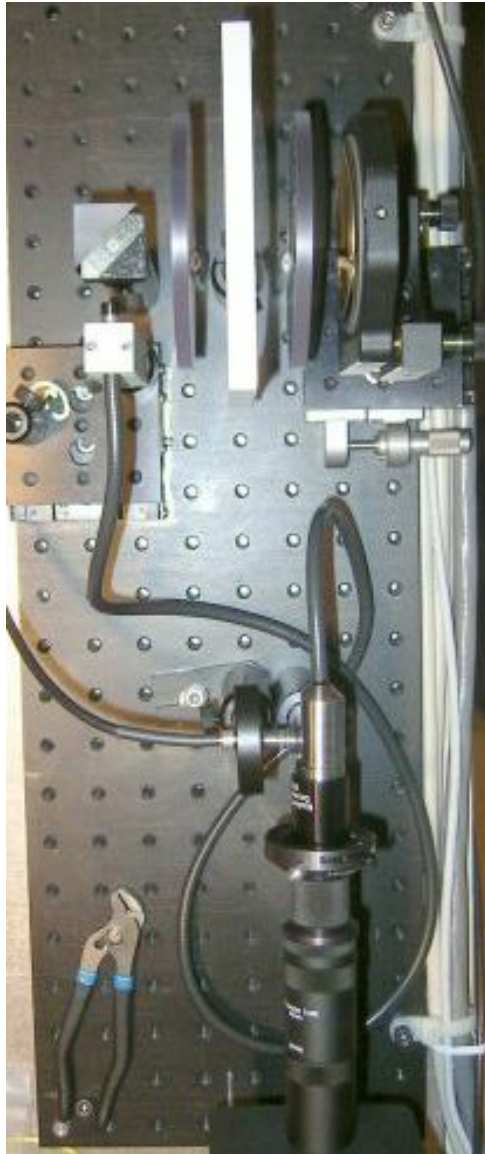

laser borescope retroreflected illumination

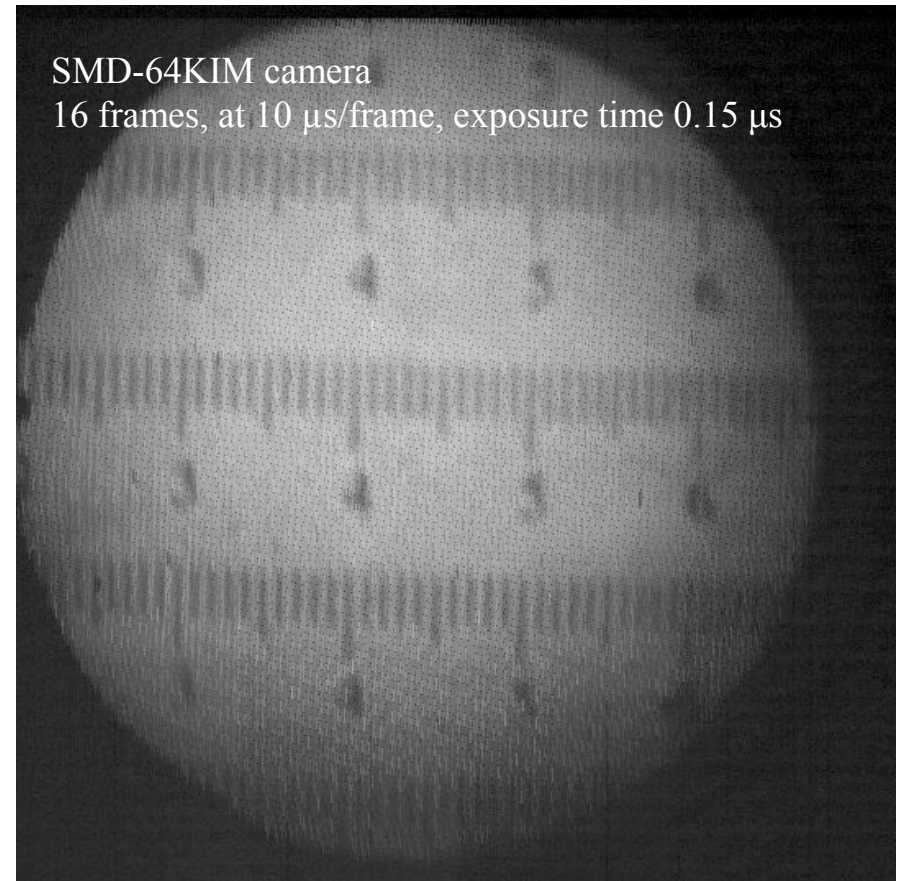
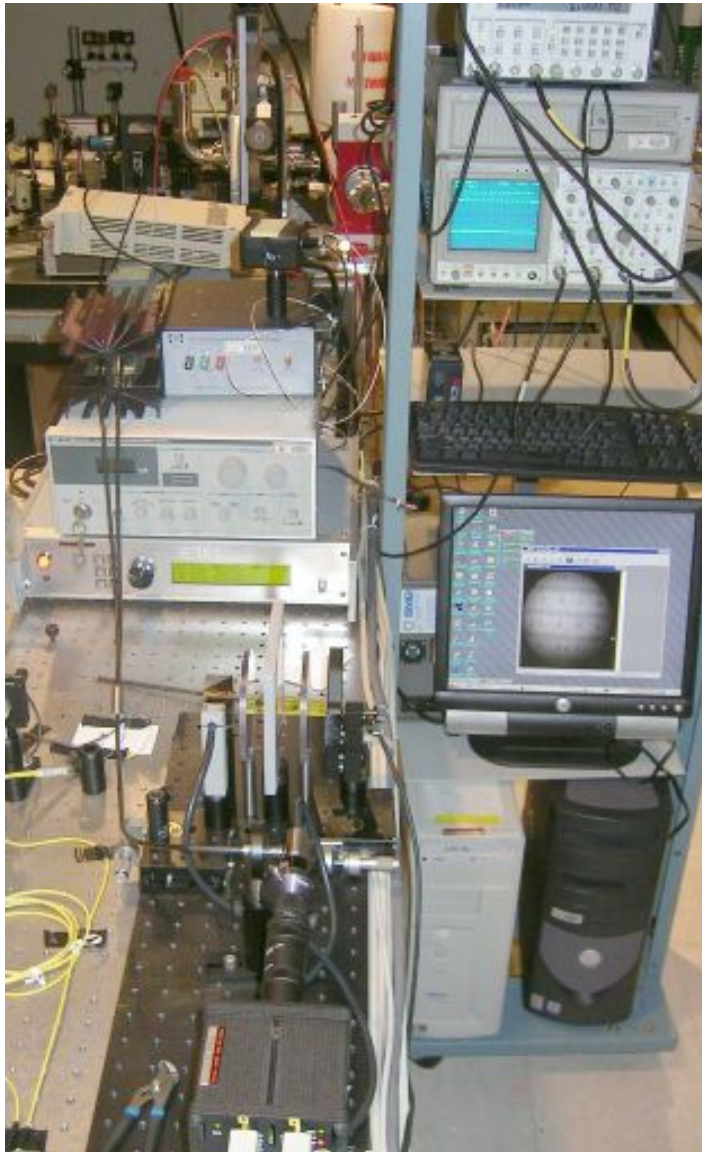

SMD-64KIM camera
16 frames, at 10 μs /frame, exposure time 0.15 μs

total fiber counts $\sim 18,000$ in 1 mm diameter
Imaging $\phi=150$ fibers on 240 x 240 CCD array
 ~ 1 imaging fiber on ~ 1.6 pixel on a single frame

image quality comparison

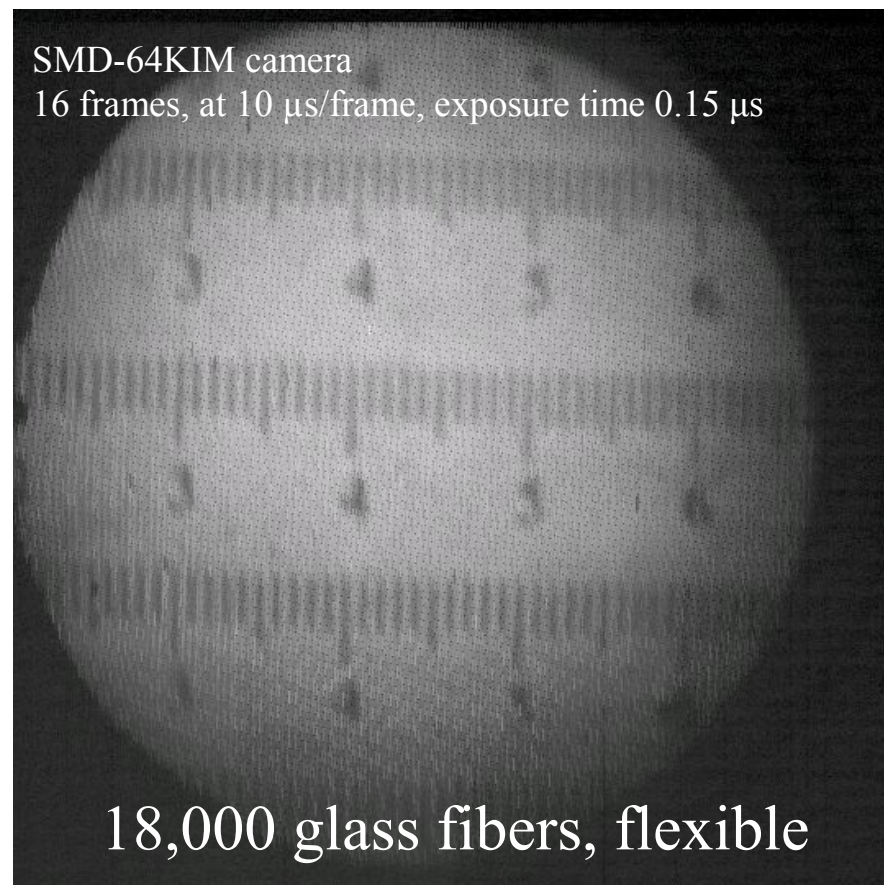
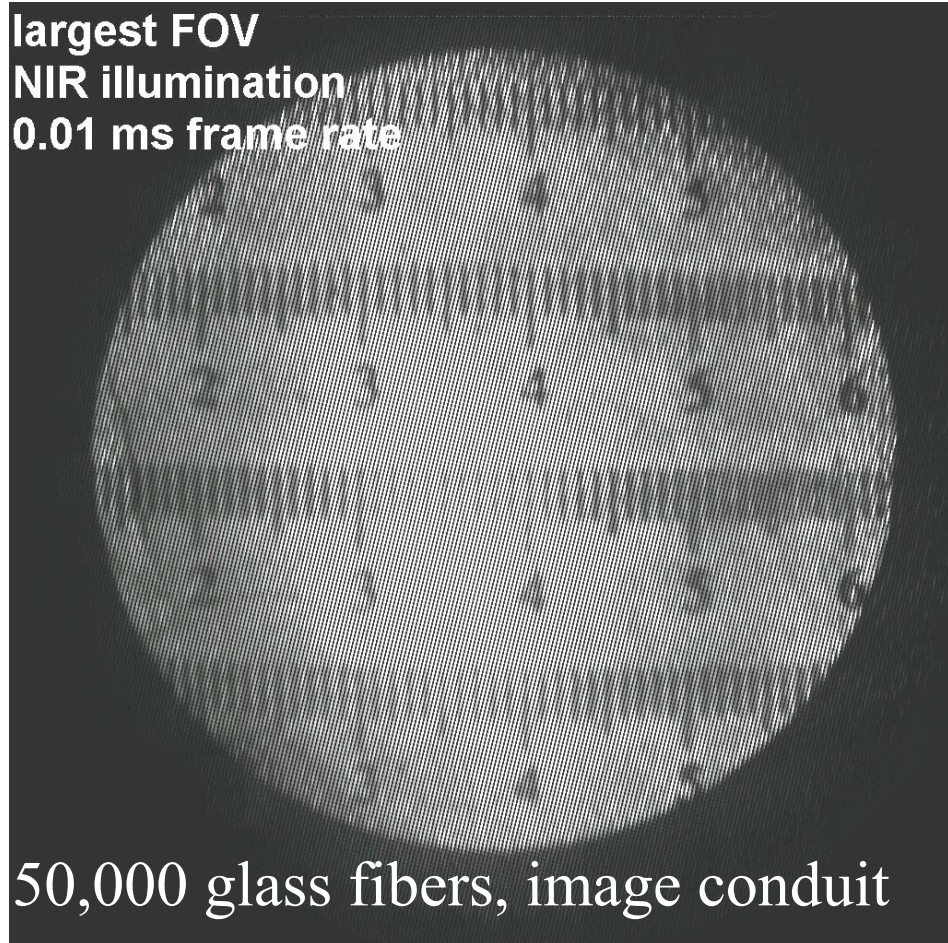

rad-hard Sumitomo 30,000 fibers image ??



Optical Diagnostics

An optical chopper in motion @ 4 kHz

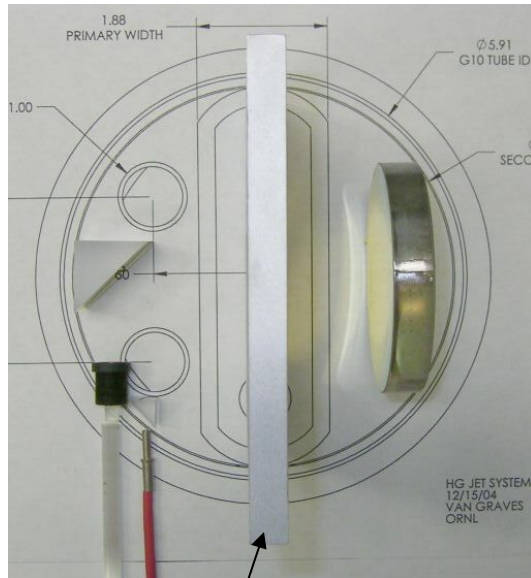

Velocity @ ~40 m/s

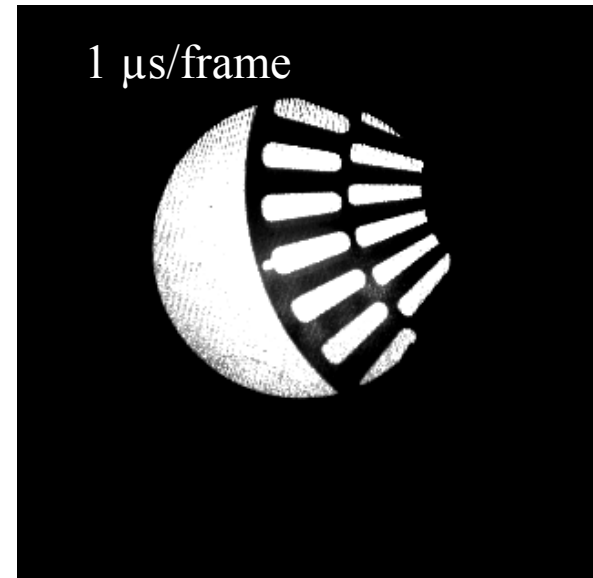
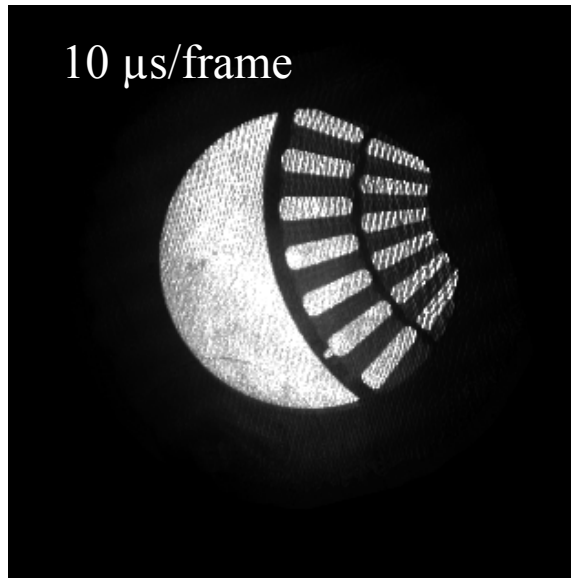
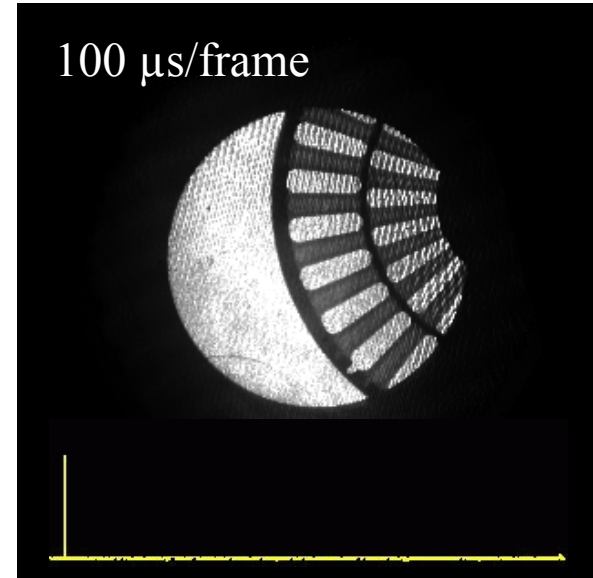
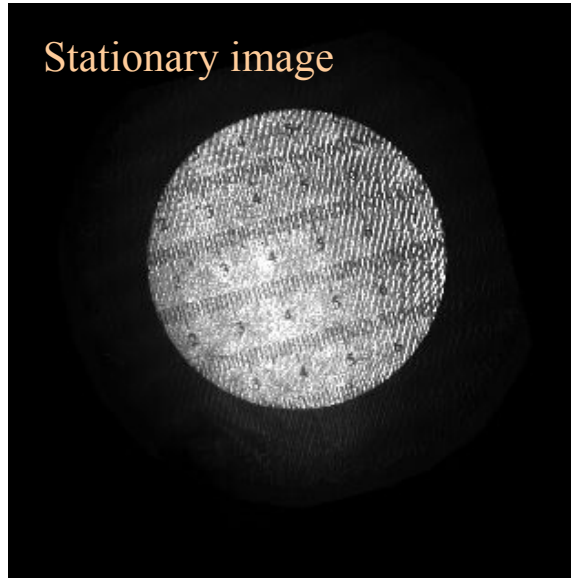

Irradiation Studies of Optical Components - II

CERN, week of Oct. 24, 2005

1.4 GeV proton beam

4×10^{15} proton

Irradiation dose: equivalent to
40 pulses of 24 GeV proton beam

28 TP/pulse

total of 1.2×10^{15} proton

total fiber counts ~30,000 in 0.72 mm diameter
imaging $\phi=195$ fibers on 240 x 240 CCD array
~1 imaging fiber on ~1.2 pixel on a single frame

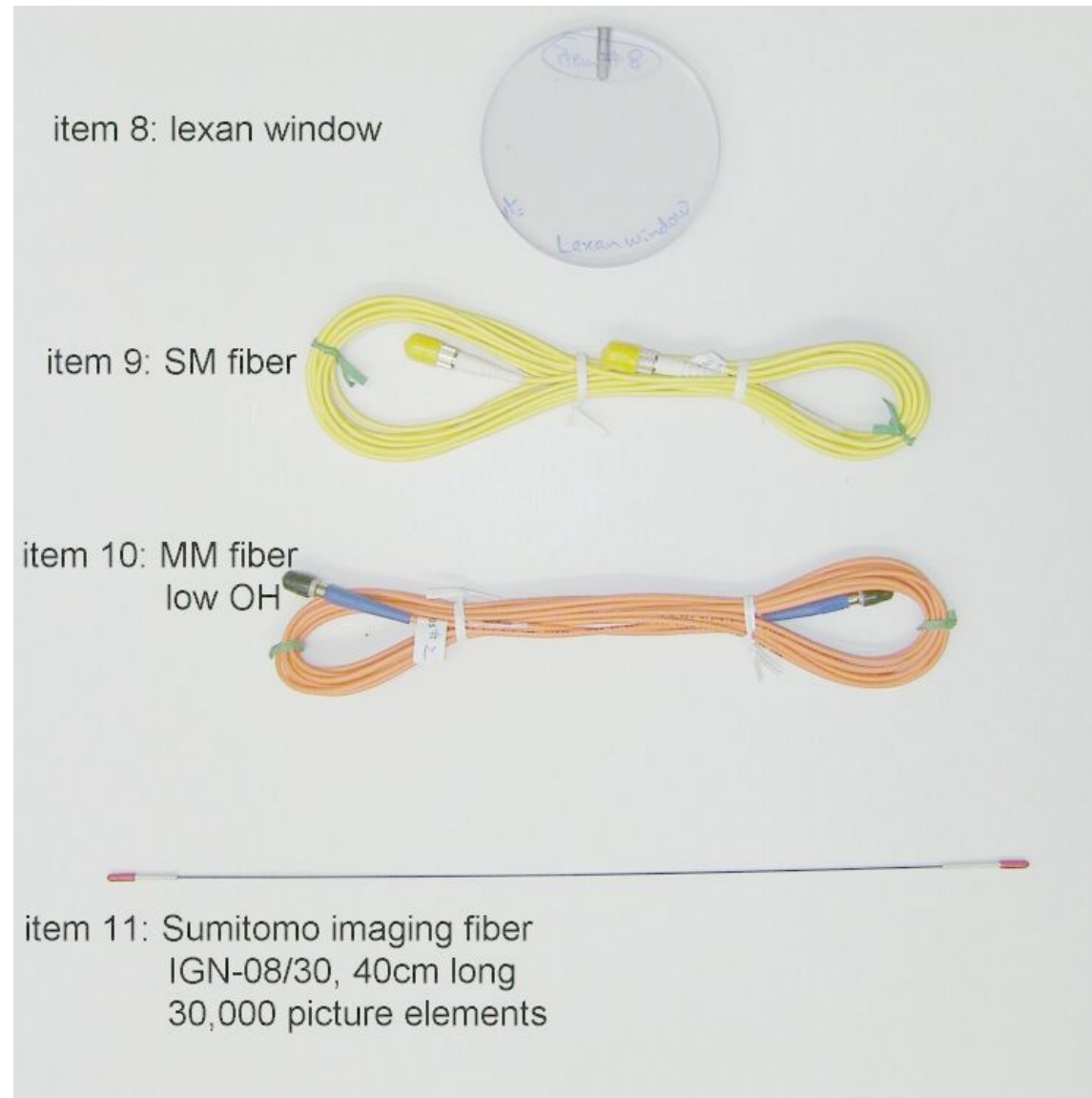

One set of optics per viewport

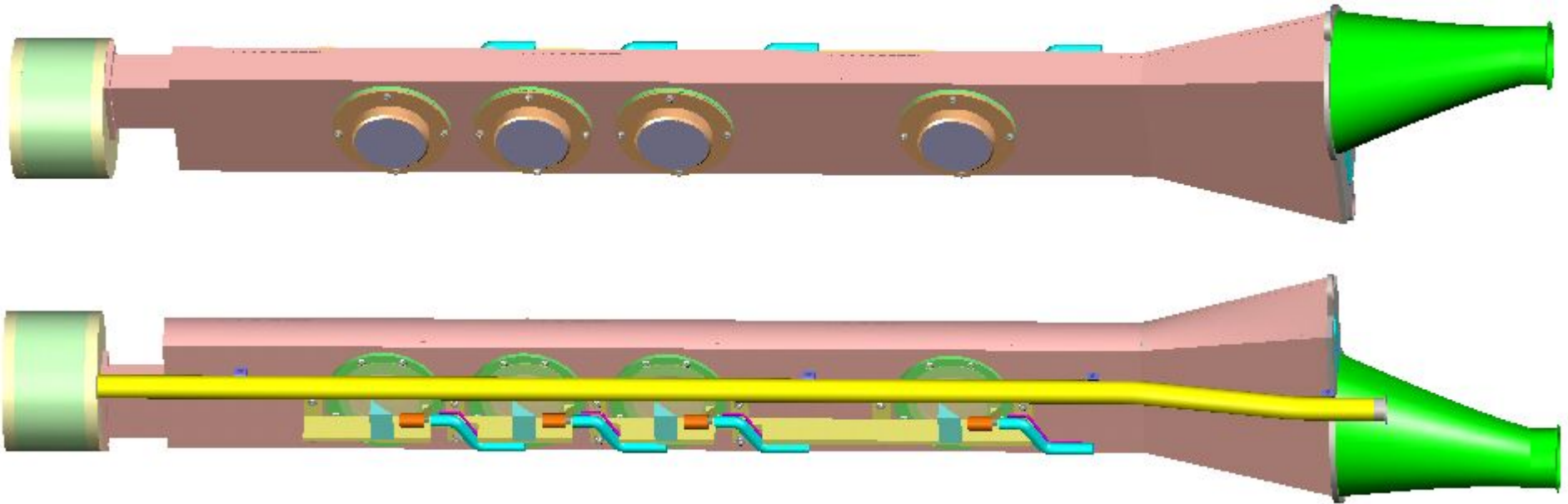

- tight environment
- high radiation area
- non-serviceable area
- passive components
- optics only, no active electronics
- transmit image through flexible fiber bundle

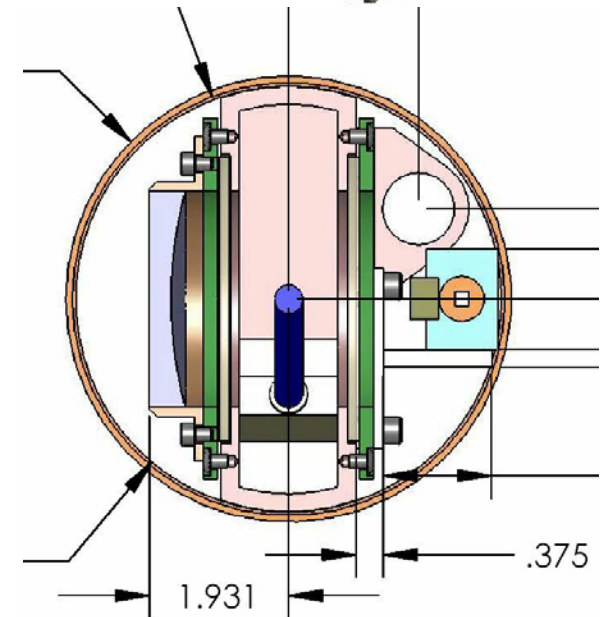



BDL20-808-F6

s/n: 05091745

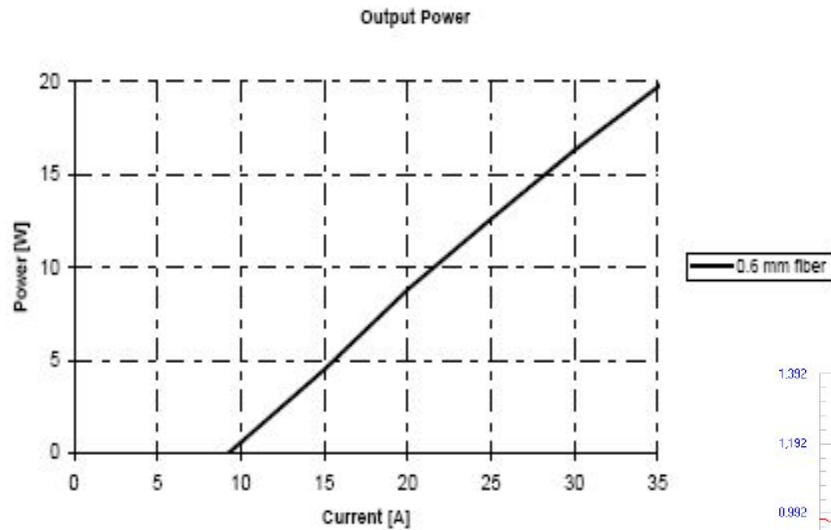

Parameter	Value	Unit
Temperature	25	°C
Rated power	20	W
Current at rated power	35.38	A
Maximum current	41.63	A
Threshold current	9.2	A
Center wavelength	808.6	nm
Linewidth FWHM	2.64	nm

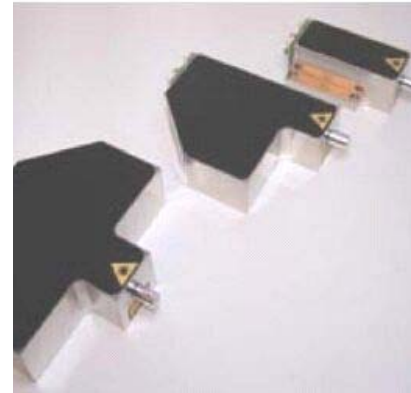

RPMC Lasers, Inc.
 203 Joseph Street
 O'Fallon, Missouri 63366 USA
 (636) 272-7227
 (636) 272-3909 (Fax)
www.rpmclasers.com

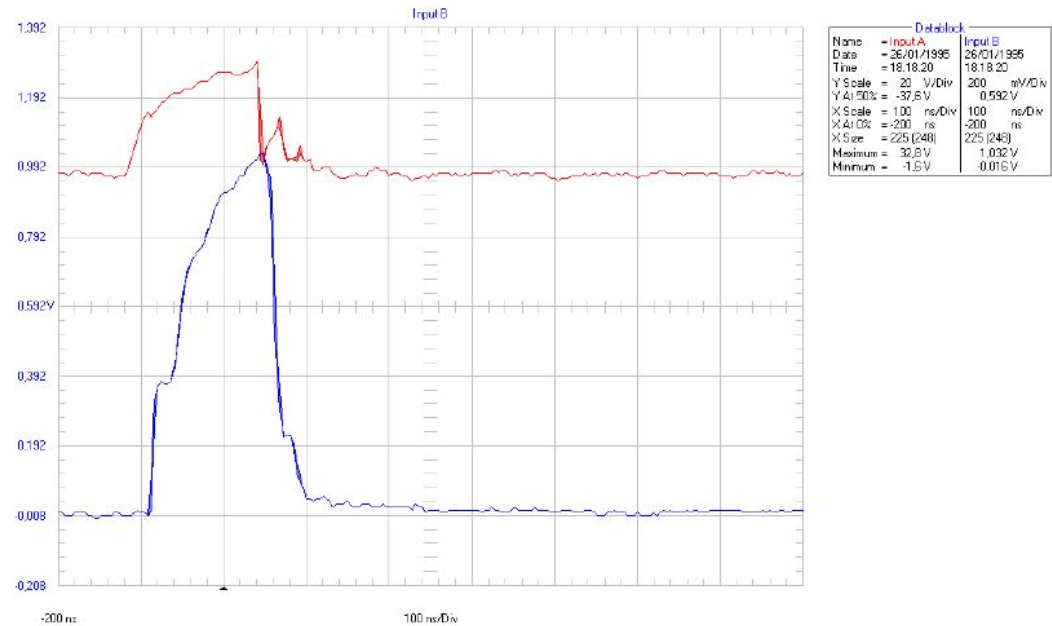

Input A: Current 20 A/div
 Input B: Optical Power 4 W/div

Fast camera capture of waterjet September 16, 2005 @ Princeton

Camera: FastVision 13 capability
1280x1024 pixels, 500 frames/sec, 0.5 sec video
or ...



nozzle: diameter ~8 mm, length 6-inch

waterjet in action: movie

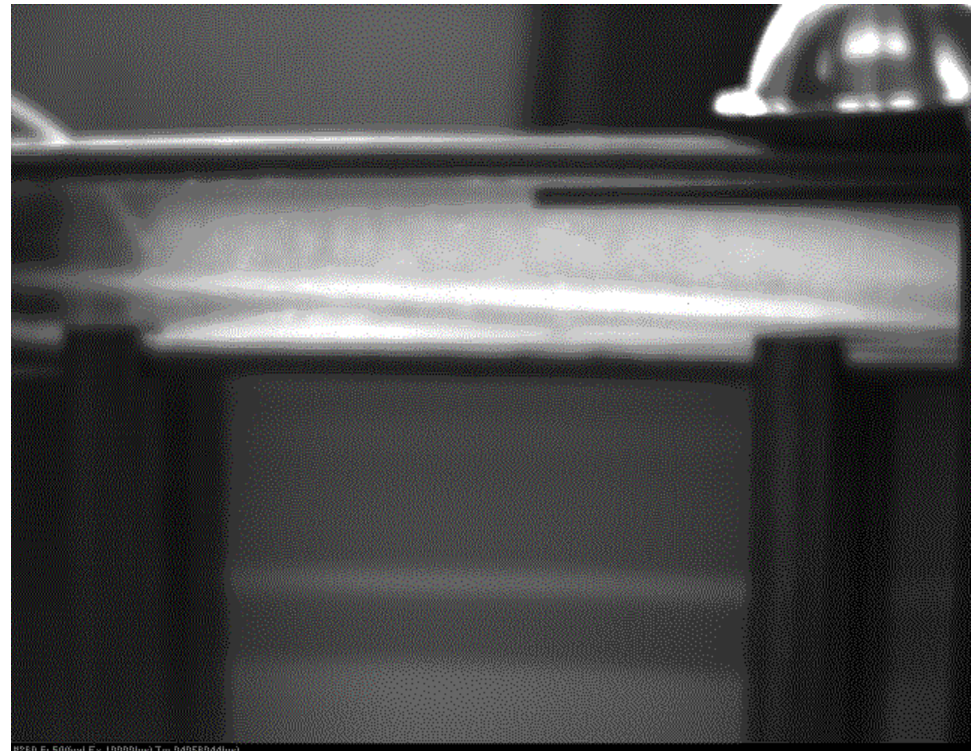

1280x1000 pixels
50 frame/sec
20 frames of video

Water jet velocity measurement using strobe light

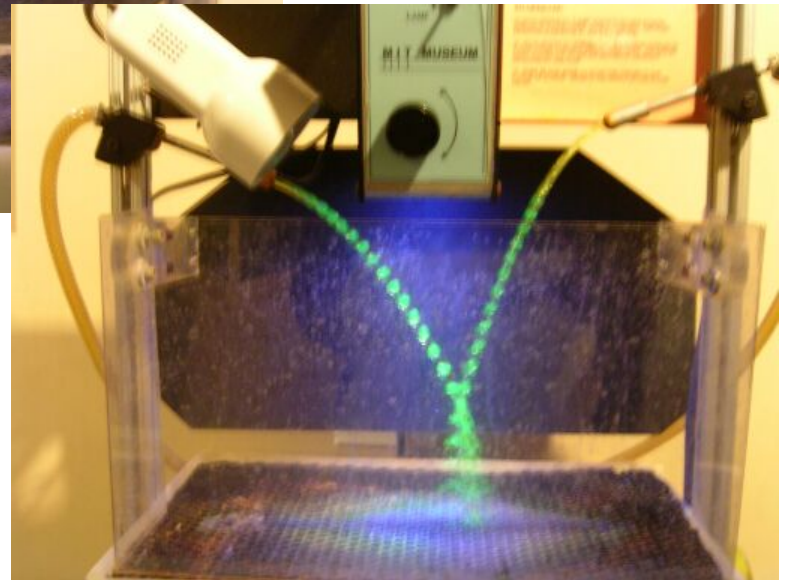
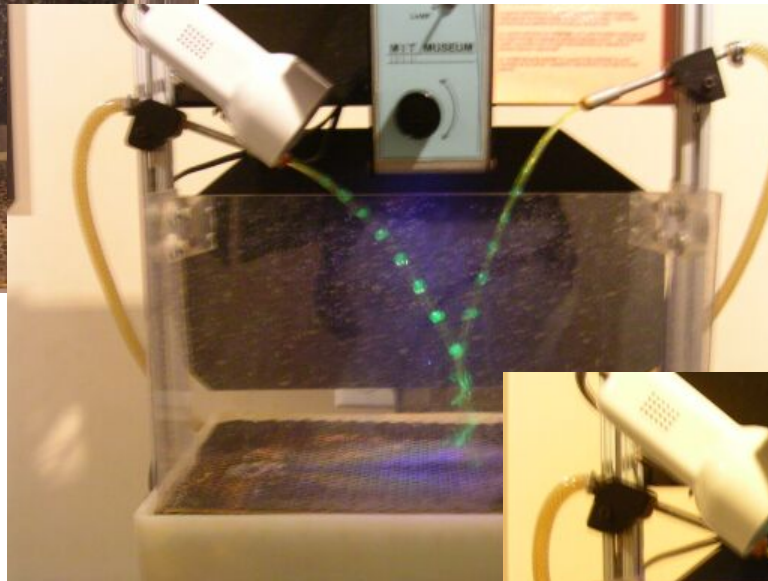
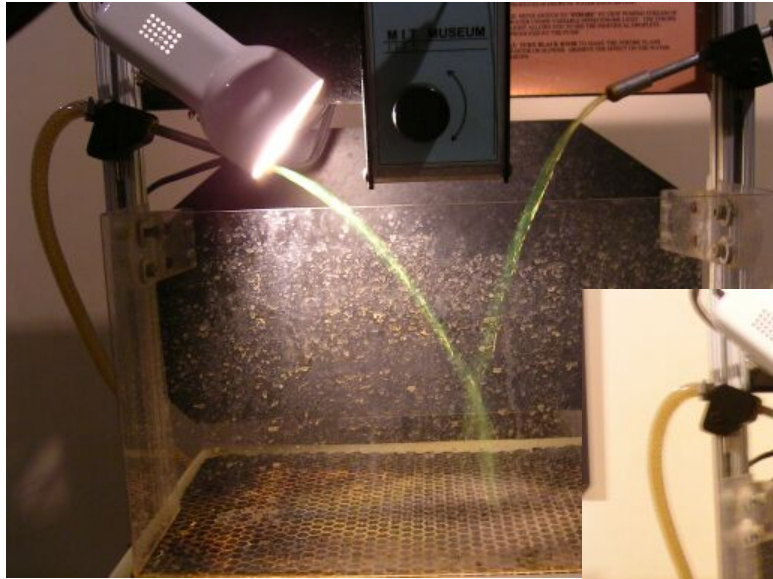

flow velocity = strobe frequency $\times \Delta d$

MIT museum - Harold Edgerton