

- NOTES
1. MATERIAL CERTIFICATIONS REQUIRED.
 2. WELDING AND INSPECTION SHALL BE PERFORMED IN ACCORDANCE WITH ASME SECTION IX OR OTHER APPROVED STANDARD. NO CODE STAMP REQUIRED.
 3. 100% RADIOGRAPHY INSPECTION REQUIRED.
 4. ASSEMBLY SHALL BE ANODIZED PER AEROSPACE MATERIAL SPECIFICATION 2487 "ANODIC TREATMENT OF TITANIUM AND TITANIUM ALLOYS".
 5. DESIGN PRESSURE 1500 PSI. ASSEMBLY SHALL BE PRESSURE TESTED WITH WATER TO 2250 PSI.

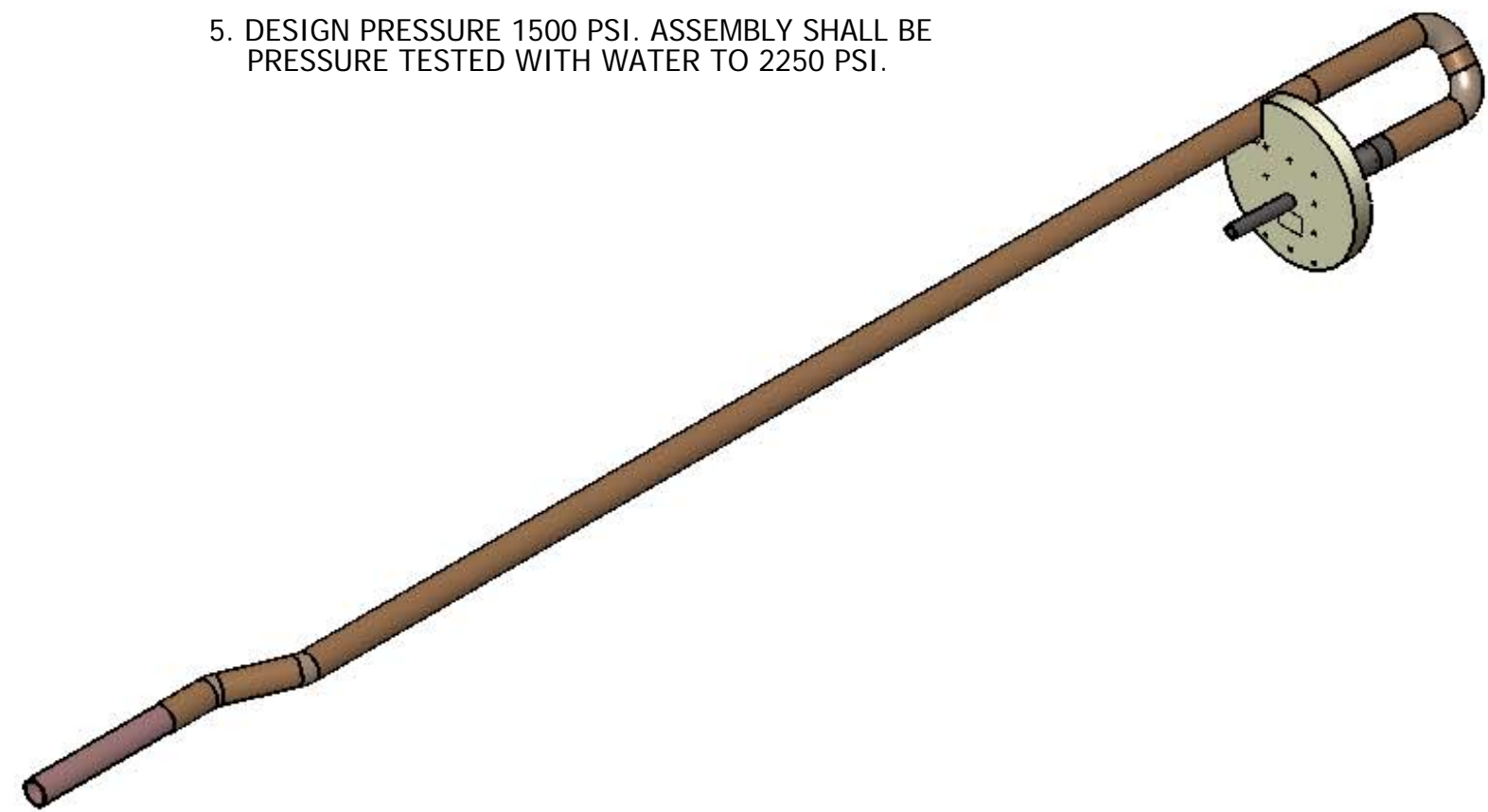
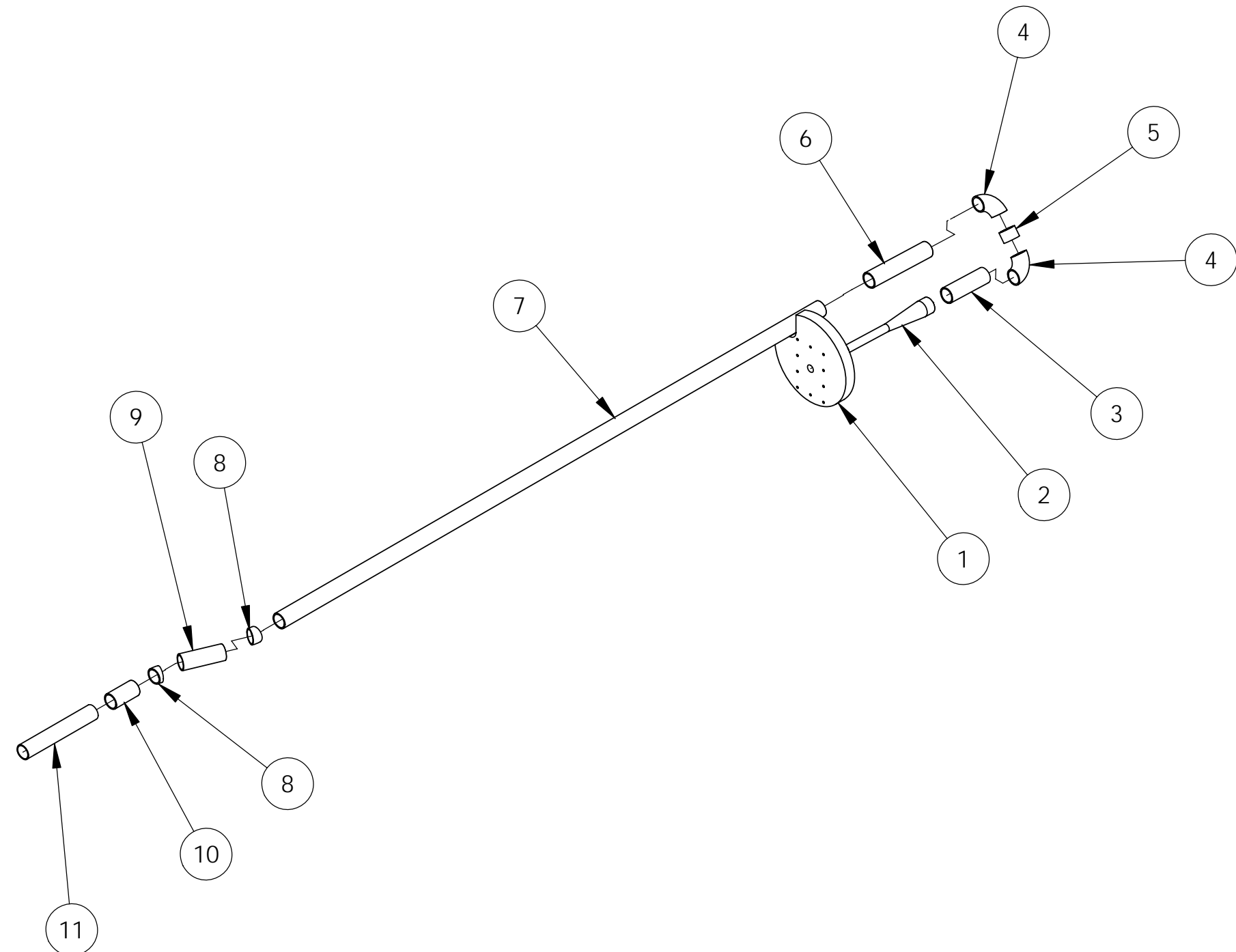

ITEM	NAME	MATERIAL	DESCRIPTION	DWG	test/QTY.
11	HG SUPPLY INLET TUBE	TI GRADE 2, ASTM B-861	RIGID SEAMLESS TUBE, 1.000 X .065 WALL X 3.500	N/A	1
10	HG SUPPLY TI PIPING	TI GRADE 2, ASTM B-861	RIGID SEAMLESS PIPE, 3/4" SCH10, 2.000 L	N/A	1
9	HG SUPPLY TI PIPING	TI GRADE 2, ASTM B-861	RIGID SEAMLESS PIPE, 3/4" SCH10, 2.819 L	N/A	1
8	HG SUPPLY TI ELBOW	TI GRADE 2, ASTM B-861	RIGID SEAMLESS ELBOW, 3/4" SCH10	N/A	2
7	HG SUPPLY TI PIPING	TI GRADE 2, ASTM B-861	RIGID SEAMLESS PIPE, 3/4" SCH10, 46.700 L	203-HJT-0629	1
6	HG SUPPLY TI PIPING	TI GRADE 2, ASTM B-861	RIGID SEAMLESS PIPE, 3/4" SCH10, 5.000 L	203-HJT-0628	1
5	HG SUPPLY TI PIPING	TI GRADE 2, ASTM B-861	RIGID SEAMLESS PIPE, 3/4" SCH10, .700 L	N/A	1
4	HG SUPPLY TI ELBOW	TI GRADE 2, ASTM B-861	RIGID SEAMLESS ELBOW, 3/4" SCH10	N/A	2
3	HG SUPPLY TI PIPING	TI GRADE 2, ASTM B-861	RIGID SEAMLESS PIPE, 3/4" SCH10, 3.250 L	N/A	1
2	HG SUPPLY REDUCER NOZZLE	TI-6AL-4V, ASTM B-265	FLOW REDUCER AND NOZZLE	203-HJT-0627	1
1	HG NOZZLE FLANGE STRAIGHT	TI-6AL-4V, ASTM B-265	NOZZLE FLANGE	203-HJT-0626	1

<p>THIRD-ANGLE PROJECTION</p> <p>UNLESS OTHERWISE NOTED</p> <ol style="list-style-type: none"> 1. ALL DIMENSIONS ARE IN INCHES 2. INTERPRET DIMENSIONS AND TOLERANCES PER ASME Y14.5M 3. MACHINED FINISH 125 MICRO-INCHES RMS 4. CONCENTRICITY .010 TIR 5. MACHINED ANGLES ±1/2° FORMED ANGLES ±1° 6. BREAK SHARP CORNERS AND REMOVE ALL BURRS 7. WHOLE NUMBERS AND FRACTIONS ±1/16 8. X DECIMALS ±.030 9. XX DECIMALS ±.010 10. XXX DECIMALS ±.005 	<p>This drawing was prepared by ORNL solely for use in work performed under Department of Energy contract number DE-AC05-00OR22725 and applicable Work for Others Agreements and Cooperative Research and Development Agreements. This drawing is property of ORNL and must be returned upon request.</p>		<p>OAK RIDGE NATIONAL LABORATORY operated for the U.S. Department of Energy under contract DE-AC05-00OR22725 Oak Ridge, TN</p>		
	<p>REMOTE SYSTEMS GROUP NUCLEAR SCIENCE & TECHNOLOGY DIVISION</p>		<p>MERIT EXPERIMENT PRIMARY TUBE ASSEMBLY HG STRAIGHT NOZZLE ASSY</p>		
<p>CAD FILE HG STRAIGHT NOZZLE ASSY</p>		<p>PREV ASSY 203-HJT-0610</p>		<p>SCALE 1:6</p>	<p>SHEET 1 of 2</p>
<p>SIZE C</p>		<p>DWG NO. 203-HJT-0625</p>		<p>REV 0</p>	
<p>DRAWING APPROVALS</p>		<p>DATE</p>			

REV	DESCRIPTION	DATE	BY	APPROVED
0	ORIGINAL ISSUE	12/14/2006	VBG	VBG

- NOTES
1. MATERIAL CERTIFICATIONS REQUIRED.
 2. WELDING AND INSPECTION SHALL BE PERFORMED IN ACCORDANCE WITH ASME SECTION IX OR OTHER APPROVED STANDARD. NO CODE STAMP REQUIRED.
 3. 100% RADIOGRAPHY INSPECTION REQUIRED.
 4. ASSEMBLY SHALL BE ANODIZED PER AEROSPACE MATERIAL SPECIFICATION 2487 "ANODIC TREATMENT OF TITANIUM AND TITANIUM ALLOYS".
 5. DESIGN PRESSURE 1500 PSI. ASSEMBLY SHALL BE PRESSURE TESTED WITH WATER TO 2250 PSI.

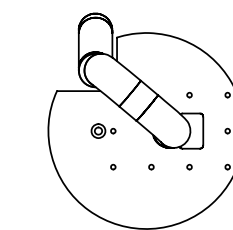
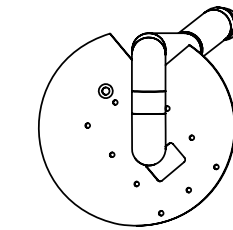
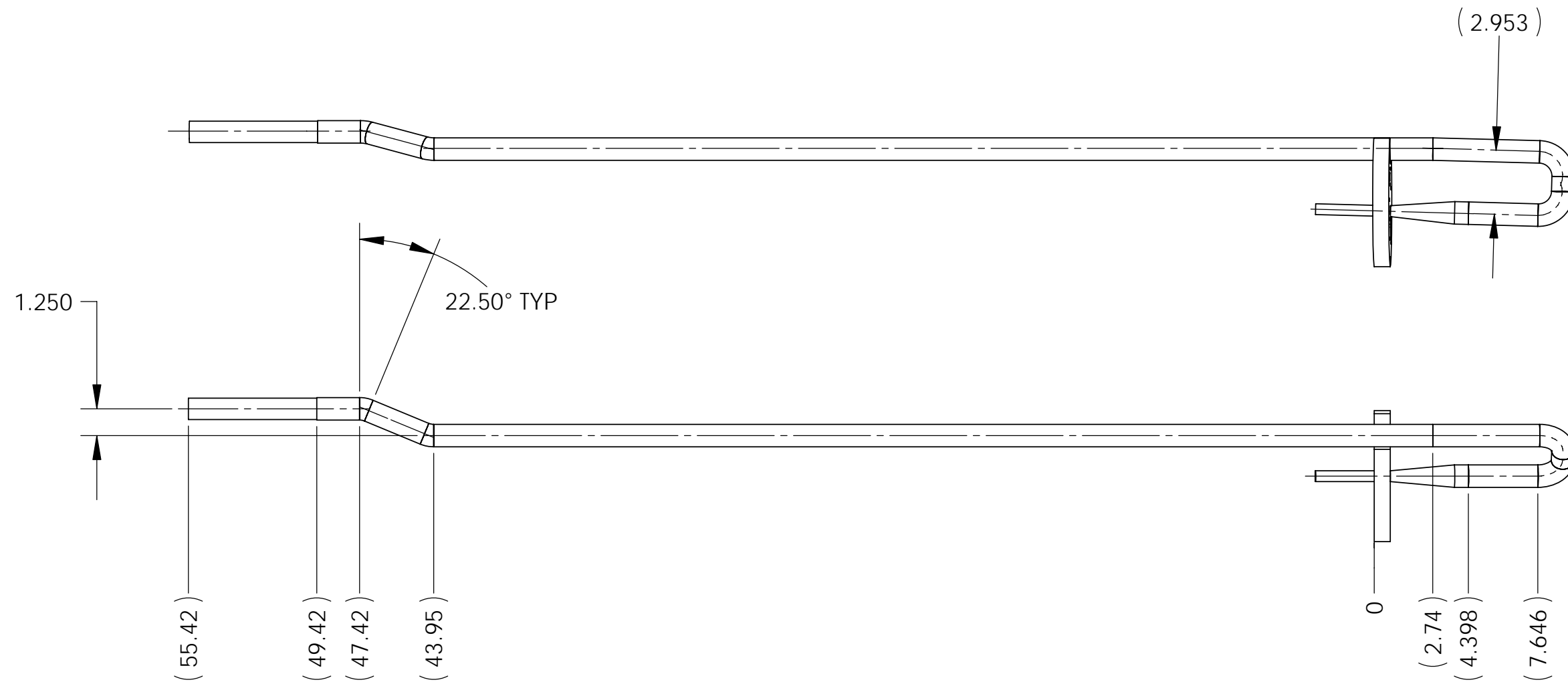

ORIENTATION OF PIPES PRIOR TO WELDING IS CRITICAL

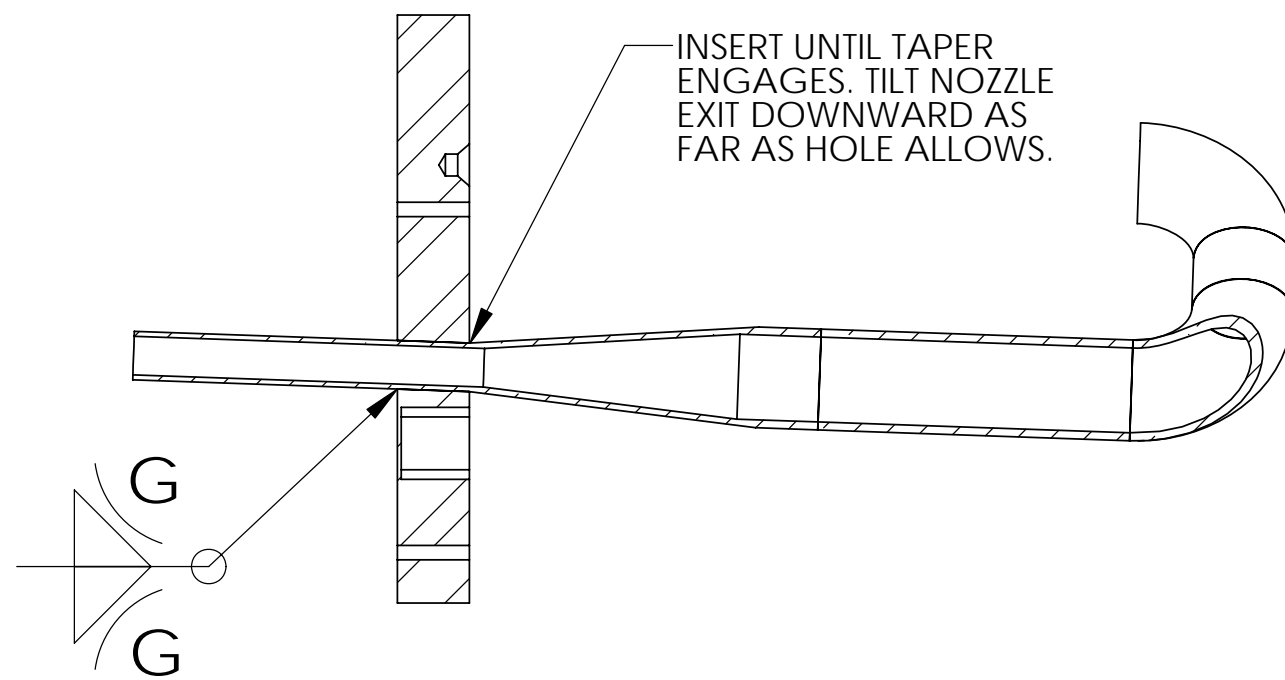
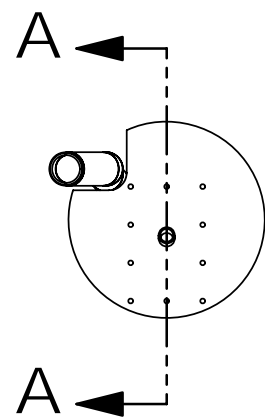
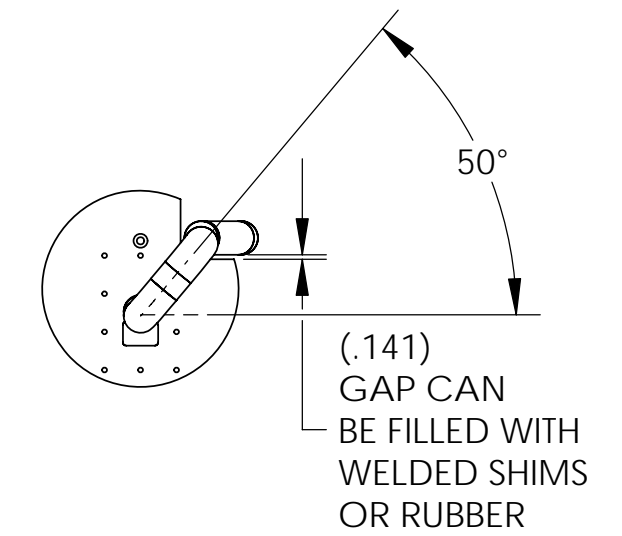
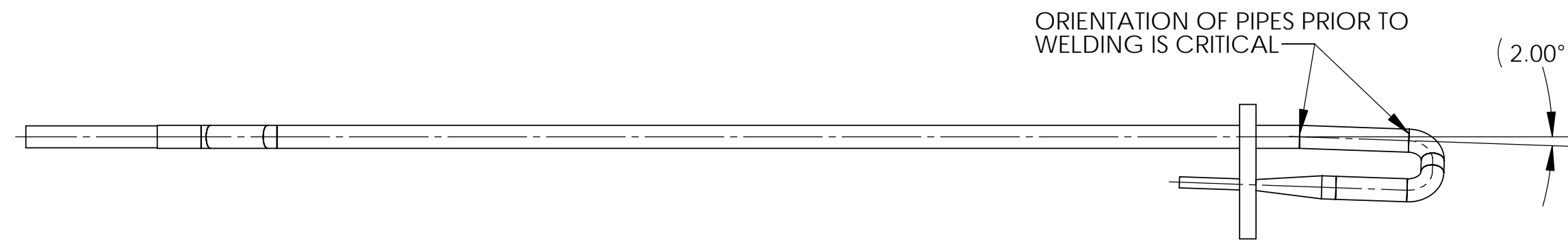

SECTION A-A
SCALE 1 : 2

<p>THIRD-ANGLE PROJECTION</p>	This drawing was prepared by ORNL solely for use in work performed under Department of Energy contract number DE-AC05-00OR22725 and applicable Work for Others Agreements and Cooperative Research and Development Agreements. This drawing is property of ORNL and must be returned upon request.			<p>OAK RIDGE NATIONAL LABORATORY operated for the U.S. Department of Energy under contract DE-AC05-00OR22725 Oak Ridge, TN</p>		
	UNLESS OTHERWISE NOTED 1. ALL DIMENSIONS ARE IN INCHES 2. INTERPRET DIMENSIONS AND TOLERANCES PER ASME Y14.5M 3. MACHINED FINISH 125 MICRO-INCHES RMS 4. CONCENTRICITY .010 TIR 5. MACHINED ANGLES ±1/2° 6. FORMED ANGLES ±1° 7. BREAK SHARP CORNERS AND REMOVE ALL BURRS 8. X DECIMALS ±.030 9. XX DECIMALS ±.010 10. XXX DECIMALS ±.005			<p>REMOTE SYSTEMS GROUP NUCLEAR SCIENCE & TECHNOLOGY DIVISION</p>		
DES	V GRAVES	12/08/2006	<p align="center">MERIT EXPERIMENT PRIMARY TUBE ASSEMBLY HG STRAIGHT NOZZLE ASSY</p>			
DRW	V GRAVES	12/08/2006				
CHK	W SANDS	12/12/2006				
ENG	V GRAVES	12/08/2006				
QA			CAD FILE HG STRAIGHT NOZZLE ASSY	PREV ASSY 203-HJT-0610	SCALE 1:6	SHEET 2 of 2
DRAWING APPROVALS		DATE	SIZE C	DWG NO. 203-HJT-0625	REV 0	