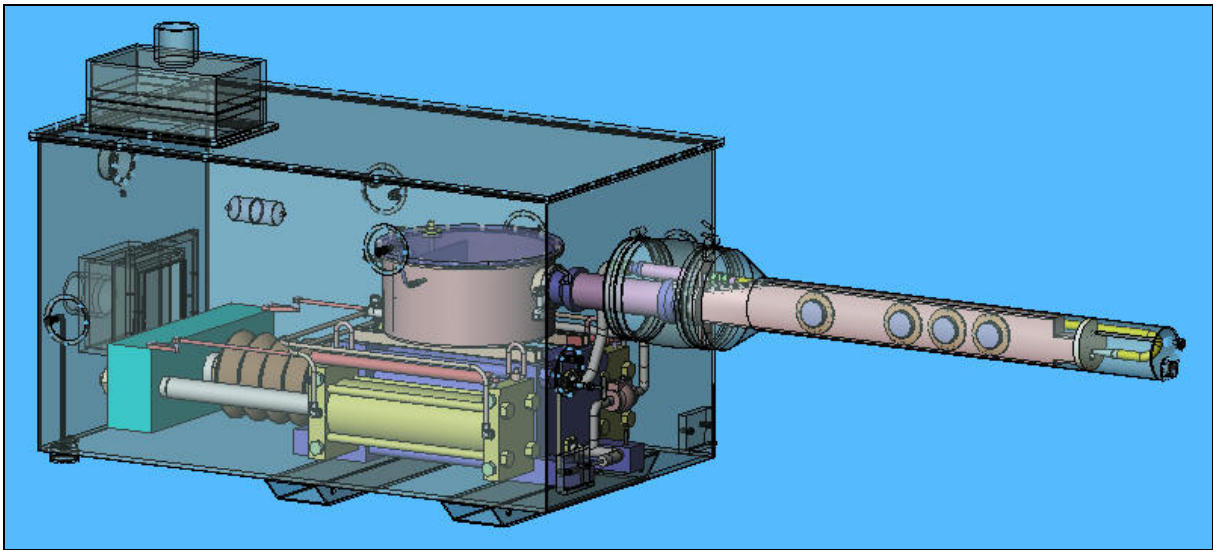




**Report No. 203-HJT-9010 Rev. 0**

# **Design, Operations, and Safety Report for the MERIT Target System**



**Van B. Graves  
Philip T. Spampinato**

**June 2006**

## **Design, Operations, and Safety Report for the MERIT Target System**

Van B. Graves

Philip T. Spampinato

### DISCLAIMER

This report was prepared as an account of work sponsored by an agency of the United States Government. Neither the United States government nor any agency thereof, nor any of their employees, makes any warranty, express or implied, or assumes any legal liability or responsibility for the accuracy, completeness, or usefulness of any information, apparatus, product, or process disclosed, or represents that its use would not infringe privately owned rights. Reference herein to any specific commercial product, process, or service by trade name, trademark, manufacturer, or otherwise, does not necessarily constitute or imply its endorsement, recommendation, or favoring by the United States Government or any agency thereof. The views and opinions of authors expressed herein do not necessarily state or reflect those of the United States Government or any agency thereof.

Oak Ridge National Laboratory is managed by UT-Battelle, LLC, under contract DE-AC05-00OR22725 for the U.S. Department of Energy.

## Table of Contents

Executive Summary.....	1
1.0 Introduction .....	2
1.1 Background.....	2
1.2 Design Overview .....	2
1.3 Material Compatibility .....	2
2.0 Design Specifications and Requirements .....	4
2.1 Design Specification - ISO 2919.....	4
2.2 Geometry .....	5
2.3 Operating Temperature.....	7
2.4 Mercury Containment Boundaries .....	7
2.5 Windows.....	9
2.6 Alignment .....	12
2.7 Assembly and Shipping.....	12
2.8 Component Size and Weight .....	12
2.9 Instrumentation.....	13
2.10 Stray Magnetic Fields.....	14
2.11 Radioactivation of Components .....	15
3.0 Component Design and Analysis .....	17
3.1 Flow Analysis.....	17
3.2 Syringe Pump System.....	18
3.3 Primary Containment.....	22
3.4 Secondary Containment.....	26
3.5 Baseplate Support Structures.....	28
3.6 Control System .....	36
4.0 Operations and Testing.....	39
4.1 Filling and Draining Mercury.....	39
4.2 Mercury Vapor Filtration .....	41
4.3 Off-Normal Conditions .....	43
4.4 Equipment for Mercury Handling .....	45
4.5 Equipment Maintenance .....	46
5.0 Facility Interfaces .....	47
5.1 Electrical.....	47
5.2 Ethernet.....	47
5.3 Target Equipment Installation .....	47
6.0 Packing and Transportation.....	49
7.0 Equipment Decommissioning and Disposition .....	50
8.0 References .....	51
Appendix A. Flow Analysis Documents .....	A-1
Appendix B. Syringe Pump Documents.....	B-1
Appendix C. Primary Containment Documents.....	C-1
Appendix D. Secondary Containment Documents.....	D-1
Appendix E. Base Support Structure Documents .....	E-1
Appendix F. Jerome <sup>®</sup> Vapor Monitor.....	F-1
Appendix G. Scavenger.....	G-1
Appendix H. Tiger-Vac <sup>®</sup> Vacuum Cleaner .....	H-1

Appendix I. Peristaltic Pump ..... I-1  
Appendix J. Material Safety Data Sheets..... J-1

## List of Figures

Figure 1. Hg target system within the secondary containment enclosure. ....	2
Figure 2. MERIT baseline geometry configuration. ....	6
Figure 3. Nozzle and solenoid relative to beam. ....	7
Figure 4. Target system primary containment.....	8
Figure 5. Target system containment boundary schematic. ....	8
Figure 6. Downstream beam window mounted to the secondary containment enclosure. ....	10
Figure 7. Laser diagnostic components, windows, and reflector; section cut taken at $Z = 0$ ..	10
Figure 8. Passive optical diagnostic components and support bracket. ....	11
Figure 9. Sapphire window mounted between elastomer gaskets.....	11
Figure 10. Diagnostic reflector assemblies. ....	11
Figure 11. Stray magnetic field plot around the solenoid and the target equipment.....	15
Figure 12. Magnitude of the field contours. ....	15
Figure 13. Fathom input model. ....	17
Figure 14. Fathom stagnation pressure output. ....	18
Figure 15. Syringe pump cylinders. ....	19
Figure 16. Hydraulic pump system. ....	20
Figure 17. Syringe HPU on-board controls.....	21
Figure 18. Primary containment. ....	22
Figure 19. Sump tank and piping. ....	23
Figure 20. Hg axial flow force analysis.....	25
Figure 21. Secondary containment left side. ....	26
Figure 22. Secondary containment right side.....	27
Figure 23. Solenoid and Hg system on common baseplate.....	28
Figure 24. Baseplate support structures design drawing. ....	29
Figure 25. Common baseplate and support beam. ....	30
Figure 26. Induced stresses of baseplate on three rollers. ....	31
Figure 27. Safety factor distribution for outer baseplate channel on three rollers. ....	32
Figure 28. Safety factor distribution for the jacking bracket weldment.....	33
Figure 29. Target cart and supporting transporter. ....	34
Figure 30. Safety factor distribution for the cart structure. ....	35
Figure 31. Safety factor distribution for solenoid support beam.....	36
Figure 32. MERIT layout in the CERN tunnels. ....	37
Figure 33. Labview control system operator interface.....	38
Figure 34. Mercury fill port.....	39
Figure 35. Peristaltic pump for transferring mercury.....	40
Figure 36. Target equipment moving into TT2A. ....	48
Figure 37. Target equipment inserted into solenoid.....	48
Figure 38. Target equipment and solenoid inside a short sealand container.....	49

**List of Tables**

Table 1. Estimated Component Sizes and Weights..... 12  
Table 2. List of sensors for the target system..... 14  
Table 3. Radioactivity of Target System Components..... 16  
Table 4. Syringe Pump Performance Parameters. .... 21  
Table 5. Hg Supply Component Pressure Ratings. .... 24  
Table 6. Miscellaneous Experiment Support Equipment. .... 45

## Executive Summary

The Mercury Intense Target (MERIT) is a proof-of-principle experiment tentatively scheduled to operate at CERN in April, 2007. It employs a free-jet mercury target operating in a 15 Tesla magnetic field, interacting with a 24 GeV/c proton beam with proton intensity per pulse similar to a 4 MW target station: the integrated beam intensity on target is  $3 \times 10^{13}$  protons. A maximum of  $3 \times 10^{13}$  protons per pulse can be submitted, where this single pulse experiment is on a 30-minute repetition rate. The target is designed to operate with up to 23-liters of elemental mercury. The target system and the solenoid will be located in the TT2A tunnel, the hydraulic pump equipment will be located in the TT2 tunnel, and the remote control station for the target will be located in Building 272, which is a 10-minute walking distance. At the completion of testing and after an acceptable cool down period, the target equipment, the mercury, and the solenoid will be shipped back to Oak Ridge National Laboratory (ORNL).

The design of the target system addressed numerous safety issues to ensure that the operation of the equipment, initially at ORNL and Massachusetts Institute of Technology, will meet all criteria for safe, reliable operations at CERN. This document addresses the general safety for operating the target system and describes what design features were incorporated to meet the conditions for safe operation. In addition, radiation safety was addressed as it relates to operating the equipment and decommissioning the target system; fire safety was a consideration for choosing an acceptable hydraulic fluid to operate the syringe pump, and the distribution of the magnetic field around the solenoid was investigated to assess its impact on operations.

The components that make up the target system are heavy, weighing up to 2-tonnes, and require handling by qualified rigging experts. Each component was carefully designed to include provisions for nylon lifting-straps and hoist rings that will be pre-mounted to the equipment.

Finally, and perhaps most significantly, mercury handling was the most significant factor considered for developing the target system design. The same principles for handling mercury that were developed for the Spallation Neutron Source – Target Test Facility (TTF) at ORNL, were employed for MERIT. And the experience gained during six years of successfully operating the TTF and dealing with large quantities of mercury without any incidents will be brought to bear on this experiment.

## 1.0 Introduction

### 1.1 Background

The Mercury Intense Target (MERIT) is a proof-of-principle experiment for a high power production target proposed for a Neutrino Factory or a Muon Collider. Oak Ridge National Laboratory (ORNL) engineers have developed a design for a free-jet mercury (Hg) target that will interact with a 24-GeV proton beam inside a 15 Tesla solenoid. The experiment will be installed initially at the Massachusetts Institute of Technology (MIT) for integrated systems testing, and later in the TT2A tunnel at CERN during a one-month period in 2007 for tests with the proton beam.

### 1.2 Design Overview

The target system design consists of primary and secondary containment boundaries, the Hg delivery system and related piping, proton beam windows, a laser-optics diagnostic provided by Brookhaven National Laboratory (BNL), and a support structure that also interfaces with the solenoid. The system is designed to produce a 1-cm diameter free jet with a nozzle velocity of 20 m/sec, and a flow rate up to 95 liters per minute.

The primary function of the target system is to deliver the mercury jet in the form of a continuous stream, into the high field solenoid while simultaneously intersecting a high-energy (24-GeV) proton beam. The duration of the jet must be sufficient to overlap the 1-second duration of the peak field in the solenoid. The target system provides the means for discharging the Hg jet and collecting and recycling elemental mercury through a syringe pump system. The mercury delivery system is installed within a secondary containment boundary. Figure 1 is a CAD model of the MERIT system.

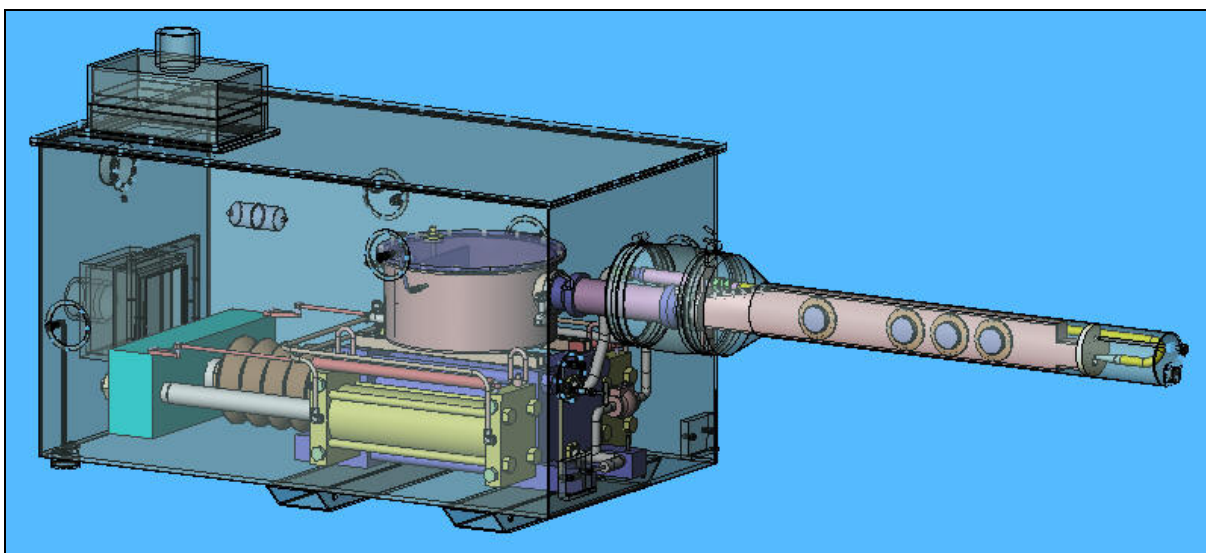


Figure 1. Hg target system within the secondary containment enclosure.

### 1.3 Material Compatibility

Two criteria were adopted for selecting materials for the design of the target system: 1) compatibility with elemental mercury (e.g., resistance to mercury-induced corrosion), and



2) transparency to magnetic fields (e.g., use of non-ferromagnetic materials). Elemental mercury dissolves metals such as copper that might normally be used for flange gaskets. Hence, any component or surface that could contact elemental mercury or its vapor is fabricated from materials that are relatively inert to mercury.

Non-magnetic material is used exclusively to avoid the forces that ferromagnetic materials experience in proximity to magnets. In addition, the gamma dose due to neutron activated materials in the target structure is estimated to be less than  $10^4$  rads, and all of the organic materials selected can easily withstand that level of radiation dose.

The following list summarizes the materials of construction for the MERIT system:

- austenitic stainless steel, type 316 or 304 – pump cylinders, piping, fittings and connectors, the storage tank,
- Nitronic 50 – tie rods for the cylinder assembly,
- buna-N elastomer – gasket material for removable cover seals,
- Ti6Al4V alloy, grade 5 for the proton beam windows, grade 2 for the piping and nozzle,
- sapphire – laser diagnostic windows,
- Lexan<sup>®</sup> – secondary enclosure cover and the sump tank cover, and
- 6061 aluminum alloy – base support structure.

Fasteners and miscellaneous items are non-magnetic wherever practical. Gaskets are non-reactive with mercury and capable of withstanding radiation doses of at least  $10^5$  rads.

## 2.0 Design Specifications and Requirements

The target system consists of four subsystems: 1) the primary containment structure, 2) the secondary containment structure, 3) a syringe pump system, and 4) the support base structure. The design for each subsystem takes into account the requirements for dealing with elemental mercury, a toxic heavy metal that will become mildly activated once beam tests commence, and the requirements for dealing with mildly radioactive structure at the completion of testing.

The system will operate within 1-atmosphere environments of air in both the primary and secondary containments. Air-activation, i.e.  $^{13}\text{N}$ ,  $^{15}\text{O}$  and  $^{41}\text{Ar}$ , will not be an issue for this system since the air environment is not purged after each pulse, and the containment boundaries remain intact for the duration of testing. If there is a need to breach either barrier after test operations commence, 1 hour of waiting will be sufficient for the decay of these isotopes. This approach is much simpler than incorporating equipment to evacuate and backfill with helium because of the complications of installing a mercury ventilation/filtration system.

The target system consists of the equipment to produce a mercury jet for a duration of up to 12 seconds. For a 12 second jet, a volume of 23 liters of mercury is required. Testing at ORNL and MIT will determine the minimum time required to develop a steady state Hg jet, and hence, the minimum quantity of mercury needed for beam tests at CERN. Minimizing the amount of activated liquid Hg is an operational consideration and goal.

The equipment is designed so that the elemental mercury in the target equipment is double-contained and mounted on a base structure that supports the target equipment and the solenoid system as an integrated unit. The support structure can be manually driven (pushed on Hilman<sup>®</sup> rollers) into or out of the axis of the proton beam line, and it has provisions to adjust the elevation and pitch of the integrated system.

The target system will be assembled initially with unlimited “hands on” access but must be maintained and operated with minimal personal contact after beam operations commence. Therefore, design of the target system has taken into account the eventual disassembly and handling of the equipment for shipment back to ORNL. The design features incorporated into the target system considered handling mildly activated components that are mercury-contaminated, as well as handling activated mercury in order to minimize exposure to personnel.

### 2.1 Design Specification - ISO 2919

Design of the target system used the criteria of ISO 2919, Table 2 “Classification of Sealed Source Performance,” Class 2, as a starting point. This requirement was suggested early in the project by the CERN Safety Commission, and was considered to be the minimum requirement needed to start the design of MERIT. Furthermore, it was established that these requirements could be met by analysis or engineering judgement, in lieu of performance tests.

*ISO 2919, Table 2, Class 2*

**Temperature** -40° C (20 minutes), +80° C (1 hour) [-40° F and +176° F]

*All of the materials listed in Section 1.3 are suitable for operation in the temperature range stated above, including the buna-N elastomer which has an*

*operating range of -40° C to +100° C. Also, the Lexan<sup>®</sup> cover has an operating temperature range of -135° C to +115° C.*

**External Pressure** 25 kPa absolute (60 psi) to atmospheric

*This is not applicable to the secondary enclosure because it does not appear possible for the pressure in the tunnel to exceed one atmosphere.*

**Impact** 50 grams (1-3/4 oz.) from 1 meter, or equivalent imparted energy

*The most vulnerable components in the target system are the sapphire windows. A successful impact test on a 6-mm thick sapphire window was done using a 1.75-cm diameter "paintball," with a speed of 95 m/s. Its momentum was the same as that of a 7-mm diameter mercury droplet with a velocity of 95 m/s. [4]*

**Vibration** 3 times 10 minutes, 25-500 Hz at 49 m/s<sup>2</sup> (5 g<sub>n</sub>, acceleration maximum amplitude)

*Presumably, this could apply to the target equipment located in the TT2A tunnel to prevent the equipment from moving during a seismic event. If this is deemed to be a requirement, the base support structure can be anchored to the tunnel floor.*

**Puncture** 1 gram (0.03 oz.) from 1 meter, or equivalent imparted energy

*By inference, a sharp object with such little momentum will not penetrate any portion of the 12.7-mm thick Lexan<sup>®</sup> cover or the 6-mm thick stainless steel sides of the secondary enclosure.*

## 2.2 Geometry

The geometric configuration of the target system is based on the following criteria that optimizes muon production and results in a full-beam interaction length of 30-cm:

- Proton beam, solenoid axis, and Hg jet all reside in a common vertical plane,
- Solenoid axis tilted 67 milliradians (3.84°) with respect to proton beam,
- Hg jet flows from the "up-beam" to the "down-beam" direction, the same direction as the proton beam,
- Hg jet begins above the proton beam and crosses the beam at an angle of 33 milliradians (1.89°),
- The jet crosses the beam at  $Z = 0$ , the center of the solenoid and location of the highest intensity magnetic field,
- Nominal height of the proton beam is 120-cm (47.64-in.) above the tunnel floor,
- Service end of the solenoid is positioned in the "up-beam" direction, and
- The mercury pumping loop is located "down-beam" of the solenoid.

Relative to the magnetic axis,  $Z = 0$  at the center of the solenoid bore,  $-Z$  refers to the "up-beam" end of the solenoid, and  $+Z$  refers to the "down-beam" end.

The technical limitations of the PS accelerator machine allow the extraction of beam pulses at 24 GeV/c with a length of up to two micro-seconds, which corresponds to a single turn

extraction. Beyond this time limit (multi-turn fast extraction), the kicker has to be fired at least twice to achieve pulse lengths longer than two micro-seconds. The capacity of the power supply for the kicker is limited such that for multiple kicks, the momentum of the beam has to be reduced to 14 GeV/c. The aim of the experiment is to study pulse lengths up to 100 micro-seconds.

Figure 2 shows the overall geometry of the target system. Note the horizontal “kick” of 7 milliradians ( $0.4^\circ$ ) in the proton beam starting at  $Z = 0$ , for a 24 GeV beam energy. This kick increases to 12 milliradians ( $0.7^\circ$ ) for a 14 GeV beam.

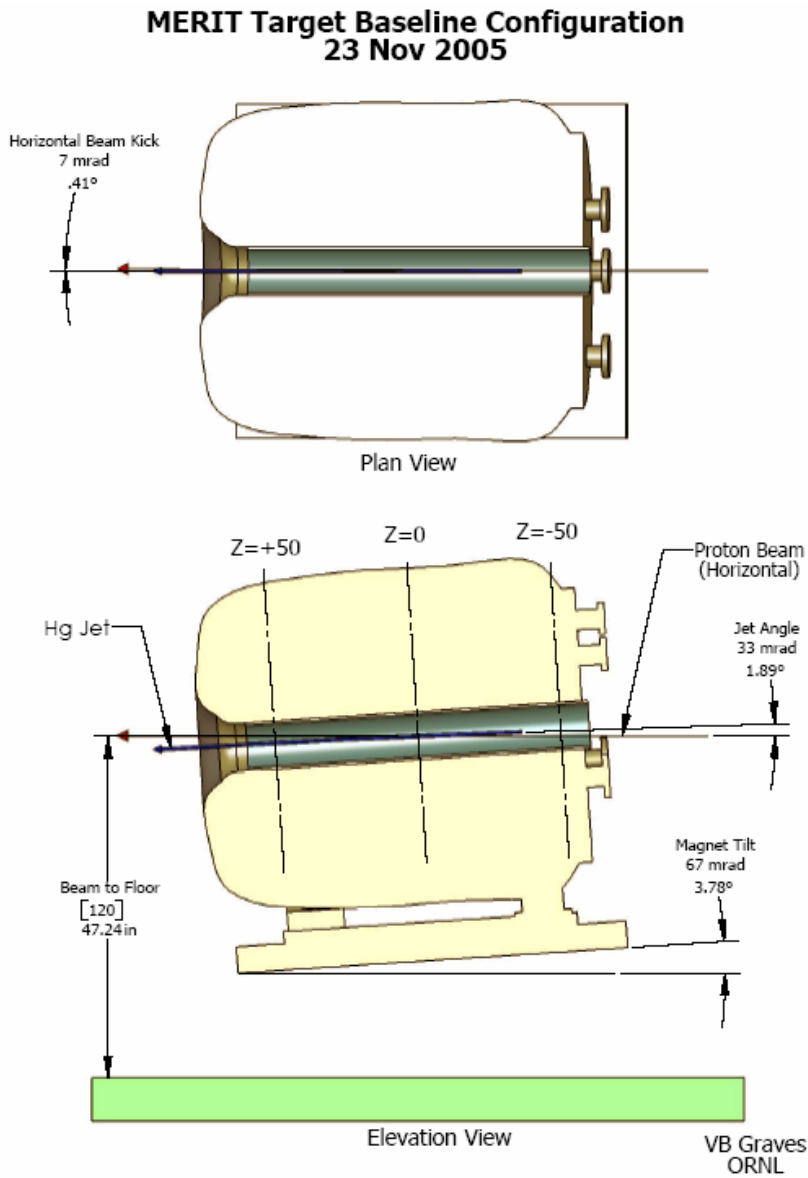


Figure 2. MERIT baseline geometry configuration.

Figure 3 shows a detailed view of the geometric relationships between the magnetic axis, the beam axis, and the Hg jet.

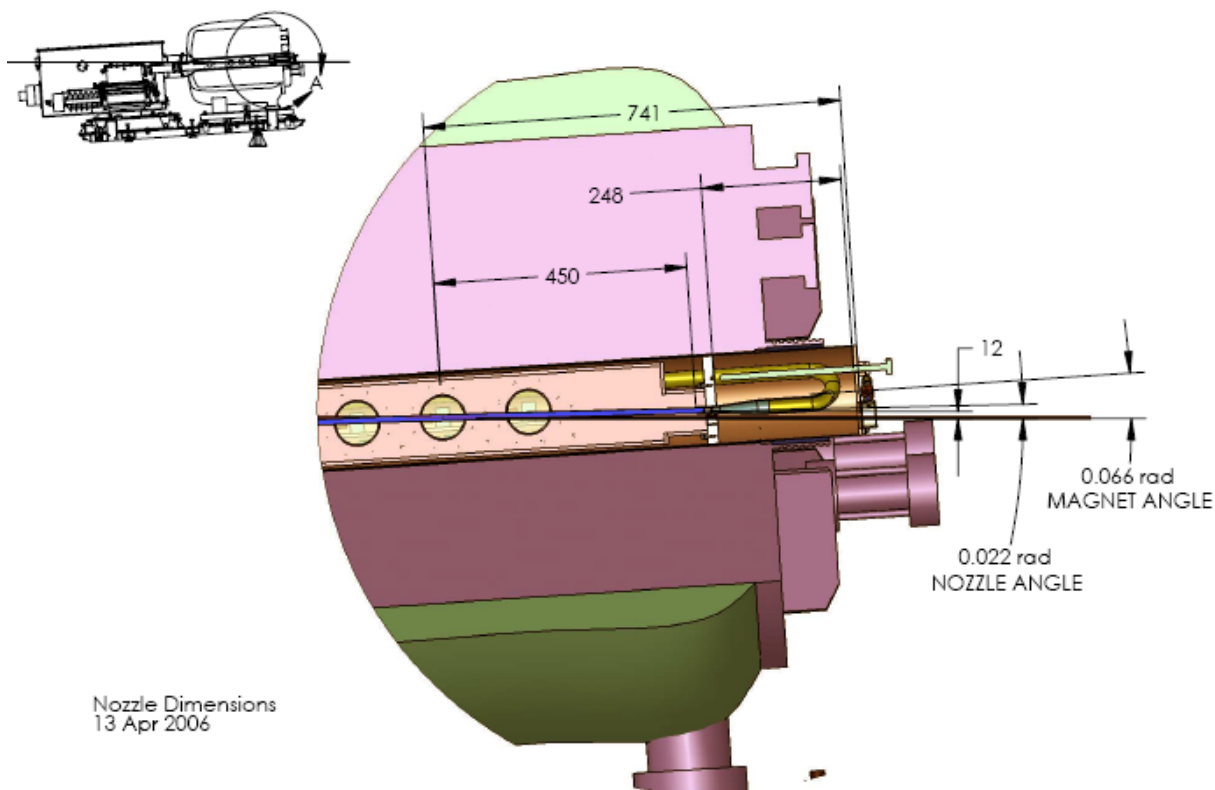


Figure 3. Nozzle and solenoid relative to beam.

### 2.3 Operating Temperature

The operating temperature of the mercury is estimated to be between 15 C° and 35 C°. Testing at ORNL will determine the actual temperature rise after each pulse of the jet, by monitoring the temperature sensor located in the sump tank. The goal is to ensure that the temperature rise in the mercury inventory remains well below the boiling point of Hg. This should be easily demonstrated because the dwell time between pulses is nominally 30 minutes.

### 2.4 Mercury Containment Boundaries

#### Primary Containment

The primary containment boundary is defined as that which is mercury-wetted hardware. The primary containment includes the Hg cylinder, the nozzle and supply piping, the jet chamber with attached proton beam windows and optical diagnostic viewports, and the sump tank with its associated piping. The primary containment incorporates a minimal number of valves and fittings to reduce the possibility of leakage and to minimize flow losses in the Hg. Figure 4 shows the primary containment equipment.

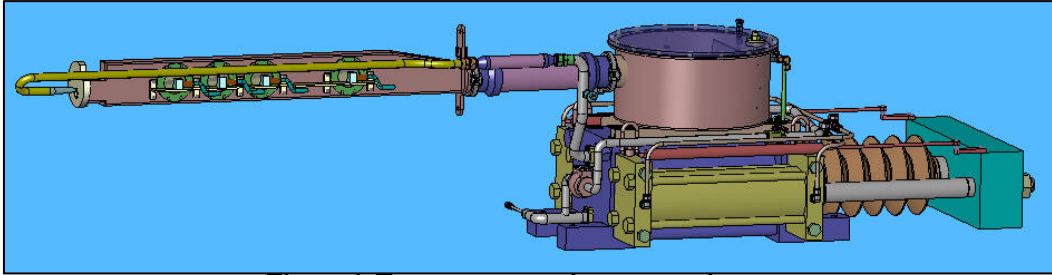


Figure 4. Target system primary containment.

Secondary Containment

The secondary containment provides the means to monitor for the presence of Hg vapor in the event of a leak in the primary containment boundary. Figure 5 is a schematic of the primary and secondary containment boundaries.

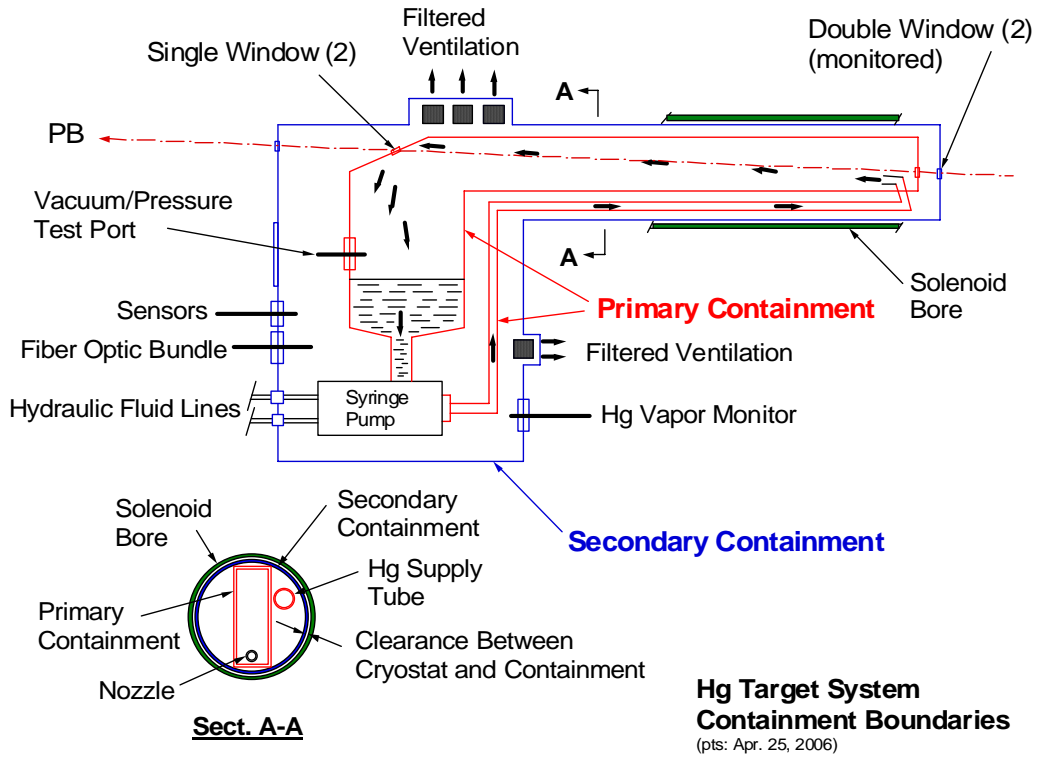


Figure 5. Target system containment boundary schematic.

## 2.5 Windows

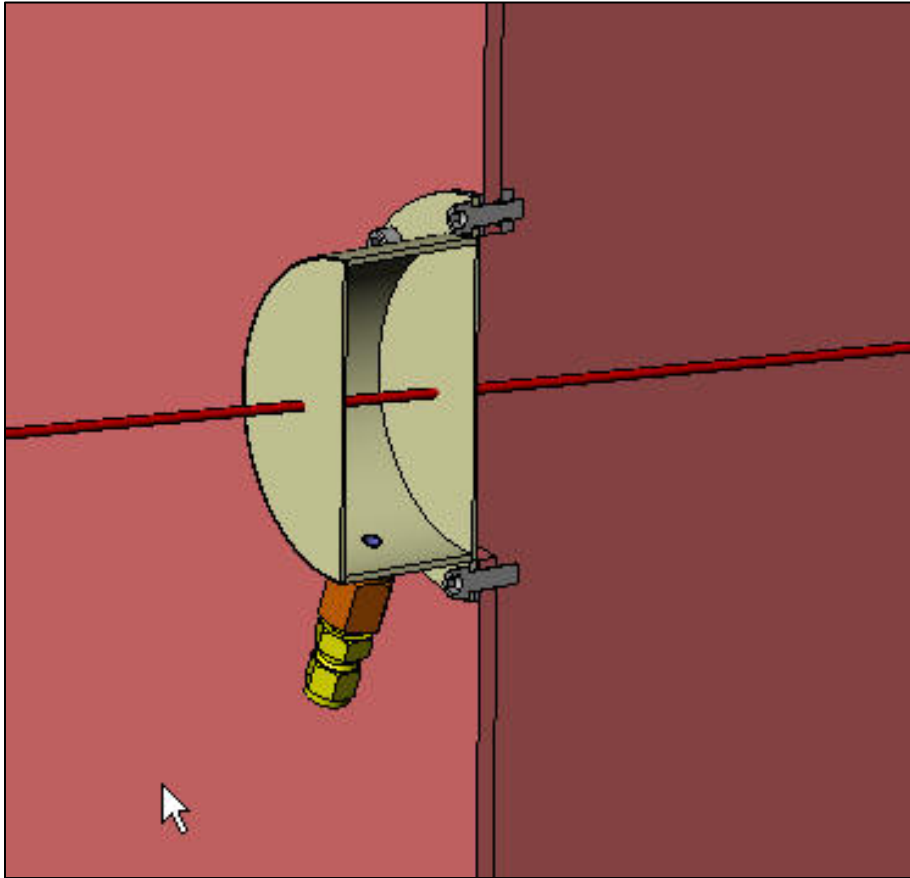
### Primary Containment Windows

Two types of windows are mounted to the primary containment boundary, the proton beam windows and the diagnostic optical windows [1]. The proton beam windows are single-layer, 1-mm thick, made from Ti6Al4V material. The deflector window, also made from Ti6Al4V, is 2-mm thick because it is possible for the downstream jet to impinge on this window. The diagnostic windows are optically transparent, single layer, 6-mm thick, made from sapphire material. The diagnostic windows provide the ability to optically view the interaction region at four locations along the axis of the proton beam line. The diagnostic windows and the laser components will be provided by BNL. They were designed to meet the interface requirements of the primary containment; therefore the diagnostic equipment will be installed as a module.

### Secondary Containment Windows

The proton beam windows that are mounted to the secondary containment are double windows with interstitial monitoring for failure due to beam interaction. The windows are 1-mm thick, made from Ti6Al4V. Figure 6 shows a double window mounted to the secondary containment; the proton beam is shown in red.

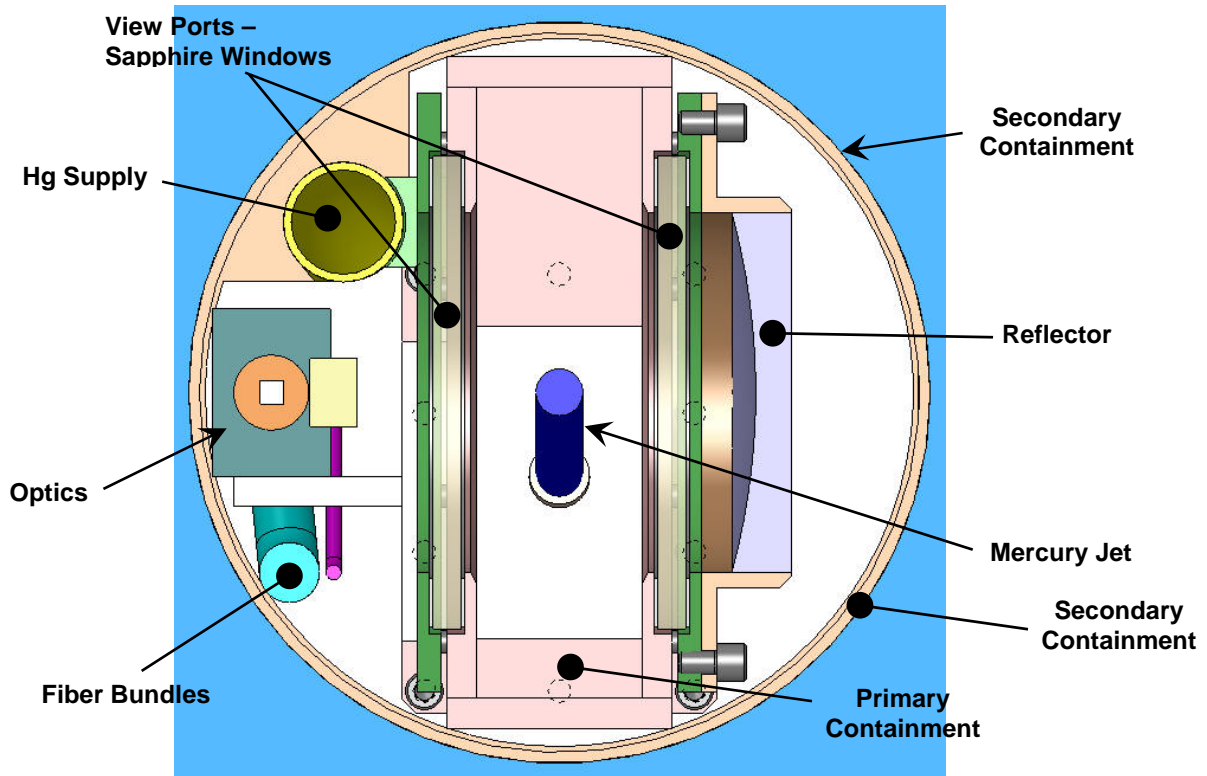
In the MERIT Hg system, the beam passes through three windows prior to interaction with the Hg jet and three windows after jet interaction.



**Figure 6. Downstream beam window mounted to the secondary containment enclosure.**

Diagnostic Windows

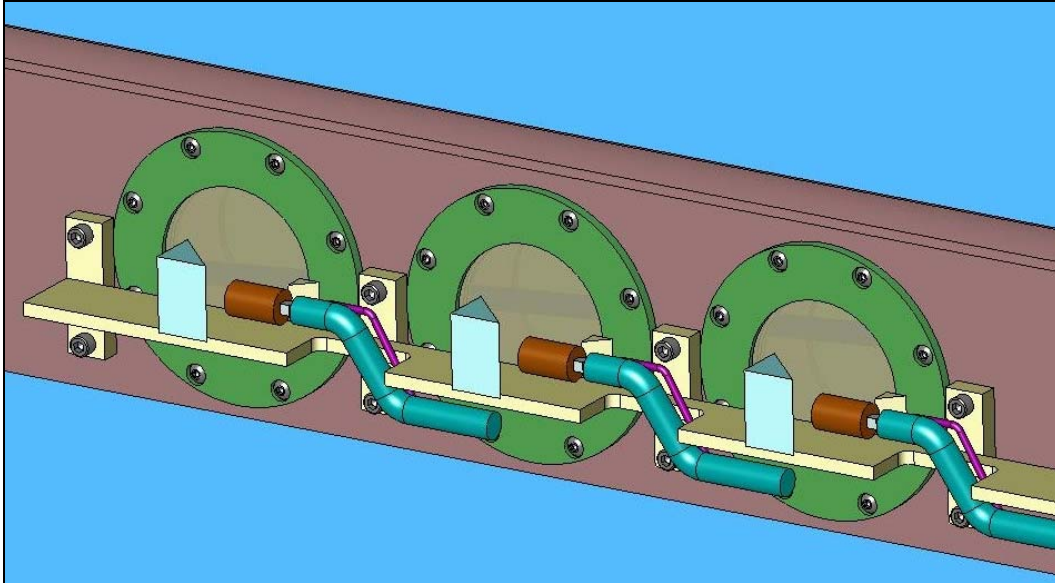
The diagnostic windows are mounted on the primary containment at four viewing locations. Each window is made from 6-mm thick sapphire and is mounted in a retaining ring. The backside viewports also contain a reflector assembly. Figure 7 is a section cut taken at  $Z = 0$  and shows the various components that make up the laser diagnostic as well as the containment boundaries, the mercury supply line, and the jet.



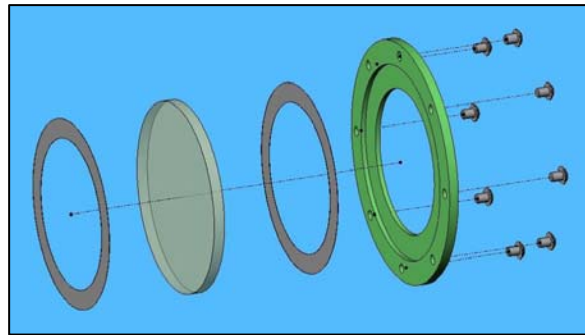
**Figure 7. Laser diagnostic components, windows, and reflector; section cut taken at  $Z = 0$ .**

Figure 8 shows a representative diagnostic support bracket and three of the four fiber bundles, prisms, and retaining rings and windows. Brookhaven National Laboratory (BNL) is responsible for the design and fabrication of the optical diagnostic components. Figure 9 is a window assembly that includes elastomer gaskets on both sides of each window, and Figure 10 shows the reflector assemblies mounted opposite to each of the windows for the incoming laser light. The viewports are located at  $Z = -15, 0, +15,$  and  $+30\text{cm}$ .

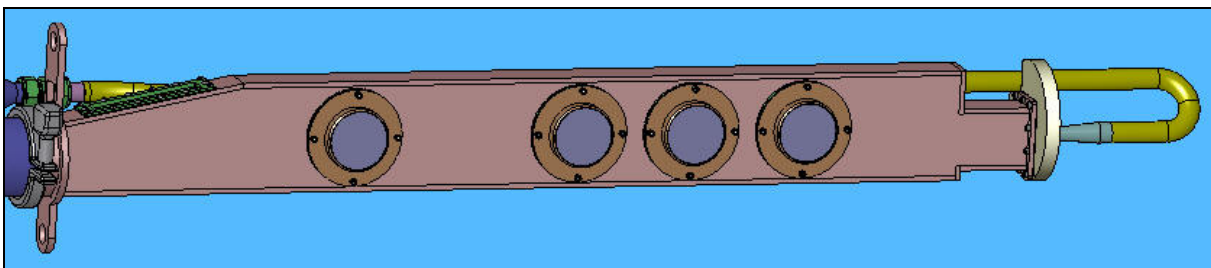




**Figure 8. Passive optical diagnostic components and support bracket.**



**Figure 9. Sapphire window mounted between elastomer gaskets.**



**Figure 10. Diagnostic reflector assemblies.**

Since these diagnostic assemblies have many potential leak paths, each gasketed joint will be leak-checked using the soap bubble technique prior to the start of water test operations, and again prior to starting tests with mercury.

## 2.6 Alignment

The target system base support structure has provisions to align the assembled target for insertion into the solenoid bore, and provisions to position the assembled solenoid/target system to the proton beam line within 1-mm. The position of the solenoid/target will be determined by taking measurements from fiducials mounted to the solenoid and target module along with beam diagnostic measurements made by the CERN PS group. Movement of the target module within the magnet bore is a concern, and a wedge system may be incorporated to hold the module rigidly within the bore. This issue will be resolved during ORNL/MIT testing.

## 2.7 Assembly and Shipping

The design and fabrication of the target system and the base support structure carefully considered the ease of assembly and disassembly, handling for transport, and handling for installation. Initially, the equipment will be shipped to MIT and back to ORNL by truck, and then to CERN in a sealand container. The target system was designed to meet the space requirements for moving components from above ground at CERN into the tunnel areas leading to tunnel TT2A, and for the handling requirements needed by the CERN Rigging Group. Each major component has provisions for overhead lifting and pallet-like handling, and the base support structure has rotatable casters for moving the assembled target system into (and out of) the beam line. Section 6.0 discusses details about the packing and transportation of the target equipment (and the solenoid).

## 2.8 Component Size and Weight

Table 1 is a listing of the weight of each component that may be separately handled during installation at MIT or CERN.

**Table 1. Estimated Component Sizes and Weights.**

	<b>Approximate Dimensions</b> Centimeters (inches)	<b>Est. Weight</b> Kilograms (pounds)
<b>MERIT (fully assembled)</b>	406x119x165 (160x47x65)	7250 (16000)
<b>Primary Containment</b>	356x81x74 (140x32x29)	860 (1900)
<b>Secondary Containment</b>	396x107x135 (155x42x53)	680 (1500)
<b>Base Support Structure</b>	320x127x30 (126x50x12)	360 (800)
<b>Target Cart</b>	117x84x20 (46x33x8)	80 (175)
<b>Target Transporter</b>	157x119x30 (62x47x12)	160 (350)
<b>Magnet Beam Support</b>	127x25x18 (50x10x7)	14 (30)
<b>Hydraulic Cart (w/o oil)</b>	172x102x152 (68x40x60)	1000 (2200)
<b>Hydraulic Fluid Drum</b>	61dia x 97tall (24dia x 38tall)	230 (500)
<b>Mercury Flask</b>	15dia x 30 tall(6dia x 12tall)	34 (76)
<b>Solenoid</b>	1800x940x1250 (708x370x490)	5440 (12000)

## 2.9 Instrumentation

Various instruments connected to the MERIT remote control station have been incorporated into the target system design to monitor the following parameters:

- Mercury vapor sensor to monitor the secondary containment atmosphere.
  - The present plan is to place the sensor in the TT2 tunnel out of the radiation environment, with a long sampling tube connected directly to the secondary containment, as shown in Figure 5. Testing at ORNL will determine if locating the vapor sensor up to 10 meters away will provide reliable monitoring information, as well as the time delay for the measurement. If not, then the vapor sensor will be mounted on top of the secondary enclosure, where it receives minimal radiation exposure.
- Temperature sensor to monitor the mercury in the sump tank.
  - This sensor will be used to monitor the Hg temperature rise after each pulse.
- Position sensor mounted to each drive cylinder to monitor flow in the supply line.
  - Two position sensors (for redundancy), one mounted to each drive cylinder, will be used to calculate the flow rate of the mercury. The Labview controller will convert the linear displacement information into nozzle velocity.
- Pressure sensors in the hydraulic system, located at the hydraulic pump discharge (supply line) and the return line.
  - The arithmetic difference between these two sensors will indicate the pressure drop in the hydraulic loop, and will be used monitor performance of the drive cylinders.
- Pressure sensor at the discharge end of the pump cylinder.
  - This sensor will monitor the Hg pressure near the Hg cylinder discharge, which will provide a means of determining total pressure drop in the Hg supply line. This information will be used to corroborate the results of the pipe flow analysis and will also quantify the additional pressure drop caused by the magnetic field.
- Hydraulic reservoir low-level sensor with cutoff switch.
  - This sensor will monitor the hydraulic fluid level in the 150 liter (40-gal.) reservoir tank and will automatically shut down the syringe pump system if there is a loss of fluid.
- Conductivity probe located at the low end of the secondary enclosure to monitor for a major leak.
  - In the event of a major leak from the primary containment, the conductivity probe will send a signal to the Hg system controller.

Table 2 is a listing of the various Hg system instruments arranged by type of sensor signal.

**Table 2. List of sensors for the target system.**

<b>Controlled Components</b>			
<b>Hydraulic pump</b>	<b>Proportional control valve*</b>	<b>Heater foil</b>	
<b>Analog Sensor Inputs</b>			
<b>Hg discharge pressure</b>	<b>Hg level</b>	<b>Hg sump thermocouple</b>	<b>Secondary containment thermocouple</b>
<b>Cylinder 1 position*</b>	<b>Cylinder 2 position</b>	<b>Hg vapor 1*</b>	<b>Hg vapor 2*</b>
<b>Hydraulic fluid high pressure</b>	<b>Hydraulic fluid low pressure</b>	<b>Beam window 1 pressure*</b>	<b>Beam window 2 pressure*</b>
<b>Digital Sensor Inputs</b>			
<b>Hydraulic filter dirty switch</b>	<b>Hydraulic low level switch</b>	<b>Conductivity probe</b>	

\* Denotes a critical sensor for system operation or safety.

It is important to keep in mind that the main purpose of the sensors is to provide the operator with information that cannot be viewed directly because of the hazardous environment during testing, and the fact that the operator will be located in a separate building.

Finally, although these are not instruments, it is worth mentioning that the top covers of the secondary enclosure and sump tank are clear Lexan<sup>®</sup>. This permits visual inspection of the syringe pump equipment and also allows viewing the return flow of water or mercury into the sump tank during system testing.

## 2.10 Stray Magnetic Fields

The target system will operate in magnetic fields [2] as high as 15 Tesla at the center of the solenoid (at  $Z = 0$ ,  $R = 0$ ), decreasing to hundredths of a Tesla for equipment located away from the beam interaction point at  $Z = 0$ . Figure 11 is a plot of the stray magnetic fields as a function of  $R_{xyz}$  relative to the position of the pump system; the 15 Tesla location is at the center of the solenoid.

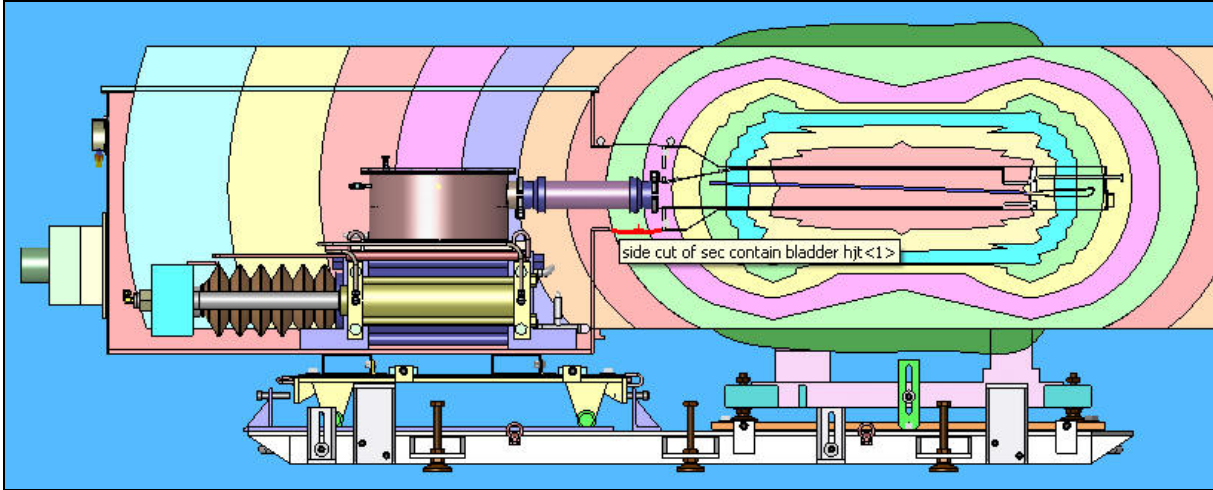


Figure 11. Stray magnetic field plot around the solenoid and the target equipment.

Figure 12 shows the magnitude of the field contours. The nozzle is located in a field that is  $>9.7$  T, and the syringe pump cylinders are located in a field that ranges from  $0.26 - 0.1$  T. The structural beam that connects the two drive cylinders to the pump cylinder will translate in a field that is  $>0.03$  T. By using non-magnetic materials for the target system, the need to calculate and design for Lorentz forces was unnecessary.

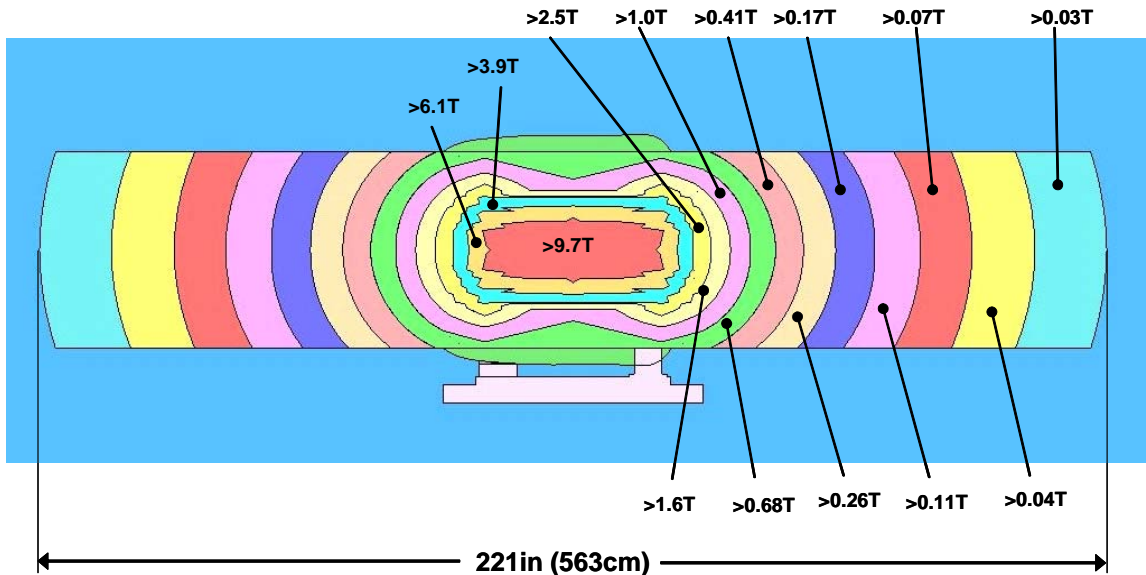


Figure 12. Magnitude of the field contours.

### 2.11 Radioactivation of Components

Simulation analysis using the MARS 15 Code [3] indicated that the levels of radioactivity for the target system are low enough to permit hands on access to most of the target equipment and the mercury inventory, after relatively short cool down periods. Table 3 is a listing of representative components for the target equipment that shows absorbed dose, dose rates at shutdown, and dose rates after extended cool down periods. The information was taken primarily from Reference 3.

**Table 3. Radioactivity of Target System Components.**

<b>Component</b>	<b>Absorbed Dose</b> (Gray/ $3 \times 10^{15}$ protons)	<b>Residual Dose Rate – at Shut Down</b> (mSv/h $3 \times 10^{15}$ protons/30day)	<b>Residual Dose Rate – at Shut Down</b> (mrem/h)	<b>Residual Dose Rate – 100 Hrs Cool Down</b> (mSv/h $3 \times 10^{15}$ protons/30day)	<b>Residual Dose Rate – 100 Hrs Cool Down</b> (mrem/h)
Equipment in solenoid bore	$10^4 - 10^6$	1	100	-	-
Equipment in secondary enclosure	$10^2 - 10^4$	-	-	-	-
Syringe Pump	-	$10^{-2} - 10^{-3}$	1.0 – 0.1	-	-
Top of secondary enclosure	-	$10^{-2} - 10^{-4}$	1.0 – 0.01	-	-
Hg vapor monitor (top of enclosure)	14.0 (<5-10 krad for electronics)	0.95	95.0	$<2.70 \times 10^{-3}$	<0.27
Hydraulic fluid	125	0.023	2.30	$<1.13 \times 10^{-4}$	<0.01
Ventilation filter in secondary encl. (1)	505	1.55	155.0	$<9.70 \times 10^{-4}$	<0.09
Mercury	$10^1 - 10^2$	$10^{-1} - 10^{-2}$	10.0	$30 \times 10^{-3}$ (2)	3.0 (2) (3)

(1) Pure carbon material used for calculation; impregnated sulfur not included.

(2) 1 day of decay at 1 meter distance; M. Magistris and M. Silari, EDMS No. 601754, CERN Technical Note CERN-SC-2005-049-RP-TN, June 16, 2005.

(3) After 1 month, dose rate at 1 meter distance is 0.1 mrem/h.

### 3.0 Component Design and Analysis

#### 3.1 Flow Analysis

An analysis of the Hg flow was performed using Applied Flow Technologies (AFT) Fathom software. Fathom is not a computational flow dynamics (CFD) program; rather it is a tool used to model incompressible flow systems and includes provisions for modeling networked piping systems, pumps, valves, etc. It provides flow characteristics such as pressure & velocity as well as frictional losses throughout the entire piping system. It does not include any magnetohydrodynamic effects, so only the no-magnetic field condition is simulated.

The Hg flow from the cylinder to the nozzle was modeled in Fathom, with geometry sizes, lengths, and elevation information obtained from the CAD model of the piping system. Fathom uses a junction – pipe terminology to describe a system: junctions are "nodes" such as tees & elbows, and pipes connect the junctions. A schematic of the model is shown in Figure 13. The Hg cylinder was modeled as a constant flow source, and the nozzle exit was modeled as a specified pressure of 1-atmosphere. The analyses referenced in this section are included in Appendix A.

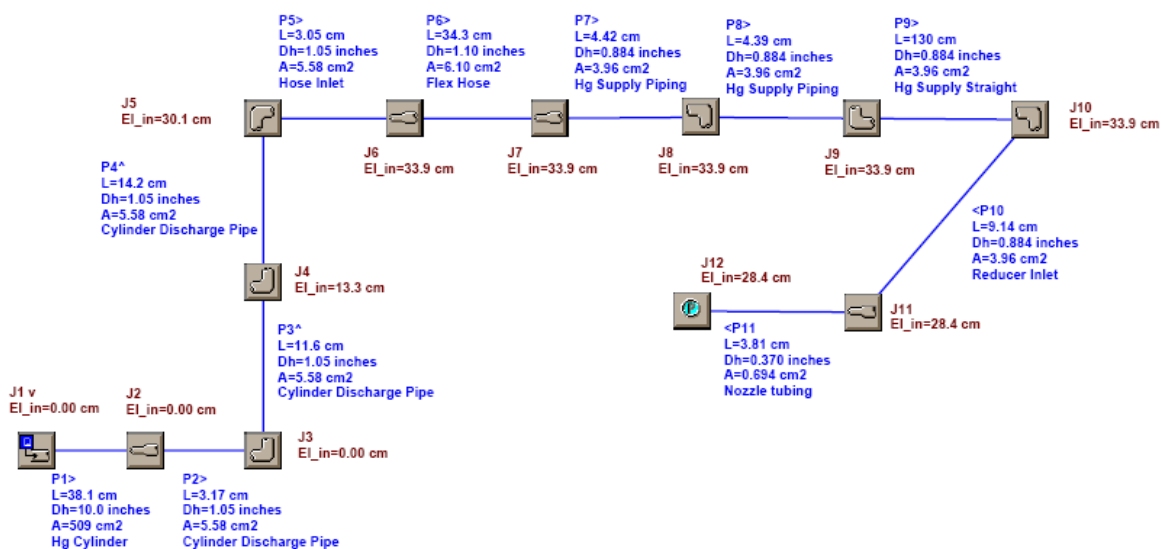


Figure 13. Fathom input model.

By calculating the flow-induced pressure drops throughout the nozzle supply piping, an estimate of the maximum Hg cylinder pressure can be obtained. Results of this analysis (shown in Figure 14) showed a cylinder pressure of approximately 45 bar (650 psi) for nominal flow conditions of 1-cm-dia, 20-m/s Hg jet, which requires 1.6 liter/s (25 gpm). As described in Sections 3.2 and 3.3, the cylinder and primary containment have a design pressure of 100 bar (1500 psi) to accommodate any under-estimation of the system pressure drop as well as MHD-induced pressure losses.

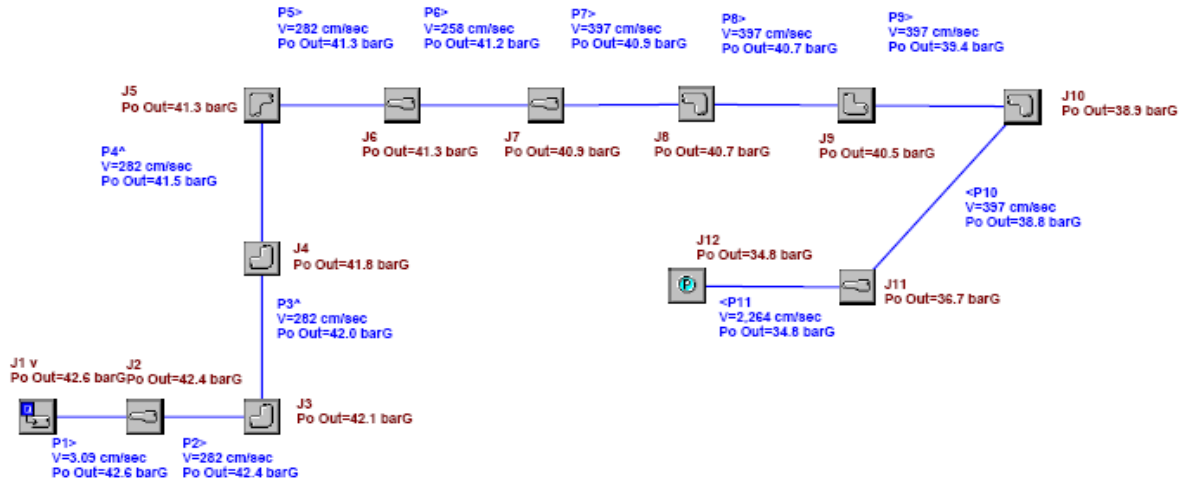
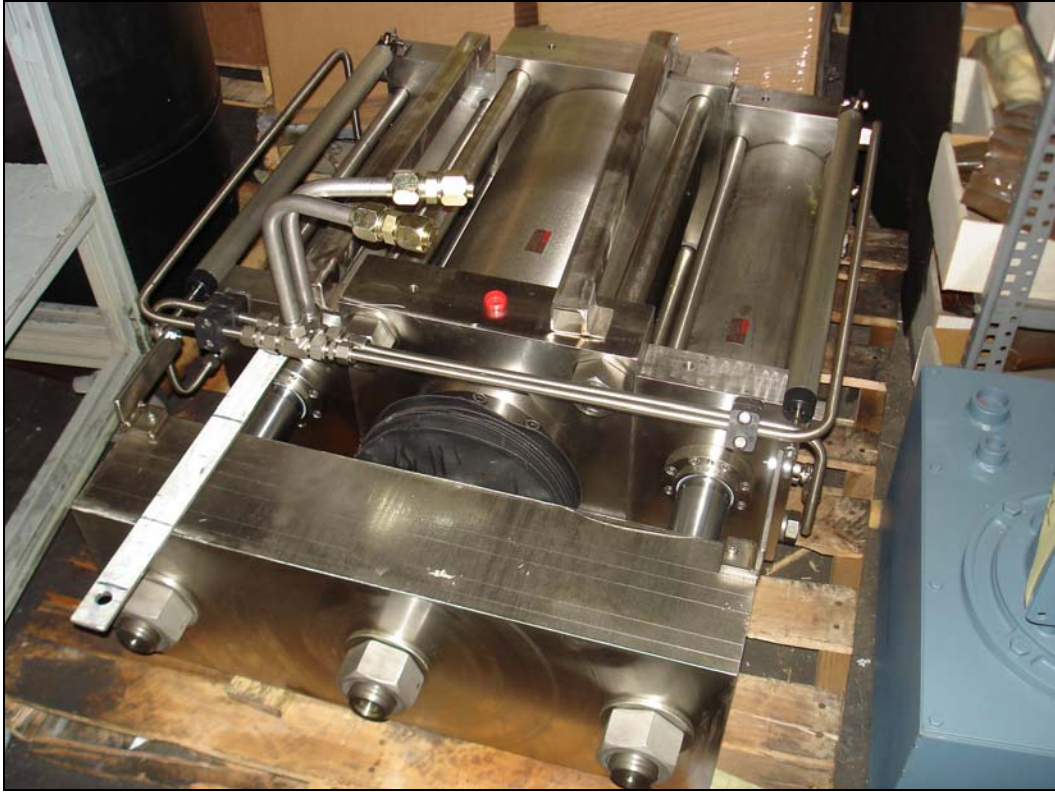


Figure 14. Fathom stagnation pressure output.

### 3.2 Syringe Pump System

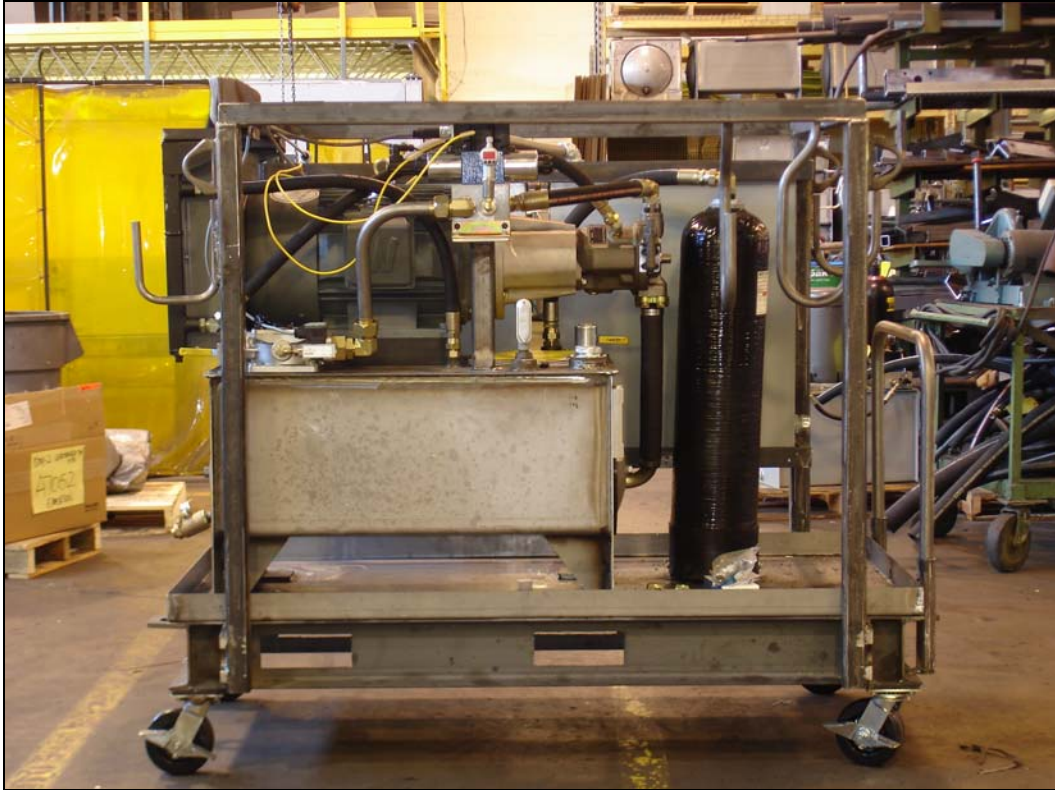
Due to the intermittent nature of the MERIT experiment and also due to pressure and temperature issues in using a centrifugal pump, a syringe pump was chosen as the Hg fluid mover. The Hg cylinder was sized to provide up to 12 sec of jet at nominal flow conditions. Due to the geometric restrictions of the experiment equipment layout and installation of the system into the TT2A tunnel, the Hg cylinder size was chosen as 25.4-cm (10-inch) diameter and 38.1-cm (15-inch) stroke, with two side-mounted hydraulic cylinders that will provide motion to the syringe. The fully assembled pump system is shown in Figure 15. A large tie-beam is used to connect the drive cylinder rods to the Hg cylinder rod; the two drive cylinders are actuated in unison through the hydraulic system piping. Since the three cylinders are only connected through the tie-beam, the cylinder volumes are completely separated, so no interaction between the Hg and the hydraulic fluid is possible. All cylinder and tie-beam materials are non-magnetic due to the relative proximity to the high field of the solenoid.





**Figure 15. Syringe pump cylinders.**

The hydraulic power unit (HPU) which actuates the drive cylinders is shown in Figure 16. The pump system will be located in the TT2 tunnel; hoses connecting the drive cylinders with the pump will traverse through the wall separating the TT2 and TT2A tunnels. Low-flammability, vegetable-oil-based hydraulic fluid is used.



**Figure 16. Hydraulic pump system.**

The HPU has on-board manual controls (shown in Figure 17) for basic syringe pump operation, but they are not designed for the precise velocity control needed in the MERIT experiment. Power On/Off, system enable, local emergency stop, and HPU diagnostic indicators are the only local controls provided. A separate pendant-controlled emergency stop is also part of the HPU system. A laptop computer running Labview software will be used as the remote control system. More details of this control scheme are provided in Section 3.6.



Figure 17. Syringe HPU on-board controls.

Design and fabrication of the syringe pump system was performed by Airline Hydraulics Corporation (Bensalem, PA, USA). Design calculations and other documentation for the syringe pump system are included in Appendix B. A summary of the syringe system design and performance characteristics is shown in Table 4.

Table 4. Syringe Pump Performance Parameters.

Parameter	Value/Description
Design Standard	ANSI/B93.10-1996, <i>Static Pressure Rating Methods of Square Head Fluid Power Cylinders</i>
Dimensions	Hg cylinder: 25.4cm (10in) dia, 38.1cm (15in) stroke, Drive cylinders: 15.2cm (6in) dia, 38.1cm (15in) stroke
Piston Velocity	3cm/sec (1.2in/sec) at nominal condition
Design Pressure	Hg cylinder: 103 bar (1500psi) Drive cylinders: 206 bar (3000psi)
Pump Pressure	206 bar (3000psi)

Parameter	Value/Description
Operational Safety Features	Hydraulic fluid high temperature switch High pressure relief valve
Hoses	3/8-inch, stainless steel
Hydraulic Pump Reservoir	40 gal
Hydraulic Fluid	Quintalubric-888

### 3.3 Primary Containment

By definition, the primary containment system consists of all the Hg-wetted components and includes the Hg cylinder, nozzle and associated supply piping, jet chamber and optical view ports, primary beam windows, and the sump tank with its associated piping. Figure 18 shows a model of the entire primary containment system. With the exception of seals, all primary containment components are stainless steel, titanium, Teflon, or sapphire.

The target module of the primary and secondary containments is that portion of the target designed to fit within the bore of the solenoid. During the thermal cycle of the solenoid, its bore will shift vertically and axially on the order of a few millimeters. Because the target module sits in the solenoid bore, it must also be able to accommodate these positional shifts and therefore, incorporates flexibility in the supply and return Hg flow paths through the use of short sections of hose; all other Hg flow path components are rigid.

#### Description & Pressures

Primary containment is designed as a closed-volume with a 1-atm air environment. The volume consists of the sump tank, both sides of the Hg cylinder, and all Hg piping. As the Hg cylinder is extended and retracted, the air volume on the rod-end of the cylinder is connected to the sump tank through tubing, so if a significant quantity of Hg leaks past the piston seals, it would be directed back into the sump tank as the cylinder extended. In addition, the Hg cylinder rod may be exposed to Hg vapor inside the cylinder; the rod is covered with a bellows to prevent any vapors from entering the secondary containment, and the bellows is vented directly to the secondary containment (primary) charcoal filter.

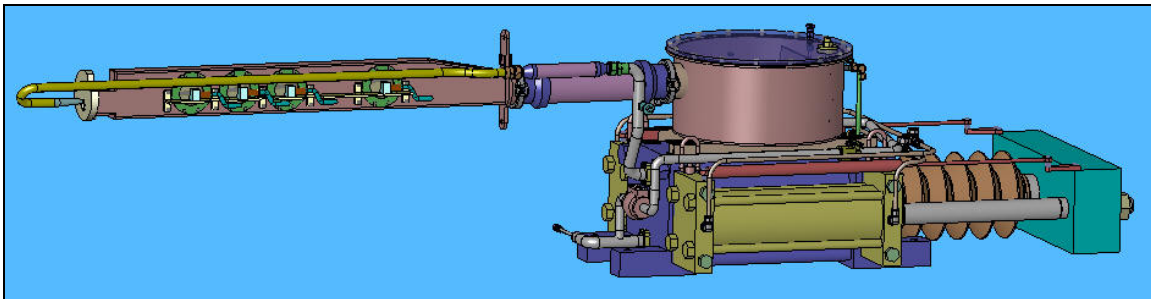
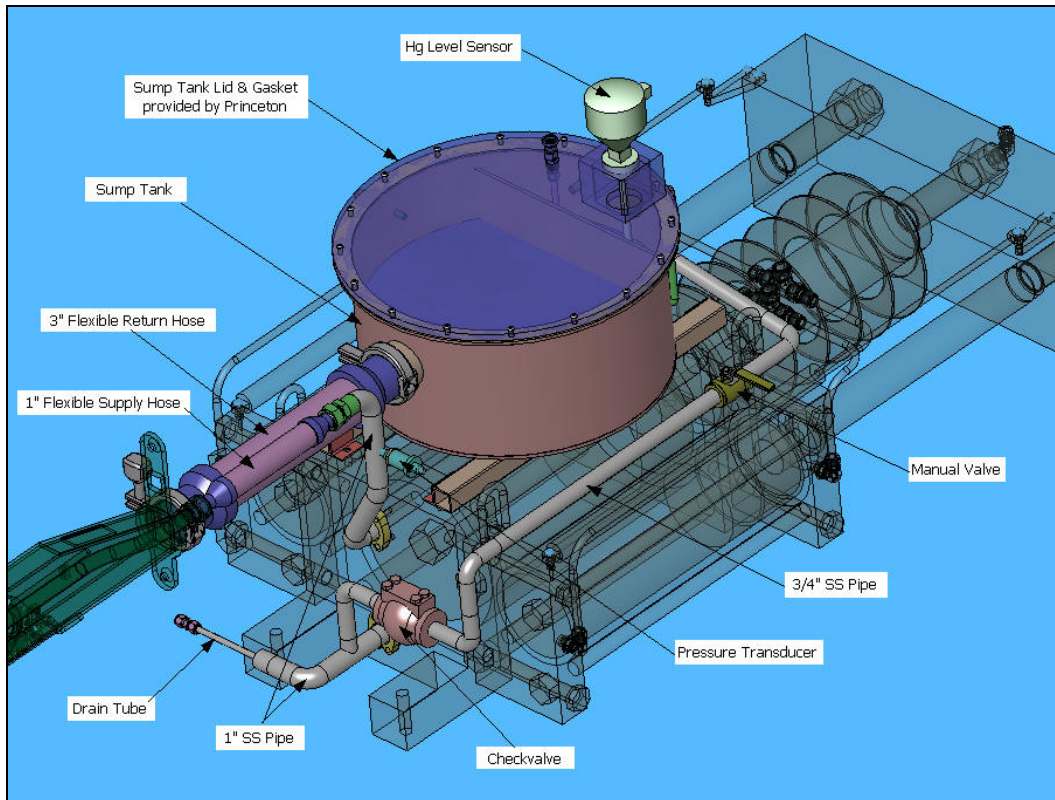


Figure 18. Primary containment.

While the entire primary containment is exposed to contact with Hg liquid or vapors, not all of it is exposed to high pressure. The Hg jet chamber, the return hose, the sump tank, and the sump tank drain line to the check valve should never experience pressures over atmospheric during normal operations. Leak checking operations may require that these components be pressurized to 1atm gauge or possibly vacuum conditions.

No operating scenario is expected in which the sump tank will experience an over-pressure condition. However, should one occur, the sump tank incorporates a check-valve to protect the system, and the check-valve exhaust is vented to the charcoal filter. This protection system may actuate during the Hg fill operation since Hg will displace air inside the sump tank.

Flow through the system is as follows and is partially shown in Figure 19. The Hg cylinder is fitted with two flanged ports on the piston end; the lower one is the inlet, and the upper one is the discharge. Hg is gravity-fed from the sump tank to the cylinder inlet as the cylinder is slowly extended and flows through a manual shut-off valve and a check-valve. Since the manual valve is not accessible through the secondary containment, its primary use will be during ORNL testing, and it will remain open during shipment and installation at MIT and CERN. The Hg cylinder inlet also serves as the system drain and is plumbed through a manual valve and quick-disconnect to the secondary containment wall; the valve protects the quick-disconnect and will be exposed to cylinder pressure during each stroke of the cylinder. The check-valve prevents Hg from returning to the sump tank during a stroke.



**Figure 19. Sump tank and piping.**

During a pressure stroke, Hg is expelled from the cylinder through the discharge port and travels through the nozzle supply piping, performs a 180° change of direction and a reduction in flow area, and is finally ejected into the jet chamber as a 1-cm diameter jet. The majority of the Hg supply piping is 1-inch Schedule 40 and 3/4-inch Schedule 10 welded piping and is fabricated to ASME IX standards. Commercially available components were used wherever possible. Table 5 lists all the components that will be pressurized during a stroke. It is noted that the Hg supply components were designed to match the pressure rating of the Hg cylinder, but since the Hg pressure increases from the nozzle to the cylinder, as long as the cylinder pressure does not exceed its rating, the pressure in the downstream components cannot exceed the cylinder pressure. The Hg pressure will be monitored close to the cylinder discharge, and the system pressures will be fully characterized through testing at ORNL and MIT prior to equipment installation at CERN.

**Table 5. Hg Supply Component Pressure Ratings.**

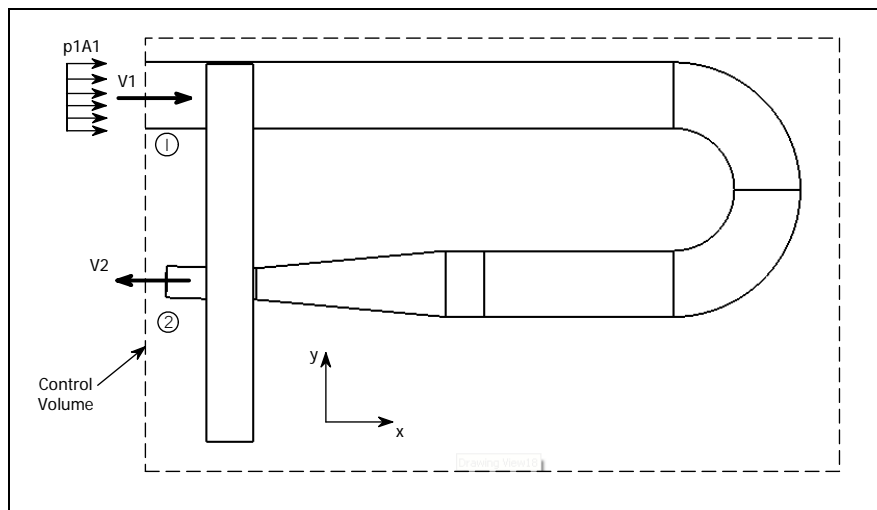
<b>Component</b>	<b>Dwg Ref</b>	<b>Material</b>	<b>Description</b>	<b>Pressure Rating, bar (psi)</b>
Hg cylinder	203-HJT-0600 Item 1	SS	10-inch bore, 15-inch stroke NFPA cylinder	103 (1500)
Cylinder drain tubing	203-HJT-0680	SS	3/8-inch, 0.065" wall rigid tubing	350 (6500)
Cylinder drain valve	203-HJT-0760	SS	Swagelok SS-8UW-TP3	170 (2500)
Cylinder drain quick-disconnect	203-HJT-0760	SS	Swagelok SS-QC6-S1-600	103 (1500) coupled, 17 (250) uncoupled
Cylinder discharge	203-HJT-0670	SS	1-inch, SCH40 piping	130 (1900)
Hg cylinder inlet piping	203-HJT-0680	SS304L	3/4" SCH40 piping	225 (3300) per ASME IX
Hg cylinder inlet piping	203-HJT-0680	SS304L	1" SCH40 piping	210 (3100) per ASME IX
Hg cylinder inlet checkvalve	203-HJT-0680	SS	Warren 1503HF	103 (1500)

Component	Dwg Ref	Material	Description	Pressure Rating, bar (psi)
Pipe weld connector	203-HJT-0670	SS	Swagelok 1" SS-1610-1-16W	165 (2400)
Flexible hose	203-HJT-0670	SS/Teflon	Swagelok 8R series	137 (2000)
Hg supply line	203-HJT-0620	Ti	3/4-inch SCH10 piping	165 (2400)
Hg supply reducer	203-HJT-0624	Ti6Al4V	Custom design	180 (2600)
Nozzle	203-HJT-0620	Ti	12-mm, 1-mm wall rigid tubing	200 (2900)

As the jet leaves the nozzle, it will be contained within the jet chamber and may strike the titanium deflector plate that also serves as the primary exit beam window. To make the window design more conservative, the window thickness was increased from 1mm to 2mm to accommodate the impact loading of the Hg jet. The Hg exits the rectangular chamber and returns to the sump tank through a 4-inch flexible stainless steel hose.

Flow Forces

An analysis of the flow forces in the Hg supply line bend was performed for the worst case flow problem. This analysis, along with other calculations associated with the primary containment system, is included in Appendix C. Figure 19 is a schematic diagram of the flow forces at the pipe bend.



**Figure 20. Hg axial flow force analysis.**

Results of this analysis gave a resultant force of 2kN (450 lbf) in the +X direction, which would tend to separate the nozzle flange from the jet chamber flange if the entire Hg flow path were rigidly constructed. However, the flexible hoses on both the supply and return

flows will be more compliant than the flange interface, so the possibility of leakage due to this separating force is minimal. Movement of the entire target module due to the flow force is of more concern from an alignment standpoint, and testing at ORNL will determine whether physical restraints are needed.

### 3.4 Secondary Containment

The secondary containment portion of the Hg delivery system surrounds the primary containment and prevents any leaks of liquid Hg or Hg vapors from escaping into the TT2A tunnel during operations. Shown in Figure 21, it is comprised of the following components:

- SS box housing the syringe cylinders and sump tank,
- Lexan cover with gasket,
- SS circular sleeve covering the jet chamber and optical diagnostics,
- Flexible SS duct connecting the sleeve to the box,
- Target module support structure used during shipping and handling,
- Two double beam windows with provisions for leakage monitoring,
- Multiple ports to allow access to the interior volume for hydraulic fluid, Hg fill & drain, and sensors,
- Filtration systems to trap Hg vapors.

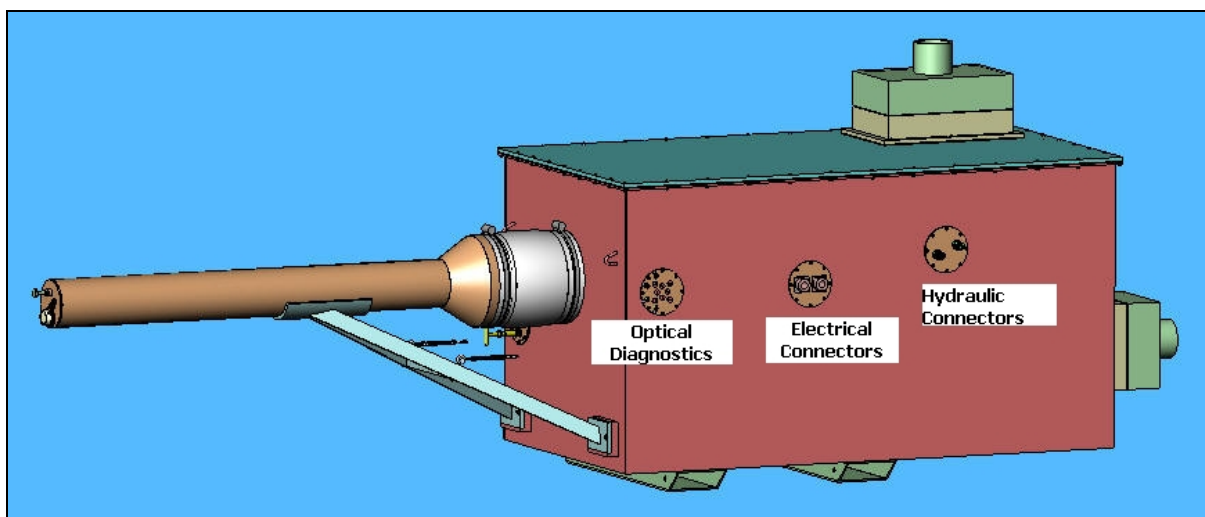


Figure 21. Secondary containment left side.

There are several ports into the secondary containment box. Each port cover flange utilizes a gasket to seal against the exterior of the box. The various flanges are shown in Figure 21 and Figure 22, and their functionality is as follows:

- Hydraulic: two quick-disconnects for the hydraulic fluid supply and return hoses.
- Electrical: two Amphenol<sup>®</sup> connectors for multi-conductor cables used for syringe and environment sensors.
- Optics: multiple optical fibers (light sources and receivers) for up to four view ports.
- Hg drain: manual valve and quick-disconnect used to extract Hg from the delivery system without opening the secondary containment. An external pump will be used to



extract the Hg. As mentioned in section 3.3, the Hg drain port is exposed to full cylinder pressure during each jet formation. The manual valve serves as a protecting device so that the quick-disconnect is isolated from these pressure pulses; during system installation this valve will be wire-tied in the closed position. It should be noted that with a special connecting plug installed, the quick-disconnect is also rated to accommodate full cylinder pressure.

- Hg fill: quick-disconnect used to load Hg into the sump tank without opening the secondary containment.
- Emergency Hg extraction: quick-disconnect with rigid tubing into small sump within the secondary containment. Should a major breach of the primary containment occur, Hg will collect in this sump and can be removed using an external pump.
- Hg vapor filters: two filter assemblies consisting of sulfur-impregnated charcoal and HEPA filters, along with a port for attaching an external ventilation system. Normally the ports will be capped; however, should an event occur such that elevated Hg vapor levels are observed, these ports can be used to remove the vapors from the containment. Having two ports allows one to be used as a fresh air inlet while vapors are extracted from the other. It also provides a mechanism to change filters.

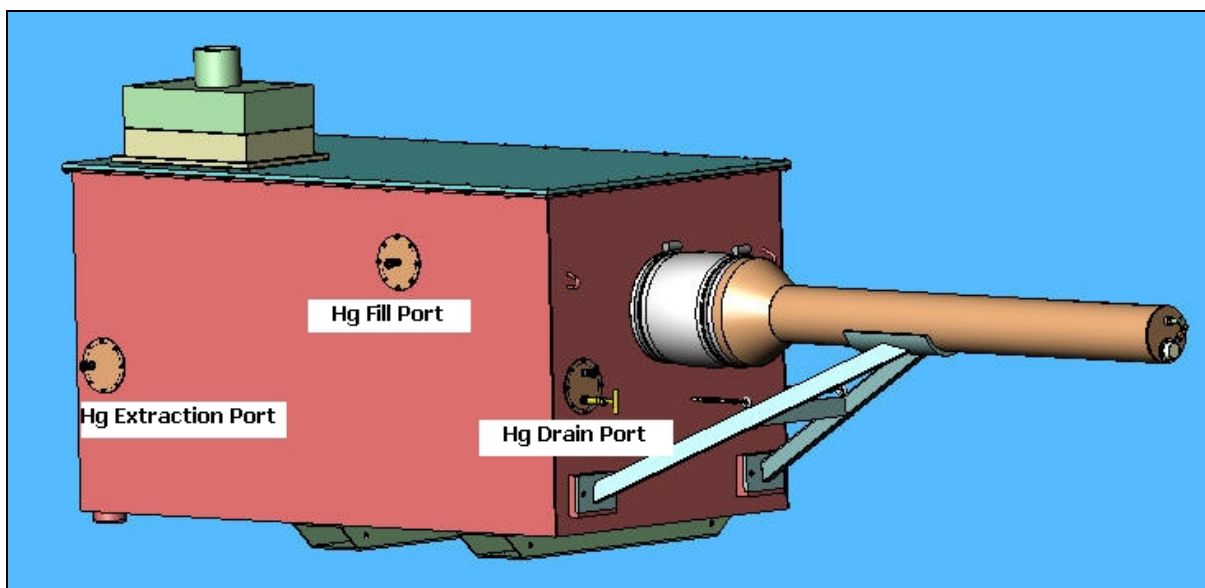


Figure 22. Secondary containment right side.

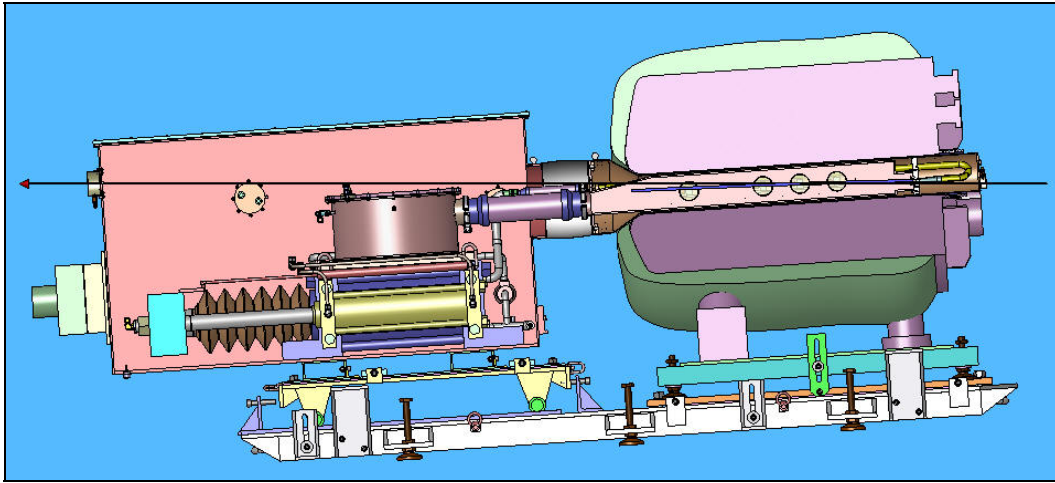
During Hg fill and drain operations, precautions will be taken to contain any leakage from making or breaking the quick-disconnect connections. This may consist of using wipes or containers during the connection or disconnection process.

The secondary containment box incorporates two stainless steel rectangular tubes that support the system when sitting on the transport cart and are also used for rigging. Nylon straps can be inserted through the tubes for lifting the assembly, and spreaders for the top of the box will be provided that prevent damage to the straps and to the sides of the enclosure.

Analyses and documentation for the secondary containment are included in Appendix D.

### 3.5 Baseplate Support Structures

As shown in Figure 2, the baseline geometry for the MERIT experiment requires that the magnetic axis be tilted with respect to the horizontal proton beam and that the solenoid center be in the beam path. Positioning the solenoid to meet these requirements dictates the need for a support structure. The integration of the solenoid with the Hg delivery system suggested that a common support structure be used to allow the assembled equipment to be handled as a single unit. Figure 23 shows the integrated equipment relative to the proton beam.



**Figure 23. Solenoid and Hg system on common baseplate.**

Multiple structures are used to transport and support the solenoid and Hg delivery system during the installation and assembly. These are shown in Figure 24 and are described below. Design of these structures was made using weight estimates of 53 kN (12 tons) for the solenoid and 17.8 kN (2 tons) for the Hg delivery system loaded with mercury.

It should be noted that several analyses were performed during the design of the support structures. Some of these are mentioned in this section, but the complete analyses are included in Appendix E.

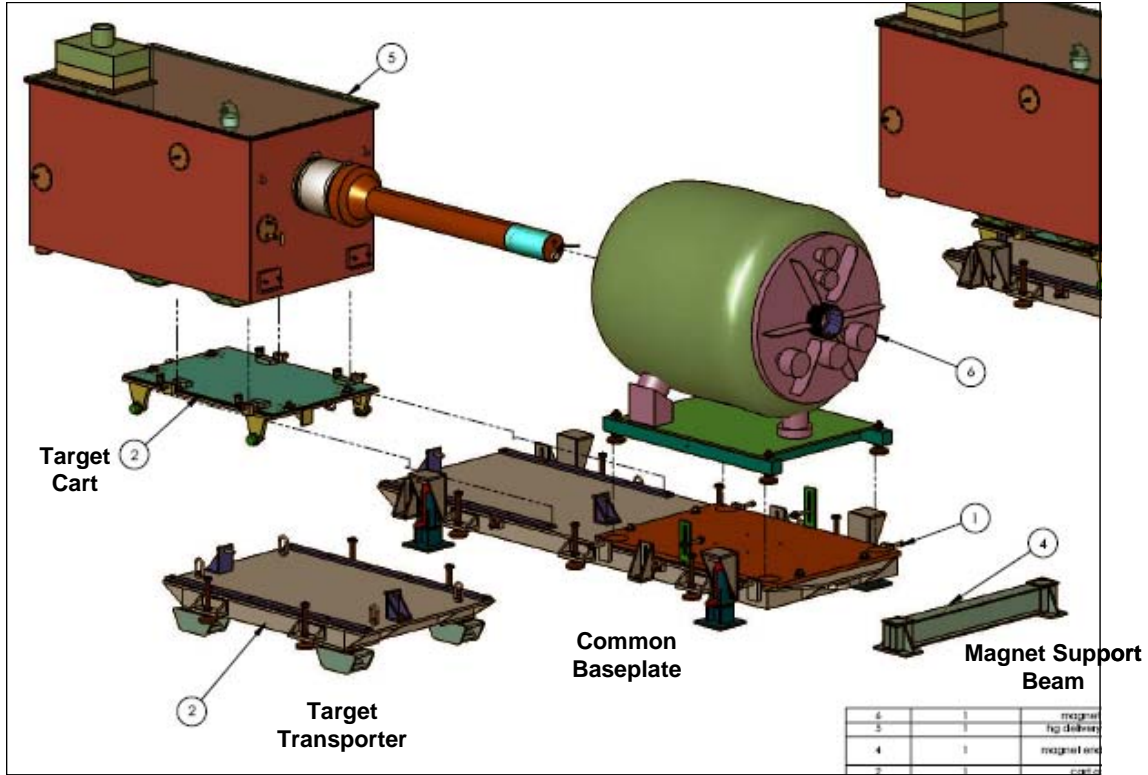


Figure 24. Baseplate support structures design drawing.

Common Baseplate

The common baseplate shown in Figure 25 is the primary experiment support structure, holding the Hg system and the solenoid in the correct tilt and elevation for the duration of the experiment. It also is designed to serve as the mobility platform for the solenoid within the CERN tunnels. *It is imperative to note that although the common baseplate has built-in lift points, these are designed to carry only the baseplate itself. Under no circumstances should the baseplate be hoisted using these lift points while supporting either the solenoid or the Hg system!* The lift points are removable; this may provide a means of operationally preventing inadvertent usage, along with appropriate labeling.



**Figure 25. Common baseplate and support beam.**

The common baseplate incorporates several design features and functions:

- Jack brackets: four detachable brackets used with hydraulic jacks to lift a loaded baseplate (with Hg system and solenoid on board). These are separate from the built-in lift points, which are side-mounted swivel hoist rings.
- Anchor brackets: four adjustable brackets that can be used with concrete anchor bolts to fasten the baseplate to the floor.
- Levelers: six threaded leveling jacks that provide fine elevation/tilt adjustment of a loaded baseplate. These levelers support the weight of the baseplate during the experiment.
- Rails: two stainless steel roller guides attached to the baseplate that allow the target cart to be transferred from the transporter to the common baseplate during target module insertion.
- Solenoid restraint brackets: two adjustable brackets which affix the magnet to the support plate upon which it sits.
- Cart positioning brackets: two brackets with jack bolts that hold the target cart in a fixed axial position during operations. Can also be used to provide fine axial positioning adjustment.
- Solenoid lateral positioning: two jack bolts on each side provide lateral position adjustment of the solenoid by sliding the magnet support plate over a low-friction surface.
- Tow hooks: one on each end used to maneuver the baseplate.

- Roller pads: three pads provide a means to set the baseplate onto high-capacity rollers during baseplate transport and gross positioning operations.

Due to the heavy weights that must be supported by the common baseplate, several stress analyses were performed to simulate various loading scenarios. In addition, analyses of certain critical welds were performed. The results of some of the analyses are shown below.

A basic analysis was performed to simulate the loading condition in which a loaded baseplate is supported by three rollers, as may occur during initial beam alignment operations. Results are shown in Figure 26. The resulting safety factor distribution on one of the outer channels is shown in Figure 27.

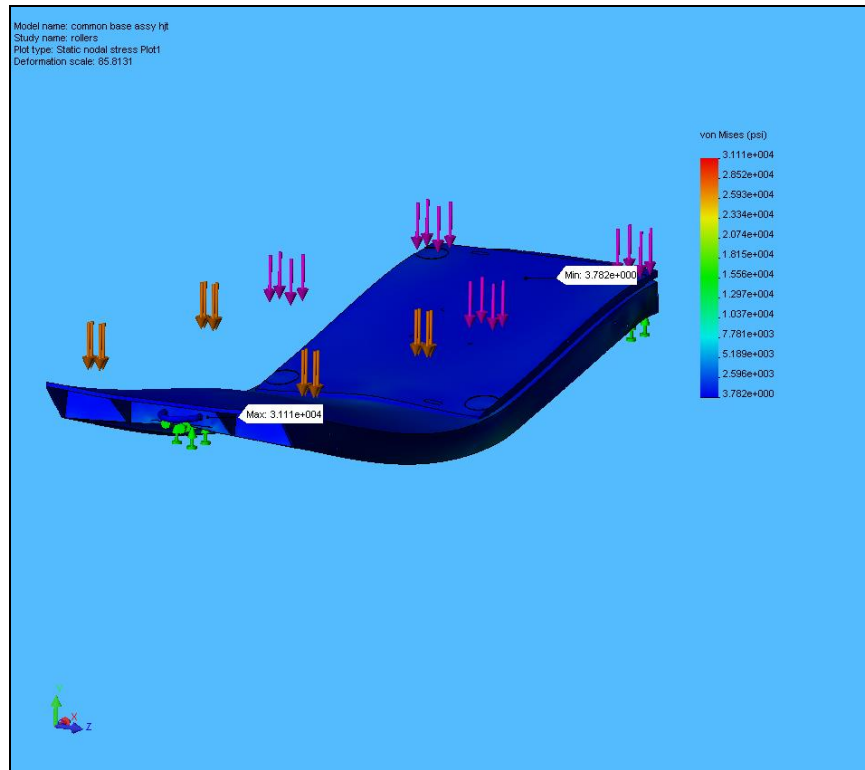
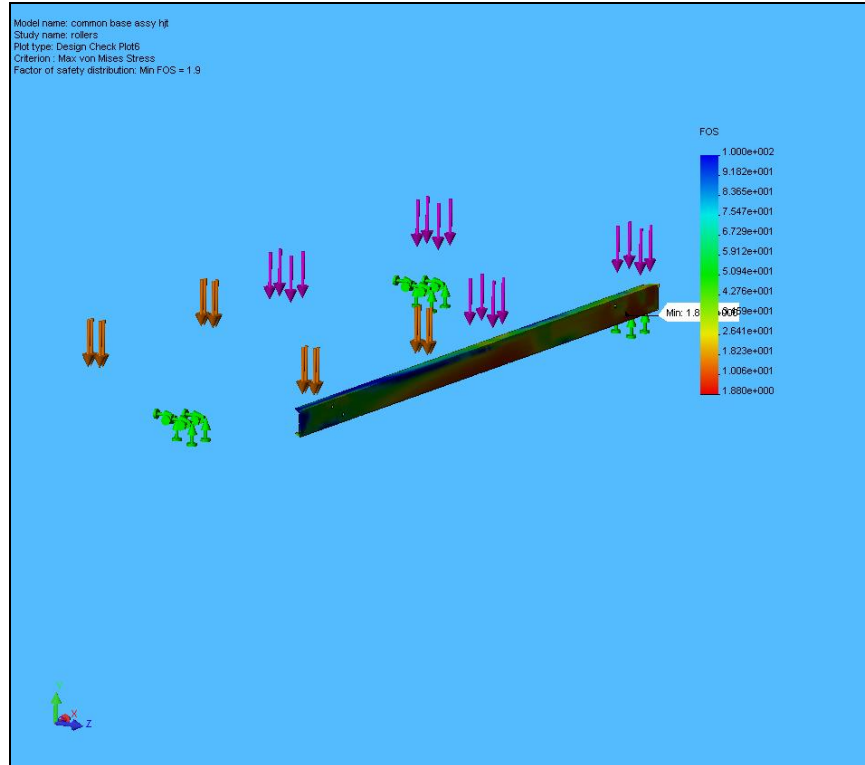


Figure 26. Induced stresses of baseplate on three rollers.



**Figure 27. Safety factor distribution for outer baseplate channel on three rollers.**

In this analysis the minimum calculated safety factor was 1.9, which is less than the desired safety factor of 3. However, the region of high stress was localized to small areas around bolt holes and was not indicative of general levels of high stress. Just outside these localized areas, the safety factor increased to 10 or more, so the structure was considered adequate for the loading condition.

This type of result was also obtained when simulating the baseplate supported by four of the six levelers. Localized areas of high stresses were calculated near bolt holes, but overall stress levels were much lower. These localized stresses will tend to relieve themselves by locally deforming and are not considered to be a structural issue. In addition, load testing on the baseplate will be performed to ensure its load-carrying capacity.

For the loading case in which the loaded baseplate is supported by the four hydraulic jacks, the jacking bracket weldment was analyzed separately since the load is carried through this bracket. In this loading condition, the worst case is for those two brackets which are under the magnet; these brackets were estimated to carry 26.6kN (6000 lbf) each, evenly loaded on the two bolt holes. Results are shown in Figure 28, with a minimum calculated safety factor of 1.4 in localized regions around the bolt holes; the safety factor quickly increases to levels above 10 just outside the holes. Welds on this bracket were analyzed separately, and the analysis gave a safety factor > 9.

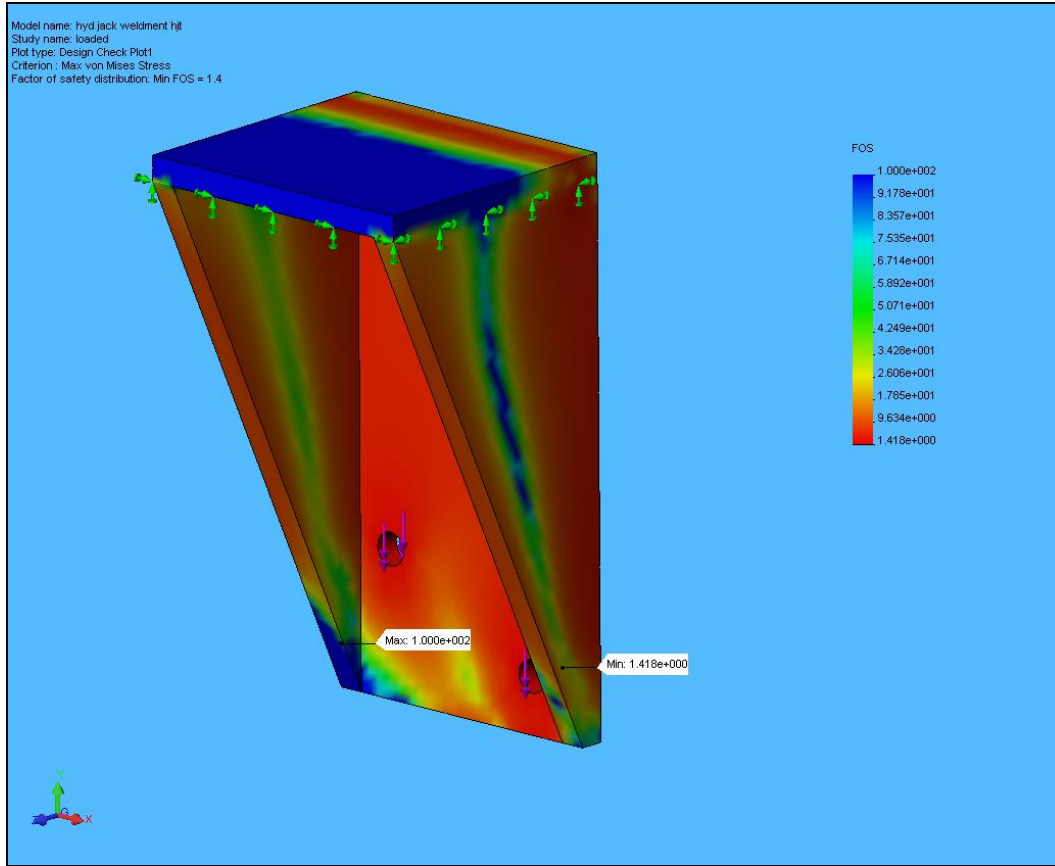


Figure 28. Safety factor distribution for the jacking bracket weldment.

### Target Transporter

The target transporter is used to move the Hg delivery system and target cart within the TT2 and TT2A tunnels and shares its basic design with the common baseplate. Temporary rollers provide the structure's mobility, and levelers are used as height adjusters and supports. Swivel hoist rings allow for lifting of the *unloaded* transporter, and tow hooks are available on each end. The transporter and cart are shown in Figure 29.

As the transporter framework matches that of the common baseplate except in length and the total load on the transporter is much less than the common baseplate, a separate analysis of the transporter frame was not performed.



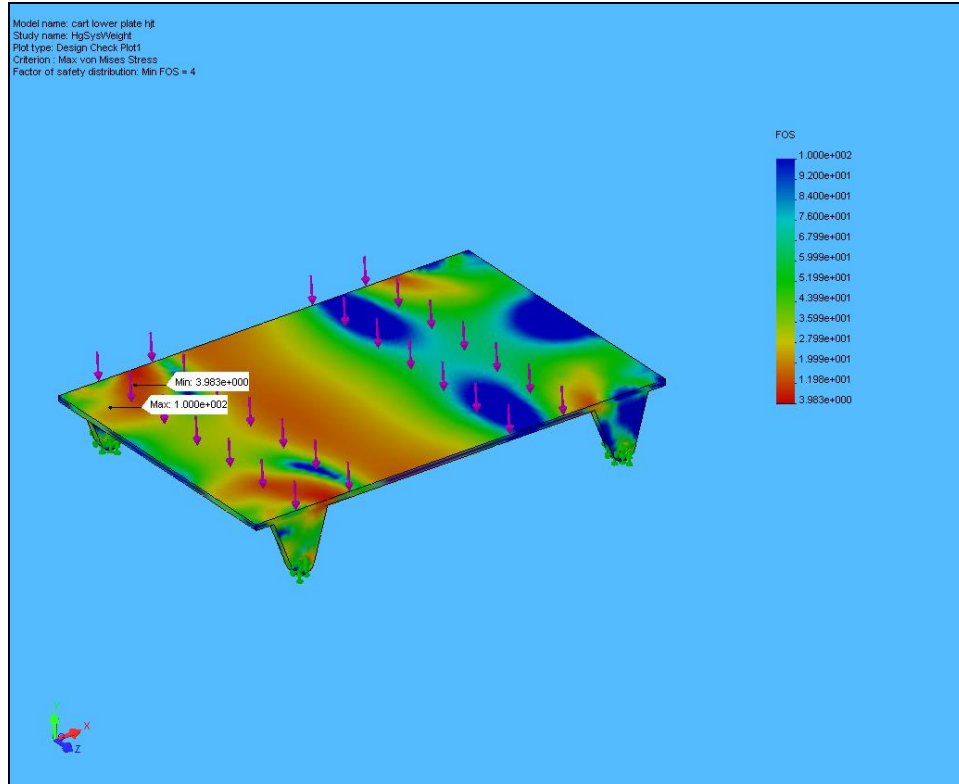
**Figure 29. Target cart and supporting transporter.**

### Target Cart

This component carries the weight of the Hg delivery system and allows it to transfer from the transporter frame to the common baseplate while inserting the target module into the bore of the solenoid. Primary material is aluminum. The cart incorporates the same lateral position adjustment system as the common baseplate, so the Hg system can be horizontally shifted with the solenoid for precise alignment with the beam. No vertical positioning adjustment is available; it is assumed the flexible components of the target module will accommodate minor vertical misalignment with the solenoid bore and that the leveling screws on the magnet can be used for final adjustment.

A finite element analysis was made of the primary cart structure. Results are shown in Figure 30 and indicate the cart is capable of supporting the full weight of the Hg system with a minimum FOS of four.





**Figure 30. Safety factor distribution for the cart structure.**

### Magnet Support Beam

The common baseplate uses threaded levelers to support the weight of the system. To position the magnet center in the beamline, however, requires one pair of levelers to extend close to their upper limit, and in this situation stability is a concern. To eliminate this concern, a separate structural support beam was designed to take up most of the space (approximately 15-cm) and allow the levelers to be near their lower limit. The aluminum beam structure will be inserted under the baseplate while it is being supported with the lifting jacks.

A structural analysis was made of the beam, and the results are shown in Figure 31. The minimum FOS was calculated to be 13.

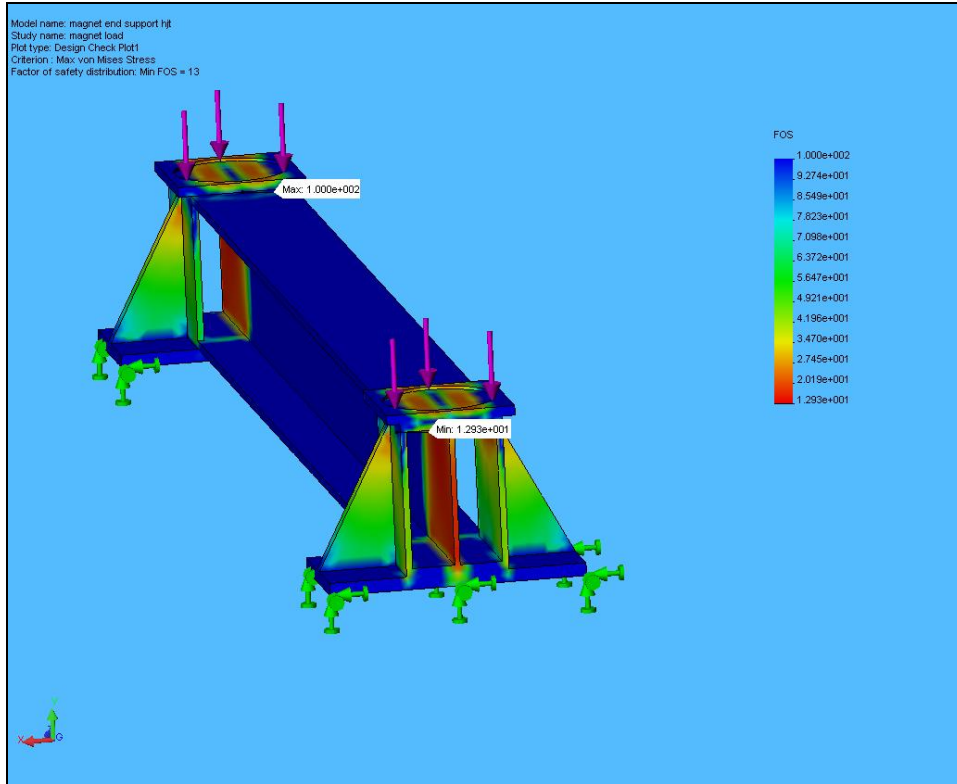


Figure 31. Safety factor distribution for solenoid support beam.

### 3.6 Control System

As mentioned in Section 3.2, the syringe pump hydraulic power unit was supplied with some minimal on-board controls so that basic syringe control was provided. This control will not be adequate for the MERIT experiment. Figure 32 shows the location of the experimental equipment in TT2A and the location of the HPU in TT2. The originally proposed location for the remote control room was the ISR tunnel, but the final location appears to be Building 272.

As system design progressed, it was noted that the control system would require a great deal of flexibility to be able to incorporate various types of sensors. Labview® was chosen as the control system software package, and it will be run on a laptop computer in the remote control room and separated from the experimental area by a great distance. It is not practical to run sensor wires over such a great distance for a short-term experiment like MERIT, so the controls approach taken was to place Labview®-compatible sensor modules inside the HPU control cabinet and communicate with them over an Ethernet network. In this approach, all the MERIT sensors terminate in the TT2 tunnel, whether they originated in TT2 or TT2A.

From a system safety viewpoint, a remote emergency stop is required that is independent of the MERIT control system. The syringe system was procured with a 76m (250ft) emergency stop pendant directly wired into the HPU power cabinet based on the original ISR control room location. Now that the final control room location greatly exceeds this distance, another means of controlling power to the HPU will be required.

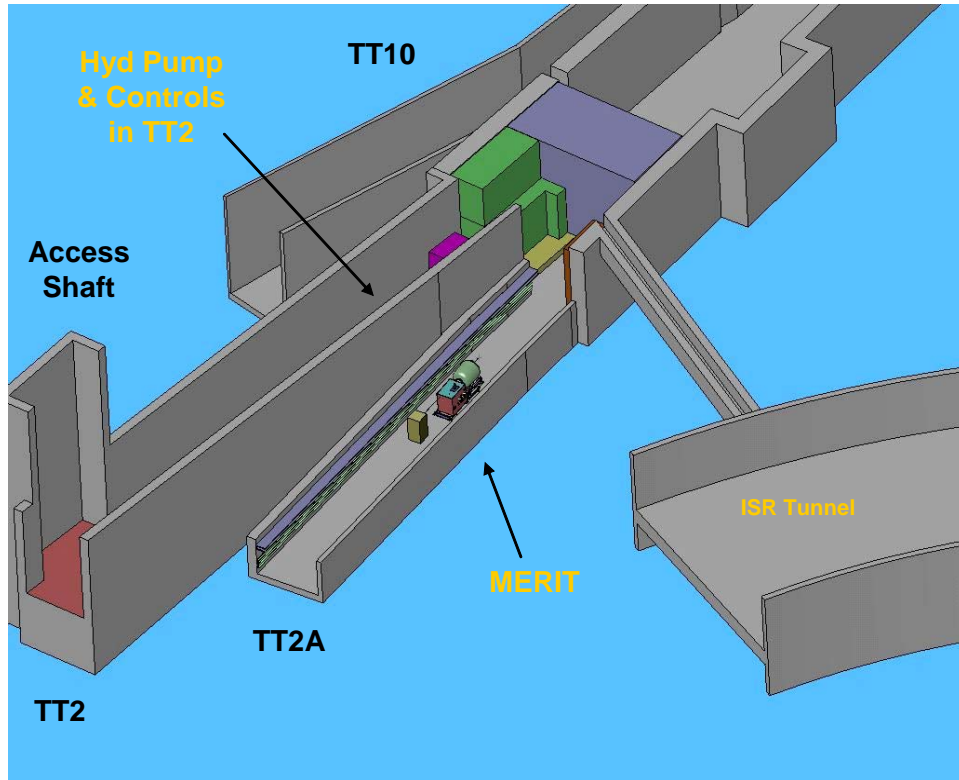


Figure 32. MERIT layout in the CERN tunnels.

The Labview-based control system is still under development, but the basic screen layout can be seen in Figure 33. The system provides the following capabilities/functions:

- Jet configuration: the velocity profile of the jet can be configured within the constraints of loaded Hg volume & available piston stroke.
- Operation: provides control of the syringe HPU. Supports manual and triggered operating modes.
- Performance: graphical representation of syringe movement & sensor feedback during operating cycle.
- Data logging: provides capability to record history file.
- Operator feedback & status messages
- Status/alarm indicators

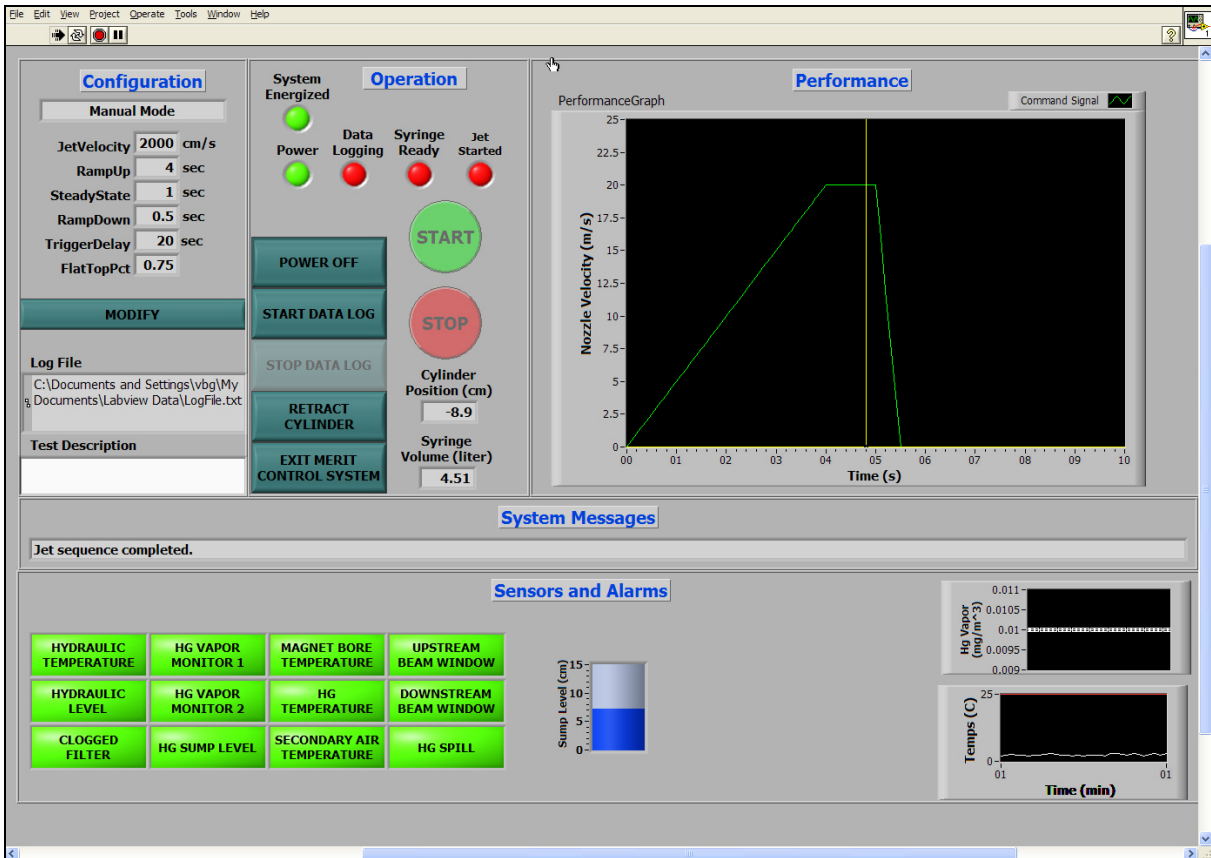


Figure 33. Labview control system operator interface

## 4.0 Operations and Testing

### 4.1 Filling and Draining Mercury

A fundamental requirement for designing the Hg delivery system was that filling and draining Hg from the system must be accomplished without opening the secondary containment. The secondary containment (enclosure) is designed with a fill-port located on a sidewall of the enclosure. The port connects directly to the sump tank as shown in Figure 34. The drain port is located at the front of the enclosure and is shown in Figure 22.

A peristaltic pump will be used to transfer mercury from standard 2-liter flasks by means of a stainless steel tube connected to flexible Tygon<sup>®</sup> tubing. (The flasks are U.S. Department Of Transportation-approved containers for transporting mercury.) Figure 35 is the actual pump that will be used for MERIT mercury transfer operations. Its use for transferring mercury was successfully demonstrated at ORNL. Appendix I contains detail information about the pump and results of mercury-transfer tests that were done in 1999 for the Spallation Neutron Source - Target Test Facility. It is important to mention that during mercury transfer operations only the inner wall of the tubing is in contact with mercury, and that the pump mechanism is never in contact with mercury. Therefore, only the tubing becomes contaminated.

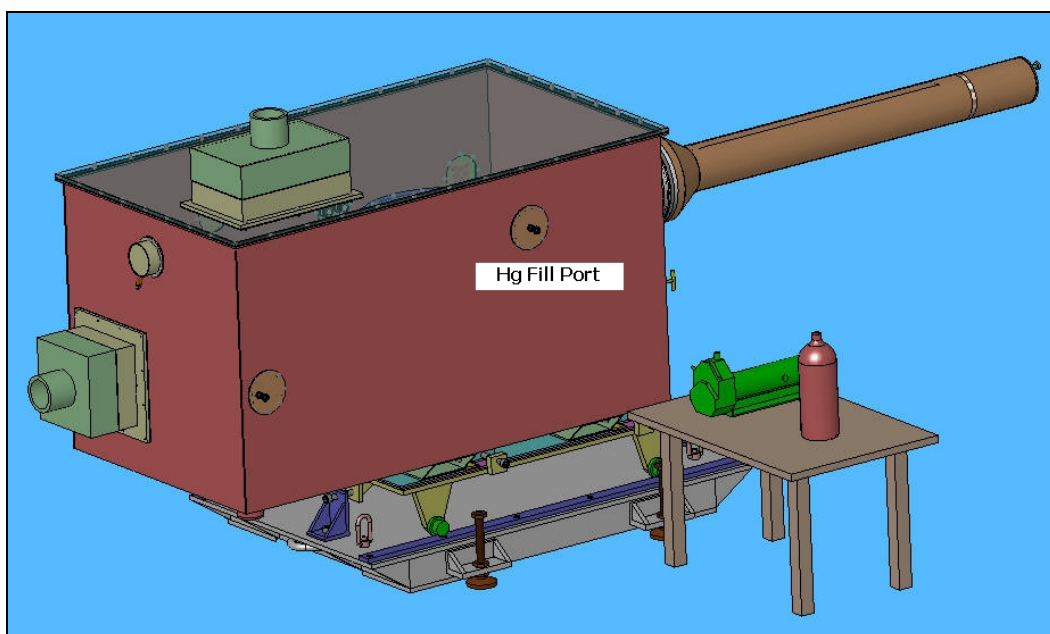


Figure 34. Mercury fill port.



**Figure 35. Peristaltic pump for transferring mercury.**

#### Mercury Fill Procedure

The procedure for transferring mercury into the sump tank is as follows:

1. Position the pump and the flask at an elevation higher than the fill port.
2. Place the pump and flask in a plastic tray lined with gauze, or provide other suitable containment for spill control.
3. Check that all of the auxiliary support equipment is in place and properly operating, namely, the digital scale, portable vapor monitor, portable snorkel, etc.; connect the Tygon<sup>®</sup> tube fitting to the fill port connector.
4. Weigh and record the flask weight; (the tare for each numbered flask will have been determined from the tests at ORNL).
5. Remove the flask plug and insert the stainless steel suction tube that is attached to the other end of the Tygon<sup>®</sup> tube; start the pump. (The pump settings will have been predetermined and preset from testing at ORNL.)
6. Siphon the mercury from the flask until the suction in the tube is lost; record the weight of the empty flask.

The air that is displaced during the fill operation, up to 23 liters, will be vented from the sump tank directly to the primary filter unit located on top of the enclosure. The air passing through the filter material will be monitored for mercury vapor as well as being collected into the portable snorkel.

Since the exact volume of mercury needed for testing at CERN will have been determined from the tests at ORNL and MIT, a careful accounting of the weight will verify the quantity of mercury installed in the target.

#### Mercury Drain Procedure

The baseline method for transferring mercury from the target will use the peristaltic pump. The pump will be connected to the quick-disconnect fitting on the secondary enclosure that leads to the sump tank drain tube. The secondary enclosure will remain closed during this operation.

An alternative method for transferring mercury out of the target will be investigated as part of the ORNL testing. This method is believed to eliminate the possibility of “over filling” a flask. The procedure is as follows:

1. Place a 3-liter clear plastic bottle, marked with a 2-liter “fill line” under the drain port. Connect a flexible tube with a quick-disconnect to the Hg drain port on the secondary enclosure.
2. Using the drain valve as a flow control device, gravity-drain two liters of mercury into the 3-liter bottle. A manual- or check-valve with a quick-disconnect fitting will be attached to the Hg fill port to allow air into the sump tank to prevent a vapor lock caused by the draining Hg.
3. Using the peristaltic pump, transfer 2-liters of mercury from the plastic bottle to a steel flask; install the flask plug and record the weight.
4. Repeat steps 2 and 3 until all mercury that can be gravity-drained from the system has been removed.
5. Remove mercury remaining in the sump tank or the drain line using the peristaltic pump.

By accounting for the weight of mercury removed from the target, an accurate estimate can be made of the volume of mercury remaining in the system. This amount must be recorded in the transportation documents for the return shipment of the target equipment to ORNL.

All waste materials that are generated such as mercury-contaminated gloves and gauze, to name two, will be double-wrapped in plastic bags, taped, and disposed of in the Satellite Accumulation Area (the 55-gal. drum listed in Table 4). Tools that may become contaminated and other reusable items for subsequent mercury handling activities will be double-wrapped in plastic bags and stored in a sealable plastic bin.

## **4.2 Mercury Vapor Filtration**

The secondary enclosure has two sulfur-impregnated charcoal filter assemblies; the larger one mounted on the top cover, the smaller one mounted on the down beam wall. These filters are an adaptation of filter used in the portable snorkel. The primary filter on the top cover measures 432 x 255 x 51 mm (17 x 10 x 2 inches) and the secondary filter on the back wall measures 267 x 267 x 38 mm (10-1/2 x 10-1/2 x 1-1/2 inches). Figure 1 shows the location of the filters. Each filter is designed to connect with the 127-mm (5-inch) diameter hose of the portable snorkel.

During routine target equipment operations each filter port remains closed so that there no exchange of the air environment between the secondary enclosure and the TT2A Tunnel. The two air environments are at pressure equilibrium as long as the temperature in the enclosure remains approximately at the temperature in the tunnel. (The temperature rise of the mercury and the air in the enclosure will be recorded between pulses during the ORNL tests.) Therefore, the air in the secondary enclosure that is under continuous monitoring for mercury vapor is isolated from the tunnel air.

Prior to installing mercury into the sump tank, the cover on the primary filter will be removed and the volume of air that is displaced from the sump tank will be “pushed” through the primary filter, and monitored for mercury vapor levels using the portable vapor monitor. If any vapor is detected, the snorkel can be attached to provide a double level of filtration to prevent mercury vapor from being pushed into the tunnel environment. The effectiveness of “single” and “double” filtration will be demonstrated as part of the testing at ORNL.

#### Filter Lifetime Estimate

An estimate of filter lifetime was made based on the calculations used for ORNL’s Target Test Facility and the data provided by the manufacturer of the filter material. The sample calculation shown below yields a lifetime of 185 hours of vapor exposure before the filter is 12% saturated.

- Flow Rate 110 cfm (through the snorkel filter)
- Temperature 25° C (vapor temperature)
- Filter Efficiency 99.0% (vendor information)
- Filter Weight 6 lbs (80% charcoal, 20% sulfur)
- Allowable Filter Saturation 12% (vendor information)
- Filter Life 185 hrs

*(Note: The calculation does not include the reduction for adsorption of humidity.)*

The following equations were used for the calculation. [5]

#### Saturation Pressure

$$\log P_{sat} = -3105.5 / T_{0K} + 4.9294 \quad (\text{bar})$$

#### Saturation Concentration

$$C_{sat} = 2.445 P_{sat} / T_{0K} \quad (\text{Kg}_{\text{Hg}}/\text{m}^3) \quad (P_{sat} \text{ mbar})$$

#### Filter Replacement Procedure

If it becomes necessary to replace either the primary filter or the secondary filter, the portable snorkel will be used to maintain a negative pressure in the secondary enclosure, while at the same time filtering the extracted air. The procedure for replacing the primary filter is



described below for a routine operation where the secondary enclosure vapor monitor shows no indication of vapors. The actual procedure will be demonstrated as part of the testing at ORNL.

1. The operator will be dressed with proper personal protection equipment (PPE); the assistant operator will handle the portable vapor monitor.
2. Connect the snorkel hose to the secondary filter port; turn on the snorkel to achieve a low flow rate, i.e., 280 liters/min (5-10 cfm).
3. Remove the 5-inch diameter cover from the primary filter to permit an inflow of air into the secondary enclosure.
4. Remove the filter pack assembly and increase the snorkel flow rate to a level to be determined during ORNL testing; continue monitoring for vapor in the vicinity of the filter. Place the filter in a plastic bag and seal the bag.
5. Install a new filter; decrease the flow to the snorkel to zero and cover the primary port.

The same procedure will be used for replacing the secondary filter except in step 2, the snorkel hose will be connected to the primary filter port.

### 4.3 Off-Normal Conditions

Several off-normal conditions were postulated and are discussed below. Two of these would impact the operations of the target system: the first is measurable vapor in the secondary enclosure, the second is a spill from the primary enclosure into the secondary enclosure but contained in the secondary. The others conditions were factored into the system design and are not thought of in the context of operations.

#### Vapor Leak Into Secondary Containment

The secondary containment is continuously monitored for mercury vapor. A Jerome 431-X monitor located in the adjacent tunnel (TT2) samples the containment volume every 5 minutes through a flexible tube. Through its interface with the Labview® control system, it will send a visual and audible signal if the threshold limit values (TLV's) for vapor has been reached. The system will be configured to match the threshold setting used for the Target Test Facility (0.0125 mg/m<sup>3</sup>), and can easily be changed to meet other levels. The following TLV's are the current U.S. and ORNL standards.

-OSHA TLV: 0.050 mg/m<sup>3</sup> for up to a 10 hour work day, 40 hours per week

-ORNL TLV: 0.025 mg/m<sup>3</sup>

-TTF action level (when respirators are required): 0.0125 mg/m<sup>3</sup>

Upon receiving an alarm signal, the operator will check the conductivity probe sensor for indications of a major leak from the primary containment, the secondary vapor monitor in the tunnel. If there is a zero-reading from the conductivity probe, and the other sensors including the secondary vapor monitor are sending normal signals, it may be concluded that: a) there is a minor leak from the primary containment, or b) the vapor monitor sent a false-positive signal.

To verify if the monitor is functioning properly, the spare (portable) sensor will be exchanged with the monitor in tunnel TT2, where immediate personnel access is possible. Regardless of the outcome of the monitor test, operations may continue until the end of a shift. At that time, a decision will be made to make a visual inspection of the system. According to Table 3, the dose rate at the top of the secondary enclosure, at shutdown (or immediately thereafter) will be  $<1$  mrem/h, and will be low enough for visual inspection.

While this inspection is occurring in TT2, the vapor monitor located in the tunnel (TT2A) near the target equipment will be checked for indications of vapor. If vapor is present only in the secondary enclosure it will remain contained unless there is a break in the enclosure, or leakage from one or both of the enclosure filters. The portable monitor will be used to check for any of these possible occurrences, if vapor was detected in the tunnel. If the tunnel does not contain vapor, and there is only evidence of vapor leakage into the secondary enclosure, i.e., no elemental mercury in the enclosure sump, it is assumed that operations will resume.

#### Mercury Leak Into Secondary Containment

Although highly unlikely, if elemental mercury is detected in the secondary enclosure by the conductivity probe or by visual inspection, there will be no doubt that the integrity of the primary containment was breached. Based on the operations requirement that the primary containment shall not be opened during the lifetime of the experiment at CERN, test operations will cease and a cool down period of up to one month will commence. According to Table 3, the mercury after that cool down period will have a contact dose of  $<10^{-2}$  mSv/h ( $<1$  mrem/h), low enough to extract Hg from the target and refill the mercury flasks.

The target, being a double contained system is designed so that unloading mercury can be accomplished without opening the secondary containment. Hence, the vapor will remain contained as long as the secondary enclosure is not opened. The (activated) mercury will be removed from the syringe pump system in the same manner described in Section 4.1, with the exception that Health Physics surveillance and oversight will be required because of the activation of the mercury.

#### System Overpressure

The mercury delivery system is an open system, and only by having a blockage at the nozzle it would be possible to over-pressurize the equipment. While no practical method of totally blocking the Hg is envisioned, if a total blockage should somehow occur, the Hg channel would become a static pressure system and hydraulic system pressure could increase above its nominal level of 200 bar (3000 psi). However, the hydraulic pump has a built-in relief valve pre-set at 220 bar (3200 psi). Upon reaching the relief setting, hydraulic fluid would be diverted directly from the pump back into the reservoir thereby preventing an over-pressure condition in either the hydraulic or Hg fluid systems.

#### Power Failure

A loss of electrical power to the Hg delivery system (or emergency stop) will immediately shut down the hydraulic pump and thus the movement of the syringe pistons. It may be possible that this could cause a “water hammer” shock effect in the flow loop if a portion of the Hg flow becomes separated. This will be investigated as part of the ORNL tests.

Loss of Network Connectivity

The Labview® hardware has an internal system controller that provides network connectivity to the laptop computer. That connectivity includes the provision for a "watchdog" timer to detect loss of communication. Should such loss occur, the hardware controller will be configured to power down the hydraulic pump and return the system to an inoperable state.

**4.4 Equipment for Mercury Handling**

A kit consisting of miscellaneous small tools, cleanup materials, various plastic containers, and personal protection equipment (PPE), will travel with the target system to MIT and CERN. The kit will provide self-sufficiency for all activities that deal with the target equipment and mercury handling, including installation, equipment check out, spill control, and cleanup. Table 6 is a listing of the equipment that will be available for use to support target operations.

**Table 6. Miscellaneous Experiment Support Equipment.**

<b>Item</b>	<b>Comments</b>
Vacuum Cleaner - Tiger Vac®	At Princeton; will be sent to MIT
Portable Snorkel - Scavenger®	At Princeton; will be sent to ORNL
Spare Filters	Sulfur impregnated charcoal & HEPA at Princeton; will be sent to ORNL
Vapor Monitor	Procurement by Princeton
Vapor Monitor Calibration Kit	Procurement by Princeton
55-gal. Drum	Satellite Accumulation Area (SAA)
Plastic Sheeting - roll	Heavy gauge plastic sheeting - 10-ft. wide
Peristaltic Pump	Available from ORNL
Tygon Tubing	
Hg Flasks (qty. TBD)	U.S. Dept. of Transportation approved; standard 76-lb. steel flask
Merc-X Cleaning Solvent	
Sponges	
Plastic Buckets	
Plastic Pans	
Teflon Tape (yellow)	Sealing flasks; yellow tape is more durable than white
Gauze - roll	
Small Tools	Wrenches, screwdrivers, ...
Bungee Cords	Assorted lengths
Vinyl Tape	Yellow, 4 rolls
Plastic Bags	Assorted sizes - 1 gal. to 20 gal.
Plastic Bottles	1-, 2-, 3-liter sizes - 4 of each required
Lab Coats	
Shoe Covers	
Safety Glasses	
Ear Plugs	
Tyvek Hooded Suits	
Nitrile Gloves	
Full Face Mask w/ Hg Cartridges	
Miniature Aspirator Pump	Used to collect small quantities of mercury

Item	Comments
Flashlights	
Swagelok Quick Disconnect Fittings	
Scale	Digital - weighing Hg
Hand Pump	Transfer hydraulic fluid
Plastic Bin - 50 gal.	Storage chests for misc. equip. - 2 required
Berm Material	30-ft. required

#### 4.5 Equipment Maintenance

There is virtually no scheduled maintenance for the target system, except for routine visual inspections, checking performance of the various sensors, and testing the control system for emergency stop operations.

The target system will be assembled initially “hands on” without restriction except for safe mercury handling protocol. Thereafter, the target will be maintained and operated with minimal personal contact after beam operations commence in order to achieve as low as reasonably acceptable (ALARA) exposure to the operators. With this in mind, the design for the target system incorporated the use of dripless quick-disconnect connections, and fasteners and hardware suitable for minimizing handling time and the need for subsequent maintenance.

## 5.0 Facility Interfaces

### 5.1 Electrical

The Hg delivery system will require a 30kW power supply, 480VAC/3PH/60Hz for operation at MIT and 360VAC/3PH/50Hz for operation at CERN. In addition, the power source will require a means to be de-energized from the MERIT control room should an off-normal condition occur.

### 5.2 Ethernet

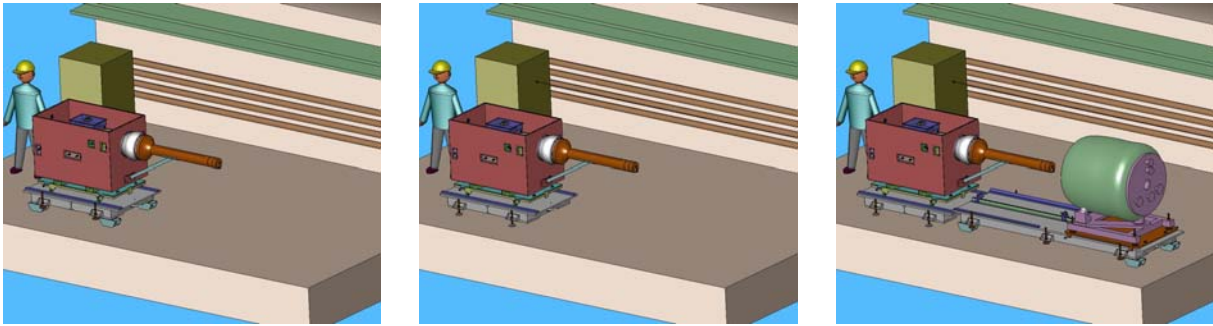
Hg system control requires network wiring between the remote control room and the hydraulic power unit in the TT2A tunnel. A dedicated network is preferred, but access using CERN's standard network may be acceptable if permitted by CERN network policies.

### 5.3 Target Equipment Installation

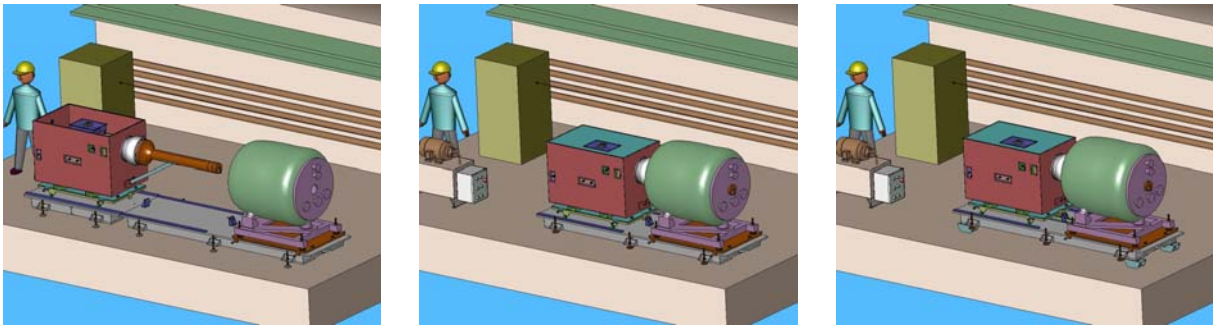
The target equipment is designed for handling by fork lift or crane. The intended sequence for getting the equipment into TT2A is as follows: After the target is lowered into tunnel TT2 from ground level, it will be moved along the down-slope of the tunnel using the CERN "turtle." The target is configured so that it can make the turn into tunnel TT2A, mounted on the transfer cart. Figure 36 and Figure 37 show the sequence for installing the target and the solenoid.

1. Lower the target transporter (using built-in swivel hoist rings) onto a horizontal surface (wedge) sitting on the TT2 sloped floor. Use one of the built-in tow hooks to attach the transporter to the CERN "turtle" or other fixed object.
2. Lower the Hg system with attached target cart (using straps through the tubes under the secondary containment) onto the target transporter.
3. Using the turtle, pull the system off the wedge, remove the wedge, then move the system into TT2A.
4. Lower the common baseplate (using built-in swivel hoist rings) onto the wedge. Use one of the built-in tow hooks to attach the baseplate to the turtle or other fixed object.
5. Lower the solenoid onto the common baseplate.
6. Using the turtle, pull the system off the wedge, remove the wedge, then move the system into TT2A.
7. Lower the hydraulic power unit (using built-in lift points) onto the wedge. Attach to the turtle or other fixed object.
8. Using the turtle, pull the power unit off the wedge, remove the wedge, then move the system into position within TT2.

Once the MERIT equipment is positioned in the TT2A tunnel, Figure 36 and Figure 37 show the sequence for inserting the Hg system into the solenoid.



**Figure 36. Target equipment moving into TT2A.**



**Figure 37. Target equipment inserted into solenoid.**

Mercury will be loaded as described in Section 4.1 after the target is in position in the beam line.

## 6.0 Packing and Transportation

The ORNL Transportation Group has been consulted during the past six-months to ensure that the target equipment design meets the criteria for truck shipment to MIT, shipment to CERN in a short sealand container 2.4-m wide x 2.4-m high x 6.1-m long (8ft x 8ft x 20ft), and the return shipment of mildly activated components back to ORNL. In addition, meetings with environmental, safety, and health (ES&H) personnel to ensure that ES&H criteria were being met.

After completion of the ORNL tests, the mercury will be removed from the target and put back into the standard 2-liter shipping flasks. The target system and all related equipment will be sent to MIT via a dedicated truck for integrated system tests. Upon completing those tests, the target system and the solenoid will be shipped to ORNL, where the equipment will be loaded into a certified sealand container. The ORNL Transportation Group will prepare the necessary documents for international shipping and make arrangements for truck transport to a local seaport, trans-Atlantic surface shipping, and truck transport to CERN. It is presumed that CERN will make similar arrangements for the return shipment of equipment to ORNL. Figure 38 is a layout of the sealand container showing the target equipment and the solenoid. (Note that this is a first draft and is not an optimized arrangement.)

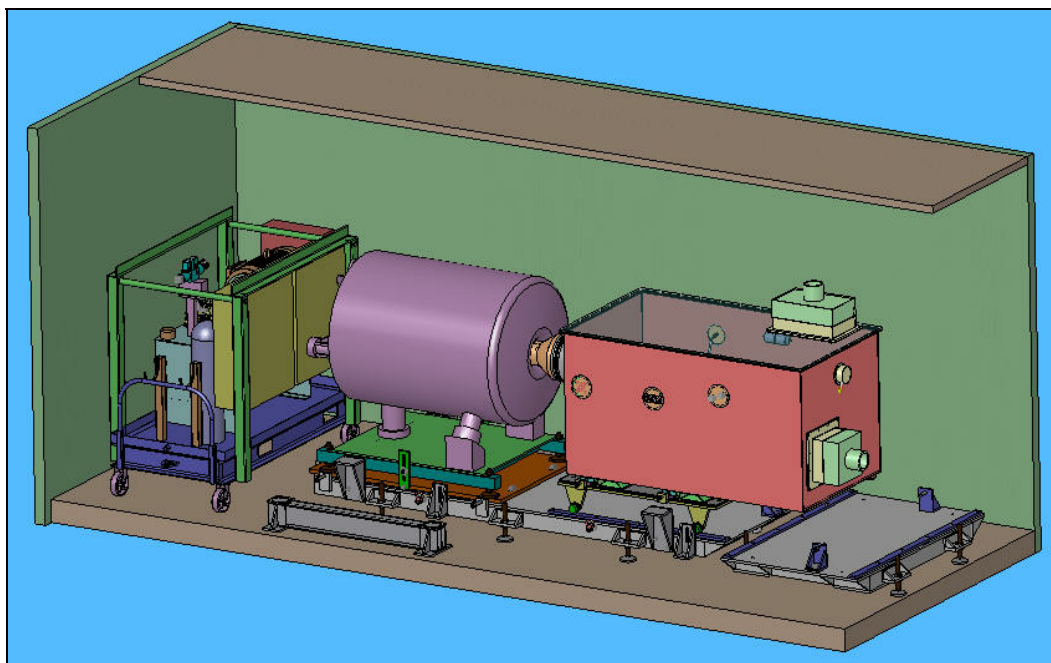


Figure 38. Target equipment and solenoid inside a short sealand container.

## 7.0 Equipment Decommissioning and Disposition

After completing the testing at CERN, it is presumed that the target/solenoid equipment will remain undisturbed for several weeks so that the inventory of mercury will cool to a dose rate approaching  $<10^{-2}$  mSv/h (1.0 mrem/h). The mercury will then be removed from the target and stored in steel flasks. Then, the target/solenoid will be moved out of the beam line and left in tunnel TT2A for additional time. After another 2-4 weeks, virtually all components will have a dose rate that is low enough ( $10^{-4}$  mSv/h — 0.01 mrem/h), to permit unlimited handling for radiation-trained workers.

At that time, the target can be removed from the solenoid, and all equipment can be brought to ground level for placement into the sealand container. The original packing materials and crates will be reused, and presumably the CERN Transportation Group will make arrangements for the return shipment to ORNL.



## 8.0 References

1. “MERIT Experiment Window Study – Proton Beam Windows – Optical Windows,” N. Simos – Brookhaven National Laboratory; presented at the BNL Collaboration Meeting, December 12, 2005.
2. “Solenoid Field Map.txt,” H. Kirk – Brookhaven National Laboratory; September 21, 2004.
3. “MARS Simulation of the Mercury Target Experiment,” Sergei Striganov - Fermi National Laboratory; presented at the MIT Collaboration Meeting, October 18, 2005.
4. “Sapphire Window Impact Test,” K. McDonald, H.-J. Park, Princeton University, January 26, 2006. <http://www.hep.princeton.edu/~mcdonald/mumu/target/>
5. Quecksilber und seine Gefahren, Swiss government worker safety report, SBA No. 145, Luzern.