

Overview of Solid Target Studies for a Neutrino Factory

Rob Edgecock¹, Roger Bennett¹, Goran Skoro², John Back³, Stephen Brooks¹, Chris Booth²

¹Rutherford Appleton Laboratory, ²University of Sheffield, ³University of Warwick United Kingdom

Neutrino Factory Target Concepts

Parameters of the Neutrino Factory Target

Proton Beam
 pulsed 50 Hz
 bunches 3 (2 ns rms)
 energy 10 GeV
 beam power 4 MW

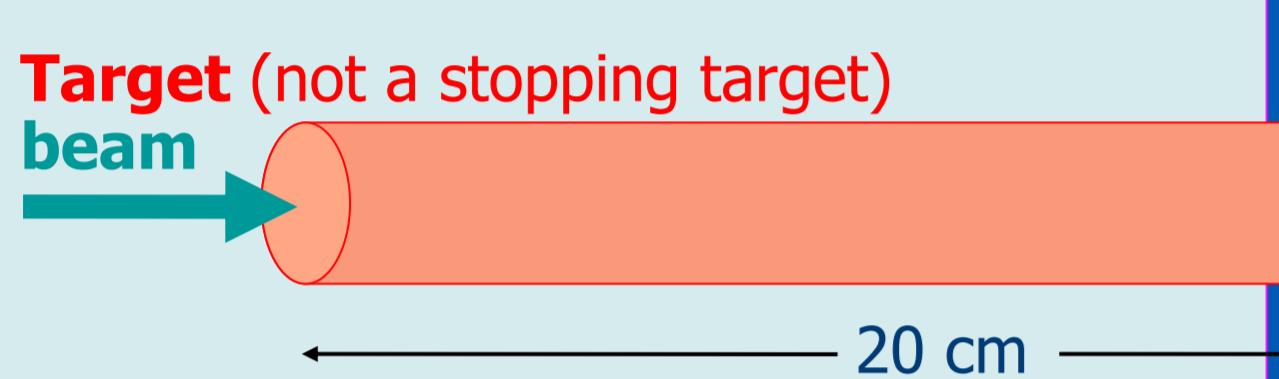
Target (not a stopping target)
 beam → 

mean power dissipation 0.75 MW
 energy density ~ 300 J/cm³

The target operates at very high mean power dissipation and extremely high energy density. This high power density creates severe problems in dissipating the heat and the short pulses produce thermal shocks due to the rapid expansion of the target material. These shocks can potentially exceed the mechanical strength of solid materials.

In addition, the pions and muons created in the target must be collected in a 20 Tesla solenoidal field.

This imposes strong restraints on the target and collector system which must ultimately be designed as a single entity.

Several targets which potentially can withstand the huge power density are currently being considered worldwide:

- Mercury (or a liquid metal) jets
- Contained flowing mercury (or a liquid metal)
- Solid target – tungsten or tantalum bars
- Granular solid target

Solid Target Options

The UK is currently investigating solid targets. The solid target is simple in concept, but may be susceptible to **shock damage**. There are many examples of solids bombarded by proton beams at similar power densities and even targets operating at an order of magnitude higher power density have been shown to survive many pulses.

We have studied different options for Neutrino Factory target and almost all of them are based on the idea to have a number of individual (tungsten or tantalum) bars where a "new" bar would be presented for each beam pulse. The most interesting concept is a spokeless wheel with around 150 tungsten bars. In this case solenoid must be split (Helmholtz coil).

Wheel option has been already used at PSI... and spokeless wheel in some amusement parks

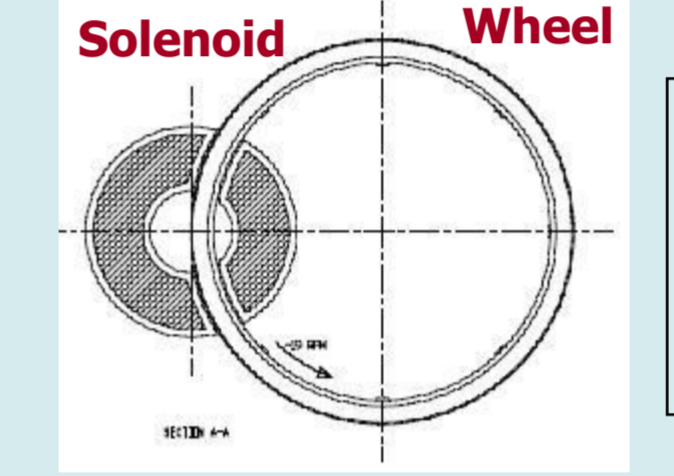

Dimensions
 Outer diameter: 5 m
 Speed at rim: 5 m/s
 Revolution time: 3.14 s
 Target spacing: 100 mm
 # of targets: 157

Details
 Outer "target" rim
 BEAM
 Thermal isolation
 Inner "guide/driver" rim

Pion yield
 Average pion yield per proton (%)
 Line: Mercury jet yield (Study II geometry)
 Accepted yields for the solid tungsten target (1cm diameter)

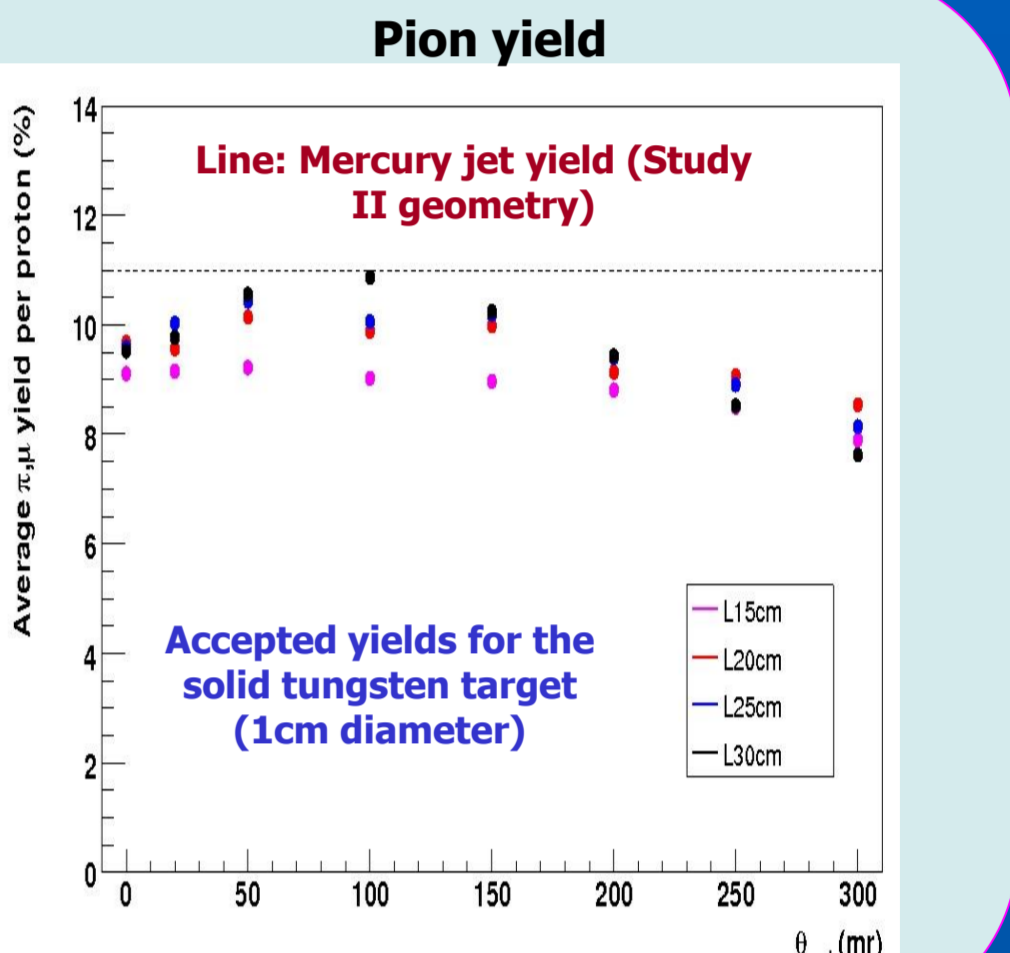

Thermal stress is a problem for solid targets so the shock studies are the main thrust of the UK activity.

Thermal Shock in Solids

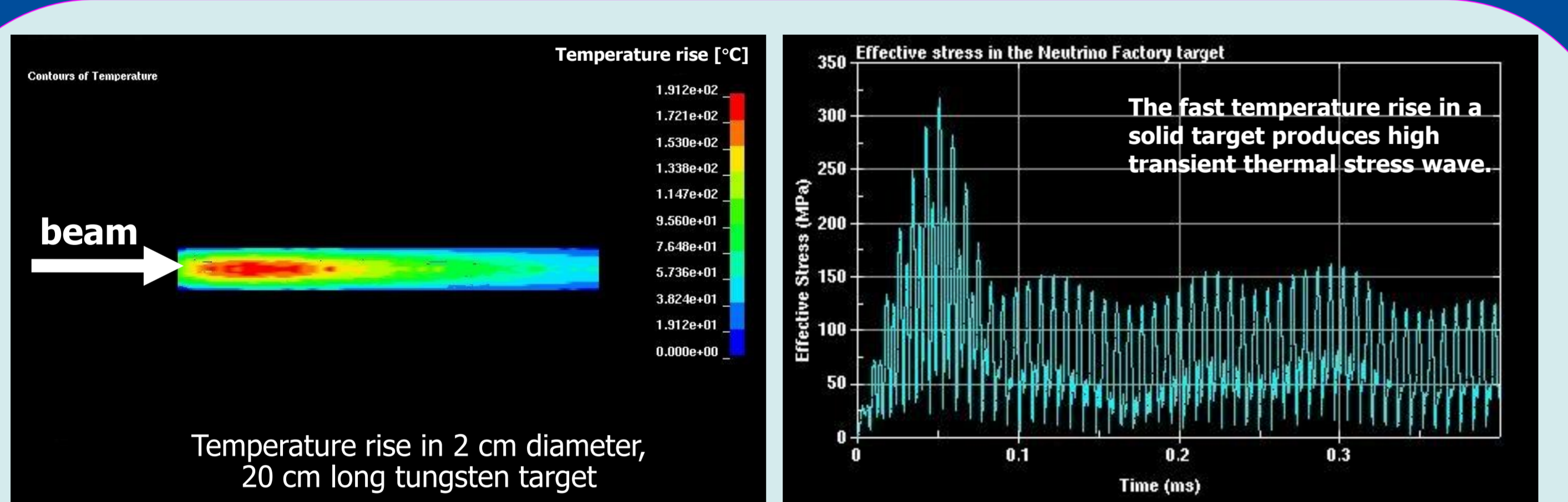

Modern computer codes such as LS-DYNA can be used to simulate the material response in such situations. For example, the induced thermal stress wave has an amplitude at the level of several hundreds of MPa resulting from the energy deposition of 10 GeV protons (4 MW beam power) in 2 cm diameter, 20 cm long tungsten target.

Ideally it would be best to do a full scale life test on a real size target in a beam over 1-10 years. However, beams of this power are not readily available for any length of time.

Fortunately, the very same level of stress can be induced in the material by passing a fast, high current pulse through a thin wire.

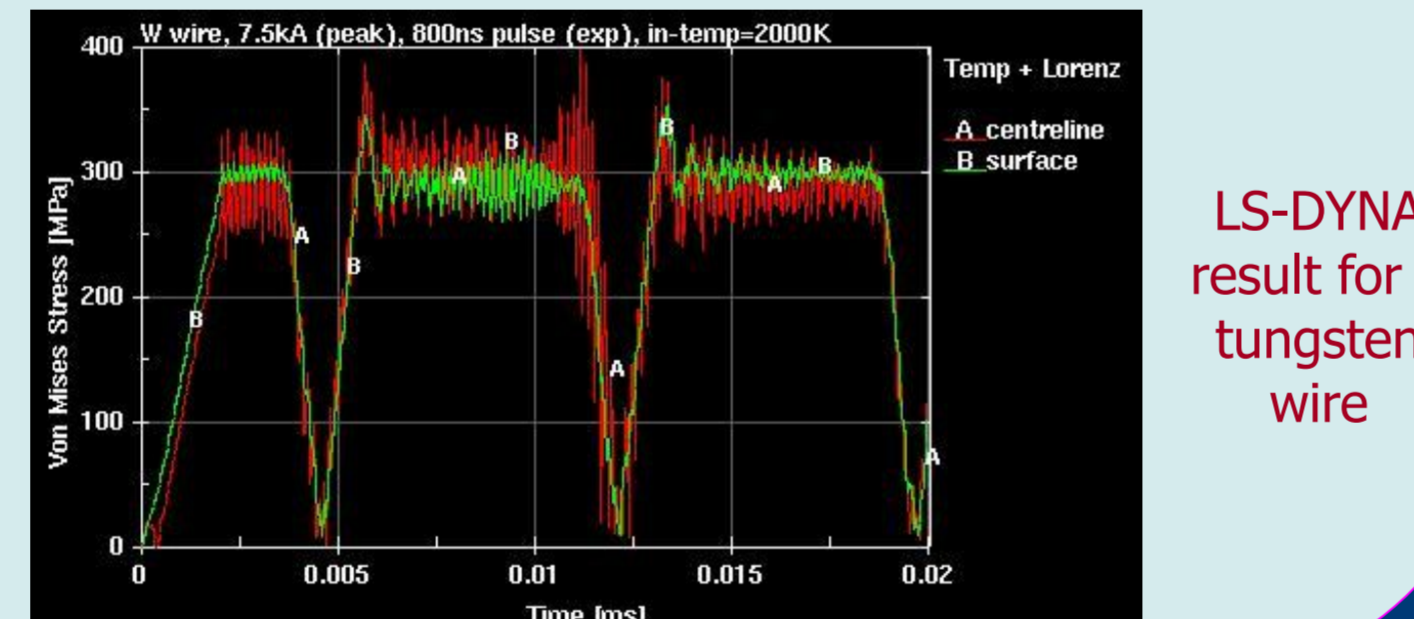

Current Pulse – Wire Tests at RAL

The pulsed heating of a small tungsten (tantalum) wire was proposed as a method for measuring the properties of the candidate materials under controlled laboratory conditions.

Schematic circuit diagram of the wire test equipment

Test wire, 0.5 mm Φ

Coaxial wires

Pulsed Power Supply:
 0-60 kV; 0-10000 A
 100 ns rise and fall time
 800 ns flat top
 Repetition rate 50 Hz or sub-multiples of 2

Vacuum chamber, 2×10^{-7} - 1×10^{-8} mbar

Test equipment at RAL

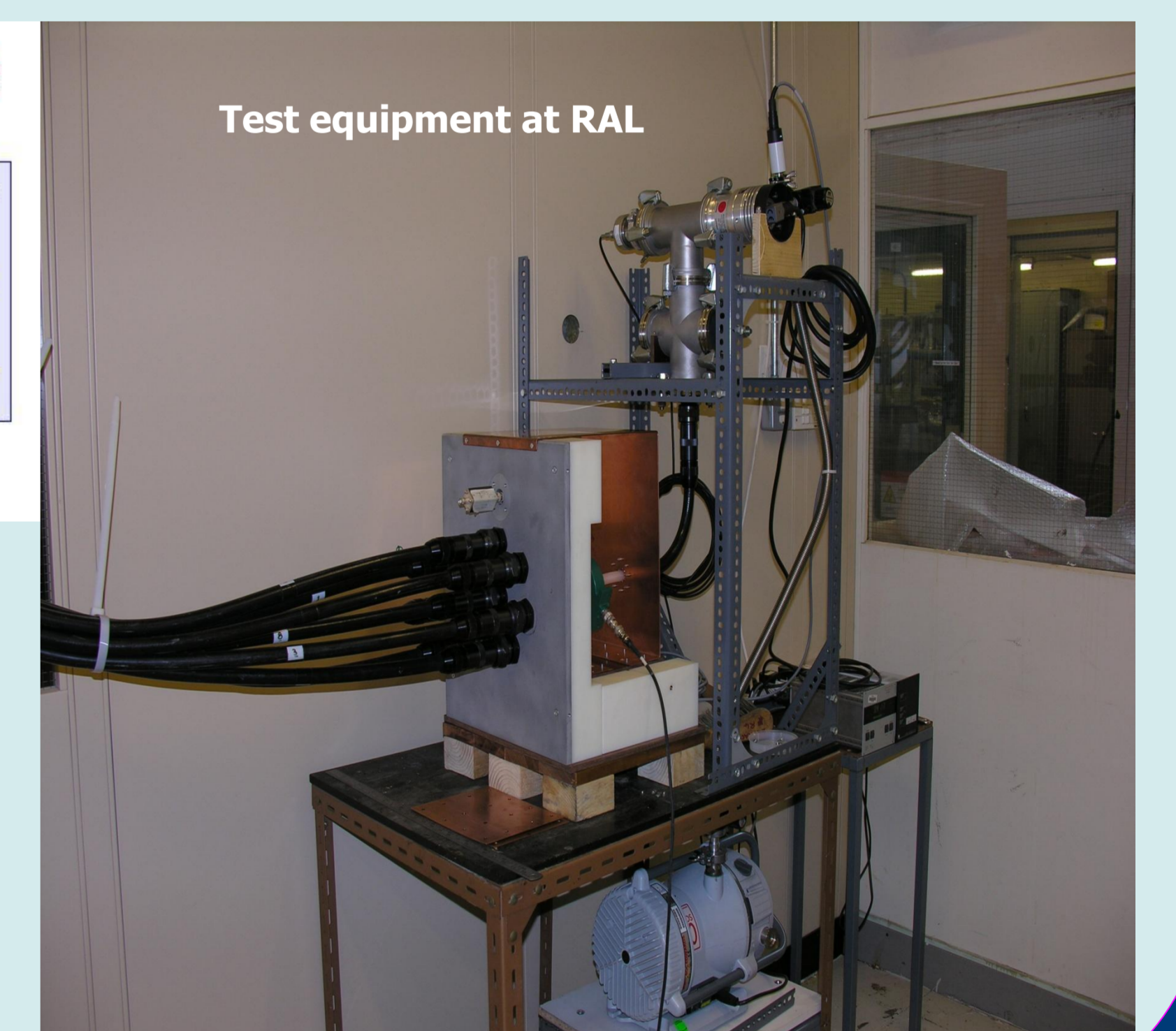

Pulsed wire

Lifetime/Fatigue Tests Results

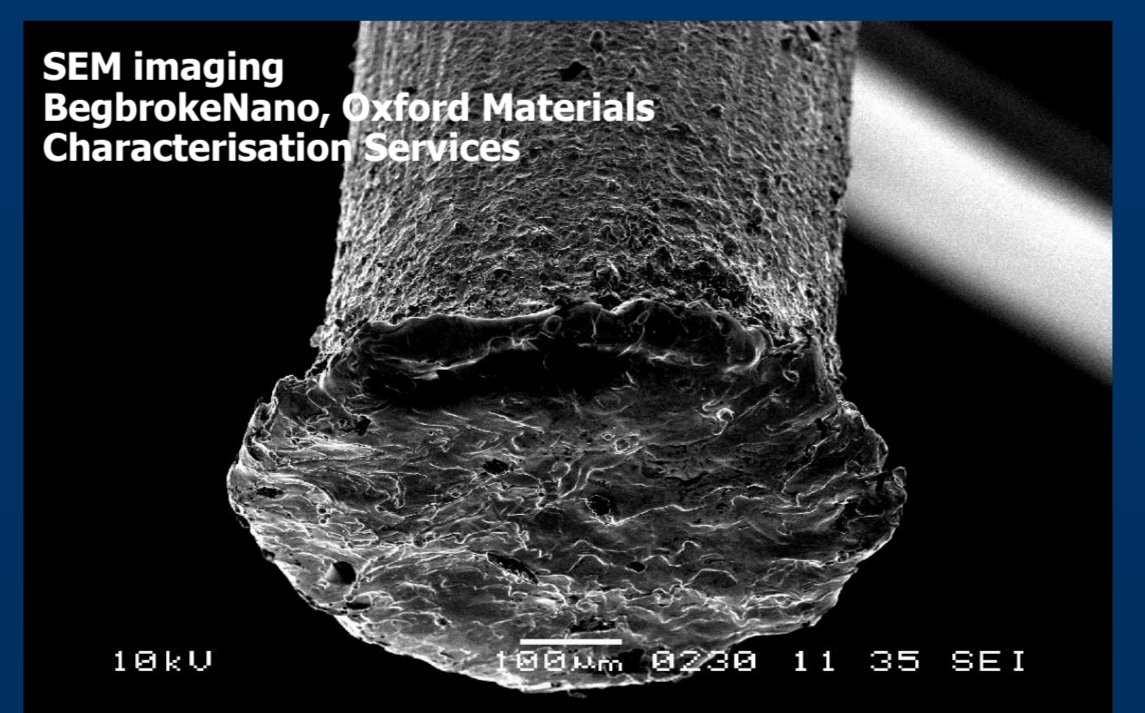
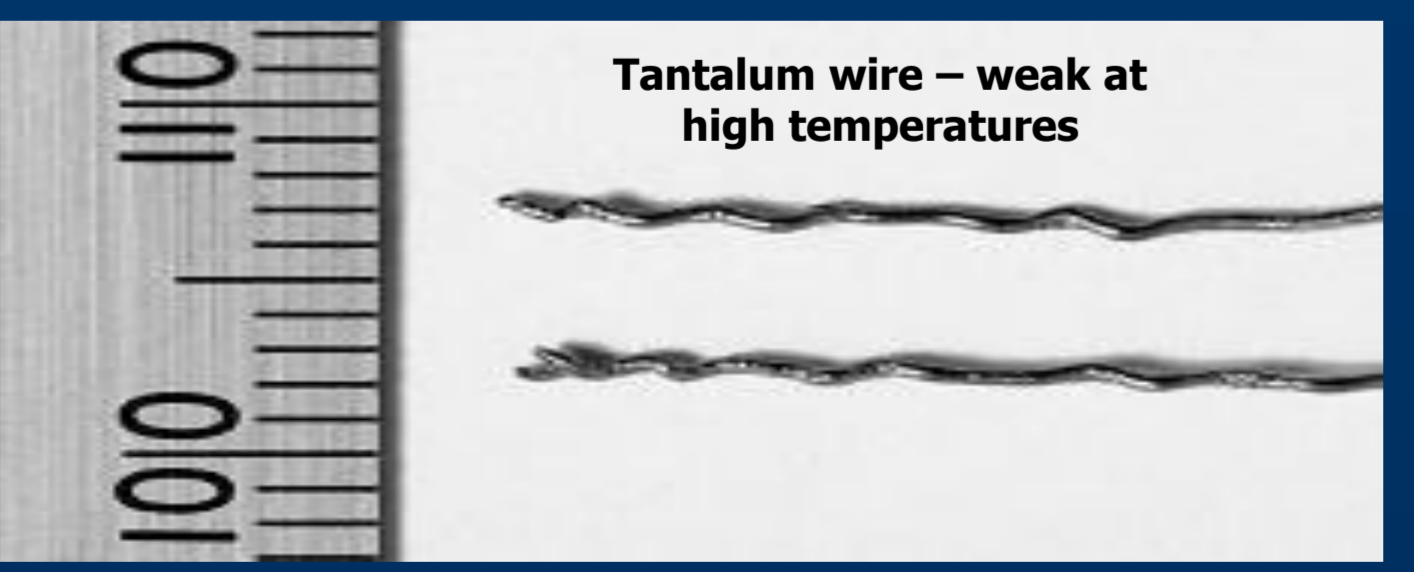

Tungsten – much better!

Material	Current (A)	ΔT (K)	Max. T (K)	Pulses to failure	Eq. power (MW)
Tantalum	3000	60	1800	0.2×10^6	(MW)
Tungsten	5560	130	1900	4.2×10^6	2.7/5.0
	5840	140	2050	$>9.0 \times 10^6$	3.0/5.4
Connector failed	7000	190	2000	1.3×10^6	4.3/7.8
	6200	160	2000	10.1×10^6	3.3/6.1
Cable #6 failed	8000	255	1830	2.7×10^6	6.1/13
	7440	230	1830	0.5×10^6	5.2/11.4
	6520	180	1940	26.4×10^6	4.1/8.7
	4720	77	1840	$>54.4 \times 10^6$	2.1/4.5
	6480		~600	$>80.8 \times 10^6$	4.0/8.6

Equivalent power at Neutrino Factory (2cm/3cm diameter target)

More than 26 Million pulses at 4 MW

Better at lower temperature!

More than sufficient lifetime demonstrated:
 > 10 years for 2cm diameter target (> 20 years for 3cm diameter target)

LDV Tests

Measurements of the velocity and displacement of the surface of the wire using Laser Doppler Vibrometer will allow us to understand the behavior of the different candidate materials under shock conditions similar to that expected at the Neutrino Factory.

Thermal expansion of the wire as a function of applied current

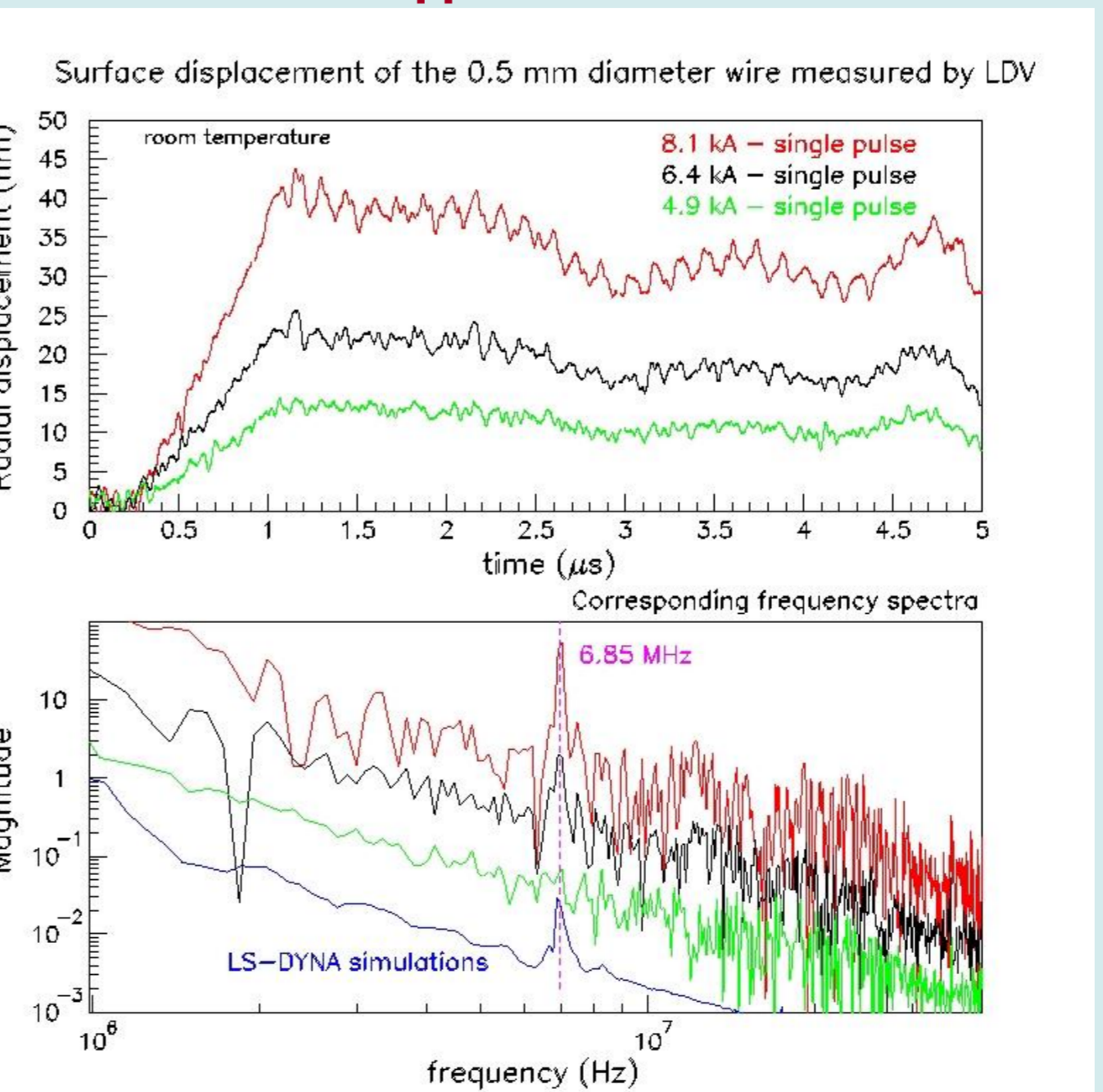

LDV: Laser Doppler Vibrometer



Characteristic frequency of the wire vibration can be used to directly measure Young's modulus of tungsten as a function of temperature and to confirm modelling results.

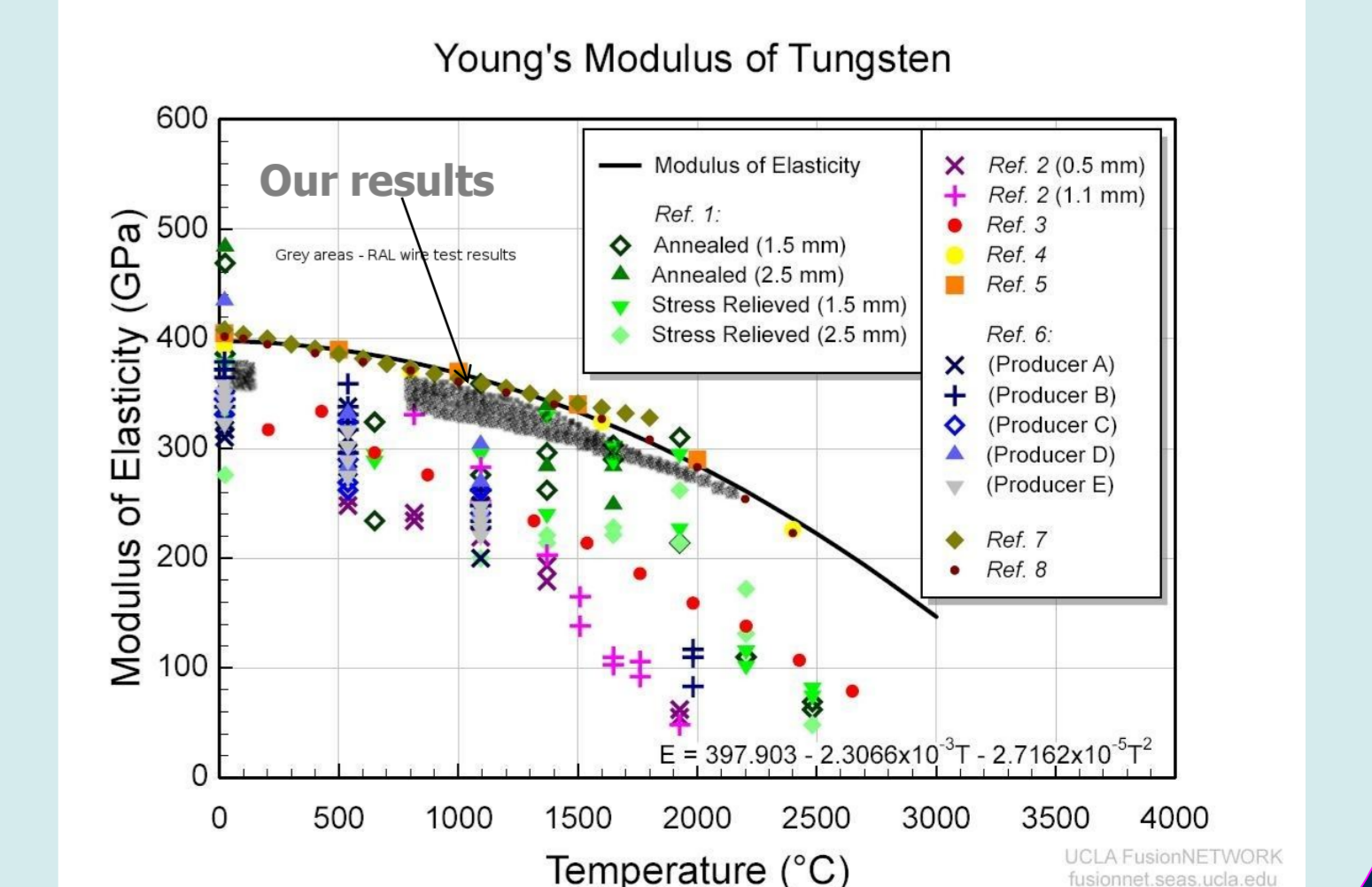

Young's modulus of tungsten remains high at high temperature and high stress!