

Tungsten Behaviour at High Temperature and High Stress

Goran Skoro¹, Rob Edgecock², Roger Bennett², Steven Gray², Adrian McFarland², John Back³, Chris Booth¹

¹University of Sheffield, ²Rutherford Appleton Laboratory, ³University of Warwick United Kingdom

Tungsten Target for a Neutrino Factory

At the Neutrino Factory the target operates at very high mean power dissipation and extremely high energy density. This high power density creates severe problems in dissipating the heat and the short pulses produce thermal shocks due to the rapid expansion of the target material. These shocks can potentially exceed the mechanical strength of solid materials.

Several targets which potentially can withstand the huge power density are currently being considered worldwide:

- Mercury (or a liquid metal) jets
- Contained flowing mercury (or a liquid metal)
- Solid target – tungsten bars**
- Granular solid target

UK activity

The pulsed heating of a small tungsten wire was proposed as a method for testing the lifetime of the tungsten under extreme conditions.

Schematic circuit diagram of the wire test equipment

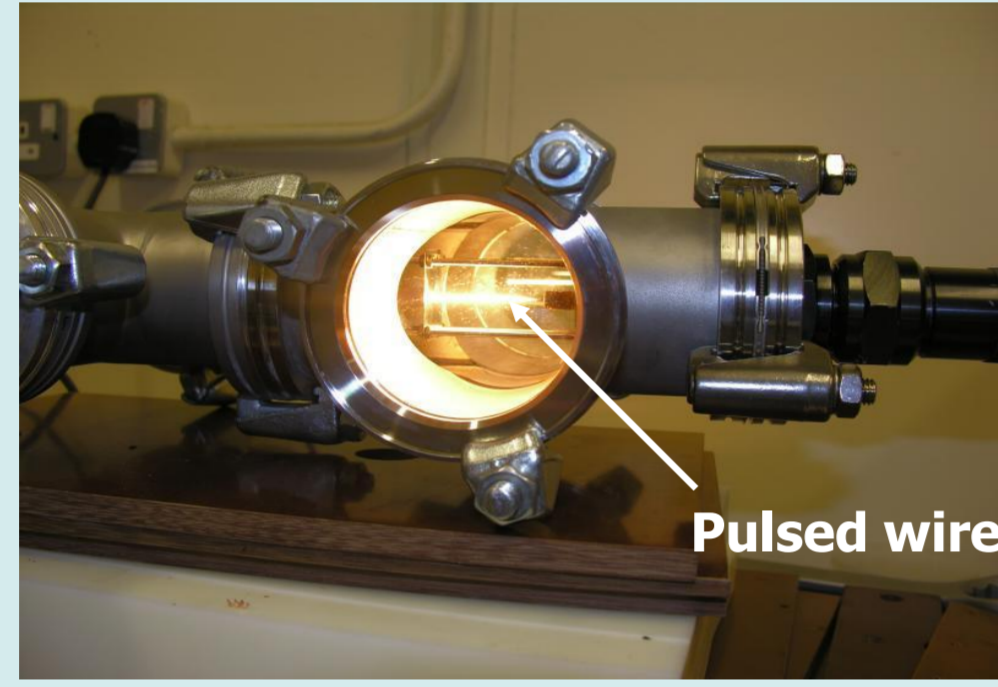
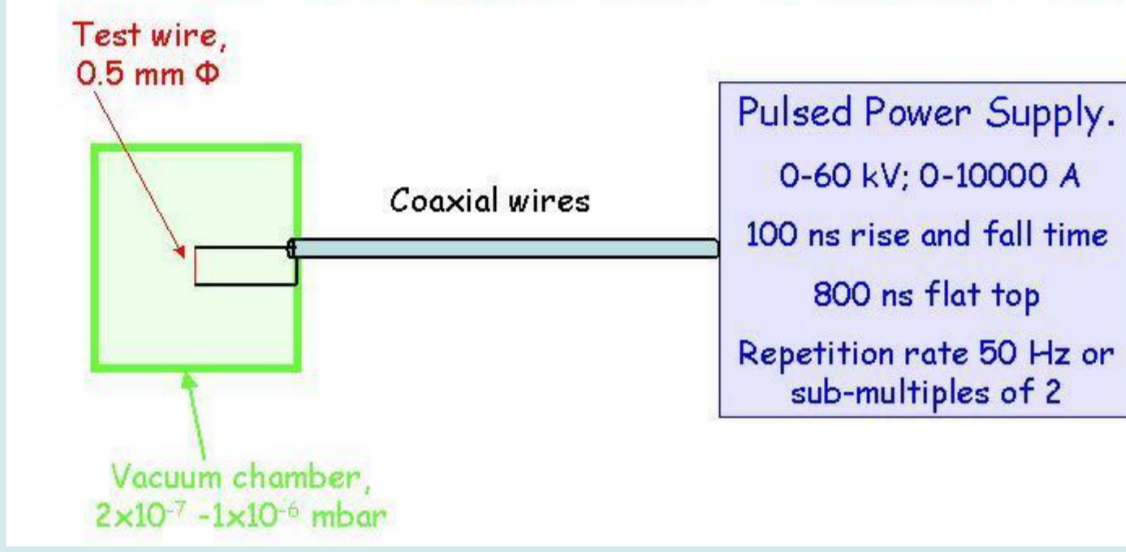

More than sufficient lifetime demonstrated:

- > 10 years for 2 cm diameter target
- > 20 years for 3 cm diameter target

This conclusion is (partly) based on simulation results.

Can we measure tungsten properties directly?
Can we benchmark simulation results?

LDV: Laser Doppler Vibrometer

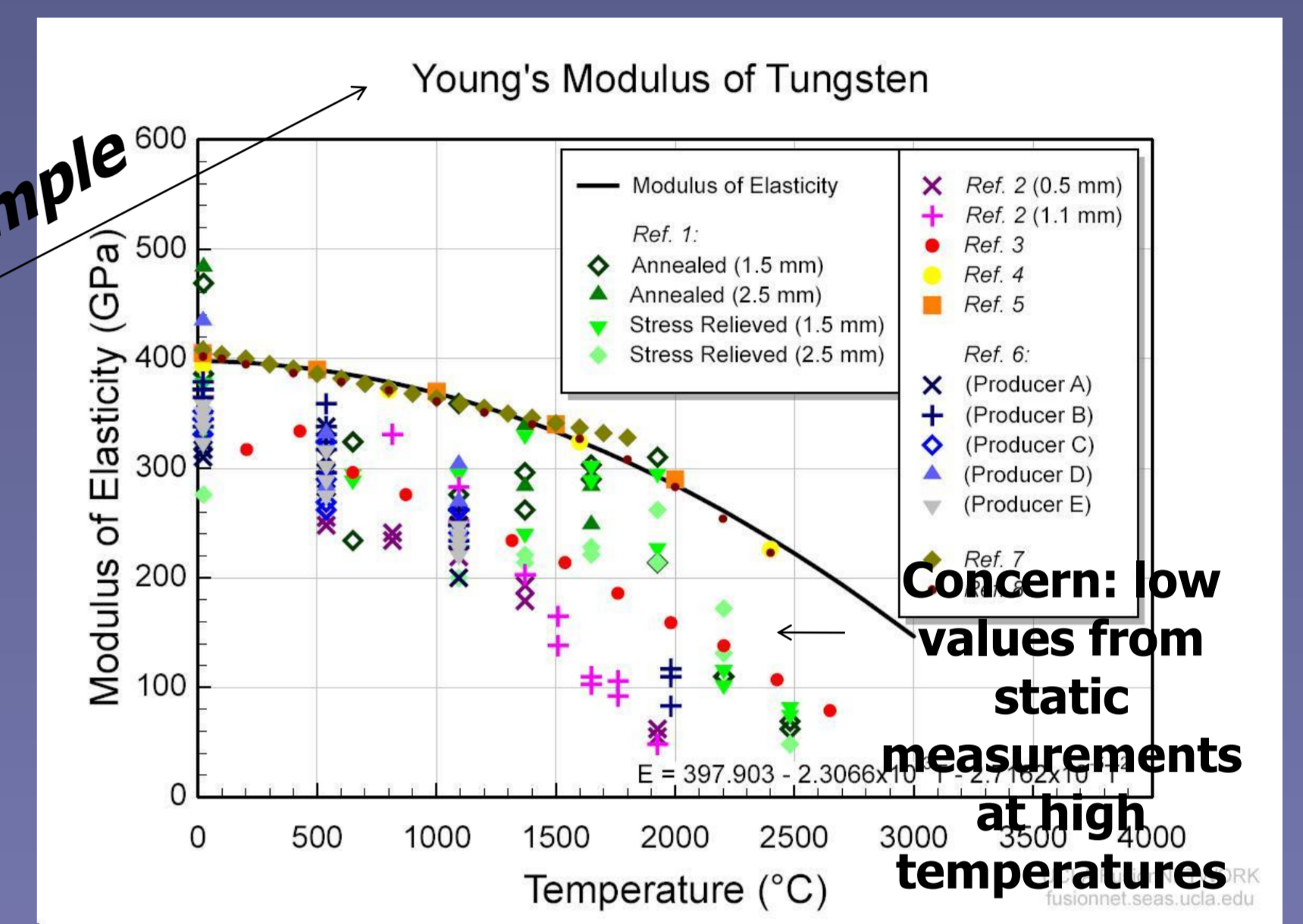
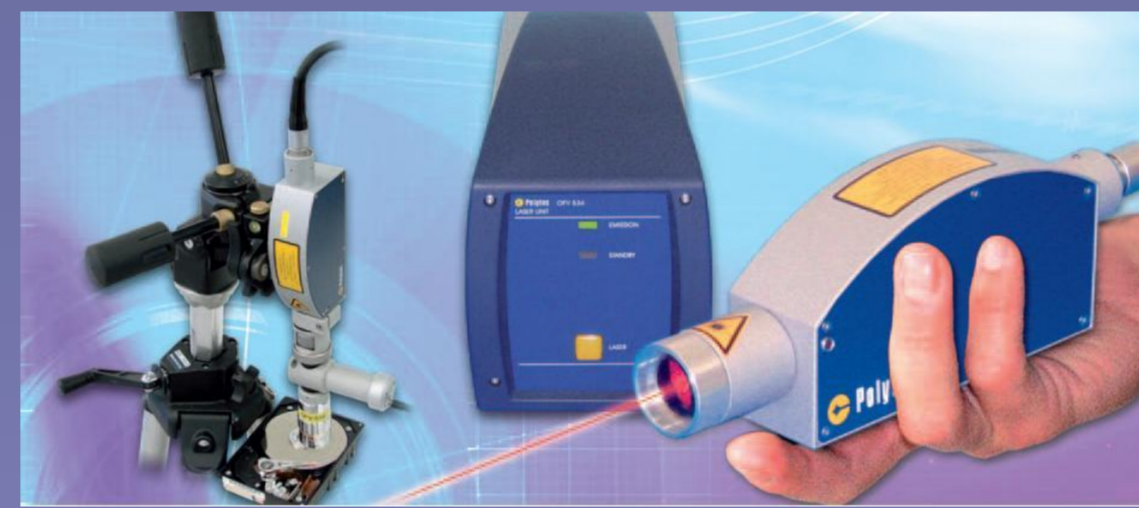

Laser Doppler Vibrometer (LDV) for measuring the displacement and velocity of the surface of the wire during pulsing.

Experiment

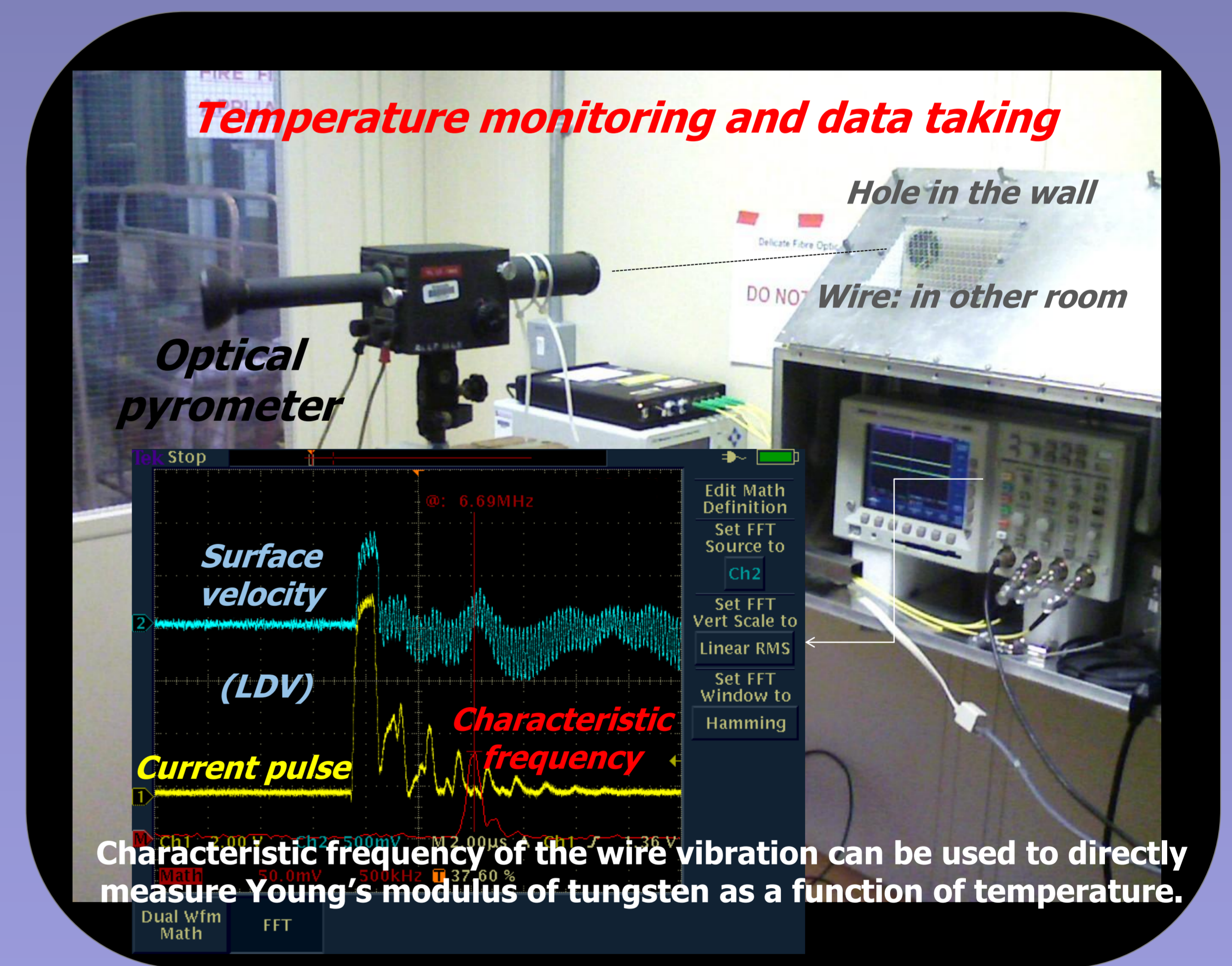
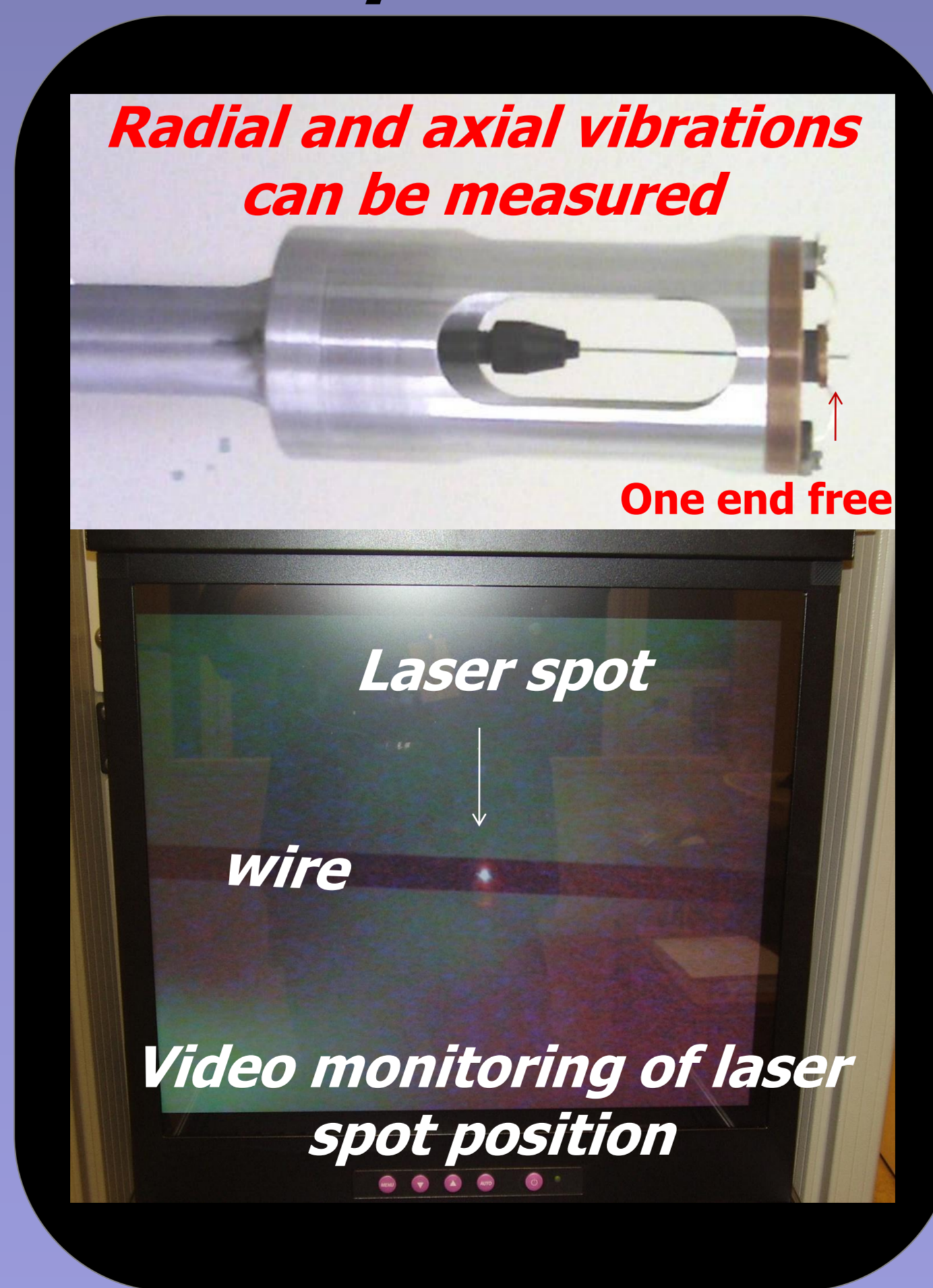
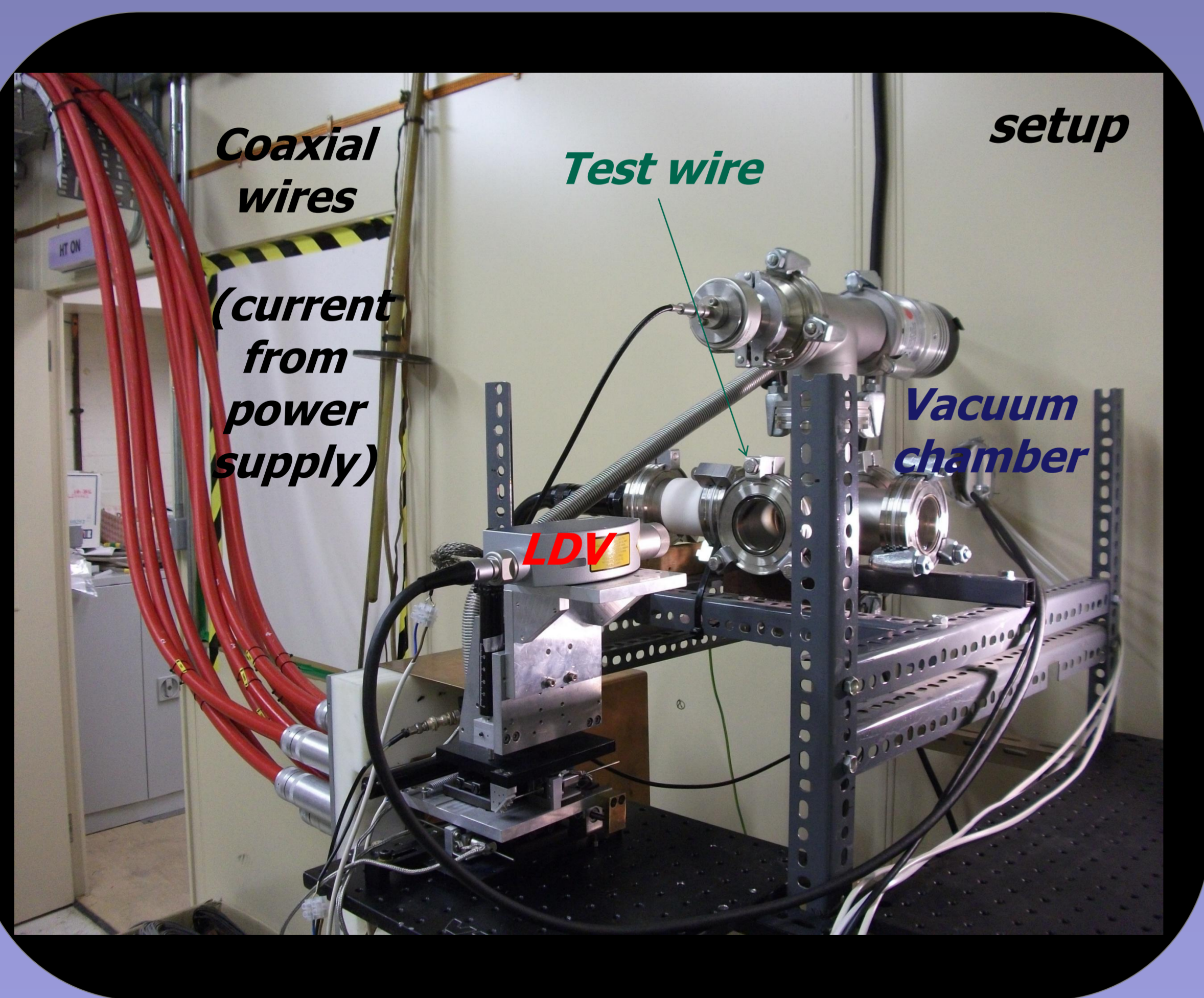

Results

Thermal expansion of the wire as a function of applied current

Radial velocity of the wire as a function of temperature

Radial velocity of the tungsten wire under extreme conditions

Characteristic frequency of radial oscillations

Young's modulus of tungsten

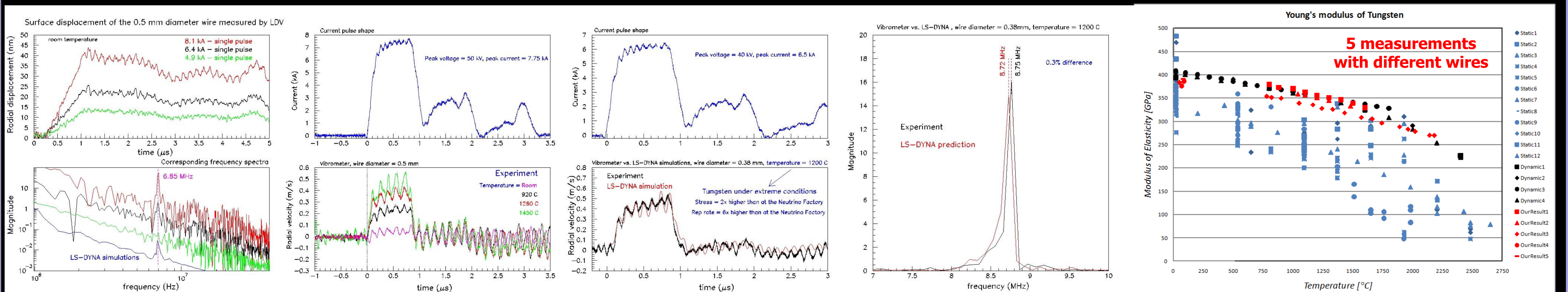

Nice agreement between experiment and simulations!

Young's modulus of tungsten remains high at high temperature and high stress!