

# OPTIMISING PION PRODUCTION TARGET SHAPES FOR THE NEUTRINO FACTORY

S.J. Brooks\*, RAL, Chilton, OX11 0QX, UK

## Abstract

The neutrino factory requires a source of pions within a momentum window determined by the ‘muon front end’ accelerator structure downstream [1]. The technique of finding which parts of a large target block are net absorbers or emitters of particles may be adapted with this momentum window in mind. Therefore, analysis of a hadronic production simulation run using MARS15 [2] can provide a candidate target shape in a single pass. However, changing the shape of the material also affects the absorption/emission balance, so this paper investigates iterative schemes to find a self-consistent optimal, or near-optimal, target geometry.

## PRINCIPLE

The problem of finding the optimal shape for any particle target can be stated as seeking the density distribution  $\rho(\mathbf{x})$  that maximises the total yield  $Y$  of particles that are useful for the application considered. Note firstly that the yield is actually a functional  $Y[\rho]$  because it depends on the entire density distribution and secondly that the space of possible shapes is too large to scan exhaustively. It is possible, however, to linearise  $Y$  and get the following approximation

$$Y[\rho] \simeq \int y(\mathbf{x}) \frac{\rho(\mathbf{x})}{\rho_{\text{Ta}}} dV,$$

where  $y(\mathbf{x})$  is a volumetric yield in the regions filled with material (Tantalum in this study). Linearising  $Y$  is equivalent to stating each region of space has the same potential production of useful particles regardless of the configuration of material elsewhere, which is an idealisation. It becomes most accurate in situations where showering particles are only travelling ‘outwards’ in a target with no internal holes, so that local yield is not affected by back-scatter from interactions further out or lack of material further in.

Modern particle–matter interaction codes have the ability to determine a form for  $y(\mathbf{x})$  that is consistent with the particular shape simulated. A histogram can be constructed of useful particles produced in each unit of volume minus the number of such particles absorbed. When this is integrated over the volume of the target, the result will be the total yield  $Y$ . Given an estimate of  $y$ , the density  $\bar{\rho}(\mathbf{x})$  that maximises the linear approximation to the total yield is

$$\bar{\rho}[y](\mathbf{x}) = \begin{cases} \rho_{\text{Ta}} & \text{where } y(\mathbf{x}) > 0 \\ 0 & \text{where } y(\mathbf{x}) < 0 \end{cases},$$

assuming the density can not be greater than that of the bulk material. When repeated, this linearisation and seeking of

an approximate optimum is very like a root-finding iteration method over the space of possible functions  $\rho$ . Testing how it works in practice is the motivation for this paper.

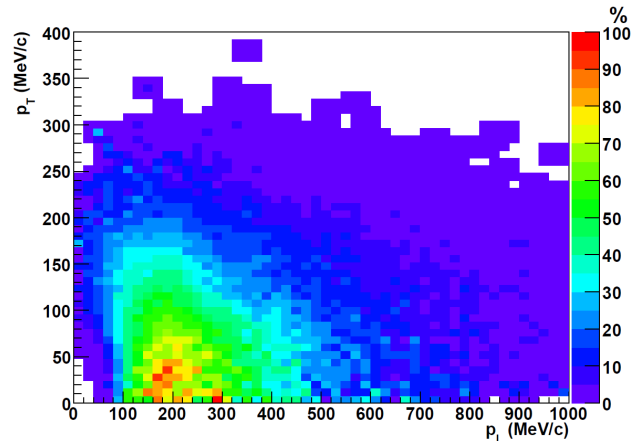

Figure 1: Probability of a pion yielding a useful muon as a function of the initial  $(p_L, p_T)$ , reproduced from [3].

In the neutrino factory, the utility of particles ( $\pi^+$ ,  $\pi^-$ ) produced by the target depends on their chances of decaying to a muon that is transmitted by the subsequent muon accelerator. This study uses the results of [3], in which the probability of a pion producing a useful muon is determined as a function of the pion’s original longitudinal and transverse momenta using particle tracking. This distribution of probabilities is shown in figure 1. Henceforth the term *useful pions* is used to mean yield of pions weighted by these probabilities depending on their momentum.

Table 1: Parameters of the pion production simulation and geometry iteration.

Parameter	Value
Proton energy	10 GeV
Beam distribution	Parallel, circular parabolic
Beam radius	1 cm ( $r_{\text{max}}$ )
Target material	Tantalum
Magnetic field	20 T in $z$ direction
Geometry volume	1 m $\times$ 10 cm radius cylinder
Geometry resolution	2 mm in $z$ and $r$
Code used	MARS15.07 [2]
Hardware	100 CPU cores on SCARF [4]
Protons simulated	$10^6$ ( $10^4$ per core)

\* stephen.brooks@stfc.ac.uk

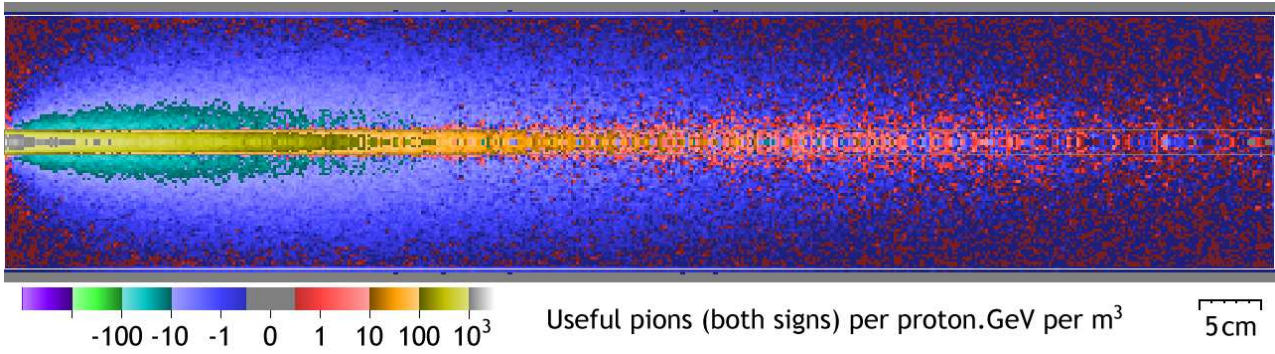

Figure 2: Net production balance of useful pions in the completely solid block geometry.

## SIMULATION SETUP

Simulations were run using the parameters in table 1. The 10 GeV proton energy and 20 T magnetic field come from the findings of [1]. The problem is cylindrically symmetric, so the volume was binned in  $(z, r)$  coordinates. For geometries where some of these bins are to be filled with Tantalum and some not, the extended geometry mode of the MARS15 [2] code allowed a suitable volume of revolution to be constructed from ‘cylinders’ (actually annuli) with an inner as well as an outer radius. The file GEOM.INP was produced automatically by a postprocessing program.

The histogram of useful pion balance (production minus absorption) was produced by customising the MARS user routine MFILL to accumulate the contributions of each pion track segment to an array: positively at the segment start and negatively at the segment end. Noise in the histogram was found to be reduced if the contributions were bilinearly weighted into  $2 \times 2$  adjacent cells of the array.

## RESULTS

The iteration started with a completely solid block of tantalum, whose useful pion balance (the function  $y(\mathbf{x})$ ) is plotted in figure 2. Yields are positive in the region of the proton beam, negative outside where the pions are only absorbed by the tantalum and lacking in statistics at the far end where few particles penetrate.

The first attempt at iteration was to repeatedly remove areas of tantalum where the useful pion balance was negative. The resulting shapes are shown in figure 3, where geometry 0 is the solid block and 1 is the positive balance regions taken from figure 2. A piece of tantalum is left over that resembles a tapered cylindrical target with  $r_{[\text{cm}]} = \sqrt[4]{\min\{1, 1.5 - 0.07z_{[\text{cm}]}\}}$  and material obstructing the spiralling paths of useful pions is mostly removed.

This technique can only remove material but is it conceivable that a radical change in geometry such as that between shapes 0 and 1 may also change  $y(\mathbf{x})$  so that it becomes positive outside the material-filled region. To allow material to fill these new positive pion balance regions, the method shown in figure 4 was used to ‘expand’ geometries such as 1 into adjacent bins, to make geometries like 1x.

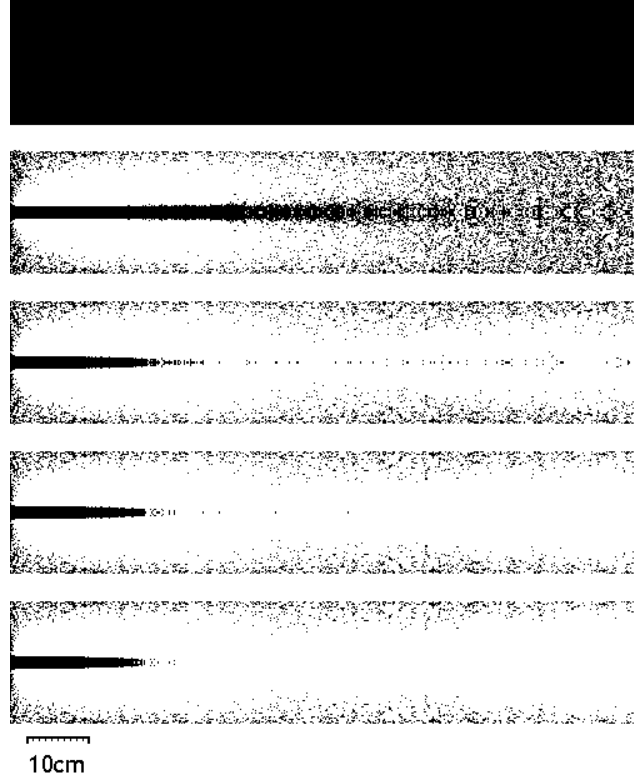

Figure 3: Evolution of target geometries 0, 1, 2, 3, 4 (top to bottom) in which material is only removed.

These expanded geometries are themselves sub-optimal but can then have the negative pion balance regions removed in the next iteration, making geometries like 2e that only contain positive-yielding regions but are able to grow as well as shrink. Figure 5 shows how this new iteration algorithm relates to the first.

The new algorithm results in the geometries shown in figure 6. A slightly longer target results, with the most interesting new feature being that some of the surrounding material has become denser just downstream of the target. This can only have happened because these regions create new useful pions from high energy secondary particles that would otherwise be lost activating the surrounding magnet.

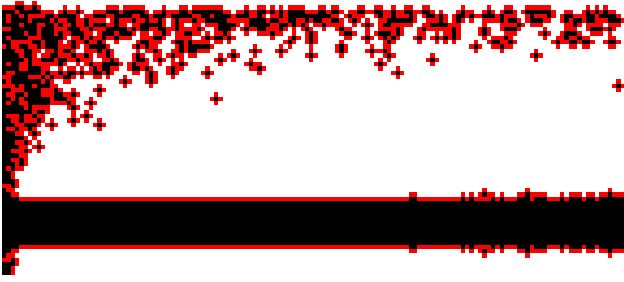

Figure 4: Detail of how geometry 1x was produced by expanding geometry 1, shown in black. Red bins are the newly added material.

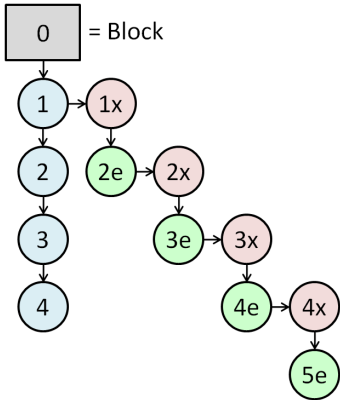

Figure 5: Relation of iteration geometries to the original block. Downward steps remove regions that are net absorbers of pions; rightward steps expand the geometry.

Flexible though the second algorithm is, it did not perform as well as the original removal-only algorithm, as can be seen from the yields in figure 7. This could be because it is too aggressive in adding new material so that the equilibrium shape is too large: a single filled bin can produce five bins of material in the next iteration, which are difficult to completely remove in an marginal area with poor statistics.

## CONCLUSION & FUTURE WORK

This paper has presented a method of target design in which the target shape is dictated by (simulated) physics processes rather than other assumptions. This was applied to the solid neutrino factory target problem and the geometry 4 produced a total useful pion yield  $7.6 \pm 0.6\%$  higher than a  $20 \times 1$  cm cylindrical target. An alternate method produced the geometry 5e with a  $3.1 \pm 0.6\%$  higher yield than the cylinder.

The effects of changing the incoming proton beam energy or radius were not considered in this paper, although this could be done in future if the relevant engineering constraints are taken into account. The second iterative method could be improved to not over-produce material in statistics-limited areas.

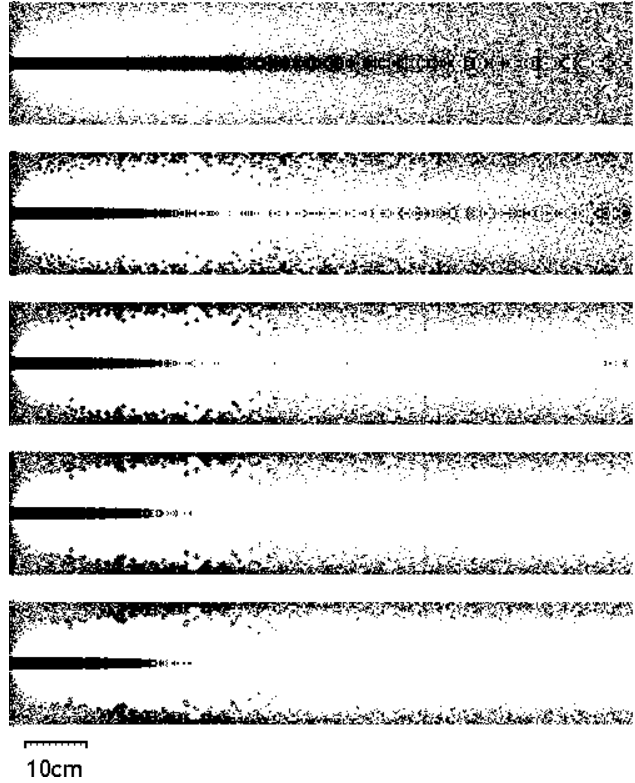

Figure 6: Evolution of target geometries 1, 2e, 3e, 4e, 5e (top to bottom), where the target is 'expanded' before each material removal step.

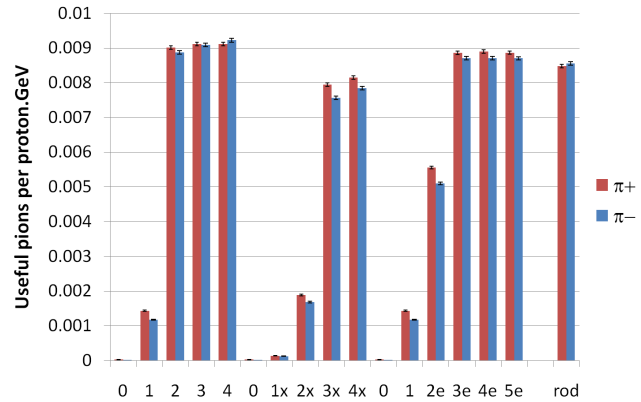

Figure 7: Useful pion yields from geometries under iteration. 'Rod' is a  $20 \times 1$  cm radius cylinder for comparison.

## REFERENCES

- [1] *The International Scoping Study of a Neutrino Factory and Superbeam Facility*, ISS Collaboration, RAL-TR-2007-023.
- [2] *The MARS Code System* version 15.07, by N.V. Mokhov, available from <http://www-ap.fnal.gov/MARS/>.
- [3] *Pion and Muon Yields from a 10 GeV Proton Beam on Various Targets*, J. Back, PoS **084**, NuFact '08, Spain, June 2008.
- [4] The SCARF-IBIS queue of the SCARF supercomputing cluster at RAL <http://sct.esc.rl.ac.uk/SCARF/hardware.html>.