



Issues Dealing With Safe Handling of Mercury

Philip T. Spampinato
(spampinatop@ornl.gov, 865-576-5267)

Van B. Graves
Tony A. Gabriel

MERIT Review Meeting

December 12, 2005

Brookhaven National Laboratory
Upton, NY

Outline



- **Properties, Safety Limits**
- **Background - SNS Target Test Facility**
- **Installing Hg & New Equipment into TTF**
- **Hg Vapors & Air Filtration**
- **Filling the Target Loop**
- **What if ...?**
- **Conclusions**

Properties and Safety Limits



- **Atomic Weight: 200.59**
- **Boiling Point: 357° C**
- **Specific Gravity: 13.6**
- **Vapor Pressure: 0.0012 mm Hg**
- **Vapor Density: 7.0 (air = 1.0 @ 20° C)**
- **Vapor: colorless, odorless**
- **Solubility: insoluble in water**
- **NIOSH/OSHA: 0.05 mg/m³, 10 h/day; 40 h/wk**
- **TTF: action level is set to 0.0125 mg/m³**
 - **Use respirator with Hg cartridge**

Mercury Health Effects



<i>Exposure Route</i>	<i>Acute Effects</i>	<i>Chronic Effects</i>
Ingestion	Acute poisoning following ingestion causes metallic taste, thirst, abdominal pain, vomiting, and diarrhea. May damage kidneys and central nervous system. Death may occur from uremia.	Chronic ingestion causes skin disorders, salivation, diarrhea, anemia, leukopenia, liver and kidney damage.
Skin Contact	May be absorbed through the skin causing effects similar to those of acute inhalation.	May be absorbed through the skin causing effects similar to those of chronic inhalation.
Eye Contact	May cause irritation.	None known.
Inhalation	Inhalation of vapor results in dyspnea, cough, fever, nausea, vomiting, diarrhea, stomatitis, salivation, and metallic taste. Pulmonary disturbances may follow. Anuria may occur. May damage the lungs, liver, kidneys, central nervous system and reproductive system.	Chronic inhalation may result in tremors, salivation, stomatitis, loosening of the teeth, blue gum line, peripheral neuropathy, nephritis, diarrhea, anxiety, headache, weight loss, anorexia, and psychic disturbances.
Most Likely Routes of Entry	Ingestion, skin absorption, inhalation of vapors	

Mercury First Aid Instruction



<i>Exposure Route</i>	<i>Treatment</i>
Ingestion	Induce vomiting. Get medical attention immediately.
Skin Contact	Remove contaminated clothing and shoes immediately. Wash affected area with soap or mild detergent and large amounts of water until no evidence of chemical remains (approx. 15-20 minutes). Get medical attention immediately.
Eye Contact	Wash eyes immediately with large amounts of water or normal saline, occasionally lifting upper and lower lids, until no evidence of chemical remains (approx. 15-20 minutes). Get medical attention immediately.
Inhalation	Remove from exposure area to fresh air immediately. If breathing has stopped, give artificial respiration if qualified personnel are available. Maintain airway and blood pressure and administer oxygen if qualified personnel are available. Keep affected person warm and at rest. Get medical attention immediately.

Mercury Vapors

Video clip of Hg vapors at RT

<http://www.deq.state.mi.us/documents/deq-ead-p2-mercury-bb-Vapors.wmv>

- **Vapors can only be “seen” with a vapor monitor!**

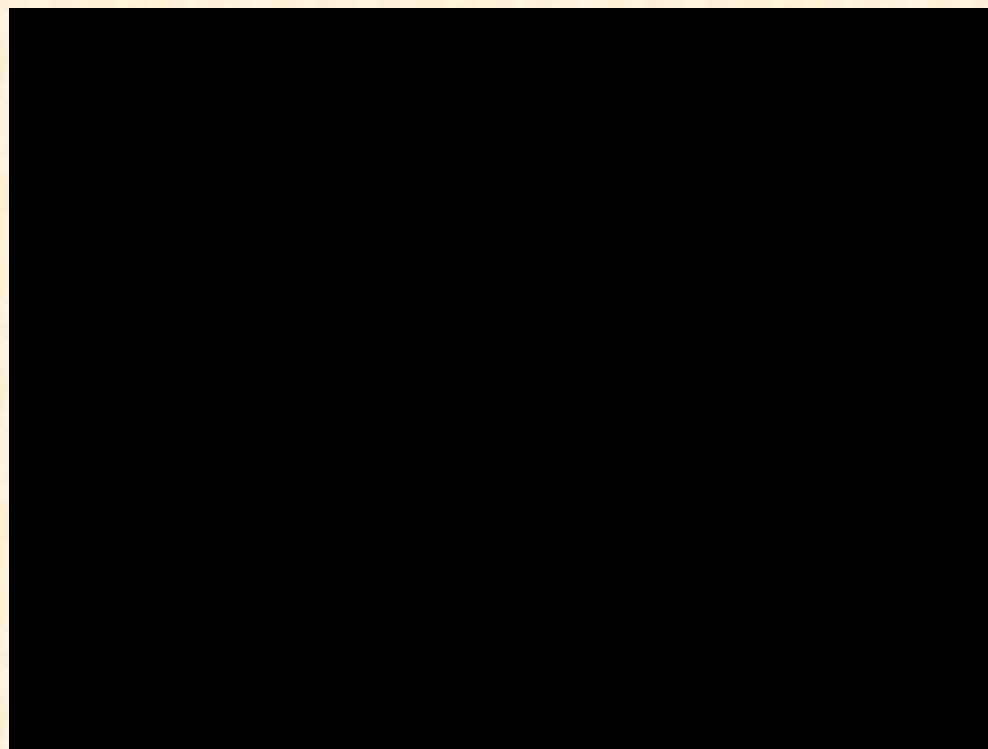

The Target Test Facility (TTF) - Background Information



- Full scale, prototype of the SNS Hg flow loop
- 1400 liters of Hg
- Used to determine flow characteristics
- Develop hands on operating experience
- Assess key remote handling design issues
- MERIT assy & testing May-Aug '06

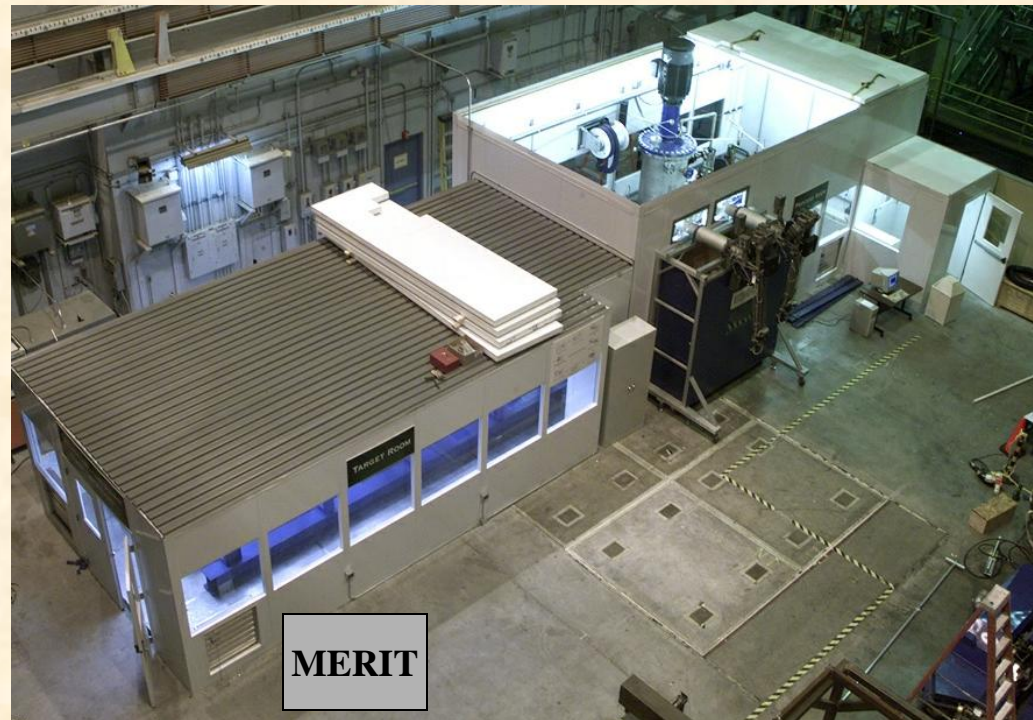

TTF Pump Room and Target Room



- **75-hp centrifugal pump**
- **Nominal flow at 1450 liters/min (380 gpm)**
- **Several equipment upgrades to the piping and target module were successfully completed**



Mercury Containers/Shipping



- Standard flask is 2 liters
- Flask + Hg weighs ~35 kg



TTF Operations – Hg Filling



- A peristaltic pump for transferring Hg was successfully tested
 - This is the preferred approach for filling the MERIT

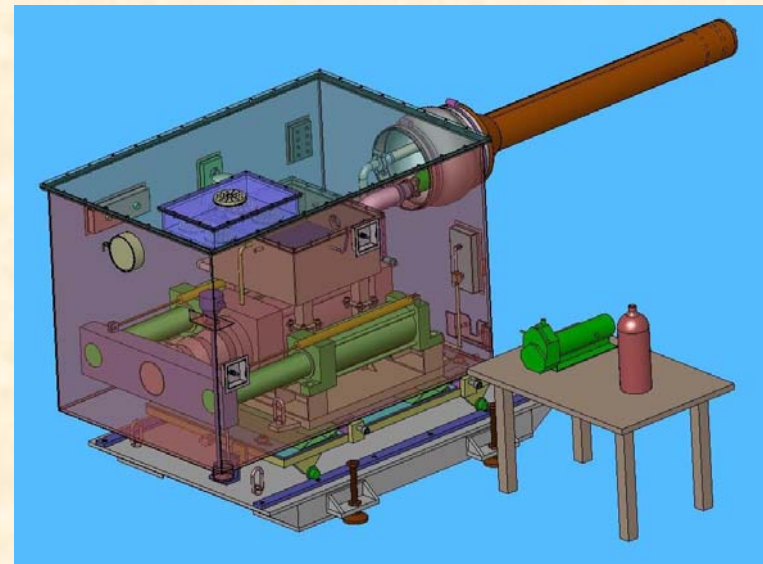

Filling (cont.)



- **TTF vacuum pump was used to transfer Hg directly into the storage tank**
 - Lower risk than using the peristaltic pump for 700 flasks
 - Faster operation, ~ 1-1/2 minutes per flask



Filling MERIT



- Secondary containment cover remains installed
- Pump directly into the sump tank
 - Air displaced from the sump tank is vented through the primary passive filter
- The portable snorkel is placed near the passive filter
- Glovebox could be used if required
 - Not considered to be necessary for MERIT

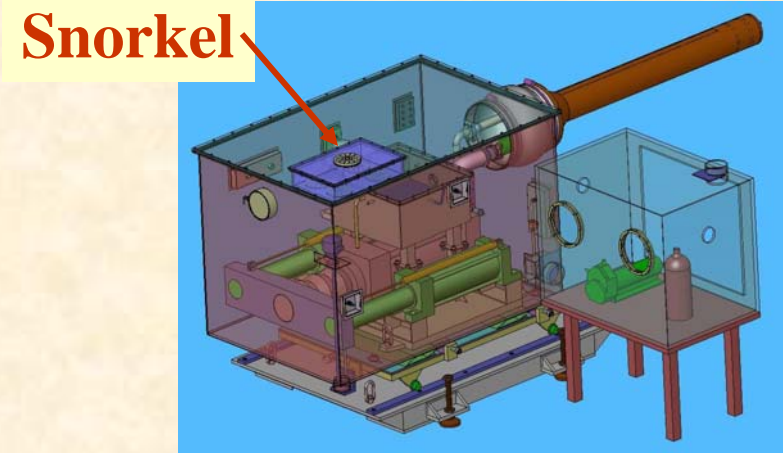
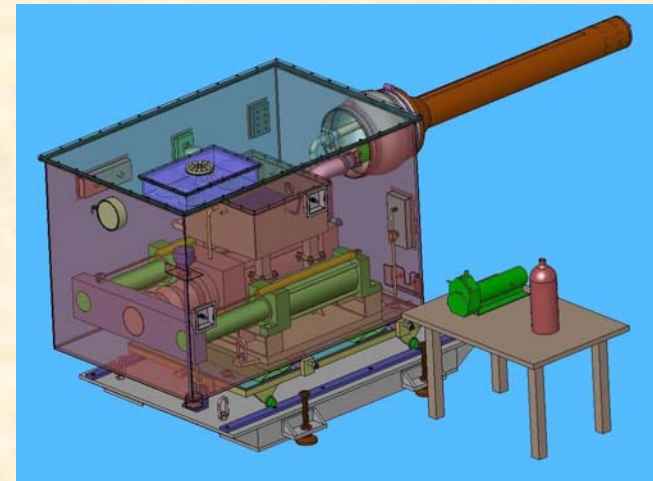

Mercury Monitoring



- **TTF Uses Jerome 431-X Vapor Analyzers**
 - **One monitor dedicated to each room and connected to the Target Test Facility PLC**
 - sample every 5 minutes
 - battery recharge every 24 hours
 - **Portable monitor used during interventions**
- **The Jerome analyzer has a range of 0.000 – 0.999 mg/m³**
 - **Sensitivity is 0.003 mg/m³**
 - **Measures the change in resistance across a gold film as a function of adsorbed Hg vapor**
- **Other monitors are available, including those that use UV absorption**



MERIT at MIT and CERN



- **Dialogue with the MIT Safety Engineering Group has begun**
 - **Presentation/discussion with CERN in August '05**
 - **Visual confirmation of off-normal events**
 - **Presentation/discussion with MIT at the October Collaboration Meeting**
 - **Safety review and target test plan to be presented to MIT in March '06**
- **In addition:**
 - **CERN will provide a second (portable) vapor monitor for sampling the tunnel environment**
 - **MIT and CERN will provide support for repackaging the target equipment and Hg for delivery back to ORNL**

Scavenger – A Portable Snorkel



- Use snorkel near open flasks in lieu of glove box
- Connect snorkel to passive filter port during filter cartridge replacement



**Sulfide-
Charcoal
Filter
(6 lbs)**



**HEPA
Filter**

Filter Replacement



- **Filter replacement requires opening the secondary containment**
 - To replace primary passive filter attach snorkel to the secondary filter port
 - Tunnel air is drawn into the secondary containment during filter replacement
 - Monitor the area adjacent to the filter

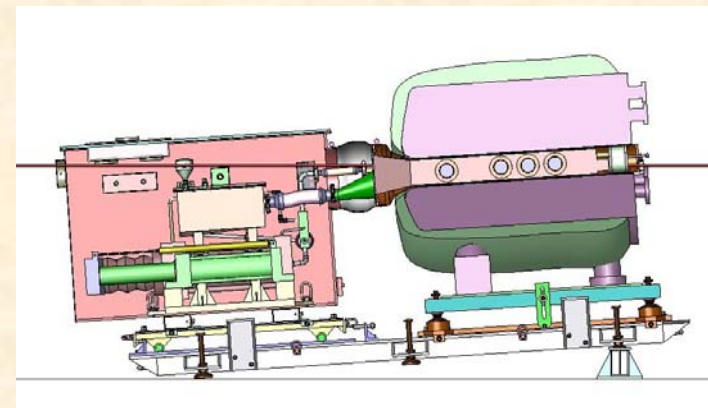
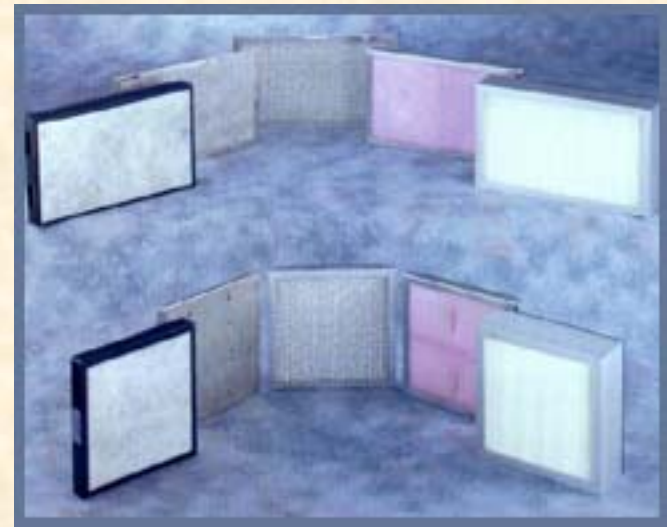

TTF Ventilation System



- **5 air changes/h**
- **Flow velocity at 25-32 ft/s (~9 m/s)**
- **Sulfide-impregnated charcoal filter (400 lbs) in-line with the building ventilation**



Filter Replac. (cont.)

Secondary Filter

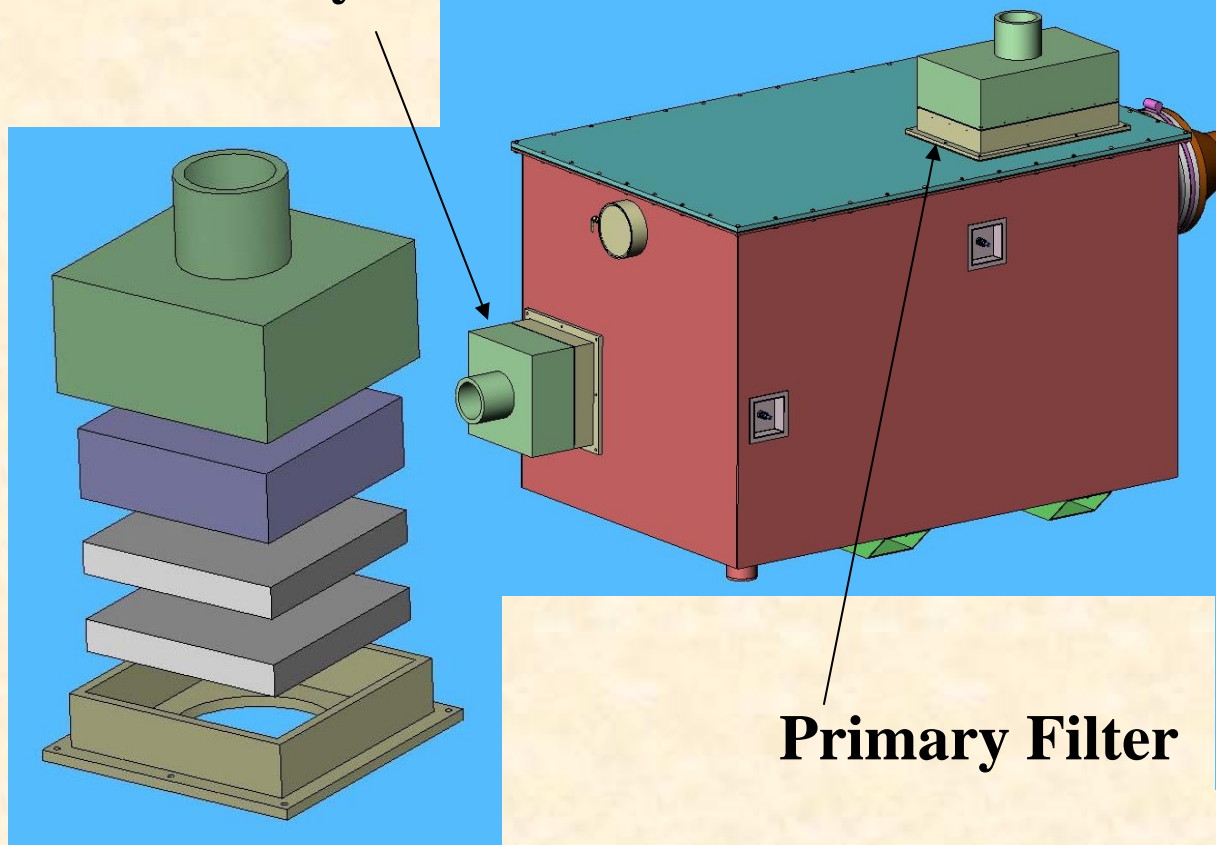

Primary Filter

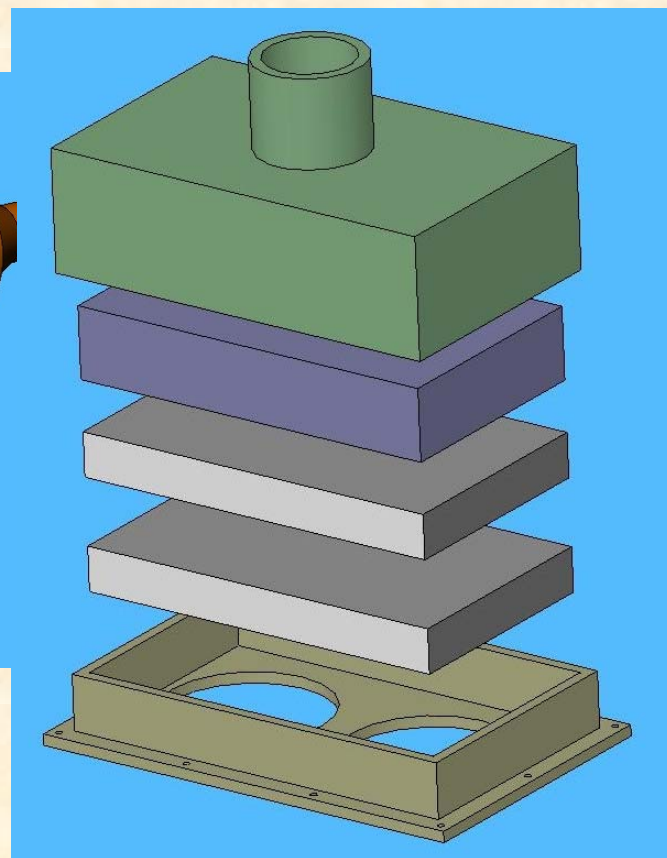

Filter Lifetime - Prelim. Calculation



Saturation Pressure

$$\log P_{sat} = -3105.5 / T_{0K} + 4.9294 \quad (\text{bar})$$

Saturation Concentration

$$C_{sat} = 2.445 P_{sat} / T_{0K} \quad (\text{Kg}_{\text{Hg}}/\text{m}^3) \quad (P_{sat} \text{ mbar})$$

Ref. Quechsilber und seine Gefahren, Swiss government worker safety report, SBA No. 145, Luzern

- Flow Rate 110 cfm
 - Temp. 25 °C
 - Filter Effic. 99.0%
 - Filter Weight 6 lbs
 - Sulfide Material 12% by weight
 - Filter Life 185 hrs
- Does not incl. reduction for humidity*



Action Scenarios (Prelim.)

- Vapors detected outside of secondary containment by monitor # 2 - assume the secondary containment is breached or that the filter is saturated
 - Confirm with readings from #1 vapor monitor
 - If confirmed ... cease operations
 - Monitor target instruments for clues to the source of leakage
 - verify by checking sump tank level sensor, conductivity sensor, and nozzle pressure sensor
 - Wait for cool down, visually inspect and sample local air
 - If levels are above action limit (0.0125 mg/m^3), inspect with full face mask-Hg respirator cartridges
 - Repair breach in enclosure if possible, pressure check, continue test operations

CERN limit ?? mg/m³

OSHA limit 0.050 mg/m³

ORNL limit 0.025 mg/m³

TTF action limit 0.0125 mg/m³

Miscellaneous Safety-Related Items



List of Miscellaneous Support Equipment for the Target System

Large Items	Small Items
Vacuum Cleaner	Merc-X Cleaning Solution
	Sponges
Portable Snorkel	Plastic Buckets
Spare Filters (qty. TBD)	Plastic Pans
	Gauze – roll
Vapor Monitor	Small Tools
Vapor Monitor Calibration Kit	Vinyl Tape
	Plastic Bags – asst'd (1 gal. – 20 gal.)
Herculite (plastic sheeting)	1-Liter Plastic Bottles
	Lab Coats
Peristaltic Pump/Tygon Tubing	Shoe Covers
	Safety Glasses
	Tyvek Hooded Suits
	Nitrile Gloves
	Full Face Mask/Respirator Cartridges

Operations Experience: Installation of He Bubbler

- Bubbler test equipment was recently added to TTF
- He leak tested all joints at 25 psig before filling with Hg

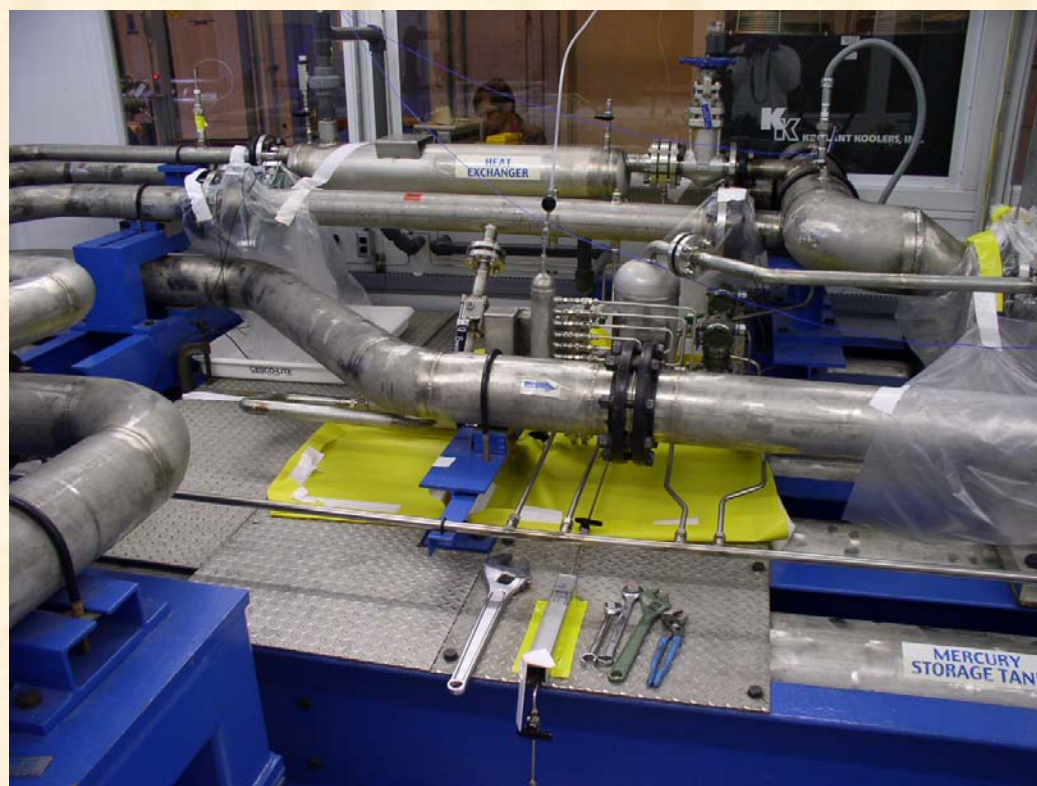
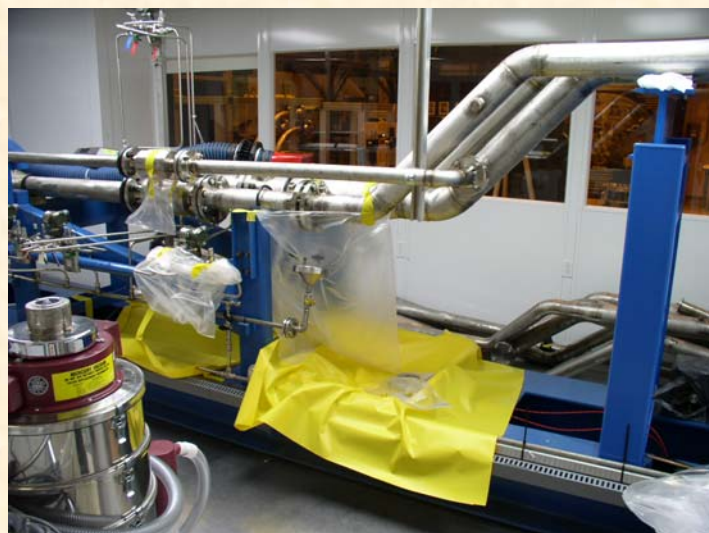

Proper Attire Is Required



- **Overalls, gloves, and overshoes are the minimum requirement**



Mercury Puddling

- **Mercury will collect into small droplets and large puddles even in pipes sloped at 1 degree**

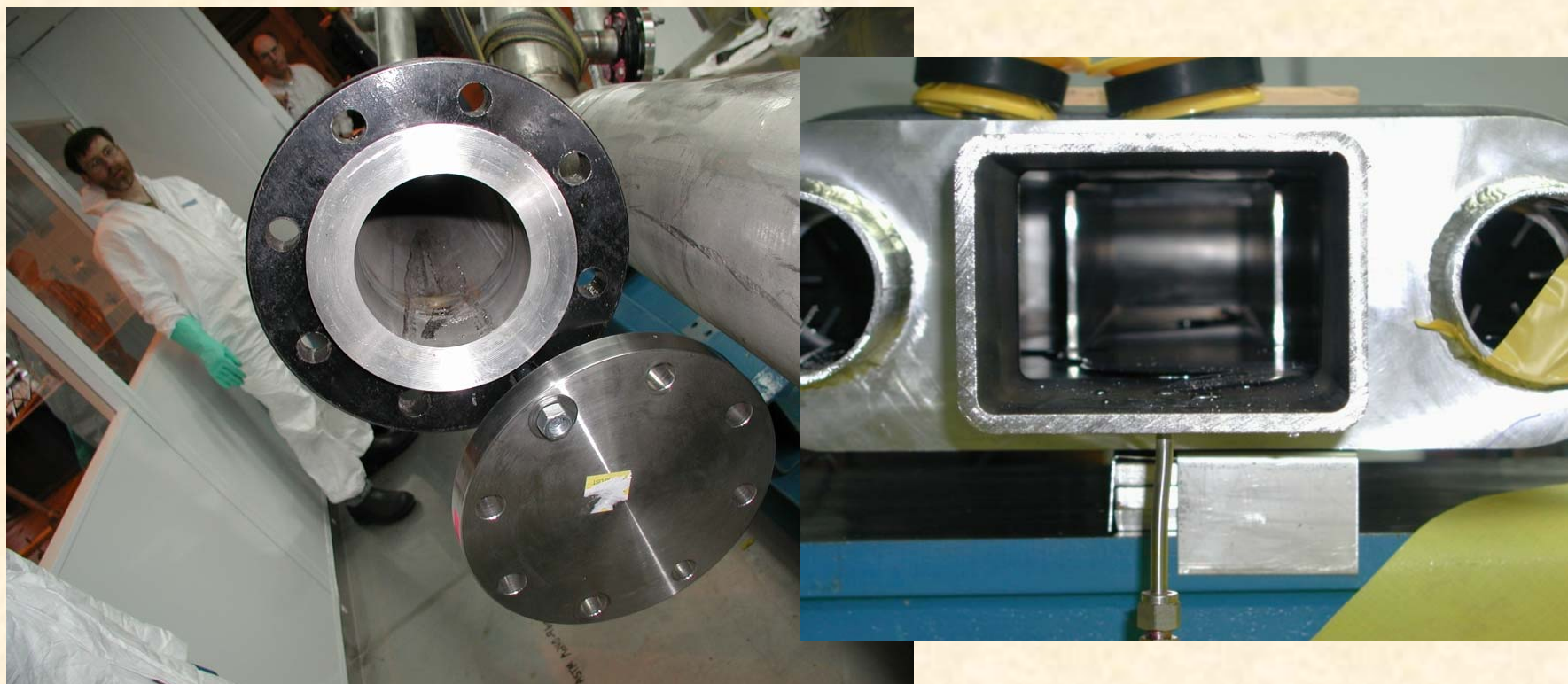

Mercury Decontamination and Cleanup – Routine Decon

- **Hg-X is a water soluble, metallic-mercury/sulfide converting powder with a chelating compound and dispersing agent**
 - **Forms a film over finely divided Hg beads, producing a non-vaporizing sulfide**
 - **Mix with water as needed**
 - **Apply with sponge**
 - **Low cost**



Mercury Decon/Cleanup (cont.)



- **HEPA Vacuum**
- **RCRA and non-RCRA waste collection**



Conclusions



- **Reviewed Hg properties and safety limits**
 - Nothing unmanageable
 - Short of an uncontained spill vapors, are the main concern
 - Use of vapor monitors, air filters, snorkel
- **Experience from operating SNS/TTF valuable for MERIT**
 - Fill MERIT with a peristaltic pump; make extensive use of spill containment; He leak check before operating
 - Vapor monitors always in use; decontamination using Hg-X and HEPA vacuum
- **Starting to develop list of off-normal events and actions**
- **Handling activated mercury requires these same precautions and procedures, but at an even higher level of alertness**