

A Short Course on Targetry for Neutrino Superbeams, Neutrino Factories and Muon Colliders

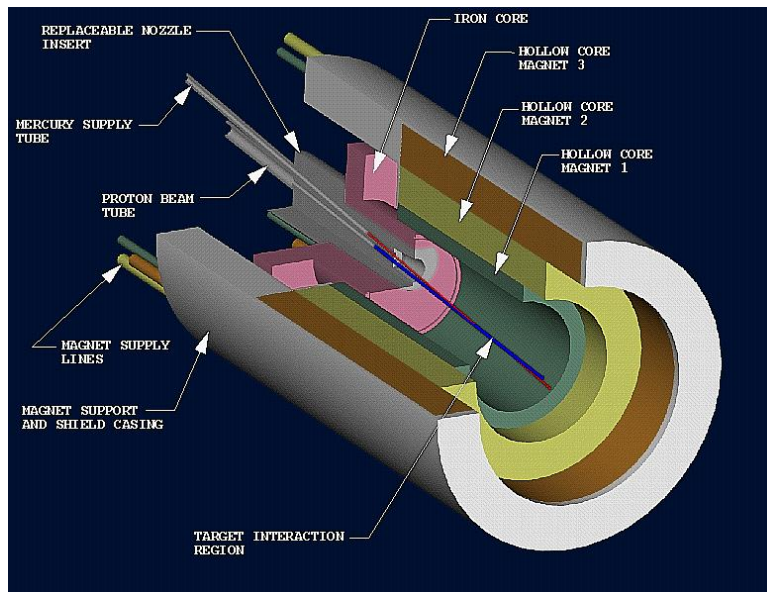
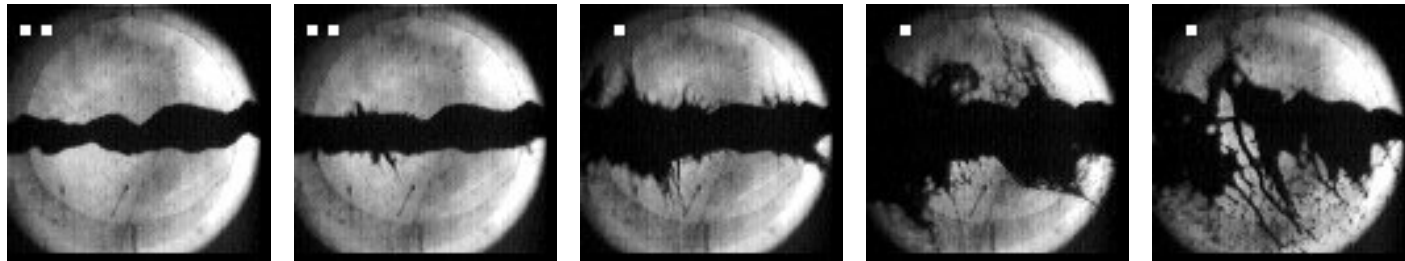

K.T. McDonald

Princeton U.

NuFact06 Summer Institute

UC Irvine, August 21, 2006

Targetry Web Page:

<http://puhep1.princeton.edu/mumu/target/>

Various Physics Examples:

<http://puhep1.princeton.edu/~mcdonald/examples/>

A Short Course on Targetry

E. Fermi: “I can calculate anything to 20% in 20 minutes.”

An everyday targetry physics question: What is the threshold intensity of sunlight to damage human skin?

[Ans: Bright sunlight, $\approx 1 \text{ kW/m}^2$.]

A metaphysics question: Why do people enjoy getting sunburned?

Why Targetry?

- **Targetry = the task of producing and capturing π 's and μ 's from proton interactions with a nuclear target.**
- **At a muon collider the key parameter is luminosity:**

$$\mathcal{L} = \frac{N_1 N_2 f}{A} \text{ s}^{-1} \text{ cm}^{-2},$$

⇒ **Gain as square of source strength (targetry),
but small beam area (cooling) is also critical.**

- **At a neutrino factory the key parameter is neutrino flux,
⇒ Source strength (targetry) is of pre-eminent concern.
[Beam cooling important mainly to be sure the beam fits in the pipe.]**
- **Since its inception the Neutrino Factory/Muon Collider Collaboration has recognized the importance of high-performance targetry, and has dedicated considerable resources towards R&D on advanced targetry concepts.**
- **The exciting results from atmospheric and reactor neutrino programs (Super-K, SNO, KamLAND) reinforce the opportunity for neutrino physics with intense accelerator neutrino beams, where targetry is a major challenge.**

Exercises

1. Give an expression for the luminosity of beams that collide with a nonzero crossing angle α .
2. A typical high-energy neutrino beam is made from the decay of π mesons that have been produced in proton interactions on a target, as sketched in the figure below.

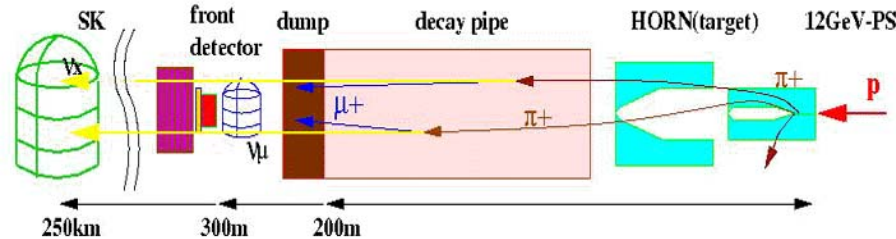

Suppose that only positively charged particles are collected by the “horn”. The main source of neutrinos is then the decay $\pi^+ \rightarrow \mu^+ \nu_\mu$.

- a. Give a simple estimate of the relative number of other types of neutrinos than ν_μ in the beam.
- b. If the decay pions have energy $E_\pi \gg m_\pi$, what is the characteristic angle θ_C of the decay neutrinos with respect to the direction of the π^+ ?
- c. If a neutrino is produced with energy $E_\nu \gg m_\pi$, what is the maximum angle $\theta_{\max}(E_\nu)$ between it and the direction of its parent pion (which can have any energy)? What is the maximum energy E_ν at which a neutrino can be produced in the decay of a pion if it appears at a given angle θ with respect to the pion’s direction?

Parts d-f explore consequences of the existence of these maxima.

- d. Deduce an analytic expression for the energy-angle spectrum $d^2N/dE_\nu d\Omega$ for neutrinos produced at angle $\theta \leq \theta_C$ to the proton beam. You may suppose that $E_\nu \gg m_\pi$, that the pions are produced with an energy spectrum $dN/dE_\pi \propto (E_p - E_\pi)^5$, where E_p is the energy of the proton beam, and that the “horn” makes all pion momenta parallel to that of the proton beam.
- e. At what energy $E_{\nu,\text{peak}}$ does the neutrino spectrum peak for $\theta = 0$?
- f. Compare the characteristics of a neutrino beam at $\theta = 0$ with an off-axis beam at angle θ such that $E_{\nu,\text{max}}(\theta)$ is less than $E_{\nu,\text{peak}}(\theta = 0)$.

Facts: $m_\pi = 139.6 \text{ MeV}/c^2$, $\tau_\pi = 26 \text{ ns}$, $m_\mu = 105.7 \text{ MeV}/c^2$, $\tau_\mu = 2.2 \text{ } \mu\text{s}$. In this problem, neutrinos can be taken as massless.

See, <http://puhep1.princeton.edu/~mcdonald/examples/offaxisbeam.pdf>

High-Power Targets Essential for Many Future Facilities

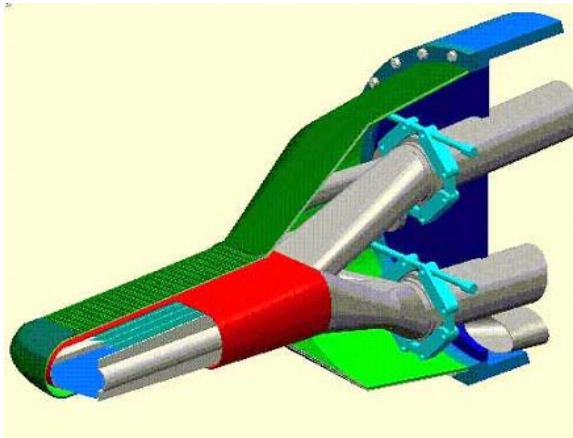

ESS

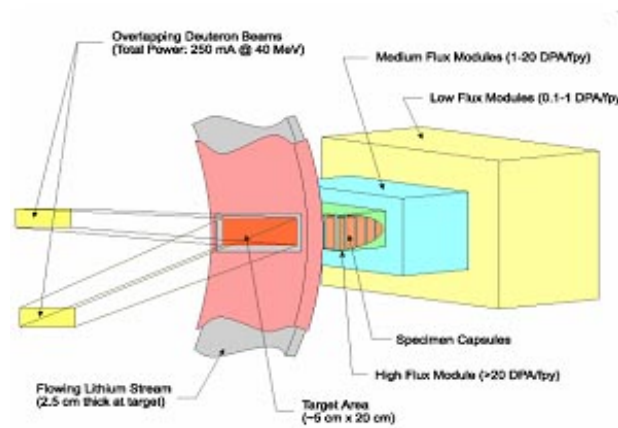

IFMIF

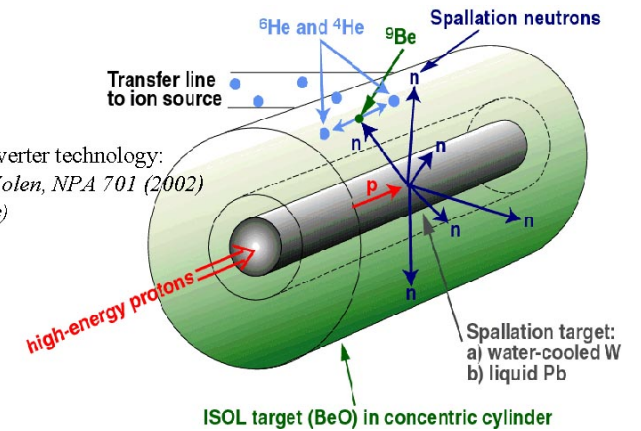

Converter technology:
(J. Nolen, NPA 701 (2002) 312c)

ISOL target (BeO) in concentric cylinder

ISOL/ β Beams

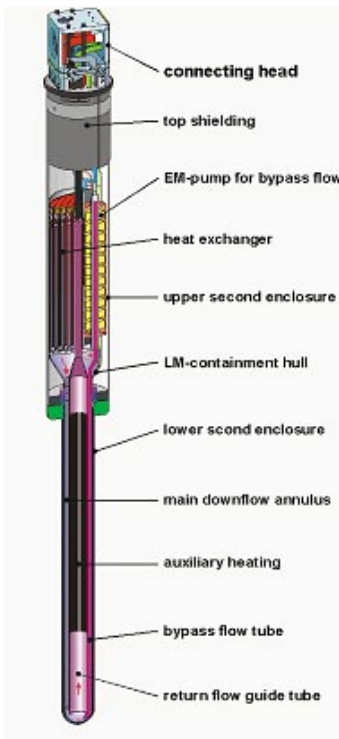

PSI

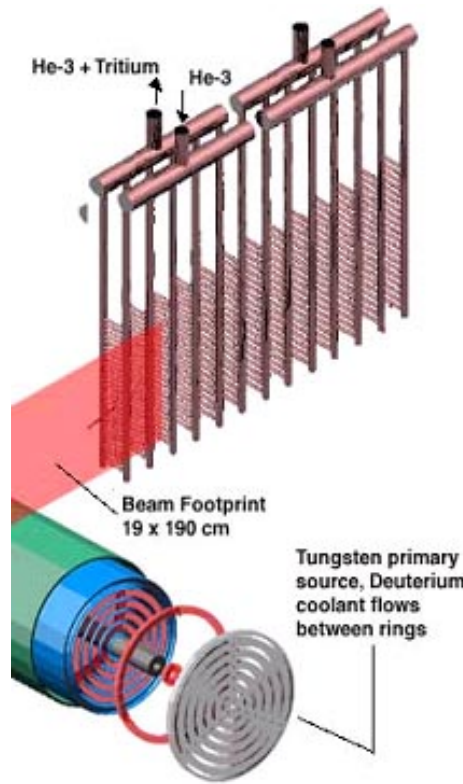

APT

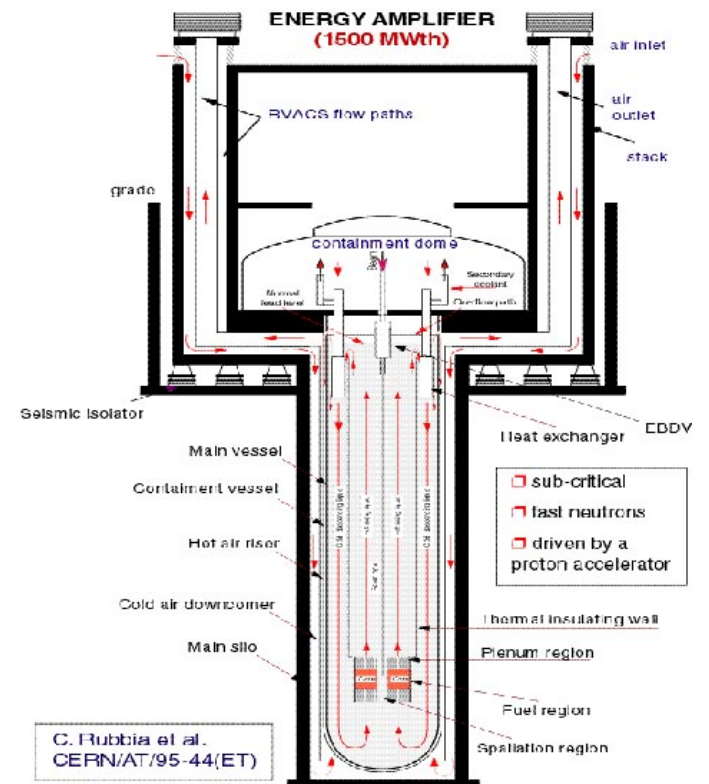

C. Rubbia et al.
CERN/AT/95-44(ET)

ATW

4-MW Proton Beam

- **10-30 GeV** appropriate for both Superbeam and Neutrino Factory.
⇒ $0.8-2.5 \times 10^{15}$ pps; $0.8-2.5 \times 10^{22}$ protons per year of 10^7 s.
 - **Rep rate 15-50 Hz** at Neutrino Factory, as low as **2 Hz** for Superbeam.
⇒ Protons per pulse from 1.6×10^{13} to 1.25×10^{15} .
⇒ Energy per pulse from 80 kJ to 2 MJ.
 - **Small beam size preferred:**
≈ 0.1 cm^2 for Neutrino Factory, ≈ 0.2 cm^2 for Superbeam.
- ⇒ **Severe materials issues for target AND beam dump.**
- **Radiation Damage.**
 - **Melting.**
 - **Cracking** (due to single-pulse “thermal shock”).

Radiation Damage

The lifetime dose against radiation damage (embrittlement, cracking,) by protons for most solids is about $10^{22}/\text{cm}^2$.

⇒ Target lifetime of about 5-14 days at a Neutrino Factory (and 9-28 days at a Superbeam).

⇒ Mitigate by frequent target changes, moving target, liquid target, ...

Remember the Beam Dump

Target of 2 interaction lengths ⇒ 1/7 of beam is passed on to the beam dump.

Long distance from target to dump at a Superbeam,

⇒ Beam is much less focused at the dump than at the target,

⇒ Radiation damage to the dump not a critical issue (Superbeam).

Short distance from target to dump at a Neutrino Factory,

⇒ Beam still tightly focused at the dump,

⇒ Frequent changes of the beam dump, or a moving dump, or a liquid dump.

A liquid beam dump is the most plausible option for a Neutrino Factory, independent of the choice of target. (This is so even for a 1-MW Neutrino Factory.)

The proton beam should be tilted with respect to the axis of the capture system at a Neutrino Factory, so that the beam dump does not absorb the captured π 's and μ 's.

Target and Capture Topologies: Toroidal Horn

The traditional topology for efficient capture of secondary pions is a toroidal “horn” (Van der Meer, 1961).

- Collects only one sign, \Rightarrow Long data runs, but nonmagnetic detector (Superbeam).
- Inner conductor of toroid very close to proton beam.
 - \Rightarrow Limited life due to radiation damage at 4 MW.
 - \Rightarrow Beam, and beam dump, along magnetic axis.
 - \Rightarrow More compatible with Superbeam than with Neutrino Factory.

Carbon composite target with He gas cooling (BNL study):

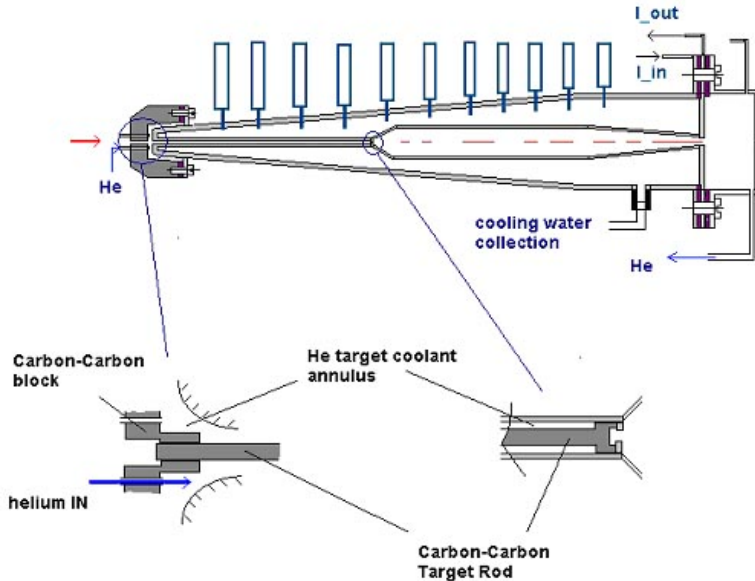

Mercury jet target (CERN SPL study):

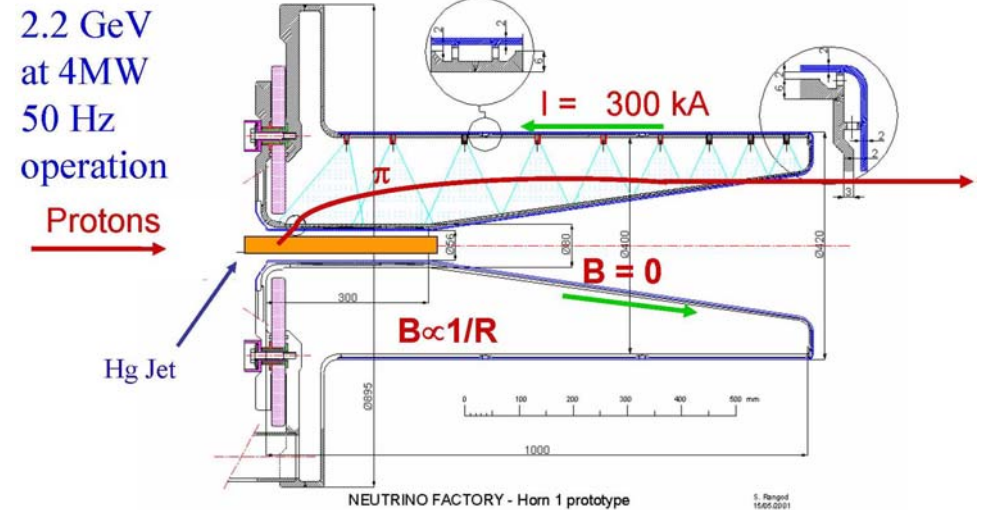

If desire secondary pions with $E_\pi \lesssim 5$ GeV (Neutrino Factory), a high- Z target is favored, but for $E_\pi \gtrsim 10$ GeV (some Superbeams), low Z is preferred.

Target and Capture Topologies: Solenoid

Palmer (1994) proposed a solenoidal capture system for a Neutrino Factory.

- Collects both signs of π 's and μ 's, \Rightarrow Shorter data runs (with magnetic detector).
- Solenoid coils can be some distance from proton beam.

$\Rightarrow \gtrsim 4$ year life against radiation damage at 4 MW.

\Rightarrow Proton beam readily tilted with respect to magnetic axis.

\Rightarrow Beam dump out of the way of secondary π 's and μ 's.

Mercury jet target and proton beam tilt downwards with respect to the horizontal magnetic axis of the capture system.

The mercury collects in a pool that serves as the beam dump (Neutrino Factory Study 2):

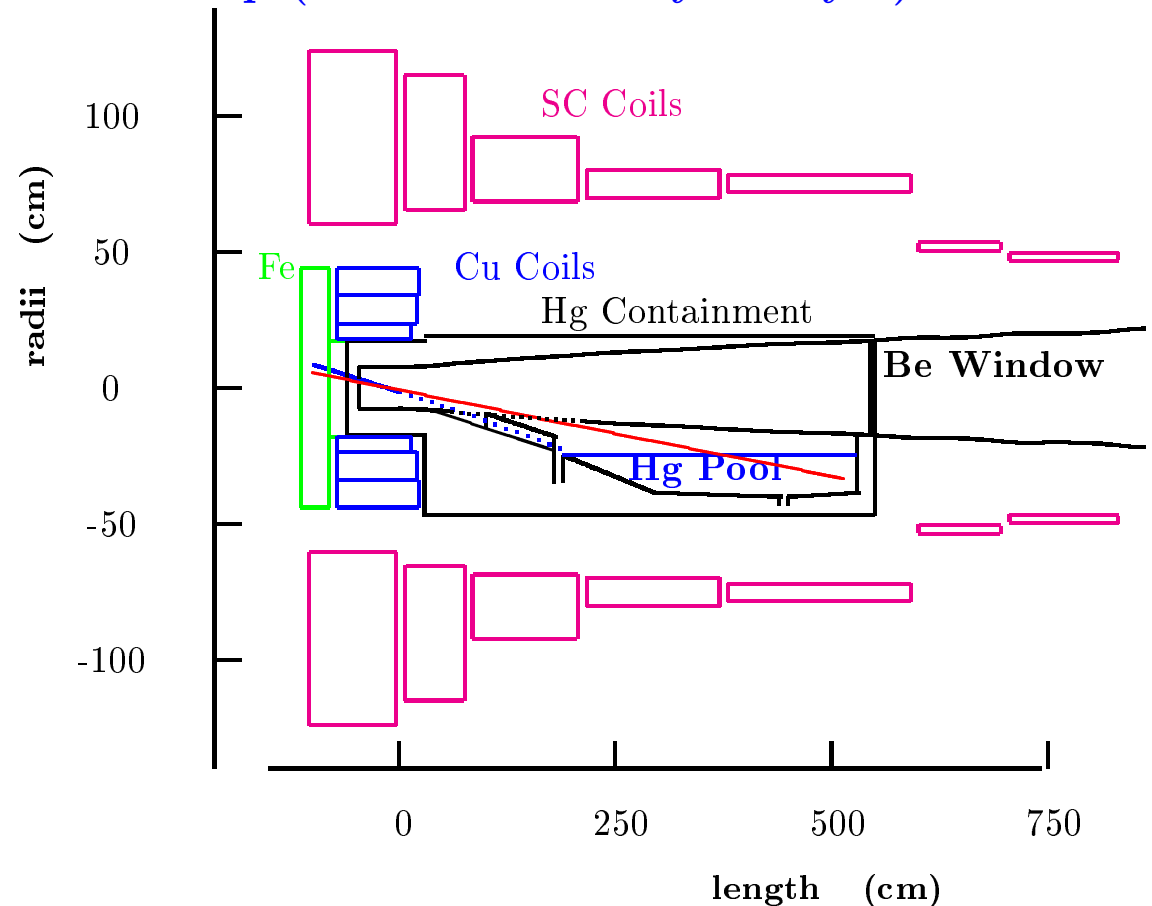

Exercises

3. A charged particle moves in a plane perpendicular to a uniform magnetic field \mathbf{B} . Show that if \mathbf{B} changes slowly with time, the magnetic moment produced by the orbital motion of the charge remains constant. Show also that the magnetic flux through the orbit, $\Phi = \pi r^2 B$ is constant. These results are sometimes given the fancy name of adiabatic invariants of the motion.

See, prob. 1a of <http://puhep1.princeton.edu/~mcdonald/examples/ph501set5.pdf>

4. The Magnetic Mirror. Suppose instead, that the magnetic field is slightly non-uniform such that B_z increases with z . Then, if the charged particle has a small velocity in the z direction, it slowly moves into a stronger field. Again, we would expect the flux through the orbit to remain constant, which means that the orbital radius must decrease and the orbital velocity must increase. However, magnetic fields which are constant in *time* cannot change the magnitude of the velocity, therefore v_z must decrease. If B_z increases enough, v_z will go to zero, and the particle is “trapped” by the magnetic field. Write

$$v^2 = v_z^2 + v_{\perp}^2 = v_0^2, \quad (1)$$

where v_{\perp} is the orbital velocity and v_0 is constant. Use the result of exercise 3 to show that

$$v_z^2(z) \approx v_0^2 - v_{\perp}^2(0) \frac{B_z(z)}{B_z(0)}. \quad (2)$$

Suppose a particle is created on the axis of a cylindrically symmetric magnetic field $B_z(z)$ with initial longitudinal momentum P_{z0} and initial transverse momentum $P_{\perp,0}$ at a point where the field strength is B_0 . What are the longitudinal and transverse momenta of the particle, and the radius of its helical trajectory, as a function of z as it moves adiabatically through the field.

(Since B_z varies with z , there must also be a radial component B_r to the field, according to $\nabla \cdot \mathbf{B} = 0$. In the adiabatic approximation, one ignores the small radial field component.)

See, prob. 1b of <http://puhep1.princeton.edu/~mcdonald/examples/ph501set5.pdf>

Exercise

5. Consider particle with charge e and momentum $\mathbf{P} = P_z + \mathbf{P}_\perp$ ($P_\perp \neq 0$) that is moving on average in the z direction inside a solenoid magnet whose symmetry axis is the z axis and whose magnetic field strength is B_z . Inside the solenoid, the particle's trajectory is a helix of radius R , whose center is at distance R_0 from the magnet axis.

The longitudinal momentum P_z is so large that when the particle reaches the end of the solenoid coil, it exits the field with little change in its transverse coordinates. This behavior is far from the adiabatic limit in which the trajectory spirals around a field line.

When the particle exits the solenoid, the radial component of the magnetic “fringe” field exerts azimuthal forces on the particle, and, in general, leaves it with a nonzero azimuthal momentum, P_ϕ . Deduce a condition on the motion of the particle when within the solenoid, *i.e.*, on R , R_0 , P_z , P_\perp , and B_z , such that the azimuthal momentum vanishes as the particle leaves the magnetic field region. Your result should be independent of the azimuthal phase of the trajectory when it reaches the end of the solenoid coil.

Hint: Consider the canonical momentum and/or angular momentum.

Answer: The particle has zero canonical angular momentum if and only if its trajectory passes through the magnetic axis.

This result shows that a solenoid can act as a lens – for particles of a given momentum. For example, if the particles are created in a target that lies on the magnetic axis, they will have zero azimuthal momentum, $P_\phi = 0$, after they leave the magnet. If they also have zero radial momentum, $P_r = 0$, then the particles would form a parallel beam, and we could say that the target was at a focus of the solenoid “lens”.

The radial momentum is unchanged as the particle leaves the magnet (in the “impulse approximation” that the solenoid field drops quickly to zero at the edge of the magnet). Hence, the particles will be focused into a parallel beam if they have zero radial momentum when they reach the edge of the magnet.

Note that if the particles execute exactly $1/2$ revolution (or $(2n + 1)/2$ revolutions) on their helical trajectories while in the magnet, their initial radial momentum P_r is completely transformed into (mechanical) azimuthal momentum $P_{\phi,M}$ (which is equal and opposite to the azimuthal electromagnetic momentum, so that the canonical azimuthal momentum is zero); the radial momentum is now zero as desired. Since the cyclotron frequency of the helical motion is $\omega = eB_z/mc$, the distance L from the target to the edge of the solenoid should be $L = v_z \Delta t = (2n + 1)\pi v_z / \omega = (2n + 1)\pi m v_z c / e B_z = (2n + 1)\pi c P_z / e B_z$. Thus, the solenoid is “focusing” only for particles of (odd multiples of) a particular longitudinal momentum.

See, <http://puhep1.princeton.edu/~mcdonald/examples/canon.pdf>

http://puhep1.princeton.edu/~mcdonald/examples/solenoid_lens.pdf

A Neutrino Horn Based on a Solenoid Lens

- Pions produced on axis inside the (uniform) solenoid have zero canonical angular momentum, $L_z = r(P_\phi + eA_\phi/c) = 0, \Rightarrow P_\phi = 0$ on exiting the solenoid.
- If the pion has made exactly 1/2 turn on its helix when it reaches the end of the solenoid, then its initial P_r has been rotated into a pure P_ϕ , $\Rightarrow P_\perp = 0$ on exiting the solenoid.

\Rightarrow Point-to-parallel focusing for

$$P_\pi = eBd/(2n + 1)\pi c.$$

\Rightarrow Narrowband (less background) neutrino beams of energies

$$E_\nu \approx \frac{P_\pi}{2} = \frac{eBd}{(2n + 1)2\pi c}.$$

\Rightarrow Can study several neutrino oscillation peaks at once,

$$\frac{1.27M_{23}^2[\text{eV}^2] L[\text{km}]}{E_\nu[\text{GeV}]} = \frac{(2n + 1)\pi}{2}.$$

(Marciano, hep-ph/0108181)

NuFACT06: See report by H. Kirk and R. Palmer on solenoid “horns”.

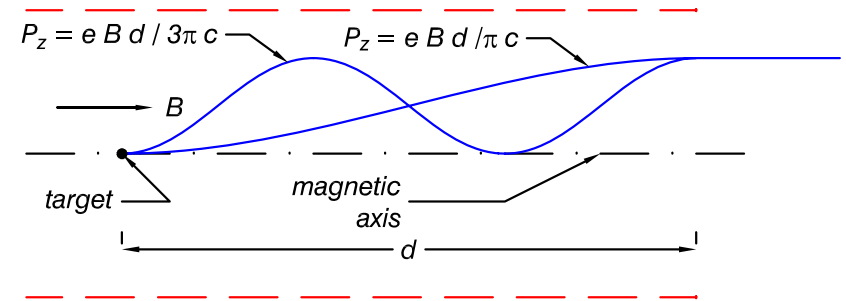
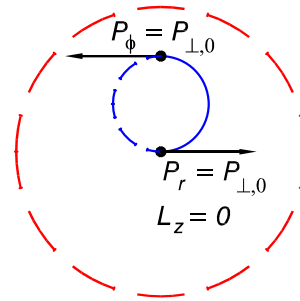

(KTM, physics/0312022)

Study both ν and $\bar{\nu}$ at the same time.

\Rightarrow Detector must identify sign of μ and e .

\Rightarrow Magnetized liquid argon TPC.

(astro-ph/0105442).

Thermal Issues for Solid Targets (Superbeams), I

The quest for efficient capture of secondary pions precludes traditional schemes to cool a solid target by a liquid. (Absorption by plumbing; cavitation of liquid.)

A solid, radiation-cooled stationary target in a 4-MW beam will equilibrate at about 2500 C. \Rightarrow Carbon is only candidate for this type of target.

(Carbon target must be in He atmosphere to suppress sublimation.)

A moving band target (tantalum) could be considered (if capture system is toroidal).

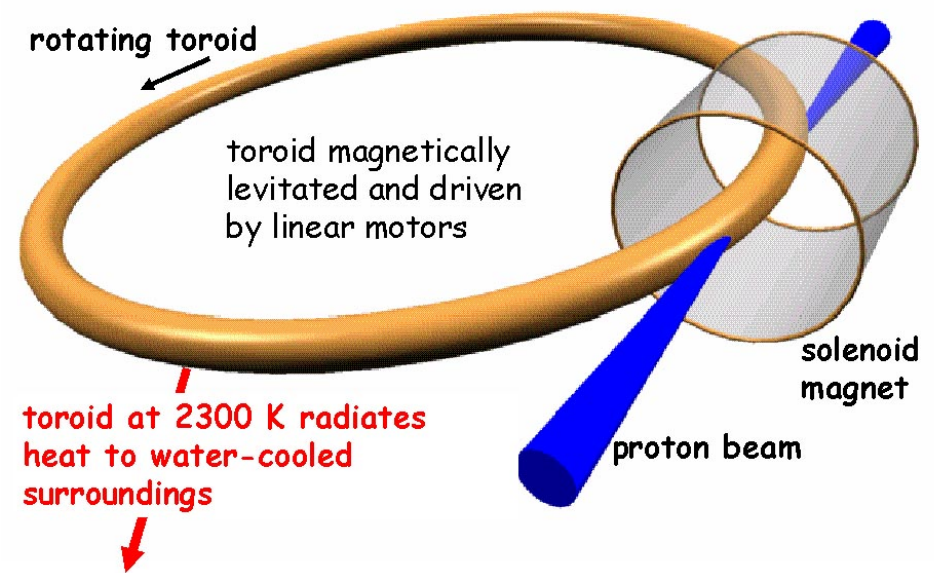
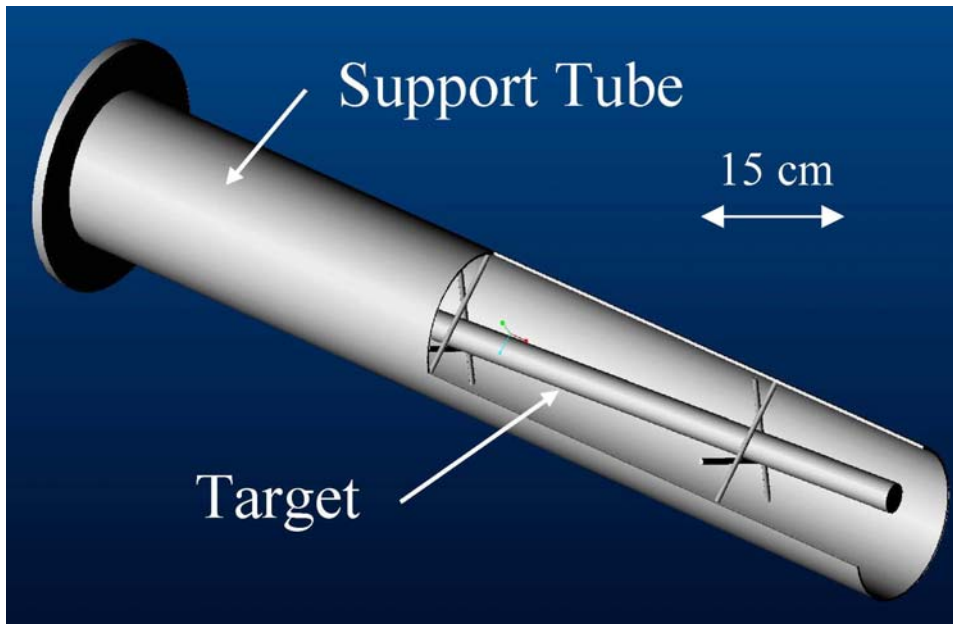

Thermal Issues for Solid Targets (Superbeams), II

When beam pulse length t is less than target radius r divided by speed of sound v_{sound} , beam-induced pressure waves (thermal shock) are a major issue.

Simple model: if U = beam energy deposition in, say, Joules/g, then the instantaneous temperature rise ΔT is given by

$$\Delta T = \frac{U}{C}, \quad \text{where } C = \text{heat capacity in Joules/g/K.}$$

The temperature rise leads to a strain $\Delta r/r$ given by

$$\frac{\Delta r}{r} = \alpha \Delta T = \frac{\alpha U}{C}, \quad \text{where } \alpha = \text{thermal expansion coefficient.}$$

The strain leads to a stress P (= force/area) given by

$$P = E \frac{\Delta r}{r} = \frac{E \alpha U}{C}, \quad \text{where } E = \text{modulus of elasticity.}$$

In many metals, the tensile strength obeys $P \approx 0.002E$, $\alpha \approx 10^{-5}$, and $C \approx 0.3 \text{ J/g/K}$, in which case

$$U_{\text{max}} \approx \frac{PC}{E\alpha} \approx \frac{0.002 \cdot 0.3}{10^{-5}} \approx 60 \text{ J/g.}$$

⇒ Best candidates for solid targets have high strength (Vasomax, Inconel, TiAl6V4) and/or low thermal expansion (Superinvar, Toyota “gum metal”, carbon-carbon composite).

Exercises: How Much Beam Power Can a Solid Target Stand?

6. Estimate C , α , E and the tensile strength P using a simplified model of atoms.

7. How many protons are required to deposit 60 J/g in a material?

What is the maximum beam power this material can withstand without cracking, for a 10-GeV beam at 10 Hz with area 0.1 cm^2 .

Ans: If we ignore “showers” in the material, we still have dE/dx ionization loss, of about 1.5 MeV/g/cm^2 .

Now, $1.5 \text{ MeV} = 2.46 \times 10^{-13} \text{ J}$, so 60 J/g requires a proton beam intensity of $60/(2.4 \times 10^{-13}) = 2.4 \times 10^{14}/\text{cm}^2$.

So, $P_{\text{max}} \approx 10 \text{ Hz} \cdot 10^{10} \text{ eV} \cdot 1.6 \times 10^{-19} \text{ J/eV} \cdot 2.4 \times 10^{14}/\text{cm}^2 \cdot 0.1 \text{ cm}^2 \approx 4 \times 10^5 \text{ J/s} = 0.4 \text{ MW}$.

If solid targets crack under singles pulses of 60 J/g , then safe up to only 0.4 MW beam power!

Empirical evidence is that some materials survive $500\text{-}1000 \text{ J/g}$,
 \Rightarrow May survive 4 MW if rep rate $\gtrsim 10 \text{ Hz}$.

Ni target in FNAL $p\bar{b}$ ar source:
 “damaged but not failed” for peak energy deposition of 1500 J/g .



A Carbon Target is Feasible at 1-MW Beam Power

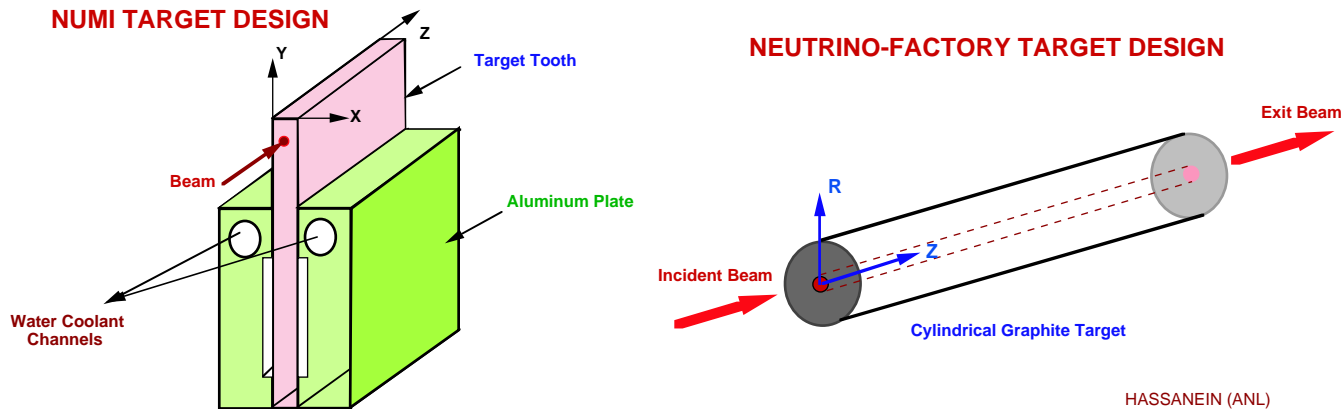

HASSANEIN (ANL)

A carbon-carbon composite with near-zero thermal expansion is largely immune to beam-induced pressure waves.

A carbon target in vacuum sublimates away in 1 day at 4 MW.

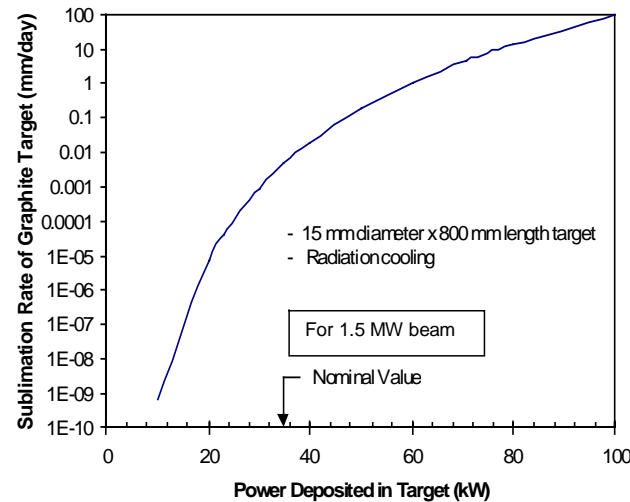

Sublimation of carbon is negligible in a helium atmosphere.

Radiation damage is limiting factor: ≈ 12 weeks at 1 MW.

Exercises

8. What is the equilibrium temperature of a carbon target of 1-cm-diameter as a function of beam power, assuming only radiation cooling?

Ans:

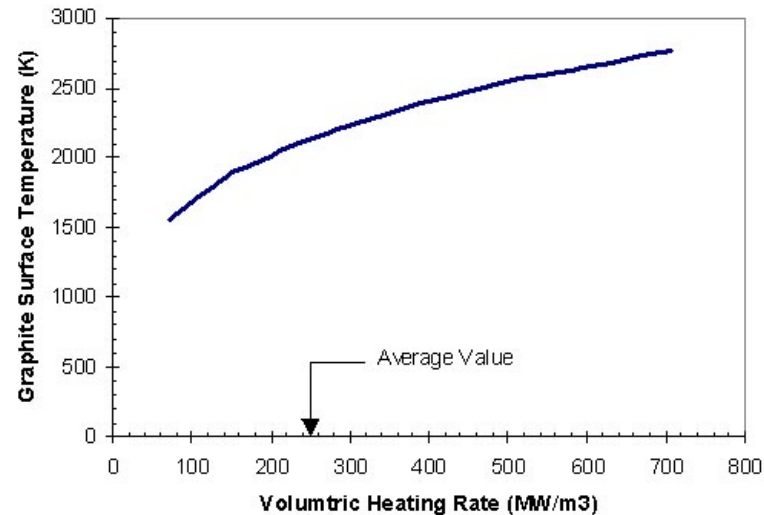

From http://www.hep.princeton.edu/mumu/catalina/Catalina_Mtg.ppt

9. What is the radiation damage limit of materials?

Ans: Materials turn to powder due to radiation damage once each atom has suffered \approx one nuclear interaction \equiv 1 DPA (displacement per atom).

The displacements are due to \approx 10-MeV neutrons.

In a thick target (\gtrsim 1 nuclear interaction length) have \approx 10 10-MeV neutrons per beam proton.

$$\sigma_{np} \approx 4\pi\lambda^2 \approx 10^{-25} \text{ cm}^2; \sigma_{nA} \approx 10\sigma_{np} \approx 10^{-24} \text{ cm}^2.$$

\Rightarrow Need $\approx 10^{23}$ protons/cm² for 1 DPA.

Empirical result: more like 10^{22} /cm² for 1 DPA.

Ex: If 10 Hz of 10^{15} protons/pulse into 0.1 cm², need only 10^5 pulses = 1 day for catastrophic radiation damage.

Lower Thermal Shock If Lower Thermal Expansion Coefficient

ATJ graphite and a 3-D weave of carbon-carbon fibers instrumented with fiberoptic strain sensors, and exposed to pulses of 4×10^{12} protons @ 24 Gev.

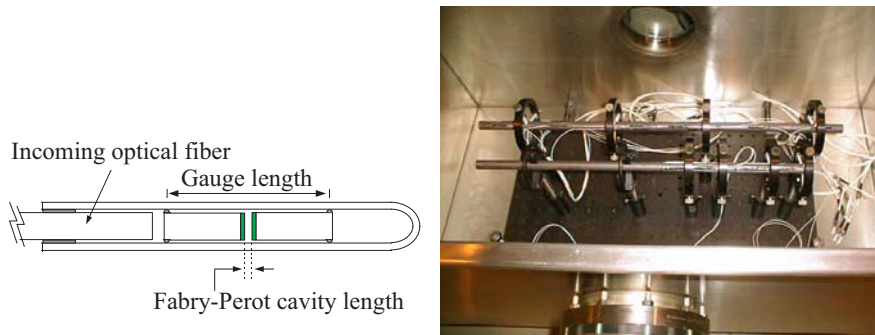

BNL E951 Target Experiment
24 GeV 3.0 e12 proton pulse on Carbon-Carbon and ATJ graphite targets
Recorded strain induced by proton pulse

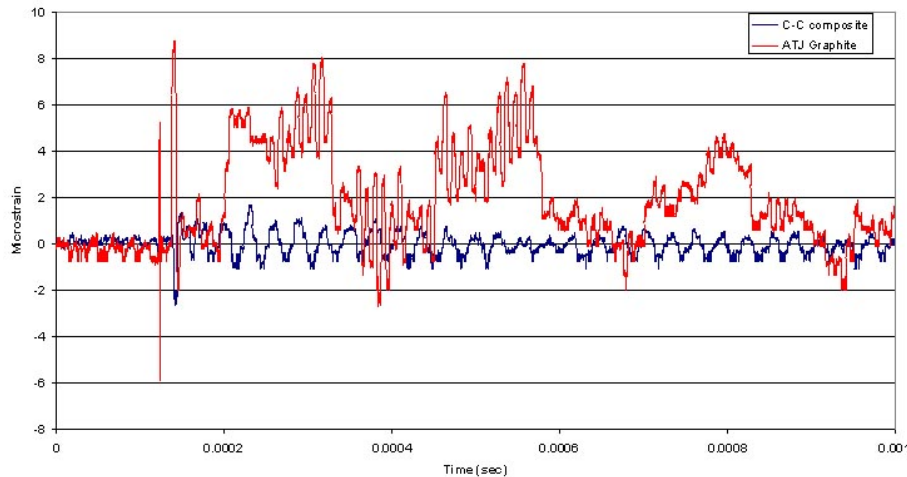

Carbon-carbon composite showed much lower strains than in the ordinary graphite.

Thermal expansion coefficient of engineered materials is affected by radiation.

Super-Invar: CTE vs. dose:

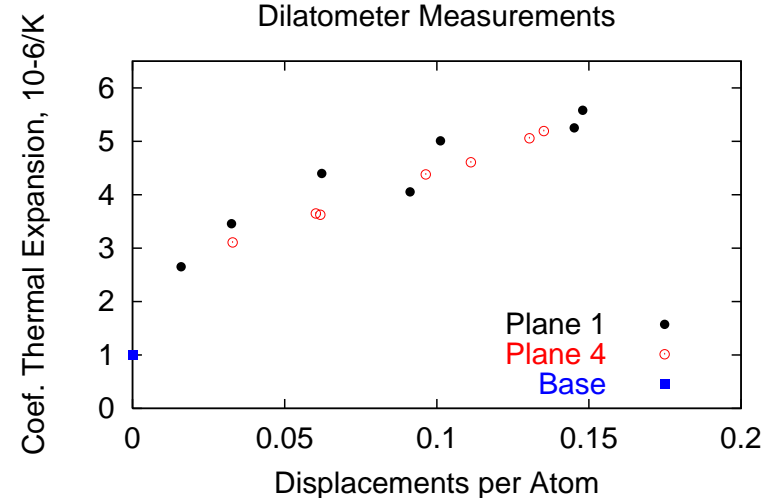

Super-Invar: recovery of the CTE by thermal annealing:

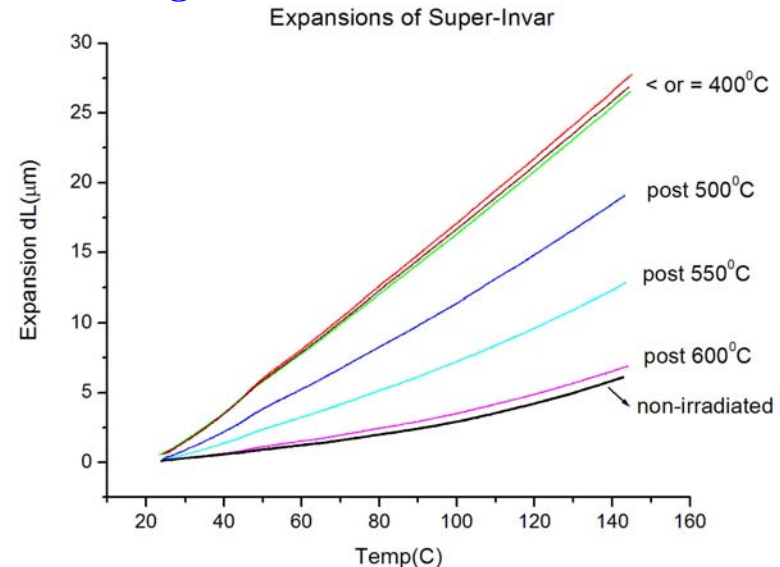

Thermal Issues for Liquid Targets (Neutrino Factory)

Liquid target/dump using mercury, or a Pb-Bi alloy.

$\approx 400 \text{ J/gm}$ to vaporize Hg (from room temp),

\Rightarrow Need flow of $> 10^4 \text{ g/s} \approx 1 \text{ l/s}$ in target/dump to avoid boiling in a 4-MW beam.

Neutrino Factory Study 2 design has 1.5 l/s flow of Hg, so no critical thermal issues.

Energy deposited in the mercury target (and dump) will cause dispersal, but at benign velocities (10-50 m/s).

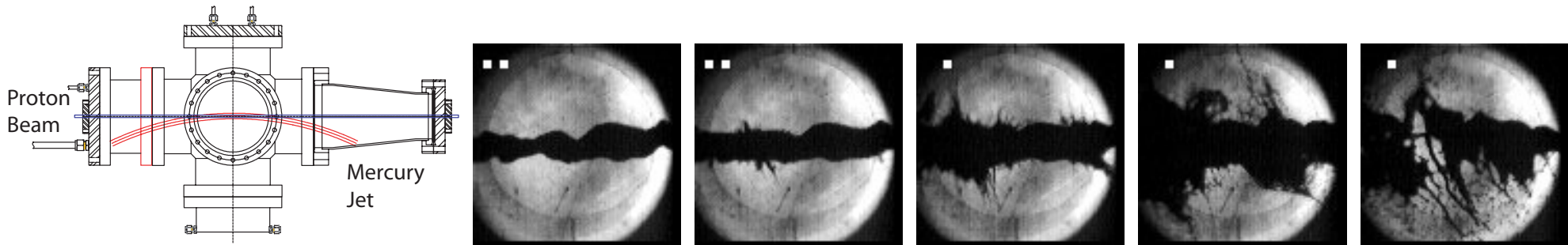

1-cm-diameter Hg jet in $2e12$ protons at $t = 0, 0.75, 2, 7, 18 \text{ ms}$ (BNL E-951, 2001).

Model (Sievers):
$$v_{\text{dispersal}} = \frac{\Delta r}{\Delta t} = \frac{r\alpha\Delta T}{r/v_{\text{sound}}} = \frac{\alpha U}{C} v_{\text{sound}} \approx 12.5 \text{ m/s for } U \approx 25 \text{ J/g.}$$

Data: $v_{\text{dispersal}} \approx 10 \text{ m/s for } U \approx 25 \text{ J/g.}$

Pion/Muon Yield

For $E_p \gtrsim 10$ GeV, more yield with high- Z target (MARS calculations).

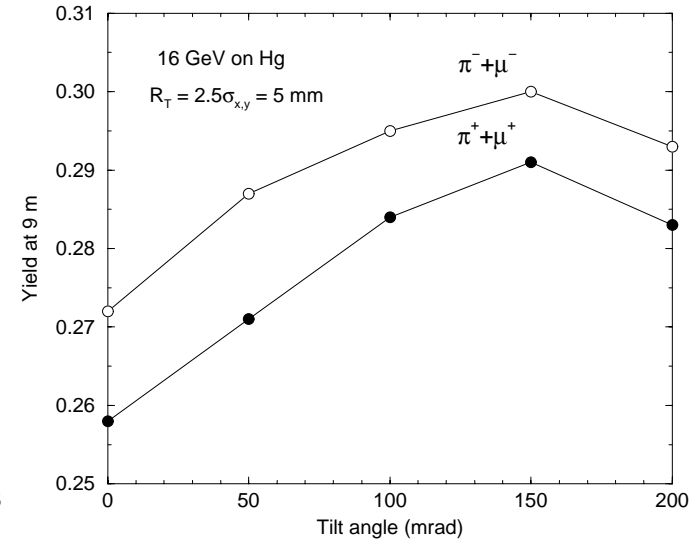
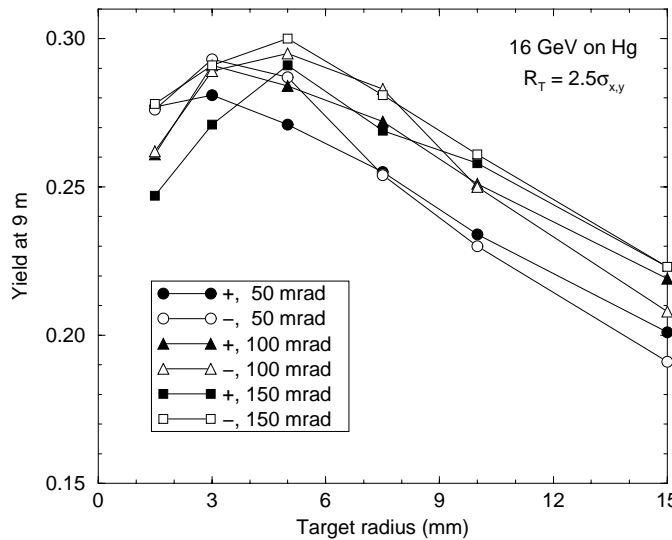
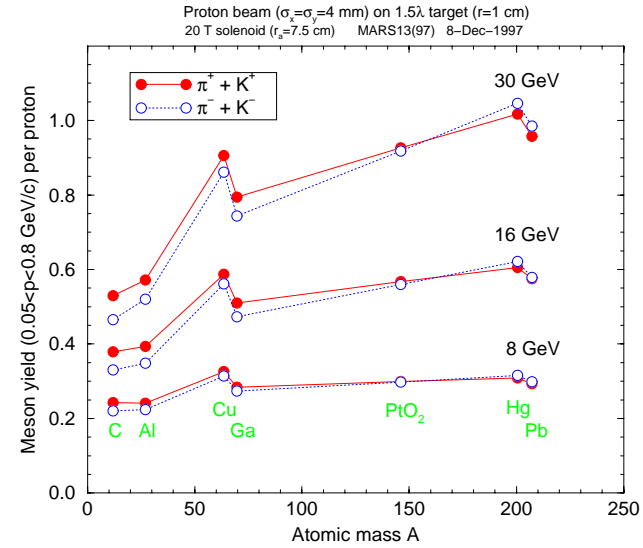

Mercury target radius should be ≈ 5 mm,
 with target axis tilted by ≈ 100 mrad to the magnetic axis.

Can capture ≈ 0.3 pion per proton with $50 < P_\pi < 400$ MeV/c.

20-T Capture Magnet System

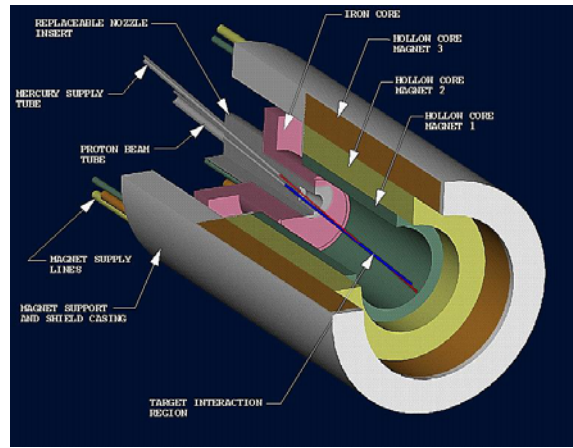

Inner, hollow-conductor copper coils generate 6 T @ 12 MW:

Bitter-coil option less costly, but marginally feasible.

Outer, superconducting coils generate 14 T @ 600 MJ:

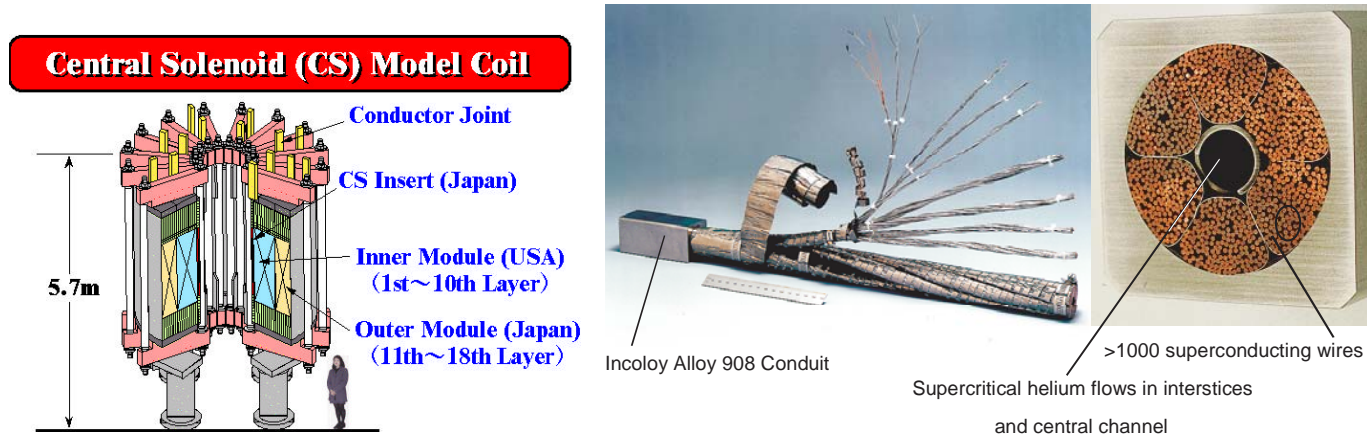

Cable-in-conduit construction similar to ITER central solenoid.

Both coils shielded by tungsten-carbide/water.

Target System Support Facility

Extensive shielding; remote handling capability.

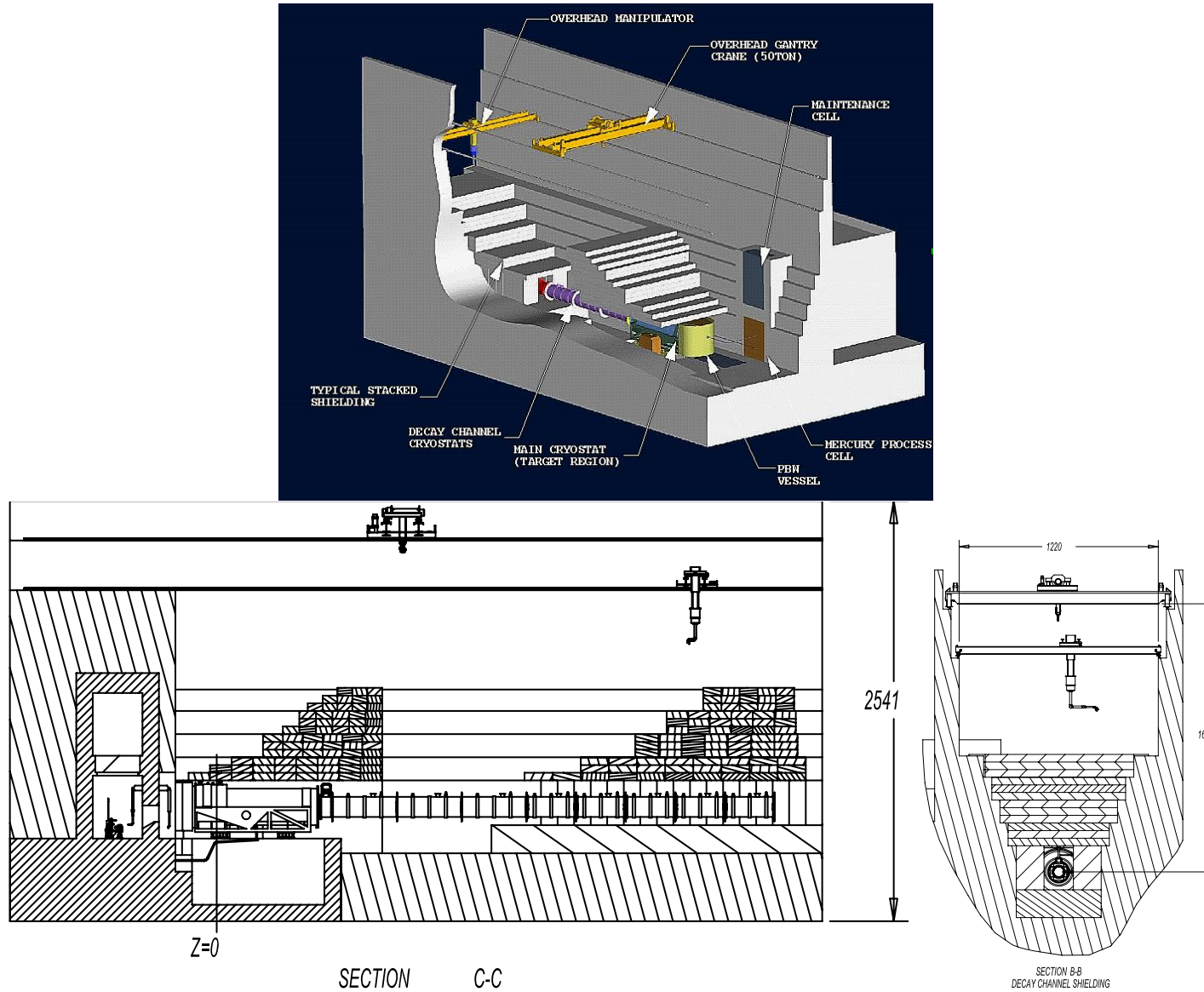

Lifetime of Components in the High Radiation Environment

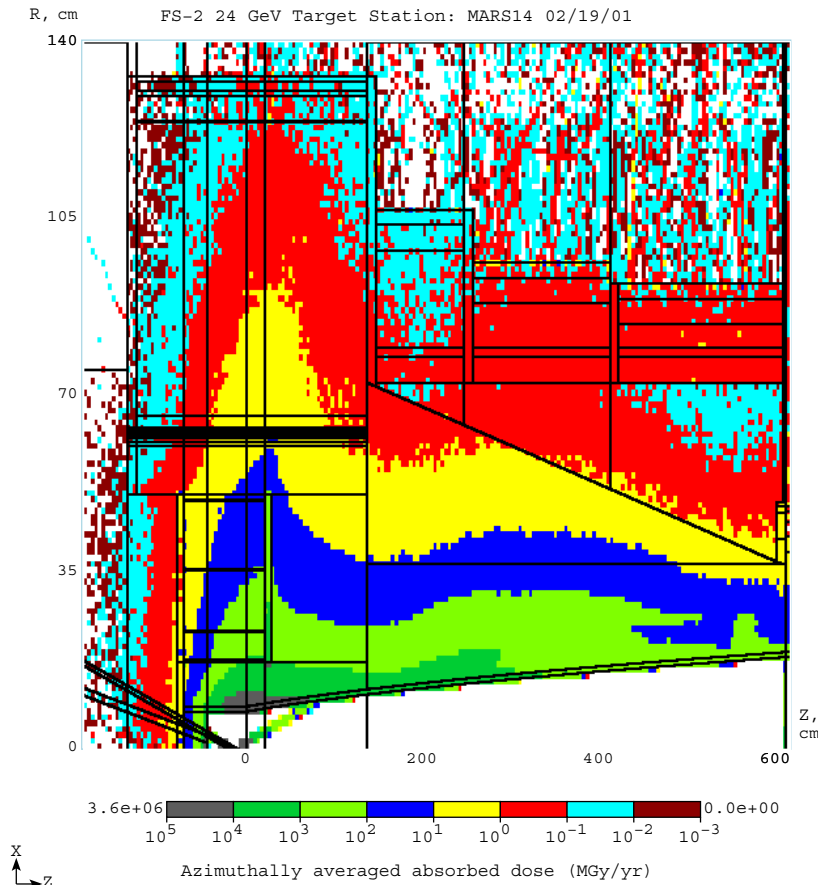

Some components must be replaceable.

Component	Radius (cm)	Dose/yr (Grays/ 2×10^7 s)	Max allowed Dose (Grays)	1 MW Life (years)	4 MW life (years)
Inner shielding	7.5	5×10^{10}	10^{12}	20	5
Hg containment	18	10^9	10^{11}	100	25
Hollow conductor coil	18	10^9	10^{11}	100	25
Superconducting coil	65	5×10^6	10^8	20	5

Issues for Liquid Jet Targets

1. Hydrodynamics. 2. Magnetic effects. 3. Beam-induced effects.



A. Calder, Paris (1937):



Hydrodynamics of Liquid Jet Targets

- **Diameter $d = 1$ cm.**
- **Velocity $v = 20$ m/s.**
- **The volume flow rate of mercury in the jet is**

$$\begin{aligned} \text{Flow Rate} = vA &= 2000 \text{ cm/s} \cdot \frac{\pi}{4} d^2 = 1571 \text{ cm}^3/\text{s} = 1.57 \text{ l/s} = 0.412 \text{ gallon/s} \\ &= 94.2 \text{ l/min} = 24.7 \text{ gpm.} \end{aligned} \quad (3)$$

- **The power in the jet (associated with its kinetic energy) is**

$$\text{Power} = \frac{1}{2} \rho \cdot \text{Flow Rate} \cdot v^2 = \frac{13.6 \times 10^3}{2} \cdot 0.00157 \cdot (20)^2 = 4270 \text{ W} = 5.73 \text{ hp.} \quad (4)$$

- **To produce the 20-m/s jet into air/vacuum out of a nozzle requires a pressure**

$$\text{Pressure} = \frac{1}{2} \rho v^2 = 27.2 \text{ atm} = 410 \text{ psi}, \quad (5)$$

IF no dissipation of energy.

- **The mercury jet flow is turbulent: the viscosity is $\mu_{\text{Hg}} = 1.5$ cP (kinematic viscosity $\eta = \mu/\rho = 0.0011$ cm²/s), so the Reynolds number is**

$$\mathcal{R} = \frac{\rho dv}{\mu} = \frac{dv}{\eta} = 1.8 \times 10^6. \quad (6)$$

- **The surface tension of mercury is $\tau = 465$ dyne/cm (water = 73), \Rightarrow**

$$\text{Weber number, } \mathcal{W} = \frac{\rho dv^2}{\tau} = 115,000. \quad (7)$$

Nozzle Lore

Leach & Walker (1966):

Hg jet for Neutrino Factory:
 $v = 20 \text{ m/s}$, $d = 1 \text{ cm}$,
 \Rightarrow Turbulent flow.

Lore:

- Should be able to make a 1-cm-diameter Hg jet go 1-2 m before breakup.
- Area of feed should be $\gtrsim 10\times$ area of nozzle.
- $\approx 15^\circ$ nozzle taper is good.
- Nozzle tip should be straight, with $\approx 3:1$ aspect ratio.
- High-speed jets will have a halo of spray around a denser core.
- Low/zero surrounding gas pressure is better.

McCarthy & Molloy (1974):

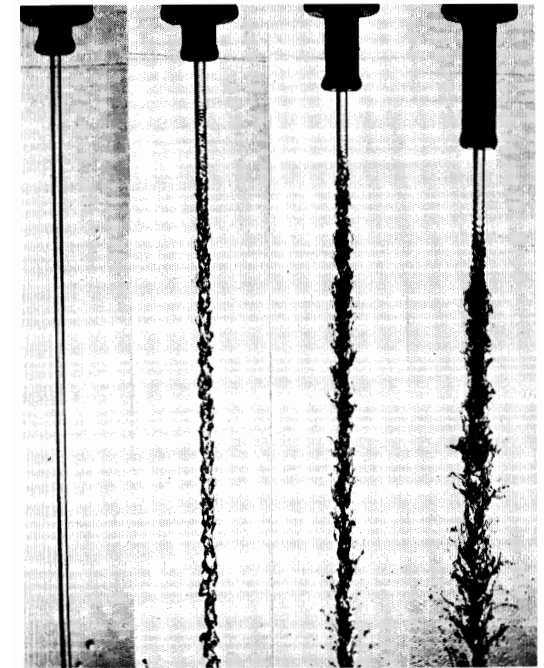
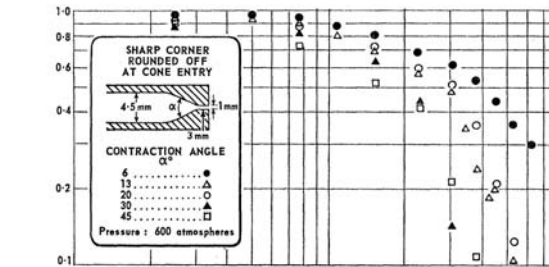
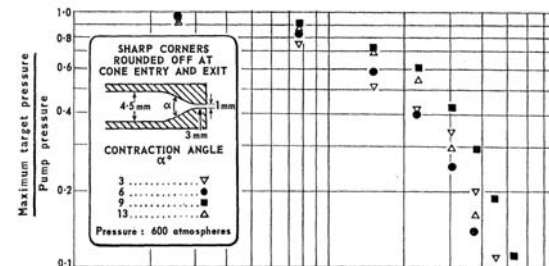

Fig. 5. Effect of nozzle design on the stability of glycerol-water jets.

Jet viscosity 11 cP
 Jet velocity 20 m s^{-1} (approx.)
 Nozzle diameter 2.54 mm
 Jet Reynolds no. 4750
 Jet Ohnesorge no. 0.026
 Exposure $30 \mu\text{sec}$
 Nozzle aspect ratio $AR = L/d$ (see Fig. 7) = 0, 1, 5, 10 L to R.



(a) Rounded inlet corners



(b) Rounded corners at both ends of contraction

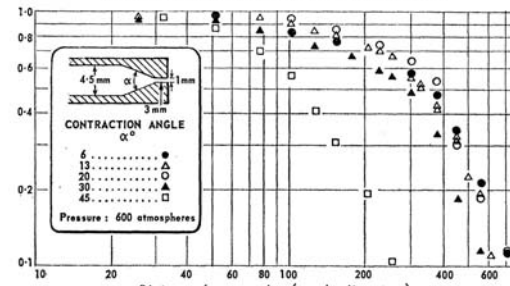

(c) Sharp corners

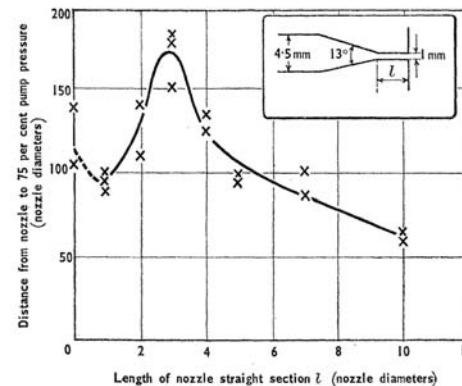

Leach & Walker:

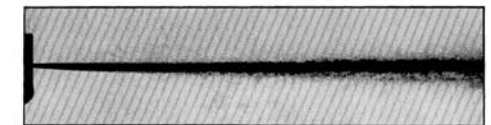

(d) Spark source; parallel transmitted light ($\frac{1}{2} \mu\text{s}$ exposure); pressure 130 atm.

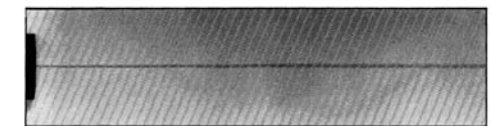

(e) X-ray source (5 min exposure); pressure 130 atm.

Conservation of Energy *vs.* $\mathbf{F} = d\mathbf{P}/dt$ at a Contraction? (Borda, 1766)

Incompressible fluid $\Rightarrow V_1 A_1 = V_2 A_2$.

$$A_2 \ll A_1 \Rightarrow V_1 \ll V_2.$$

Conservation of Energy \Rightarrow Bernoulli's Law:

$$P_1 + \frac{1}{2}\rho V_1^2 = P_2 + \frac{1}{2}\rho V_2^2.$$

$$V_1 \ll V_2 \Rightarrow V_2^2 \approx 2 \frac{P_1 - P_2}{\rho}.$$

Argument does not depend on the area.

$\mathbf{F} = d\mathbf{P}/dt$:

Mass flux = $\rho V A$.

Momentum flux = $\rho V^2 A$.

Net momentum flux = $\rho(V_2^2 A_2 - V_1^2 A_1)$
 $= \rho V_2 A_2 (V_2 - V_1) \approx \rho V_2^2 A_2.$

Force $\approx (P_1 - P_2) A_2$.

$$\mathbf{F} = \frac{d\mathbf{P}}{dt} \Rightarrow V_2^2 \approx \frac{P_1 - P_2}{\rho}.$$

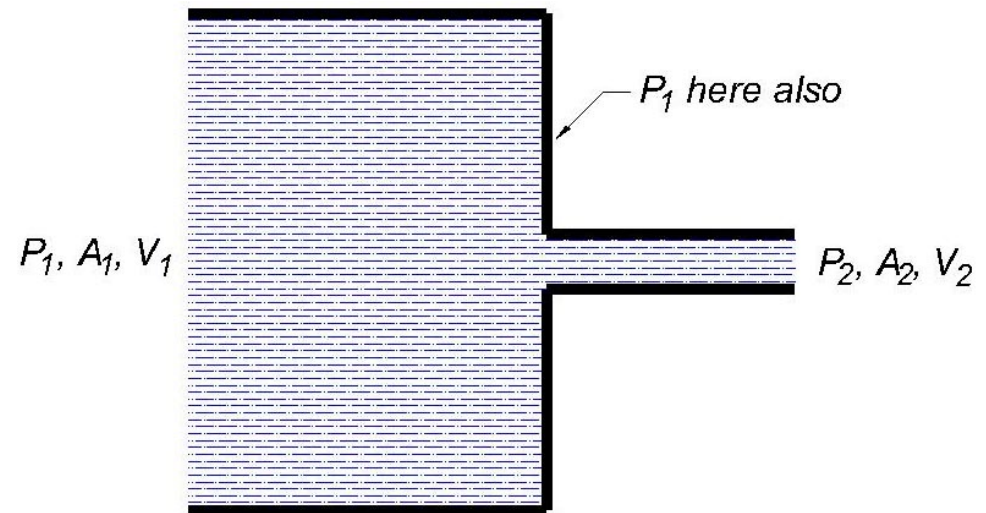

Consistency \Rightarrow dissipative loss of energy, OR jet pulls away from the wall and contracts.

Vena Contracta

Cavitation can be induced by a sharp-edged aperture.

A jet emerging from a small aperture in a reservoir contracts in area:

$$A_{\text{jet}} = \frac{\pi}{\pi + 2} A_{\text{aperture}} = 0.62 A_{\text{aperture}}$$

$$d_{\text{jet}} = 0.78 d_{\text{aperture}}$$

2-d potential flow (conservation of energy) \Rightarrow analytic form:

$$x = \frac{2d}{\pi + 2} (\tanh^{-1} \cos \theta - \cos \theta), \quad y = d - \frac{2d}{\pi + 2} (1 + \sin \theta),$$

$$\theta = \text{angle of streamline}, \quad -\frac{\pi}{2} < \theta < 0.$$

90% of contraction occurs for $x < 0.8d$.

Good agreement between theory and experiment.

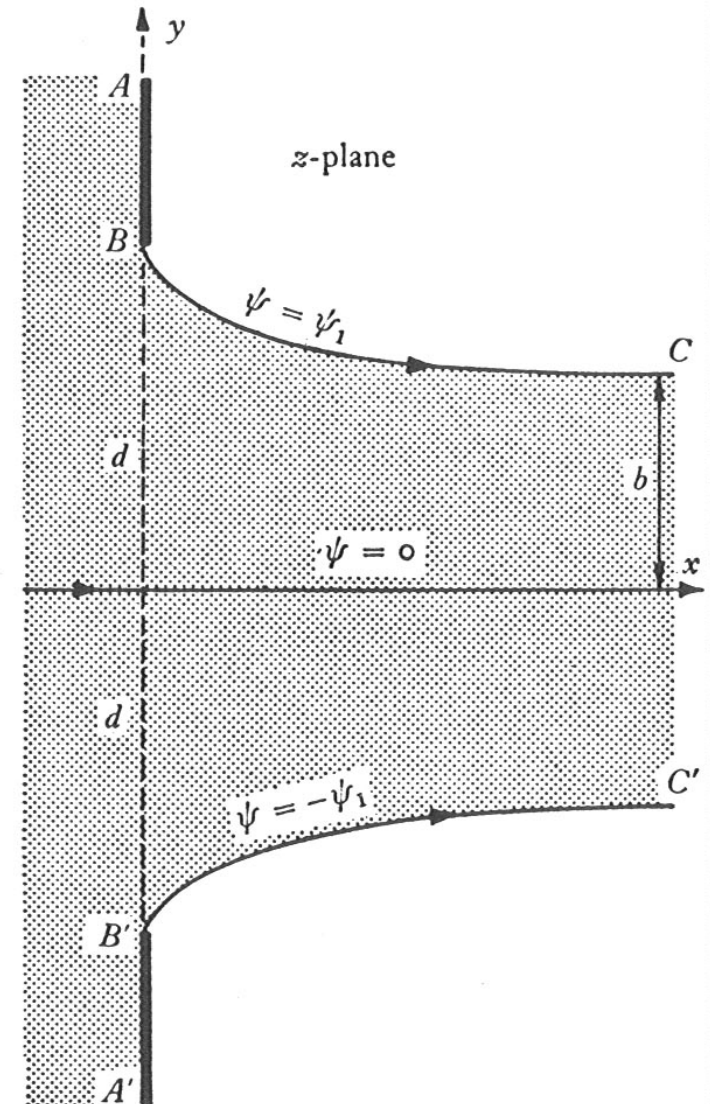

Magnetic Issues for Liquid Metal Jet Targets

Conducting materials that move through nonuniform magnetic field experience eddy-current effects, \Rightarrow Forces on entering or leaving a solenoid (but not at its center).

\Rightarrow Free jet of radius r cannot pass through a horizontal solenoid of diameter D unless

$$v > \frac{3\pi\sigma r^2 B_0^2}{32\rho D} \approx 6 \left[\frac{r}{1 \text{ cm}} \right]^2 \text{ m/s}, \quad \text{for Hg or Pb-Bi jet, } D = 20 \text{ cm, } B_0 = 20 \text{ T.}$$

50-Hz rep rate requires $v = 20$ m/s for new target each pulse, so no problem for baseline design with $r = 0.5$ cm. The associated eddy-current heating is negligible.

[Small droplets pass even more easily, and can fall vertically with no retardation.]

A liquid jet experiences a quadrupole shape distortion if tilted with respect to the solenoid axis. This is mitigated by the upstream iron plug that makes the field more uniform.

Magnetic damping of surface-tension waves (Rayleigh instability) observed in CERN-Grenoble tests (2002).

The beam-induced dispersal will be partially damped also (Samulyak).

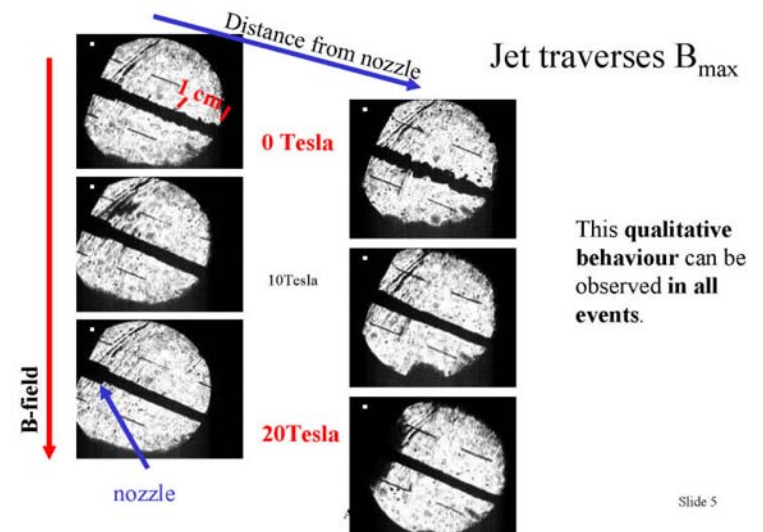

Slide 5

Exercises

9. If one pitches a penny into a large magnet, eddy currents are induced in the penny, and their interaction with the magnetic field results in a repulsive force, according to Lenz' law. Estimate the minimum velocity needed for a penny to enter a long, 1-T solenoid magnet whose diameter is 10 cm.

You may suppose that the penny moves so that its axis always coincides with that of the magnet, and that gravity may be ignored. The speed of the penny is low enough that the magnetic field caused by the eddy currents may be neglected compared to that of the solenoid. Equivalently, you may assume that the magnetic diffusion time is small.

See, prob. 1b of <http://puhep1.princeton.edu/~mcdonald/examples/ph501set5.pdf>

10. Extend the analysis of exercise 10 to the case where the penny (liquid metal jet) enters the magnet at angle θ to the field axis.

See, <http://www.hep.princeton.edu/~mcdonald/mumu/target/jet.pdf>

The Shape of a Mercury Jet under a Non-uniform Magnetic Field

S. Oshima *et al.*, JSME Int. J. 30, 437 (1987).

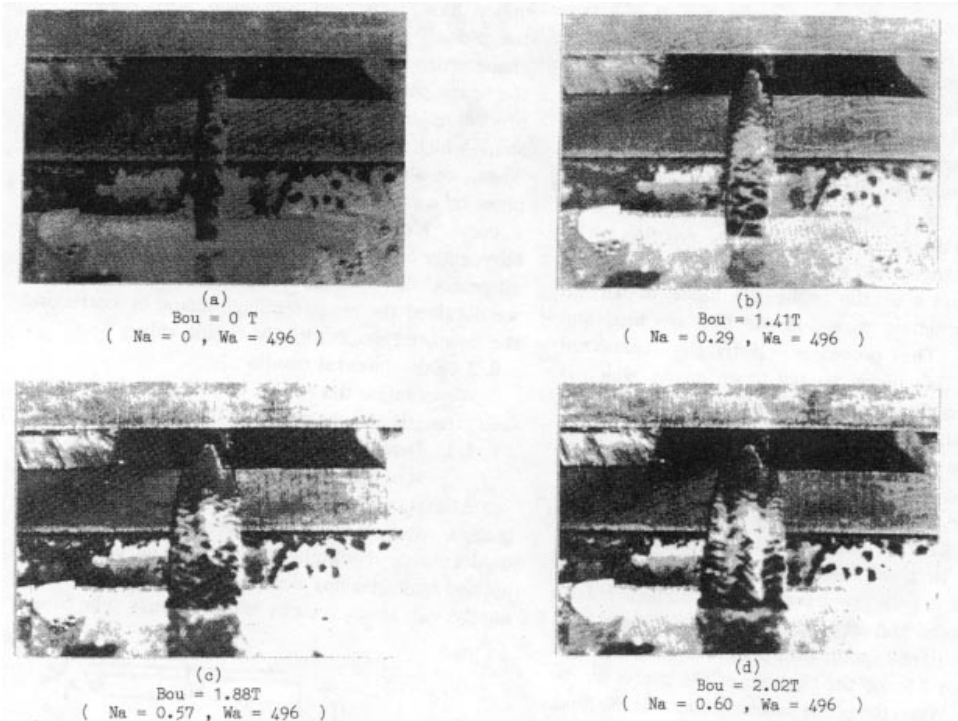

Fig. 9 Photographs of the jet for various applied magnetic field strengths

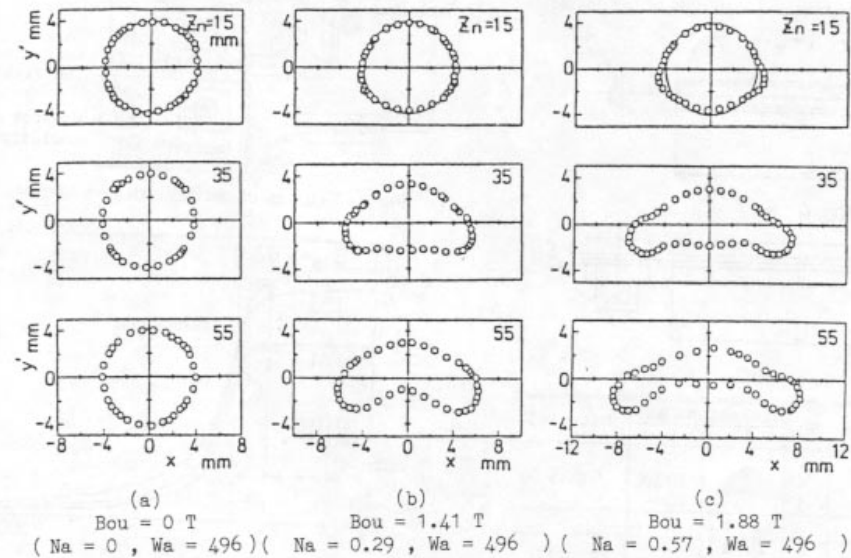
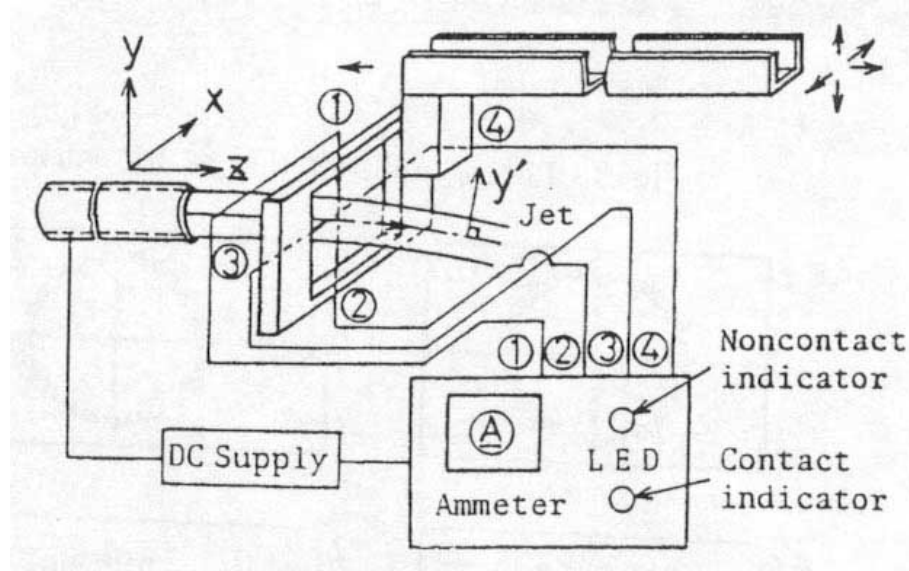
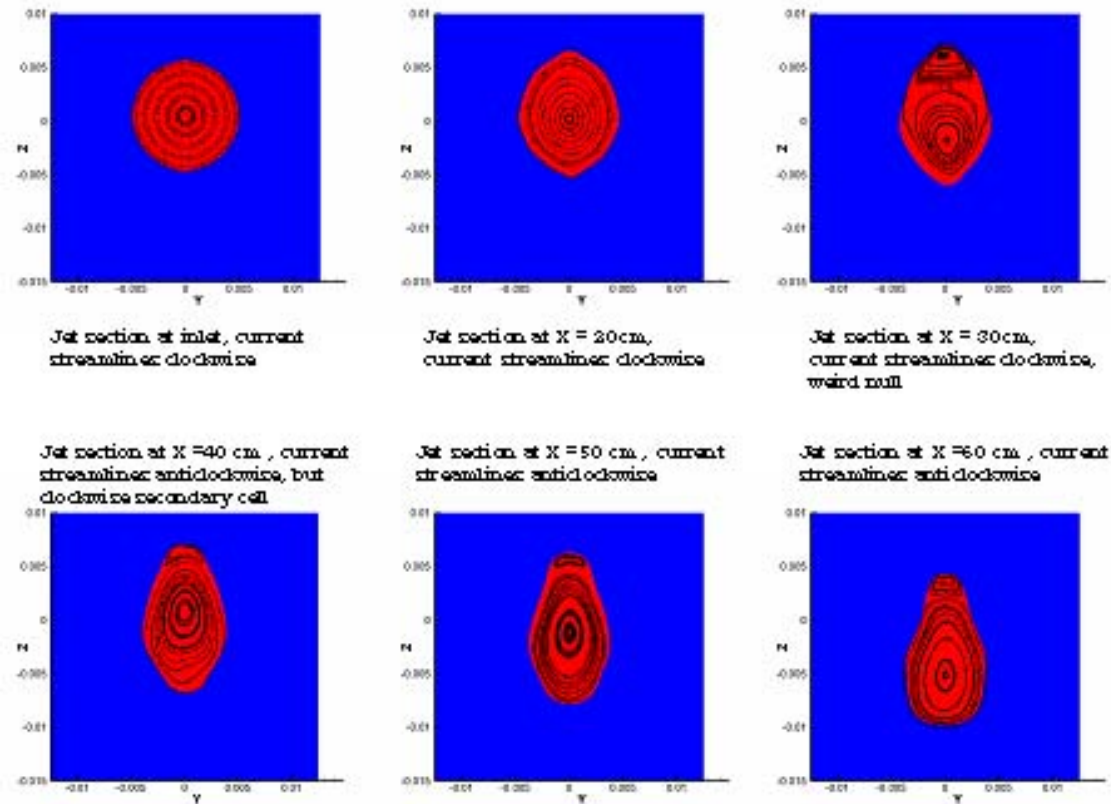
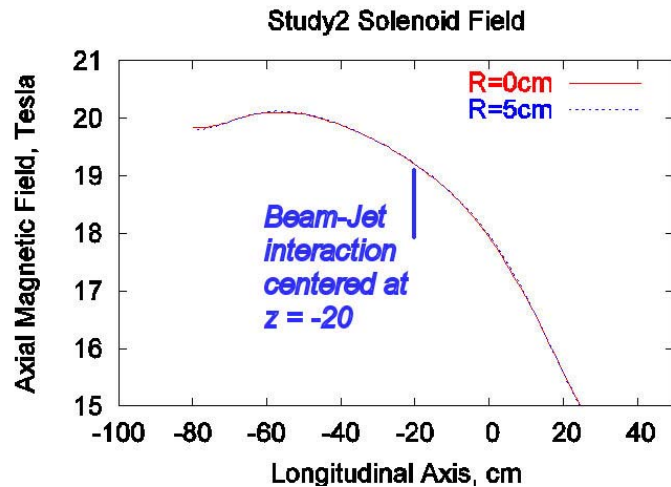

Fig. 10 Cross-sectional shape of the jet obtained by spot a electrode probe

Simulations of Shape Distortion

Incompressible code with free liquid surface confirms predictions of shape distortion of a liquid mercury jet that crosses magnetic field lines. (N. Morley, M. Narula; HIMAG).

Mitigate with good uniformity of magnetic field:



Beam-Induced Effects on a Liquid Jet

Beam energy deposition may disperse the jet.

FRONTIER simulation predicts breakup via filamentation on mm scale:

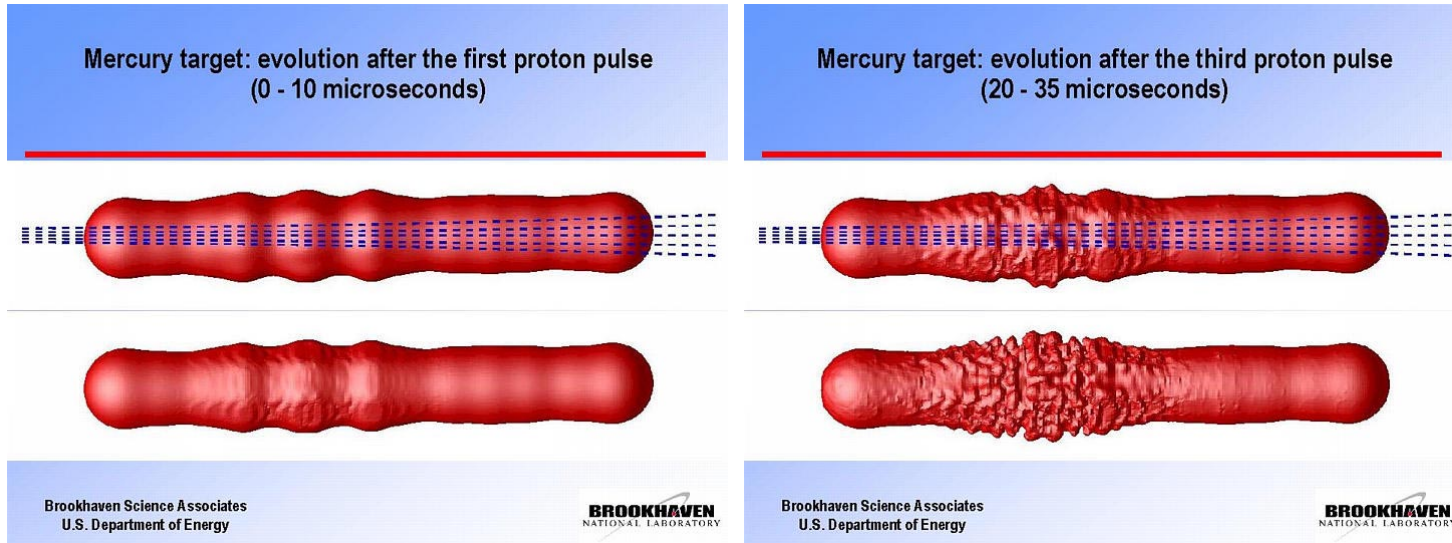

Laser-induced breakup of a water jet:
(J. Lettry, CERN)

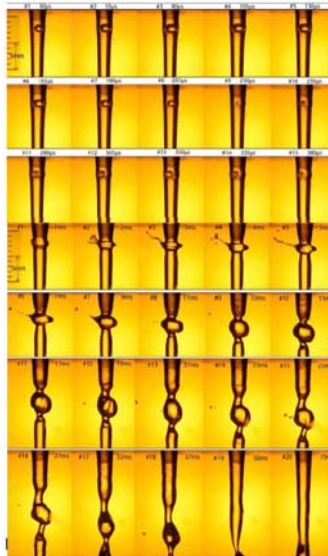

Water jet ripples generated by a 8 mJ Laser cavitation bubble



Beam-Induced Cavitation in Liquids Can Break Pipes

Hg in a pipe (BINP):

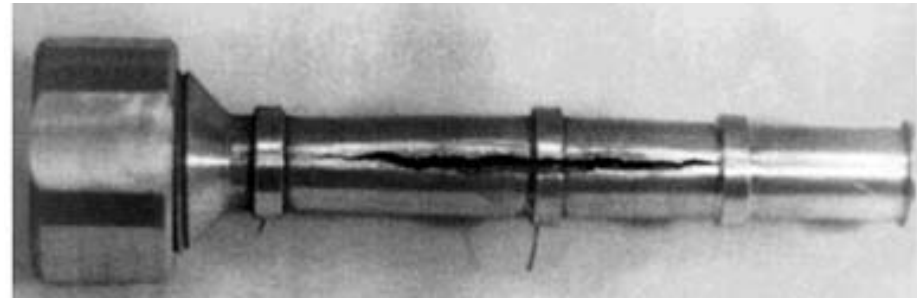

ISOLDE:



Cavitation pitting of SS wall surrounding Hg target after 100 pulses (SNS):

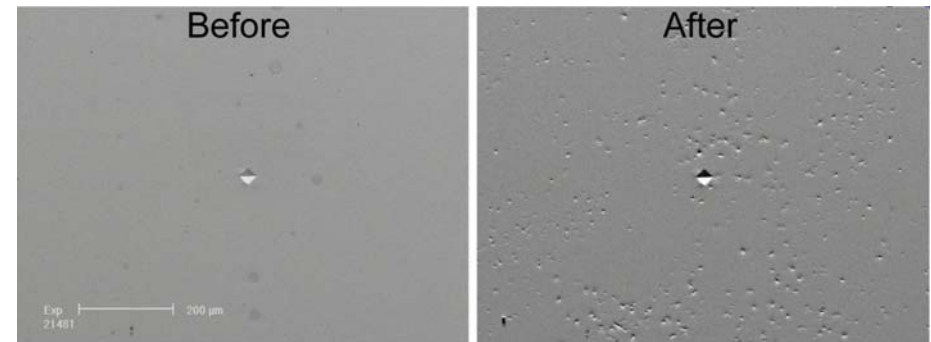

TL - High Power Target
Specimen # 29754
Equivalent SNS Power Level = 2.5

Water jacket of NuMI target developed a leak after ≈ 1 month.
Likely due to beam-induced cavitation.

⇒ Use free liquid jet if possible.

How Snapping Shrimp Snap: Through Cavitating Bubbles

M. Versluis, Science 289, 2114 (2000).

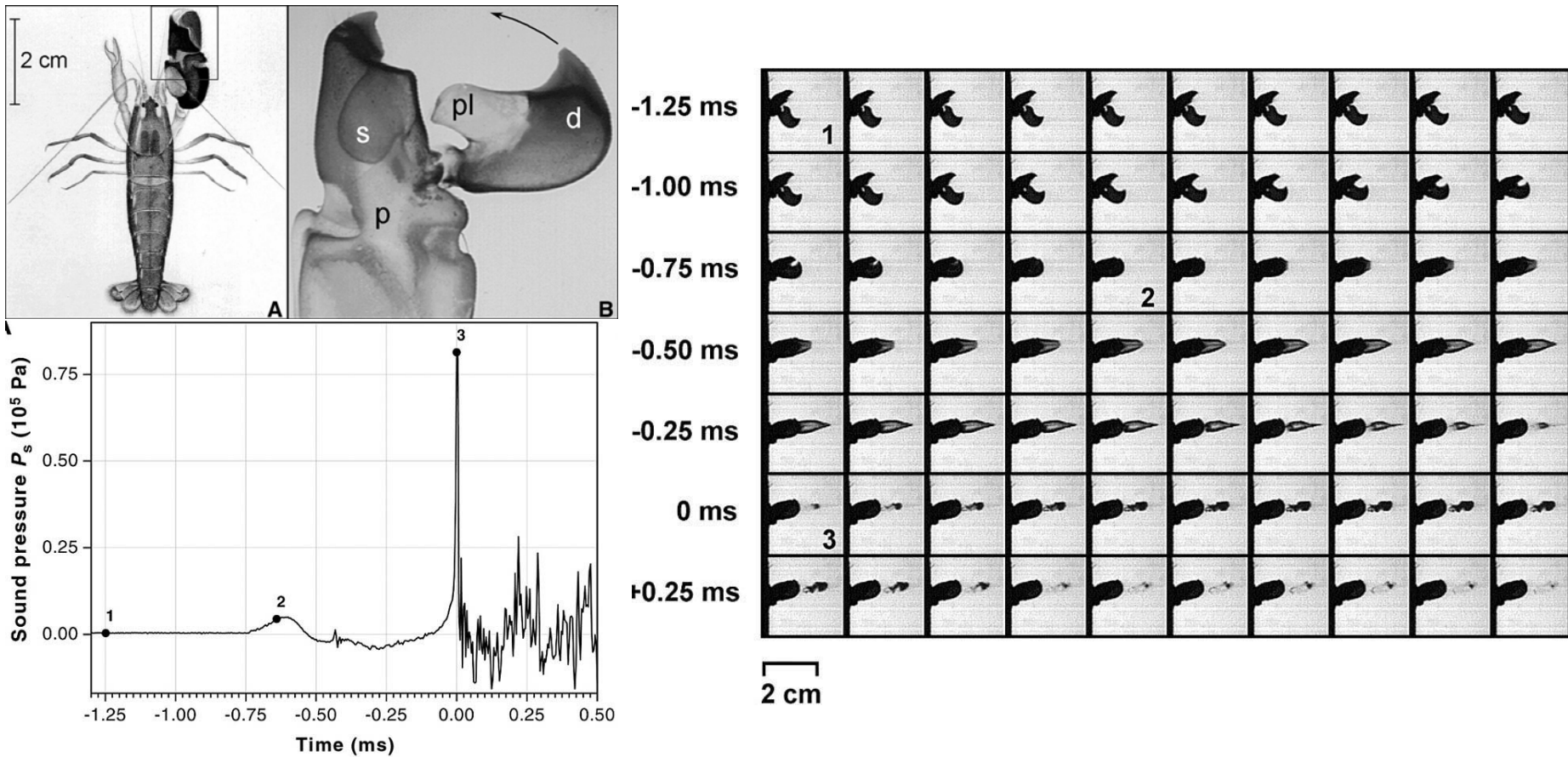

Exercises

11. Estimate the dispersal velocity of a liquid jet into which a proton beam deposits U J/g.

Model:
$$v_{\text{dispersal}} = \frac{\Delta r}{\Delta t} = \frac{r\alpha\Delta T}{r/v_{\text{sound}}} = \frac{\alpha U}{C} v_{\text{sound}} \approx 50 \text{ m/s for } U \approx 100 \text{ J/g.}$$

12. In the phenomenon of single-bubble sonoluminescence, a water bubble of initial radius of $40 \mu\text{m}$ is observed to emit light when its radius collapses to about $0.5 \mu\text{m}$ under one atmosphere pressure. Approximately 6×10^6 photons are emitted in the energy range 1-6 eV, with a bremsstrahlung-like spectrum of the form $dN \propto dE/E$ where E is the photon energy. (Water is opaque to photons above about 6 eV.)

In this problem the bubble can assumed to contain vacuum.

- Suppose that all the kinetic energy of the collapsing bubble is converted to photons with the spectrum $dN \propto dE/E$. What would be the maximum photon energy emitted?
- At what radius does the velocity of the inner surface of the bubble reach the speed of sound in water, 1,500 m/s?

See, <http://puhep1.princeton.edu/~mcdonald/examples/sonobubble.pdf>

13. When an electron (or positronium atom) is injected into liquid helium with nearly zero energy, a bubble quickly forms around it. This phenomenon (which also occurs in liquid hydrogen and liquid neon) lowers the mobility of the electron to a value similar to that for a positive ion.

Estimate the radius of the bubble at zero pressure and temperature.

If the liquid is held in a state of negative pressure, the bubble will expand beyond the radius at zero pressure. Estimate the negative pressure such that a bubble once formed will grow without limit.

Hint: Consider the pressure associated with the zero-point energy of an electron in a bubble.

See, <http://puhep1.princeton.edu/~mcdonald/examples/hebubble.pdf>

Passive Mercury Target Tests

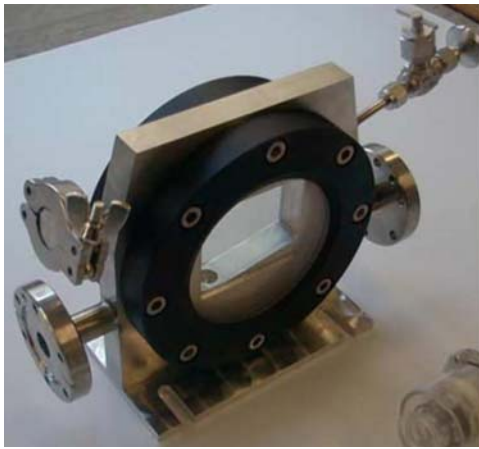

Exposures of 25 μ s at
 $t = 0, 0.5, 1.6, 3.4$ msec,
 $\Rightarrow v_{\text{splash}} \approx 20 - 40$ m/s:

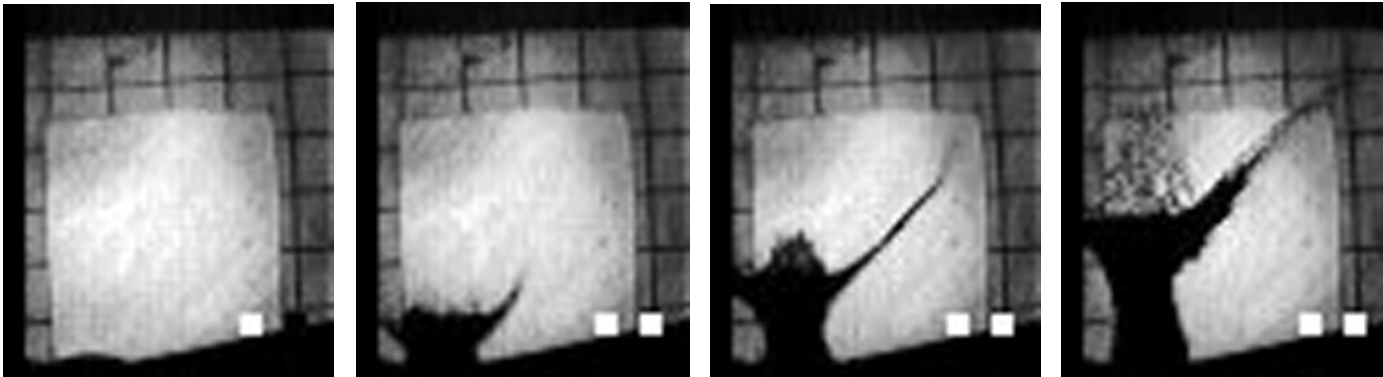

Two pulses of ≈ 250 ns give larger dispersal velocity only if separated by $< 3 \mu$ s.

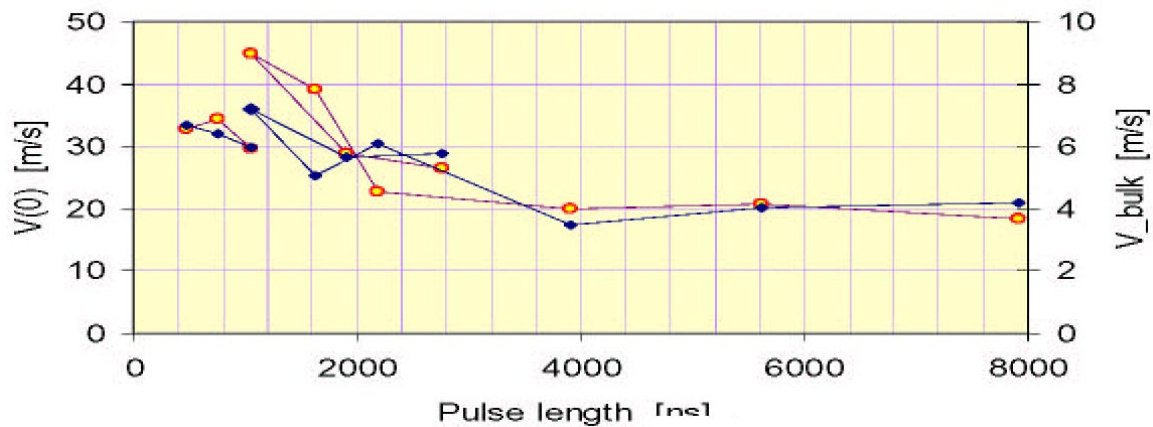

Studies of Proton Beam + Mercury Jet

1-cm-diameter Hg jet in $2e12$ protons at $t = 0, 0.75, 2, 7, 18$ ms.

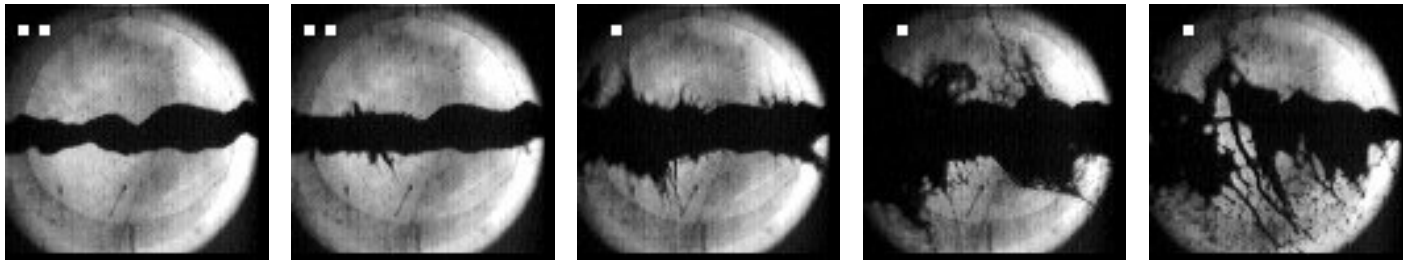
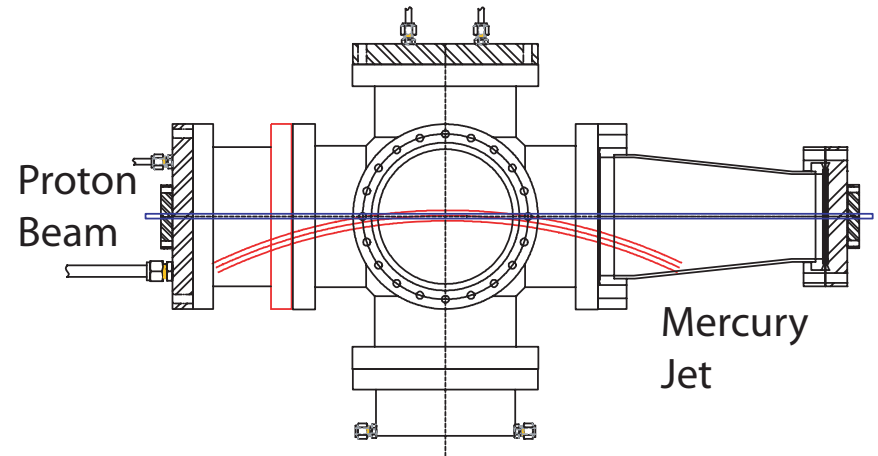

Model:
$$v_{\text{dispersal}} = \frac{\Delta r}{\Delta t} = \frac{r\alpha\Delta T}{r/v_{\text{sound}}} = \frac{\alpha U}{C} v_{\text{sound}} \approx 50 \text{ m/s for } U \approx 100 \text{ J/g.}$$

Data: $v_{\text{dispersal}} \approx 10 \text{ m/s for } U \approx 25 \text{ J/g.}$

$v_{\text{dispersal}}$ appears to scale with proton intensity.

The dispersal is not destructive.

Filaments appear only $\approx 40 \mu\text{s}$ after beam,
 \Rightarrow After several bounces of waves, OR v_{sound} very low.

Computational Magnetohydrodynamics (R. Samulyak)

Use an equation of state that supports negative pressures, but gives way to cavitation.

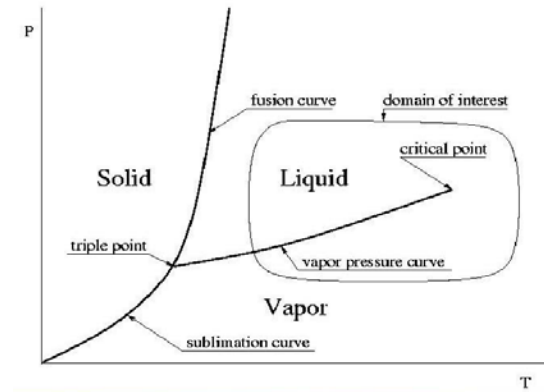

Critical point : $T_c = 1750\text{K}$, $P_c = 172\text{MPa}$, $V_c = 43\text{ cm}^3\text{ mol}^{-1}$

Thimble splash at 0.24, 0.48, 0.61, 1.01 μs

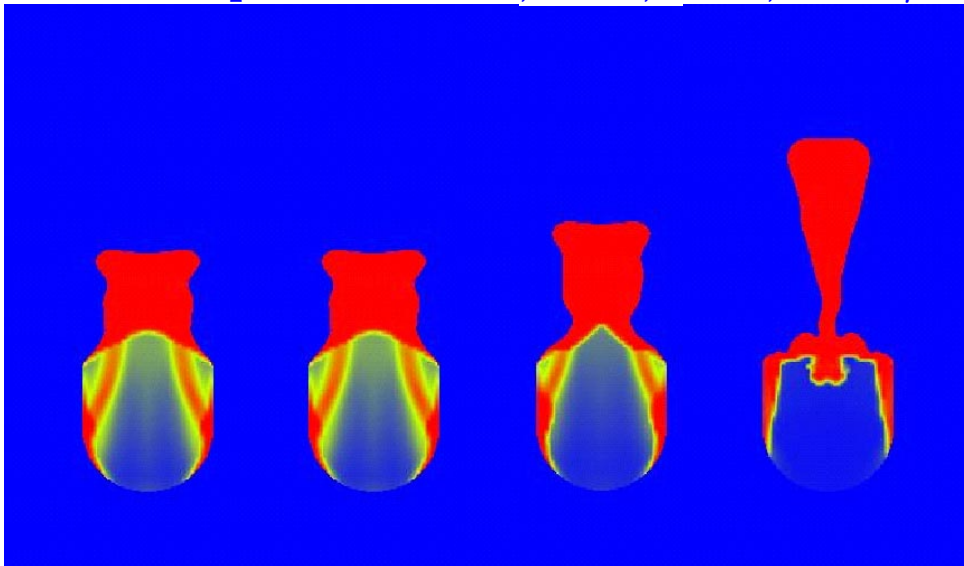

Magnetic damping of beam-induced filamentation:

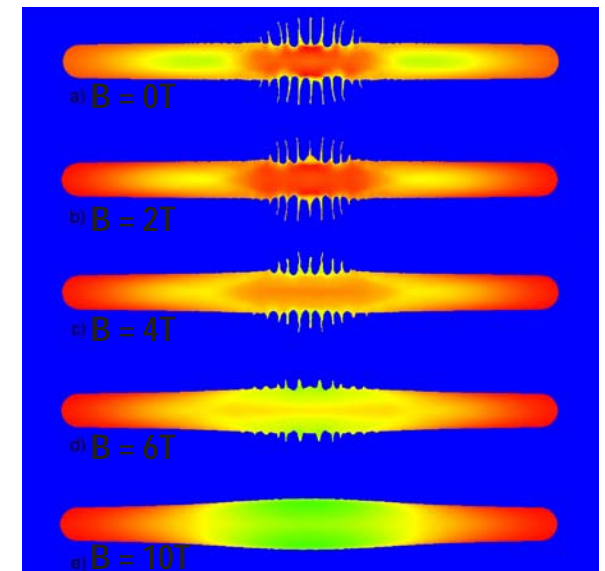

What Have We Learned?

- Solid targets are viable in pulsed proton beams of up to 1-2 MW.
- Engineered materials with low coefficients of thermal expansion are desirable, but require further qualification for use at high radiation dose.
- A mercury jet appears to behave well in a proton beam at zero magnetic field, and in a high magnetic field without proton beam.

Issues for Further Targetry R&D

- Continue numerical simulations of MHD + beam-induced effects.
- For solid targets, study radiation damage – and issues of heat removal from solid metal targets (carbon/carbon, Toyota Ti alloy, bands, chains, *etc.*).
- Proof-of-Principle test of an intense proton beam with a mercury jet inside a high-field magnet (CERN MERIT experiment).
 1. MHD effects in a prototype target configuration.
 2. Magnetic damping of mercury-jet dispersal.
 3. Beam-induced damage to jet nozzle – in the magnetic field.