

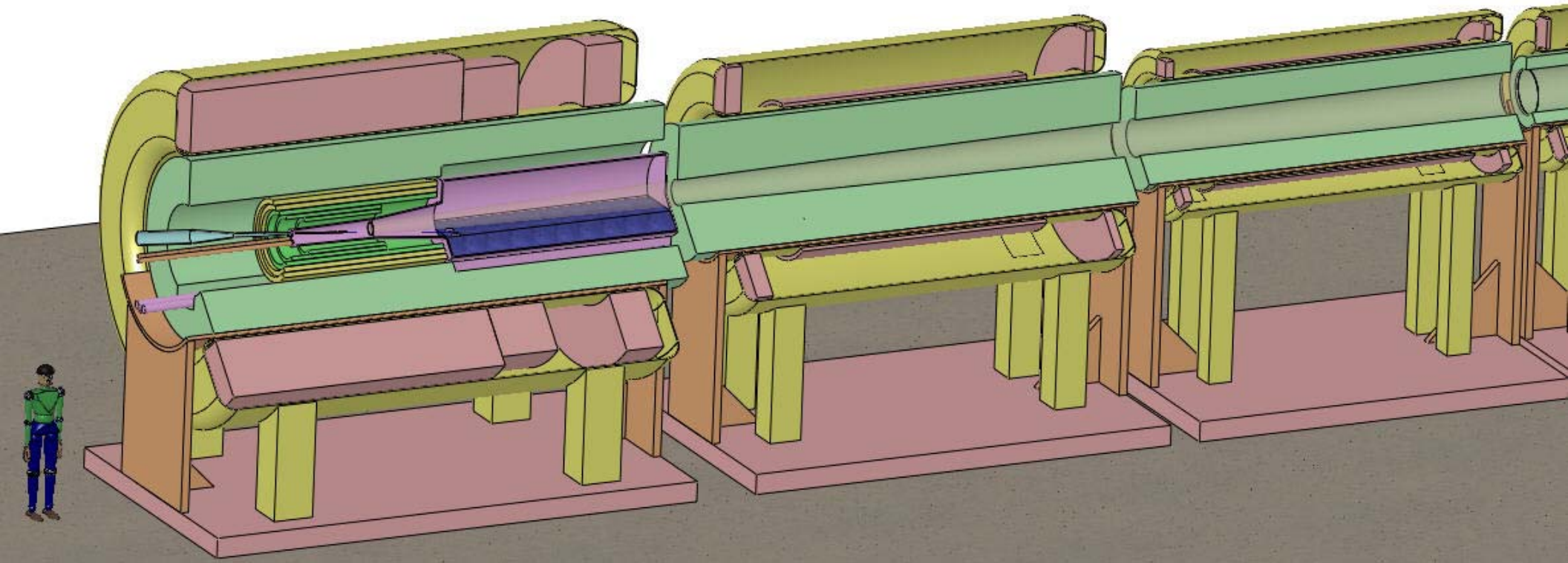

# Target and Absorbers for a Muon Collider/Neutrino Factory



K.T. McDonald

*Princeton U.*

(August 30, 2012)

Muon Accelerator Program DoE Review

*Fermilab (August 29-31, 2012)*



# Mission



## Target:

- Maximum production of  $\mu^\pm$  of energies  $\sim 100\text{-}400$  MeV from a 4-MW proton beam ( $E \sim 8$  GeV).
- Both signs needed simultaneously at a Muon Collider.

## Absorbers:

- Absorb the 4-MW beam power inside the target system.
- Absorb muon energy as a step in the process of ionization cooling.

## Overview

## Target:

- Free liquid-metal-jet target inside a high-field superconducting solenoid magnet
- Backup (not actively considered): solid target in toroidal horn; 2 needed for Muon Collider.

## Absorbers:

- Absorb primary proton beam in liquid-metal pool.
- Absorb secondary particles in He-gas-cooled tungsten beads - inside solenoid magnets.
- Low-Z solid/liquid muon absorbers under study in MICE (D. Kaplan)
- High-pressure  $\text{H}_2$ -gas absorbers under study by Muons Inc (H. Kirk).



# The Target System of a Muon-Collider or Neutrino Factory

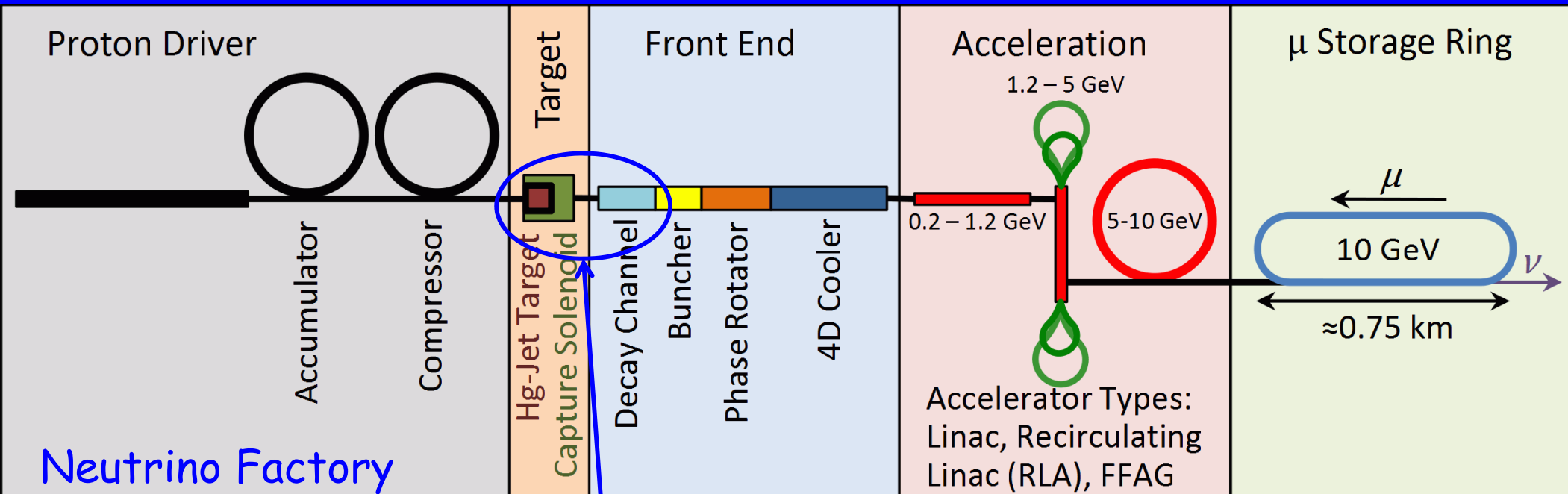

In the IDS-NF costing scenario, the Target System includes the production target and the magnetized pion-decay channel.

This system is about 50 m long.

A very preliminary cost estimate now exists (slide 5).

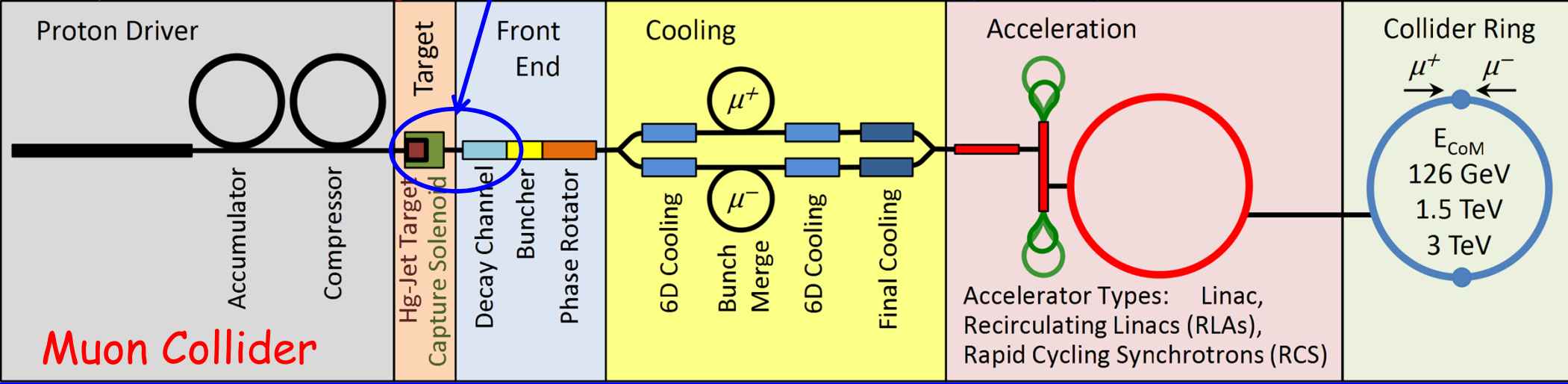



# Target and Capture Topology: Solenoid

Desire  $\approx 10^{14}$   $\mu/s$  from  $\approx 10^{15}$  p/s ( $\approx 4$  MW proton beam)

R.B. Palmer (BNL, 1994) proposed a 20-T solenoidal capture system.

Low-energy  $\pi$ 's collected from side of long, thin cylindrical target.

Solenoid coils can be some distance from proton beam.

$\Rightarrow \geq 10$ -year life against radiation damage at 4 MW.

Liquid mercury jet target replaced every pulse.

Proton beam readily tilted with respect to magnetic axis.

$\Rightarrow$  Beam dump (mercury pool) out of the way of secondary  $\pi$ 's and  $\mu$ 's.

5-T copper magnet insert; 10-T  $Nb_3Sn$  coil + 5-T NbTi outsert.

Desirable to eliminate the copper magnet (or replace by a 20-T HTS insert).

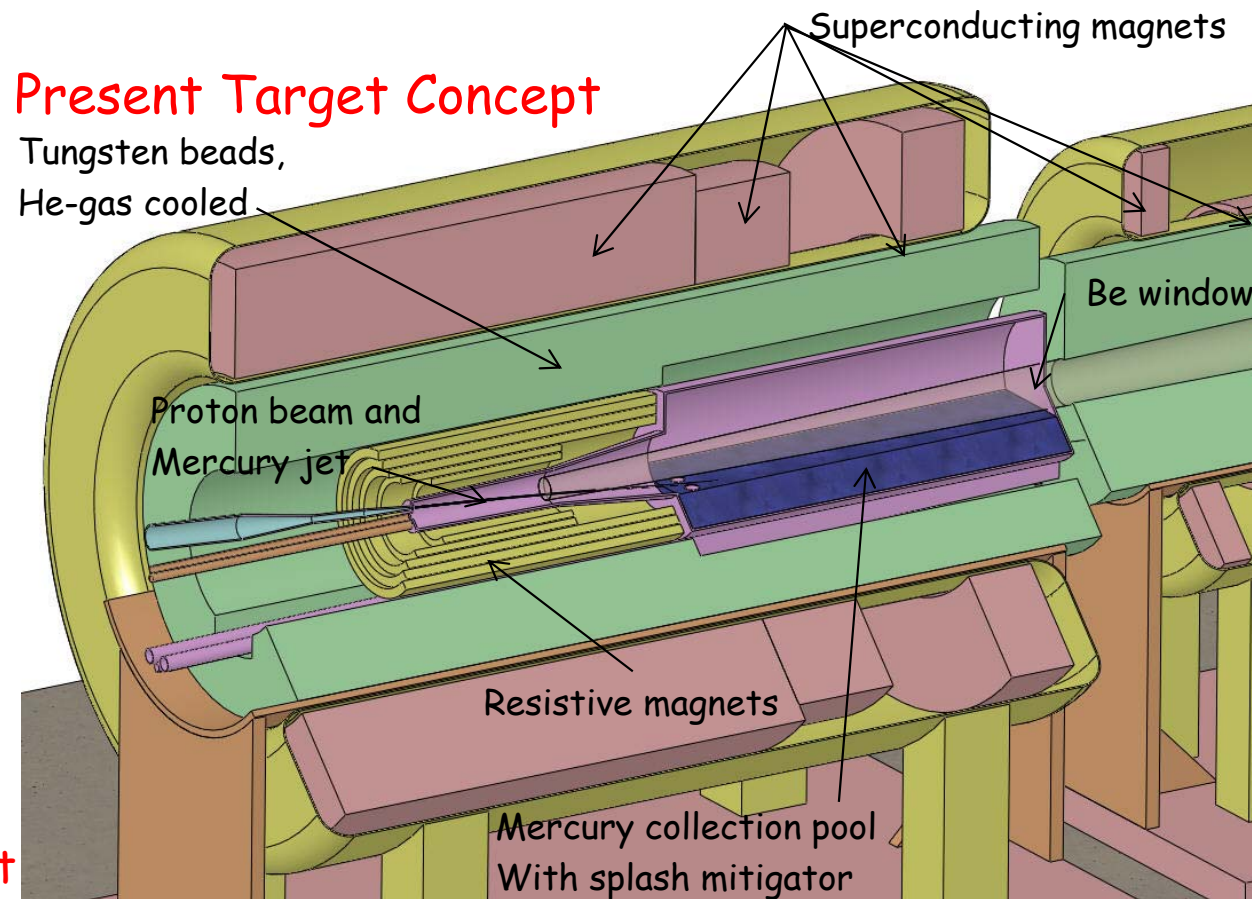

## Present Target Concept

Shielding of the superconducting magnets from radiation is a major issue.

Magnet stored energy  $\sim 3$  GJ!



# From A. Kurup's IDS-NF Costing Talk

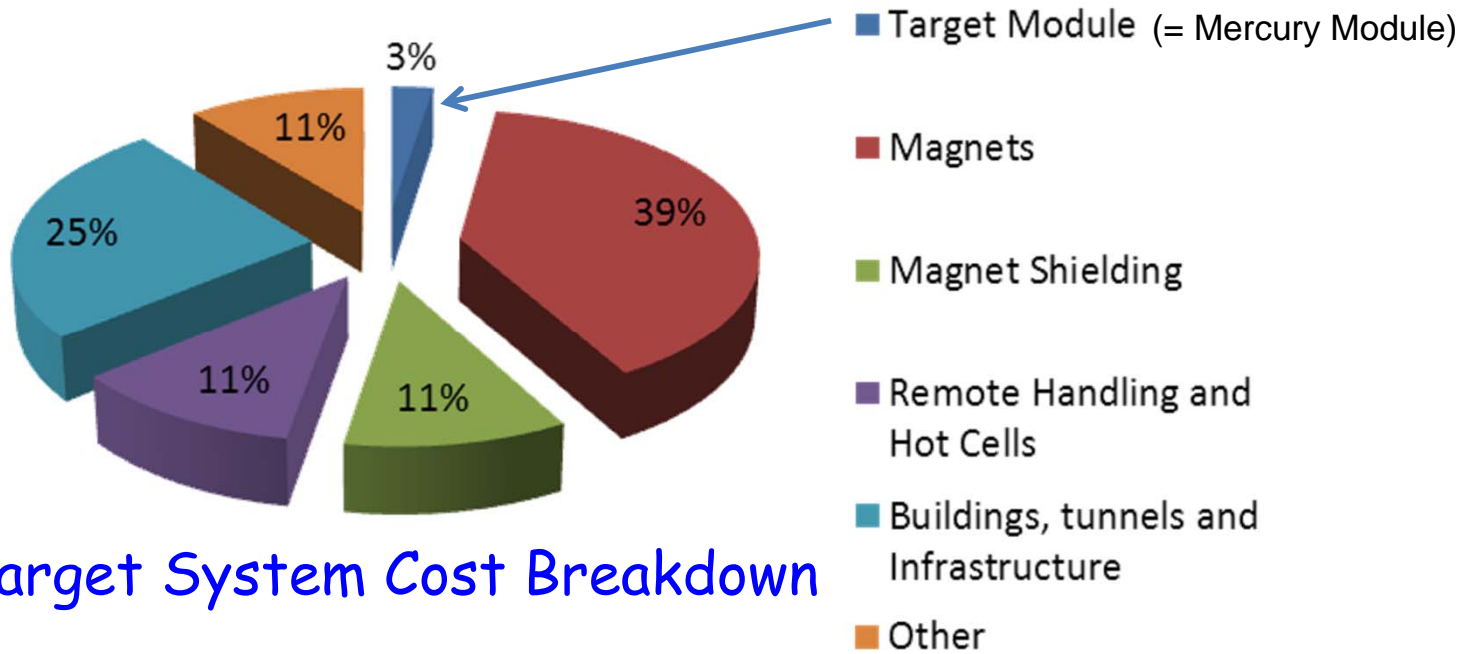

[See Backup Slides for supporting details.]

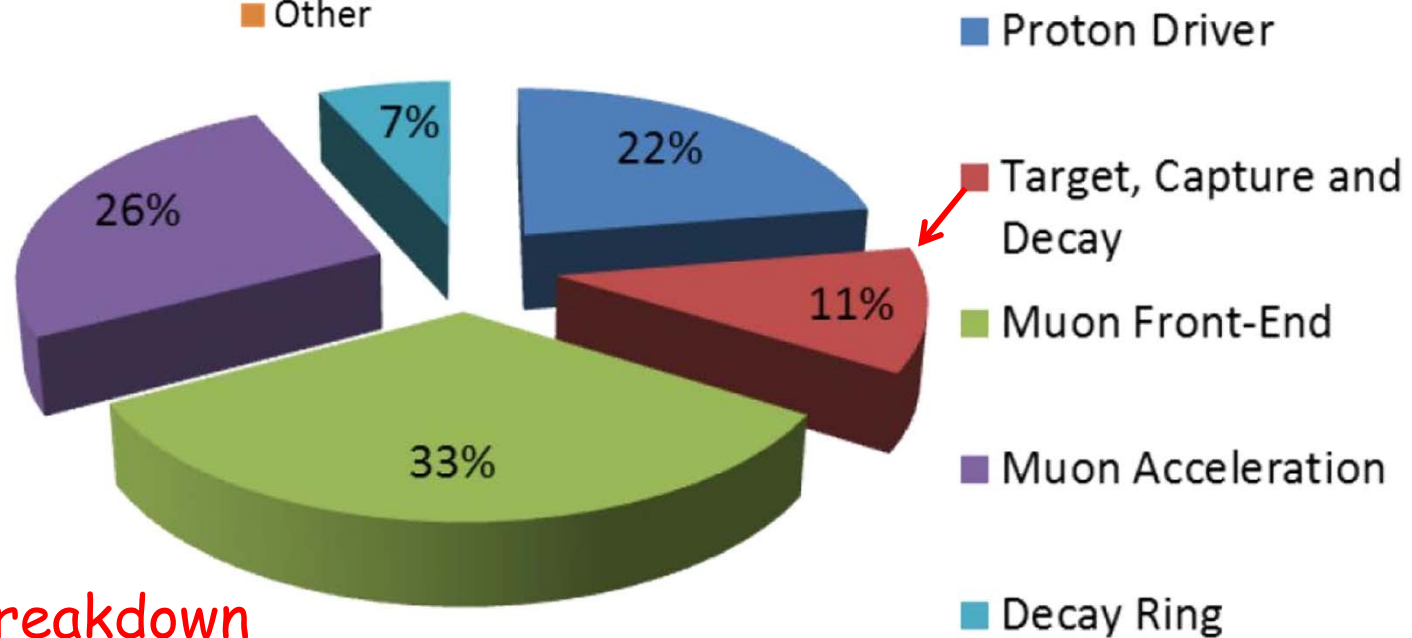

## Neutrino Factory Cost Breakdown



# Targetry Activities

1. Simulation of beam-jet interaction in a magnetic field (R. Samulyak, T. Guo).
2. Simulation of turbulent flow inside, and out of, the nozzle (F. Ladiende, Y. Zhan).
3. Simulation of particle production vs. beam & target parameters (X. Ding).
4. Simulation of the effect of the magnetic configuration on particle production (H. Sayed).
5. Simulation of secondary-energy deposition in the target system (N. Souchlas).
6. Design of the magnets and shielding for the target system (R.J. Weggel).
7. Design of the mercury-handling system (V.B. Graves).
8. Coordination of the above, and interface with other MC/NF Systems (J.S. Berg, H.G. Kirk, K.T. McDonald).

The above activities are projected to continue well beyond FY15.

Past activities included a proof-of-principle demonstration of a free mercury jet in a 15-T magnetic field in an intense proton beam (CERN MERIT experiment).



# MERIT Experiment Summary



The MERIT experiment established proof-of-principle of a free mercury jet target in a strong magnetic field, with proton bunches of intensity equivalent to a 4 MW beam.

- The magnetic field stabilizes the liquid metal jet and reduces disruption by the beam.
- The length of disruption is less than the length of the beam-target interaction,  
⇒ Feasible to have a new target every beam pulse with a modest velocity jet.
- Velocity of droplets ejected by the beam is low enough to avoid materials damage.
- The threshold for disruption is a few  $\times 10^{12}$  protons, permitting disruption-free operation at high power if can use a high-rep-rate beam.
- Even with disruption, the target remains fully useful for secondary particle production for  $\approx 300 \mu\text{s}$ , permitting use of short bunch trains at high power.
- No apparent damage to stainless-steel wall only 1 cm from interaction region.

[See Backup Slides for additional details.]



# Simulation of Beam-Jet Interaction in a Magnetic Field

(R. Samulyak, T. Guo, *SUNY Stony Brook*)



Frontier simulation of high-speed-jet cavitation and breakup:



Smoothed-Particle-Hydrodynamics  
simulation of MERIT beam-jet interaction:

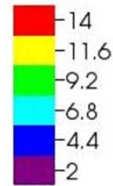
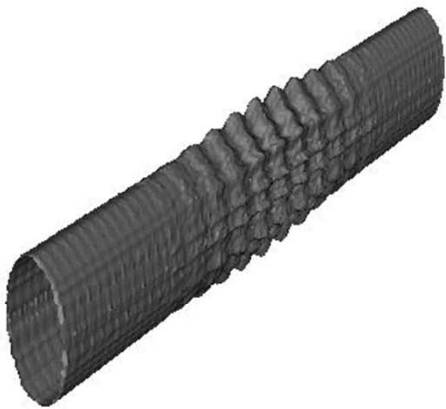

Simulation of mercury thimble experiments  
(2001) using the Lagrangian particle code:

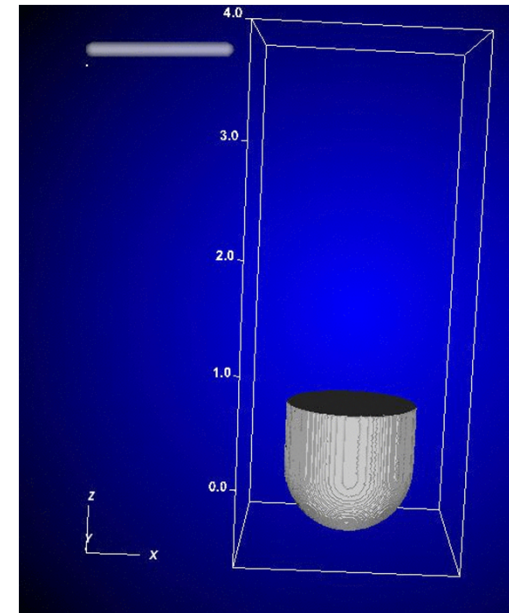





# Simulation of Turbulent Flow in the Nozzle

(F. Ladiende, Y. Zhan, *SUNY Stony Brook*)



Issue in MERIT: Free jet took on elliptical cross section, major axis vertical.

FLUENT simulations indicate that if no perturbations inside the pipe, the flow out of the nozzle would be nearly axisymmetric.

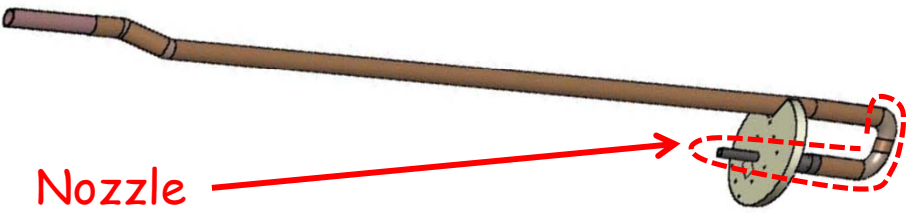
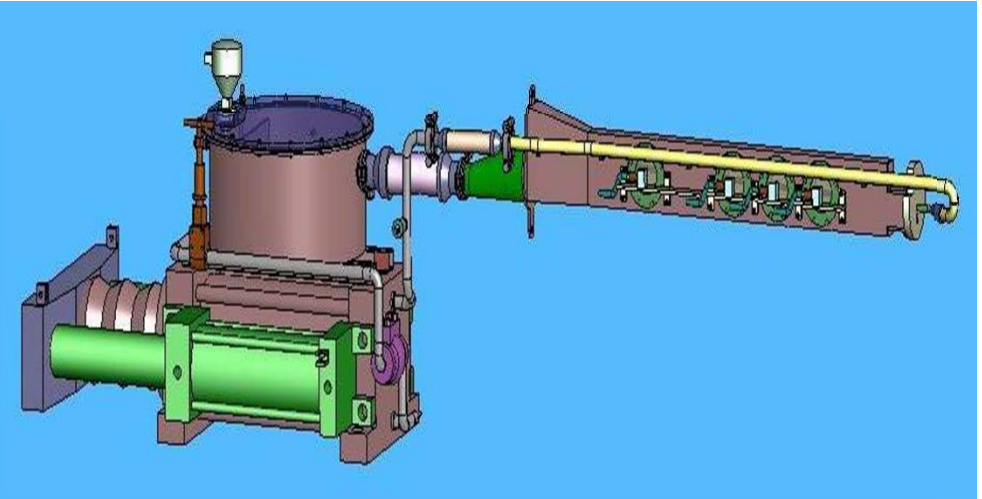

Nozzle

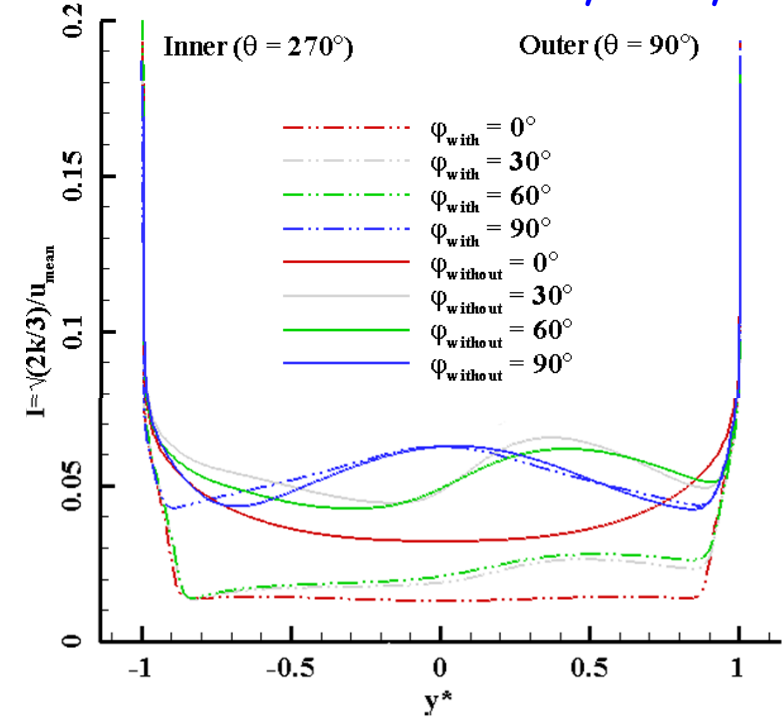
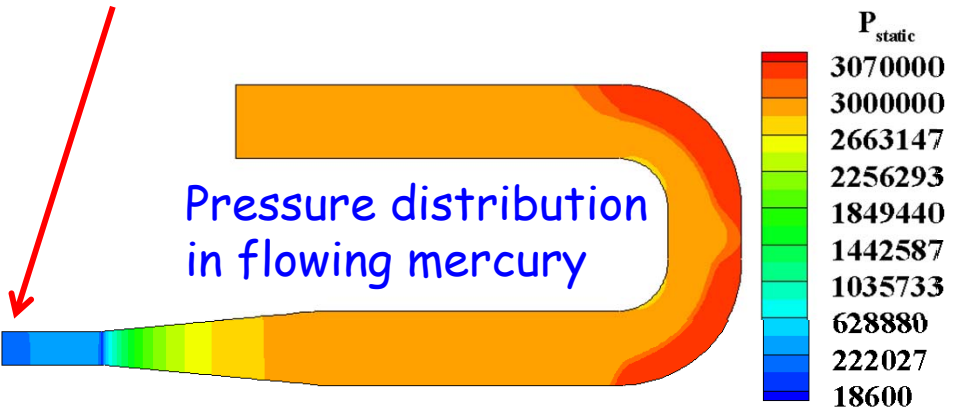

The last weld of the titanium nozzle had an asymmetric weld bead. Simulation underway.

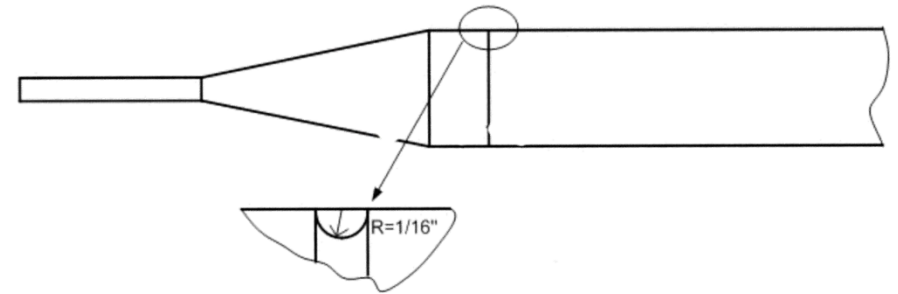



# Simulation of Particle Production vs. Beam & Target Parameters

(X. Ding, UCLA)



Vary: beam energy, beam radius, beam angle, target radius, target angle, target material (MARS15 simulations)

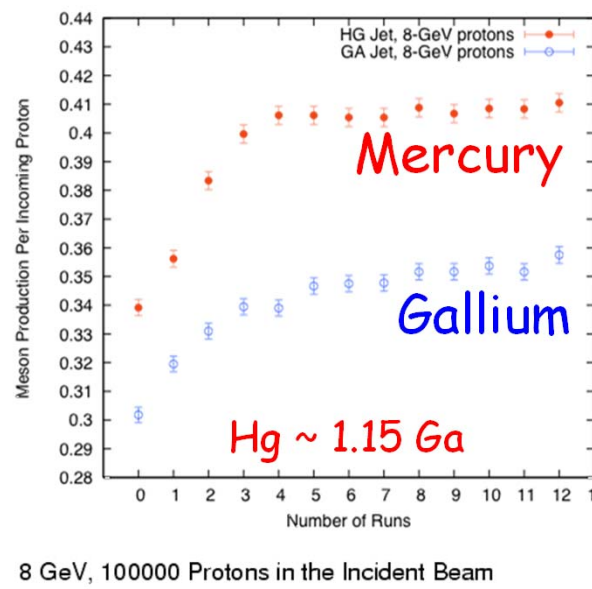
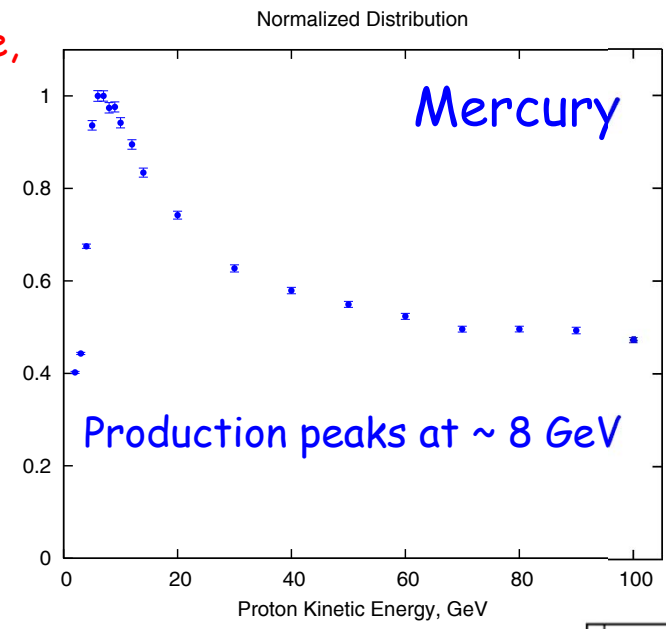
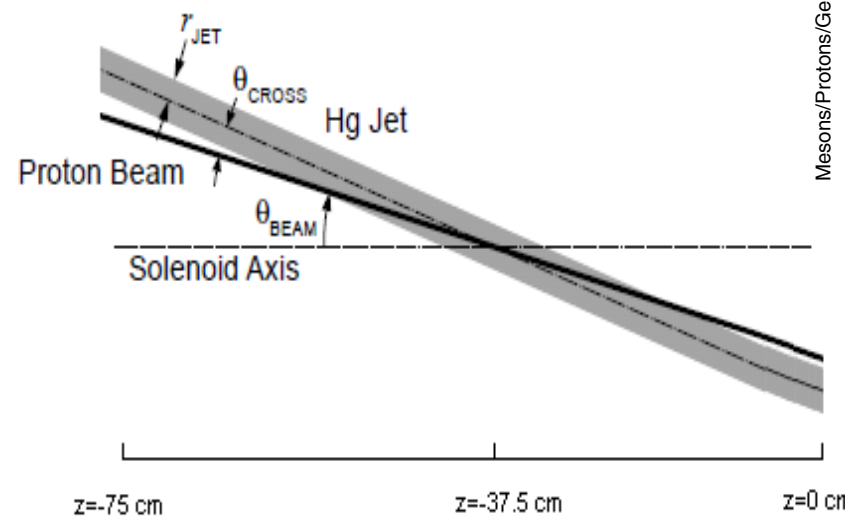

Consider option of multiple beams converging on the target from various azimuthal directions.

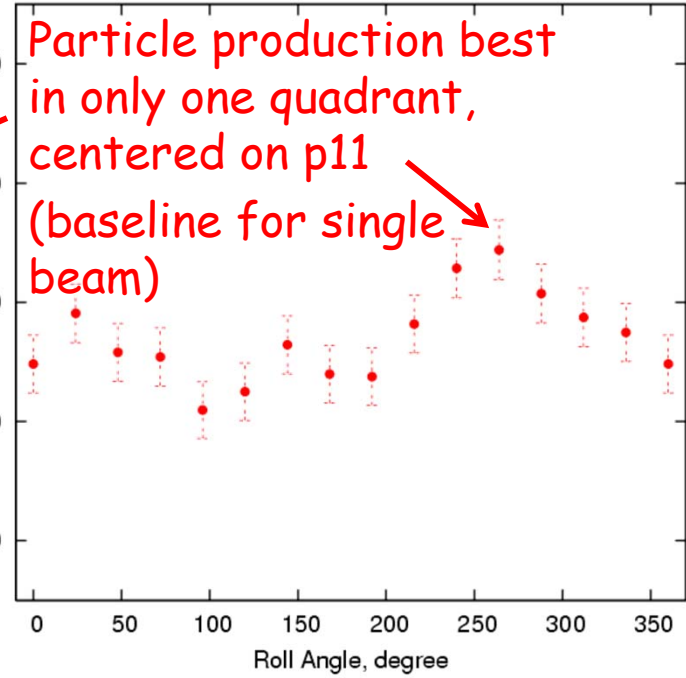
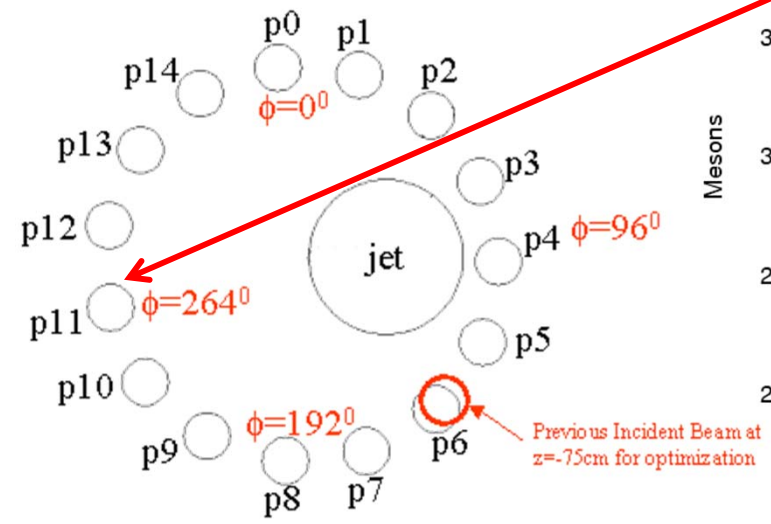



# Effect of the Magnetic Configuration on Particle Production

(H. Sayed, BNL)



The magnetic field of the target system varies from  $B_i$  at the target to  $B_f$  at the front end, over distance  $z_{end}$ .

Vary  $B_i$ ,  $B_f$  and  $z_{end}$ .

Results: Better production if  $B_i$ ,  $B_f$  and  $z_{end}$  are larger.

Present baseline:

$B_i = 20$  T,  $B_f = 1.5$  T,  $z_{end} = 1500$  cm.

Could reduce  $B_i$  from 20 to 15 T if compensate with larger  $B_f$  and  $z_{end}$ .

[Reduce cost, and simplify the mercury target module.]

Issue: Can the Phase Rotator accept the increased muon yield?  
 Addition yield is for muons with large R, where acceptance of the phase rotator/linac is low.

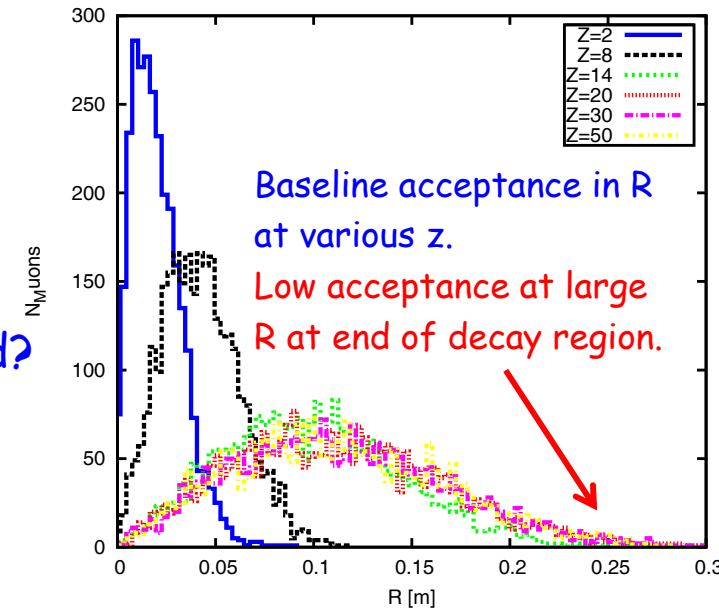
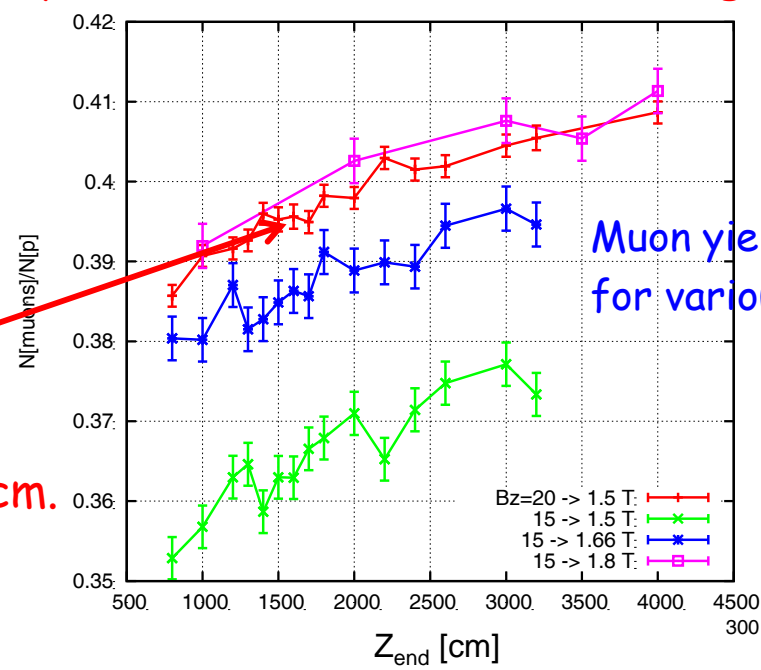



# Secondary-Energy Deposition in the Target System

(N. Souchlas, *PBL* + J.Back, *Warwick*)



Practical lifetime of superconducting coils (insulation) against radiation damage is  $\sim 10 \text{ MGray} = 10^4 \text{ J/g}$ .  
 For a lifetime of 10 "years" of  $10^7 \text{ s}$  each, the peak rate of energy deposition would be  $10^4 \text{ J/g} / 10^8 \text{ s} = 10^{-4} \text{ W/g} = 0.1 \text{ mW/g}$  (= 1 MGray/year of  $10^7 \text{ s}$ ).

Use *MARS15* (Souchlas) [and *Fluka* (Back)] to simulate energy deposition.

⇒ With shielding, most energy deposition in the SC magnets is due to 1-100 MeV neutrons.

⇒ Dense shield most effective. We now consider He-gas-cooled W beads.

⇒ Present baseline is  $R_{\text{outer,shield}} = R_{\text{inner,magnet}} = 120 \text{ cm}$ .

~ 500 kW of power (mostly scattered protons) leaves target system and enters the front end.

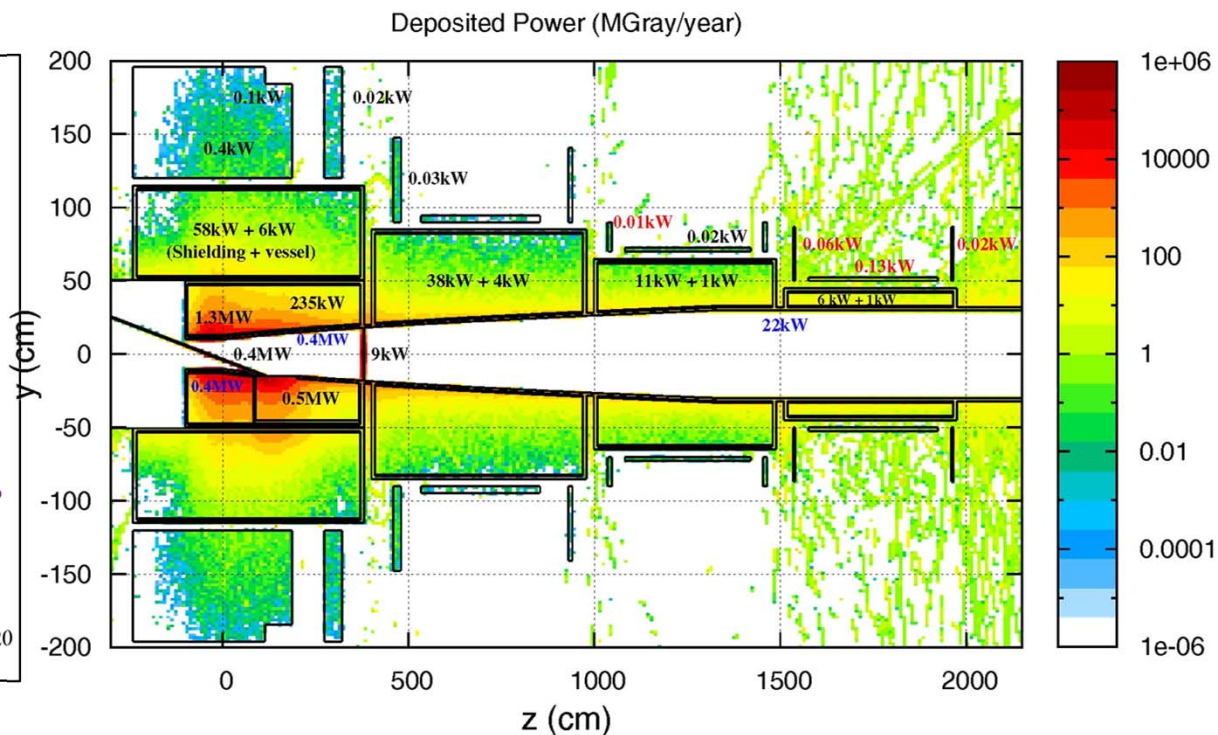
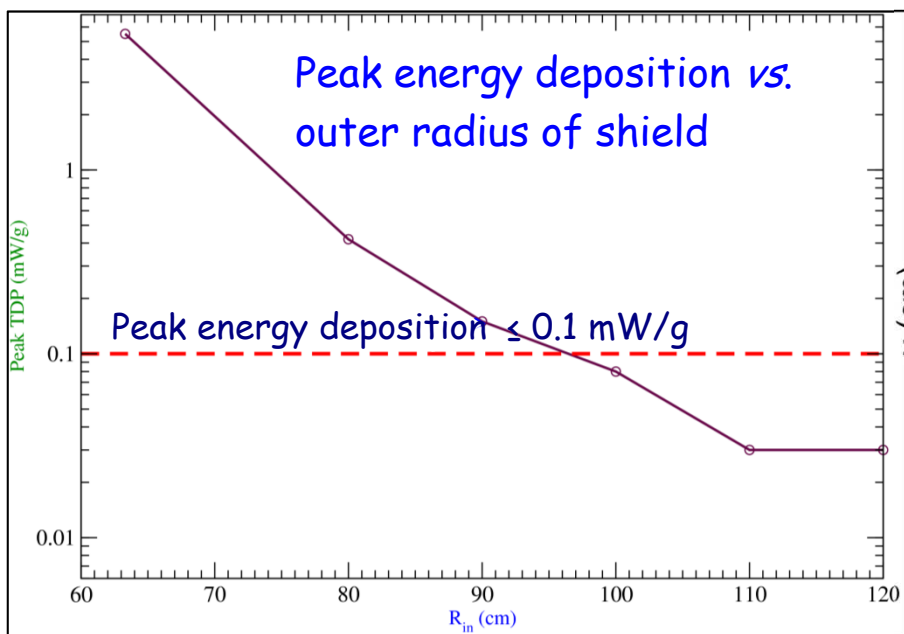



# Design of the Magnets and Shielding for the Target System

(R.J. Weggel, PBL)



Evolution of coil design to permit gaps for services to the internal He-gas-cooled W-bead shielding:

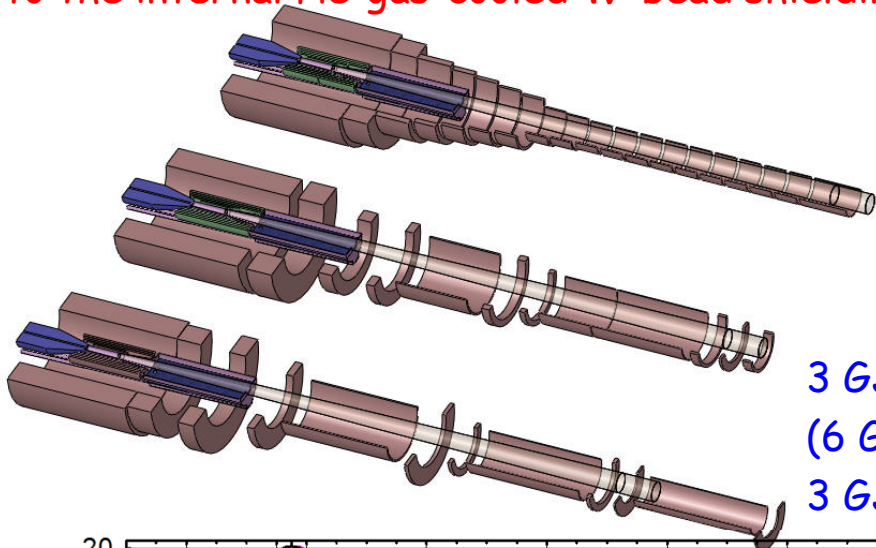

3 GJ stored magnetic energy  
(6 GJ in ITER Central Solenoid;  
3 GJ in LHC octant)

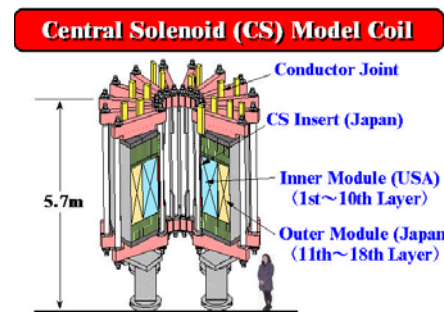
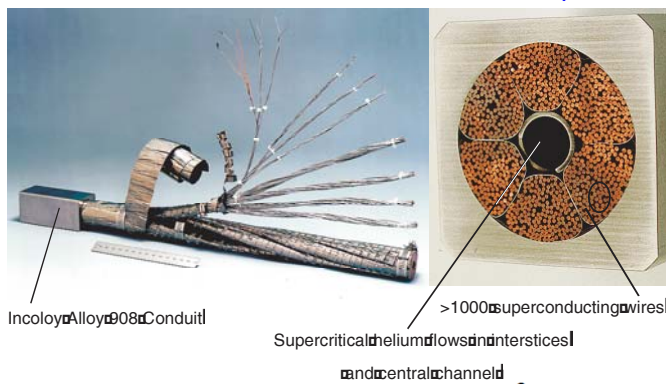
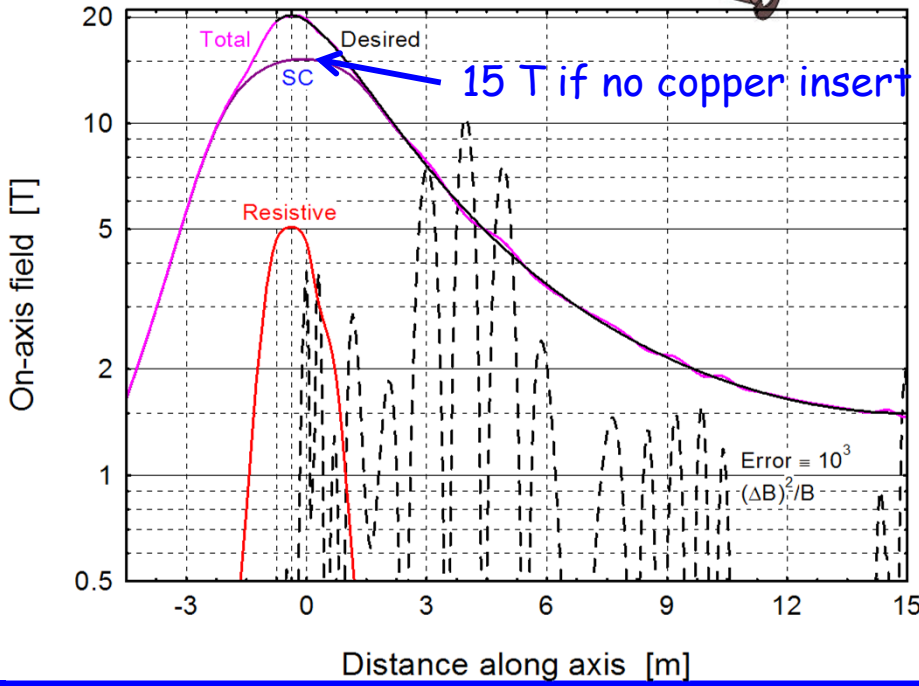

Shield mass ~ 200 tons,  
⇒ Sag when cantilevered.

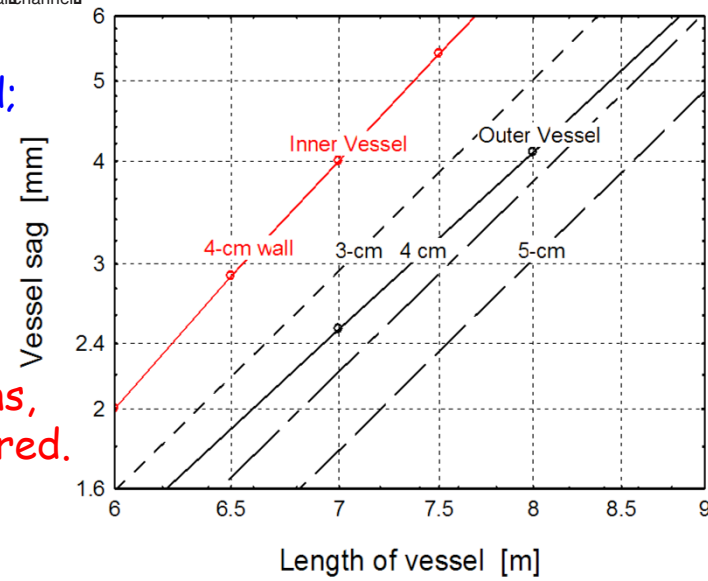

Shield module inside first SC magnet

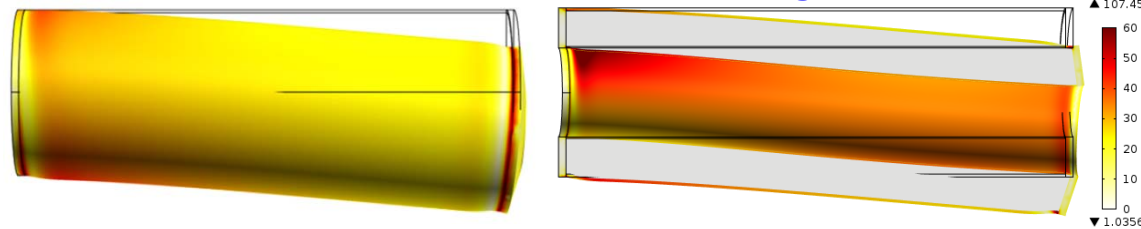



# Design of the Mercury-Handling System

(V.B. Graves, ORNL)

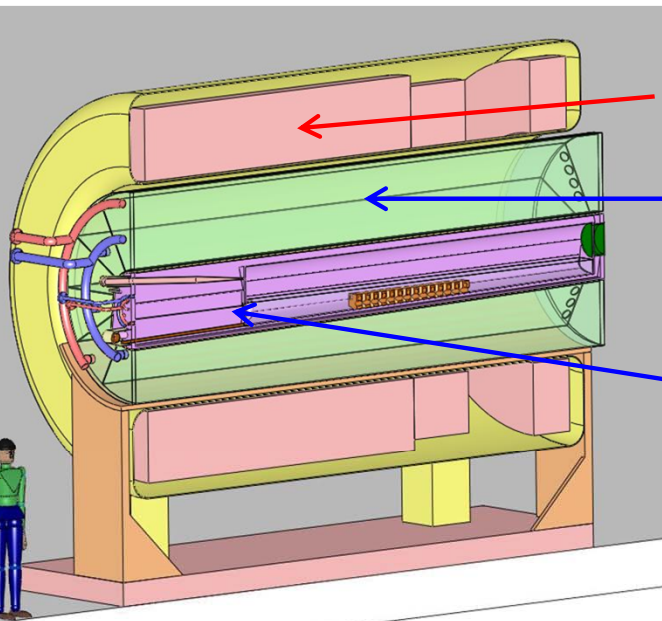

Superconducting magnet  
 Outer shielding module  
 Inner shielding module  
 Mercury target module

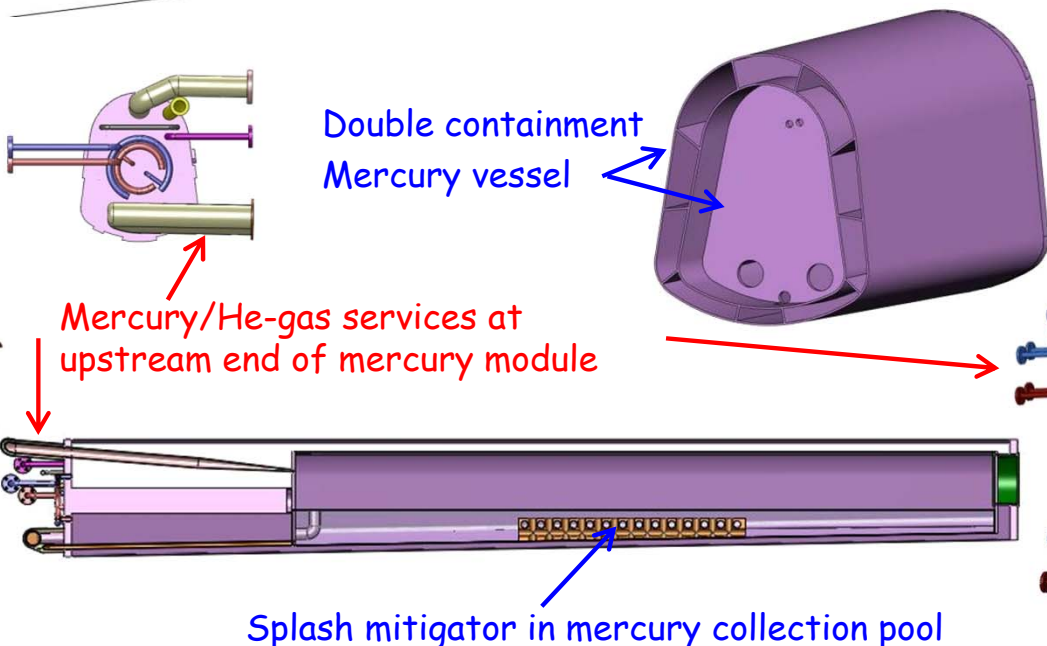
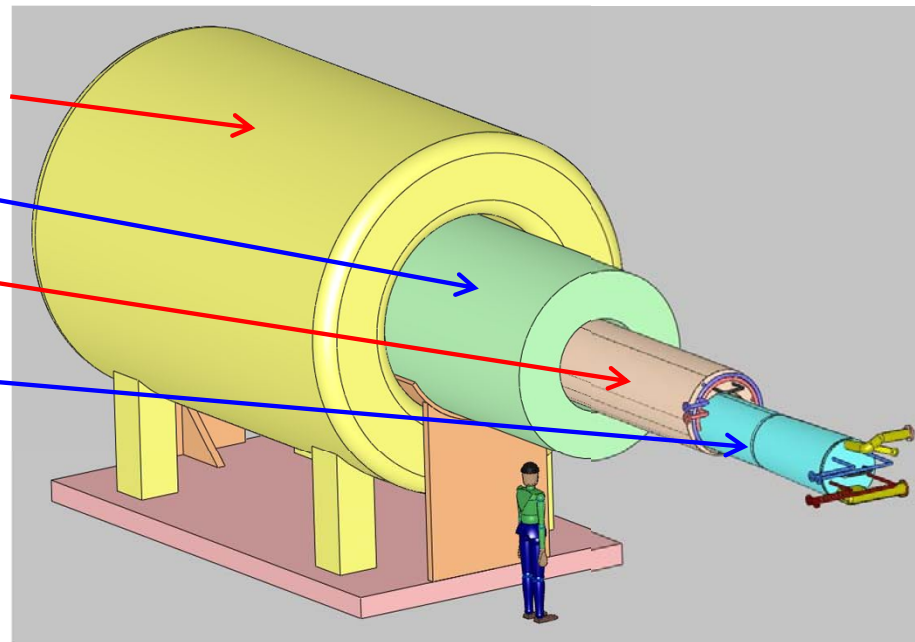

Double containment  
 Mercury vessel

Mercury/He-gas services at  
 upstream end of mercury module

Splash mitigator in mercury collection pool

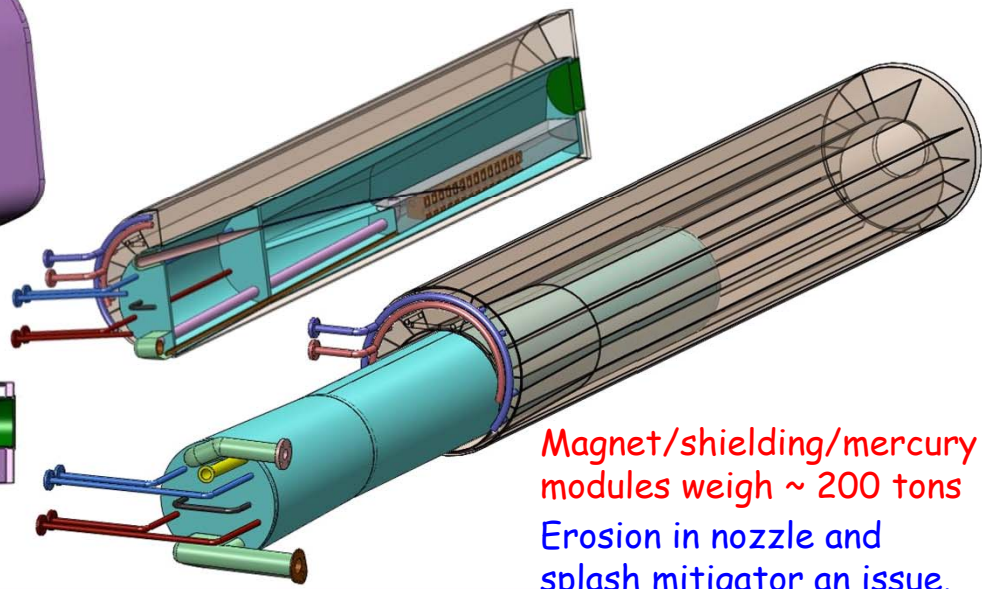

Magnet/shielding/mercury  
 modules weigh ~ 200 tons  
 Erosion in nozzle and  
 splash mitigator an issue.



# Targetry Effort in FY12-15



Targetry activities in FY13-15 will continue the engineering design studies listed on slide 6.

Beyond FY15: Similar level of effort, with addition of hardware studies of mercury-pool splash issues.

		FTEs			
		FY12	FY13	FY14	FY15
H. Kirk	(Admin)	0.7	0.7	0.7	0.7
J.S. Berg	(Admin.)	0.1	0.1	0.1	0.1
H. Sayed	(Particle production)	1	1	1	1
K.T.M	(Admin.)	0	0.1	0.1	0.1
X. Ding	(Particle production)	0.4	0.4	0.4	0.4
Samulyak Grad.	(Beam/jet interaction)	1	1	1	1
Ladeinde Grad.	(Nozzle hydrodynamics)	1	1	1	1
V. Graves	(Mercury system)	0.15	0.3	0.3	0.3
N. Souchlas	(Energy deposition)	0.5	0.5	0.5	0.5
B. Weggel	(Magnet/shielding)	0.3	0.3	0.3	0.3
<b>Total FTEs</b>		<b>5.15</b>	<b>5.25</b>	<b>5.25</b>	<b>5.25</b>
		<b>M&amp;S (FY12 k\$)</b>			
BNL Travel		25	25	25	25
Princeton Travel		8.5	8.5	8.5	8.5
<b>Total M&amp;S</b>		<b>33.5</b>	<b>33.5</b>	<b>33.5</b>	<b>33.5</b>



# Backup





# Extract from A. Kurup's Sheet TCDCostSummary.xlsx



Name	Total Cost	Comments
Target Module	#####	Scaled from SNS
Magnets	#####	Estimated by Bob Weggel
Magnet Shielding	#####	Estimated by Bob Weggel
Quench Protection System		
Vacuum		
Cryogenics		
Diagnostics		
Controls and Interlocks		
Health and Safety		
Mechanical		
Decommissioning		
Remote Handling and Hot Cells	#####	Scaled from LBNE
Buildings, tunnels and Infrastructure	#####	Scaled from LBNE
<b>Total</b>	#####	USD



# Target Module Costs Scaled from SNS (ORNL)



<b>1.06 - Target Systems</b>	<b>116,396,901</b>
1.06.01 - Target Assemblies	14,402,190
1.06.02 - Moderator Systems	8,661,901
1.06.03 - Reflector Assemblies	7,900,655
1.06.04 - Vessel Systems	11,848,901
1.06.05 - Target Station Shielding	13,405,475
1.06.06 - Target Utility Systems	10,730,099
1.06.07 - Remote Handling Systems	14,348,362
1.06.08 - Controls	3,076,899
1.06.09 - Beam Dumps	3,066,529
1.06.10 - Technical Support	12,896,977
1.06.11 - ORNL Field Coordination	16,058,914

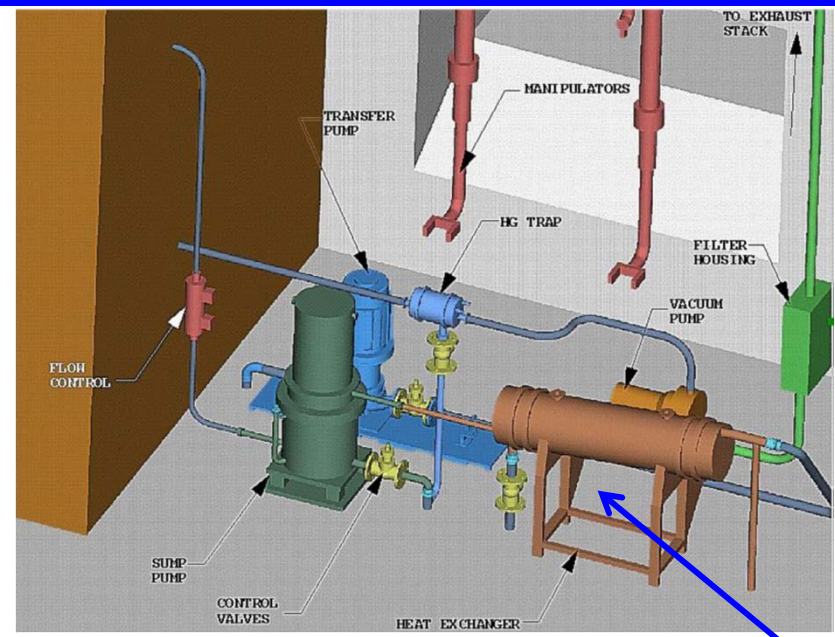

Neutrino Factory Study 2 concept

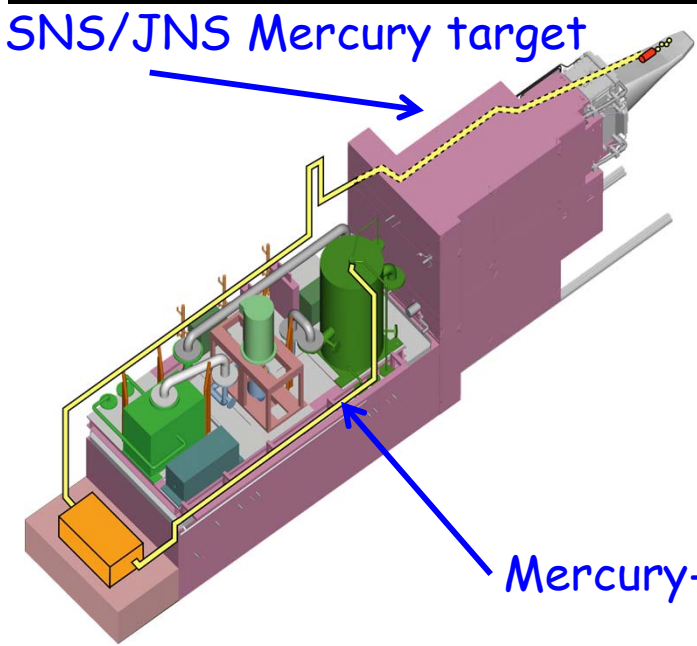

Mercury-loop utilities

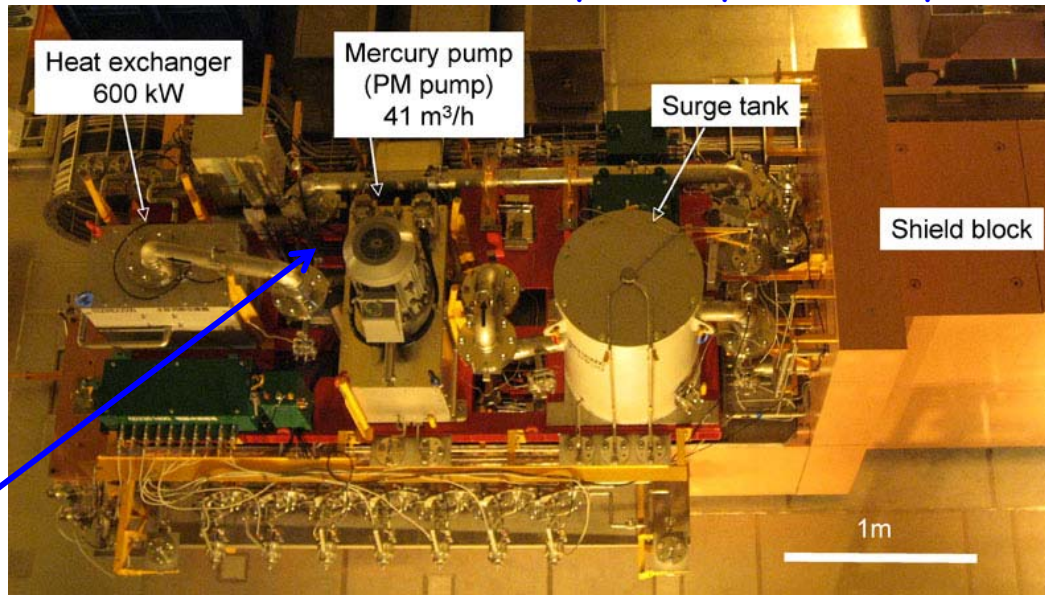



# Magnet and Shielding Costing by Bob Weggel



20-T, 120-cm-I.R. Target Magnets with Large Axial Gaps at 4, 10, 15 & 20 m

Bob Weggel, Magnet Optimization Research Engineering, LLC  
3/22/2012

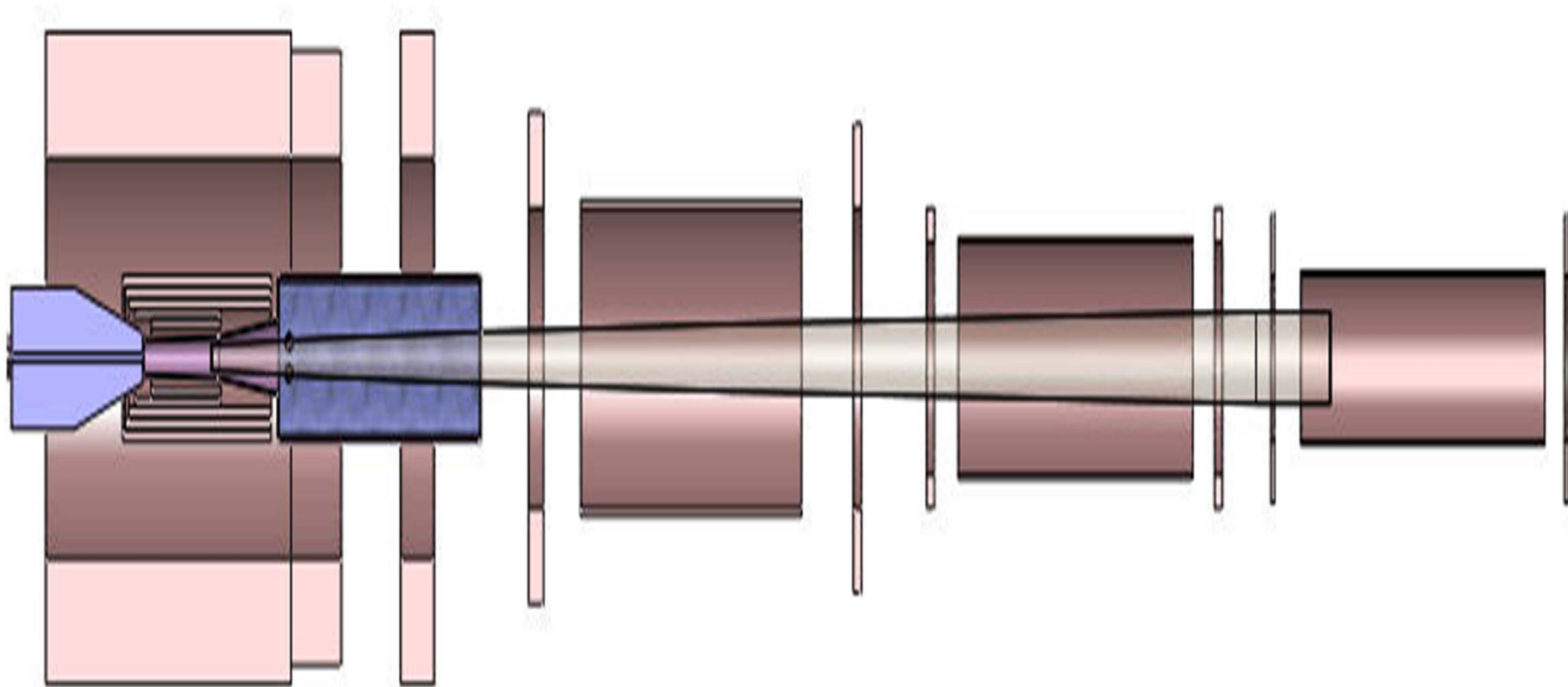

Target Magnet IDS120j: three solenoids per cryostat; large axial gaps at  $z = 4, 10, 15$  &  $20$  m [drawing courtesy Van Graves]. Target Magnet IDS120k is very similar, but the outboard solenoids in all cryostats except the first are of optimized (larger) inner radius, to improve field profile.  $U = 3.34$  GJ.



## Selected Parameters of Target Magnet IDS120k

	12.47	kA	0.1	meters	$\Delta L_{elec}$	1.724	$\mu\Omega\text{cm}$ at 20 °C	7.0	n $\Omega\text{cm/deg}$	10.0	°C T <sub>0</sub>	40.0	atmospheres $\Delta P$	0.10m	$\Delta L_{hy}$					
		Units		Cu 1	Cu 2	Cu 3	Cu 4	Cu 5	SC 1	SC 2	SC 3	SC 4	SC 5	SC 6	SC 7	SC 8	SC 9	SC 10	SC 11	SC 12
Coil designation																				
SSt shell thickness		cm		0.255	0.325	0.183	0.160	0.145												
Current density $j_{\lambda\text{-coil}}$		kA/cm <sup>2</sup>	5.00	2.201	2.074	1.412	1.204	1.059	1.931	2.176	2.673	3.346	4.122	4.072	4.503	4.666	4.645	4.645	4.645	4.645
Coil length		cm		100.2	123.6	207.2	212.0	215.6	352.3	77.78	45.20	31.23	255.4	15.45	13.00	341.3	10.96	14.12	320.3	14.12
Gap between coils		cm							0.00	87.30	148.6	74.28	83.20	105.0	37.31	27.89	70.76	39.71	39.71	72.00
Upstream end		cm		-87.6	-111.0	-121.0	-125.8	-129.5	-240.9	111.4	276.5	470.2	575.7	914.3	1035	1085	1454	1536	1590	1950
Downstream end		cm		12.6	12.6	86.2	86.2	86.2	111.4	189.2	321.7	501.5	831.1	929.8	1048	1426	1465	1550	1910	1964
Inner radius		cm		18.34	23.85	29.58	36.21	43.30	120.0	120.0	120.0	120.0	89.65	118.3	72.36	69.92	69.94	71.88	50.08	71.88
Radial depth of conductor		cm		4.760	4.903	5.943	6.435	6.861	75.83	64.34	75.83	55.63	4.155	52.02	14.55	2.456	16.45	18.12	2.334	18.12
Outer radius		cm		23.10	28.76	35.52	42.64	50.16	195.8	184.3	195.8	175.6	93.81	170.3	86.91	72.38	86.39	90.00	52.42	90.00
Volume, inc. SSt shell		m <sup>3</sup>	39.93	0.066	0.108	0.260	0.347	0.444	26.51	4.79	3.40	1.61	0.61	0.73	0.09	0.37	0.09	0.13	0.24	0.13
Maximum on-axis field		T		20.22	19.01	17.89	16.88	15.97	15.13	13.54	8.29	4.77	3.58	2.17	1.90	1.77	1.53			
SC $\gamma$ , MPa & fr.	6.00	none	0						0.093	0.070	0.029	0.018	0.017	0.011	0.011	0.011	0.010	0.010	0.010	0.010
Cu $\gamma$ , MPa & fr.	8.95	100	0	0.550	0.550	0.550	0.550	0.550	0.154	0.174	0.214	0.268	0.330	0.326	0.360	0.373	0.372	0.372	0.372	0.372
SSt $\gamma$ , MPa & fr.	7.80	700	700	0.051	0.062	0.030	0.024	0.021	0.521	0.495	0.436	0.313	0.159	0.174	0.088	0.056	0.061	0.061	0.061	0.061
SSt cm & SC M\$	30M	\$87.5	0.000	0.256	0.326	0.183	0.160	0.145	\$74.2	\$10.0	\$2.96	\$1.76	\$0.62	\$0.49	\$0.06	\$0.25	\$0.05	\$0.08	\$0.014	\$0.08
Coil tons		\$/m <sup>3</sup>	6.50	224.4	0.356	0.583	1.382	1.835	2.344	159.0	27.92	18.07	7.80	2.56	3.12	0.37	1.41	0.34	0.49	0.92
M\$@\$400/kg	0.40	\$2.60	\$89.8	4	4	4	4	4	paths/layer											
Magnet MW or MA-m	77.26	86.49	1.53	2.28	2.58	2.46	2.41	51.19	10.41	9.09	5.40	2.52	2.97	0.43	1.75	0.41	0.60	1.12	0.60	

Coil dimensions are in rows 3 through 11. Anticipated for the complete magnet, but not tabulated above, are an additional seven sets of three solenoids each that repeat solenoids SC #10, SC #11 and SC #12 at multiples of 5 m, to a distance z = 50 m. The cost estimates in the columns with first-row entries “kA” and “0.1” include solenoids to z = 20 m.

The cost of each solenoid is based on its mass of superconductor (if any), copper, stainless steel and insulation. The assumed unit cost of fabricated Nb<sub>3</sub>Sn (SC #1-#3) is 30 M\$/m<sup>3</sup>; that of NbTi (SC #4 and up) is \$X M\$/m<sup>3</sup>. The assumed cost of copper, stainless steel and insulation is \$X/kg. Costs of cryostats, shielding vessels, shielding and other components have yet to be estimated.

The estimated cost of the resistive magnet is 6.50 metric tonnes x \$X/kg = \$Y M. The cost of SC#1 is the sum of two components: superconducting and non-superconducting. The non-superconducting cost is 159.0 tonnes x \$X/kg = Y M\$. The cost attributed to the superconductor is 26.51 m<sup>3</sup> x 0.093 x Y M\$/m<sup>3</sup> = Z M\$, for a total of \$X. M\$.

The non-superconducting unit cost of \$X/kg compares to the \$Y/kg reported for resistive magnets at the National High Magnetic Field Laboratory (NHMFL) at Tallahassee, Florida. The superconducting unit cost of Z M\$/m<sup>3</sup> approximately doubles the non-superconducting unit cost a superconducting magnet. The average unit cost for all the superconducting magnets is X M\$ / 224.4 tonnes = \$Y/kg. This compares with the \$Z/kg reported for superconducting and hybrid magnets at the NHMFL.

*Wegge's cost estimate agrees to within 2% with the Green-Strauss algorithm (A. Bross).*



# Target Hall

A major cost driver will be civil construction and shielding.

LBNE 2-MW target station  
~ \$175m

Crude sketch to start IDS-NF costing

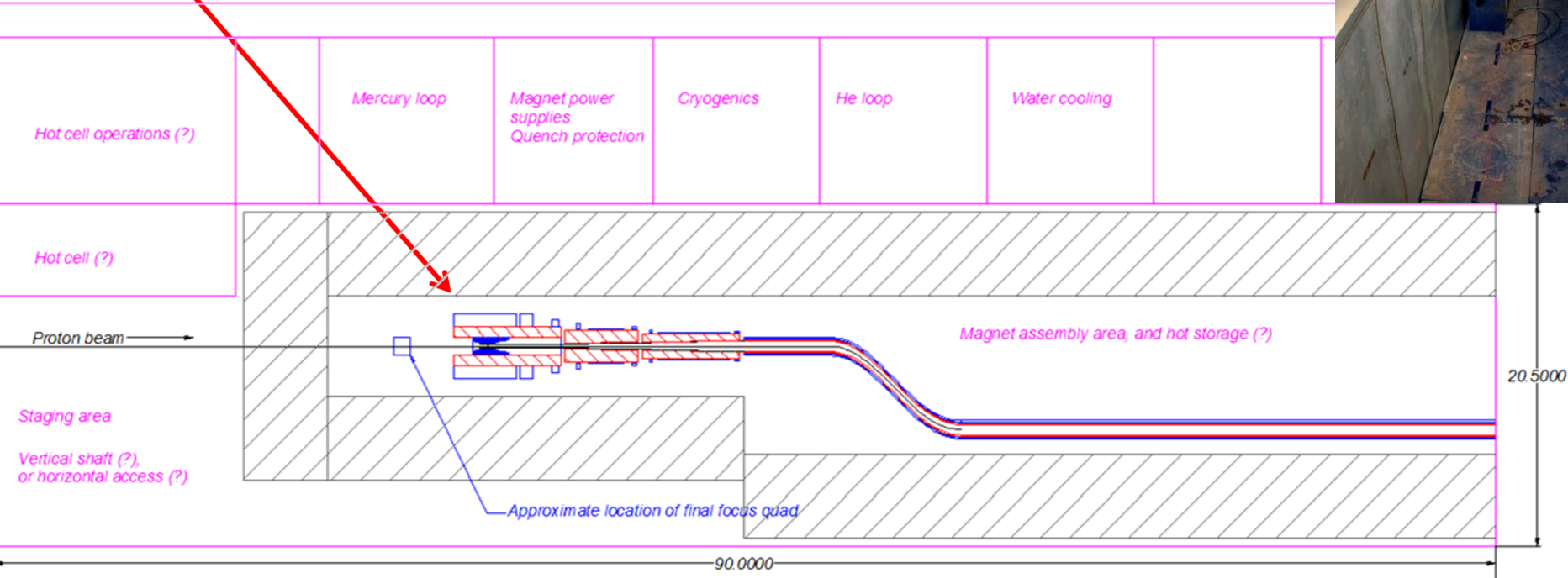
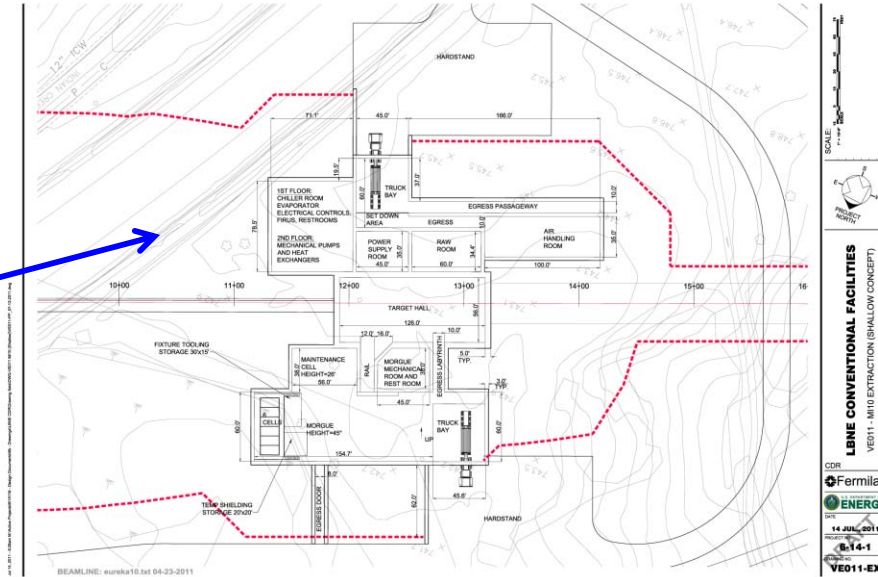

Concrete shielding assumed to be 5 m thick, => floor also 5 m thick, and 5 m shielding above the beamline

200 ton bridge crane, hook height ~ 10 m, => building height ~ 15 m



# Neutrino Factory Study 2 Concepts

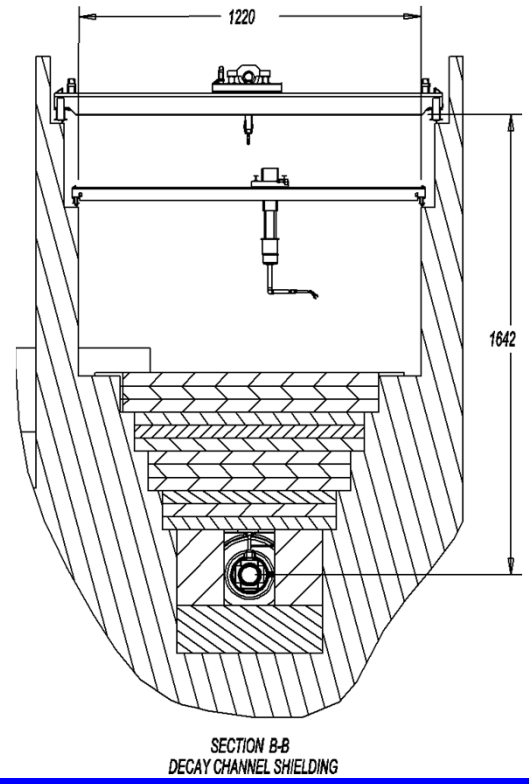
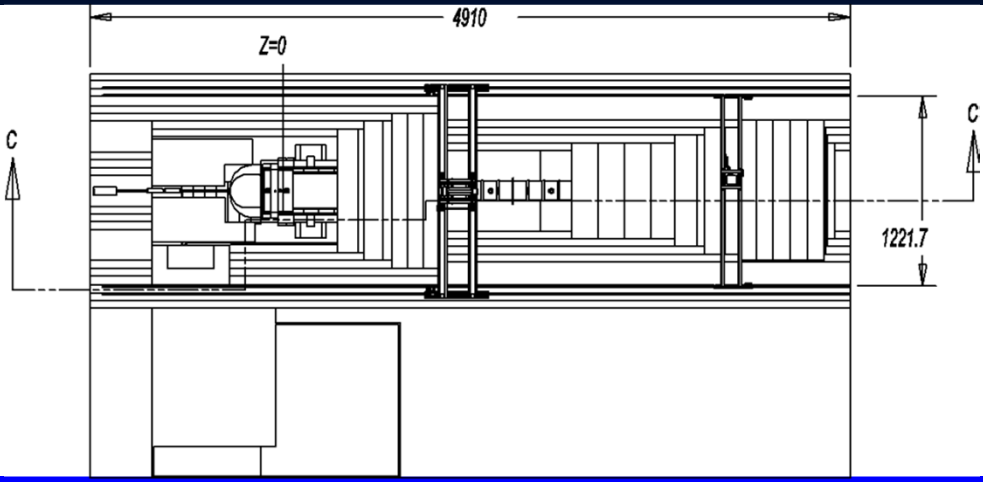
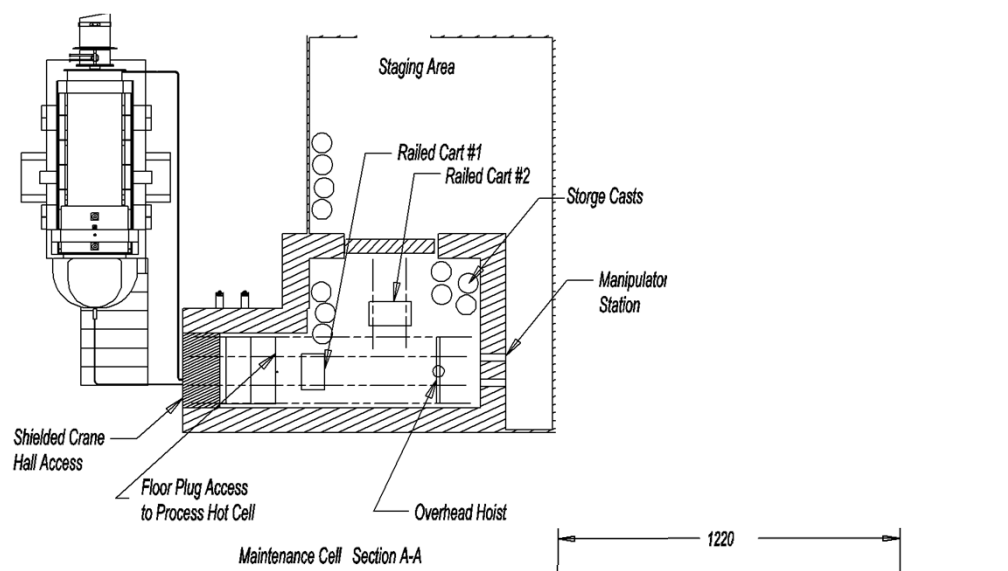
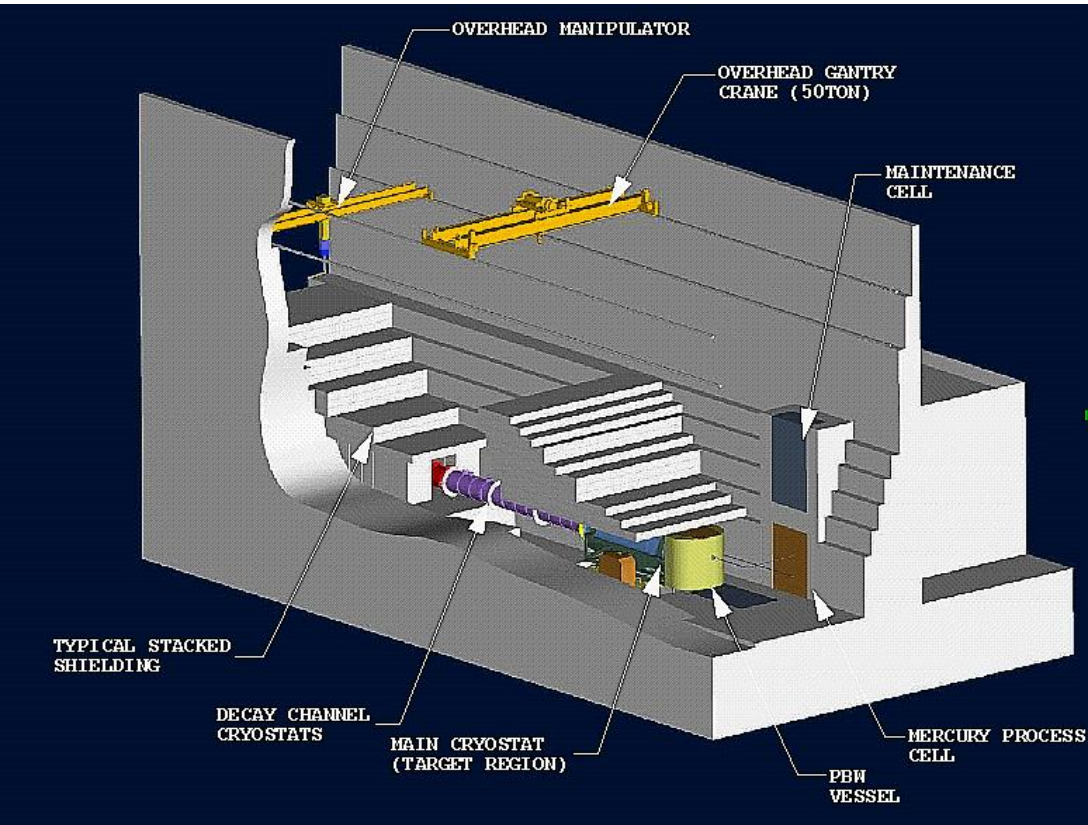



# LBNE Target Hall Concept

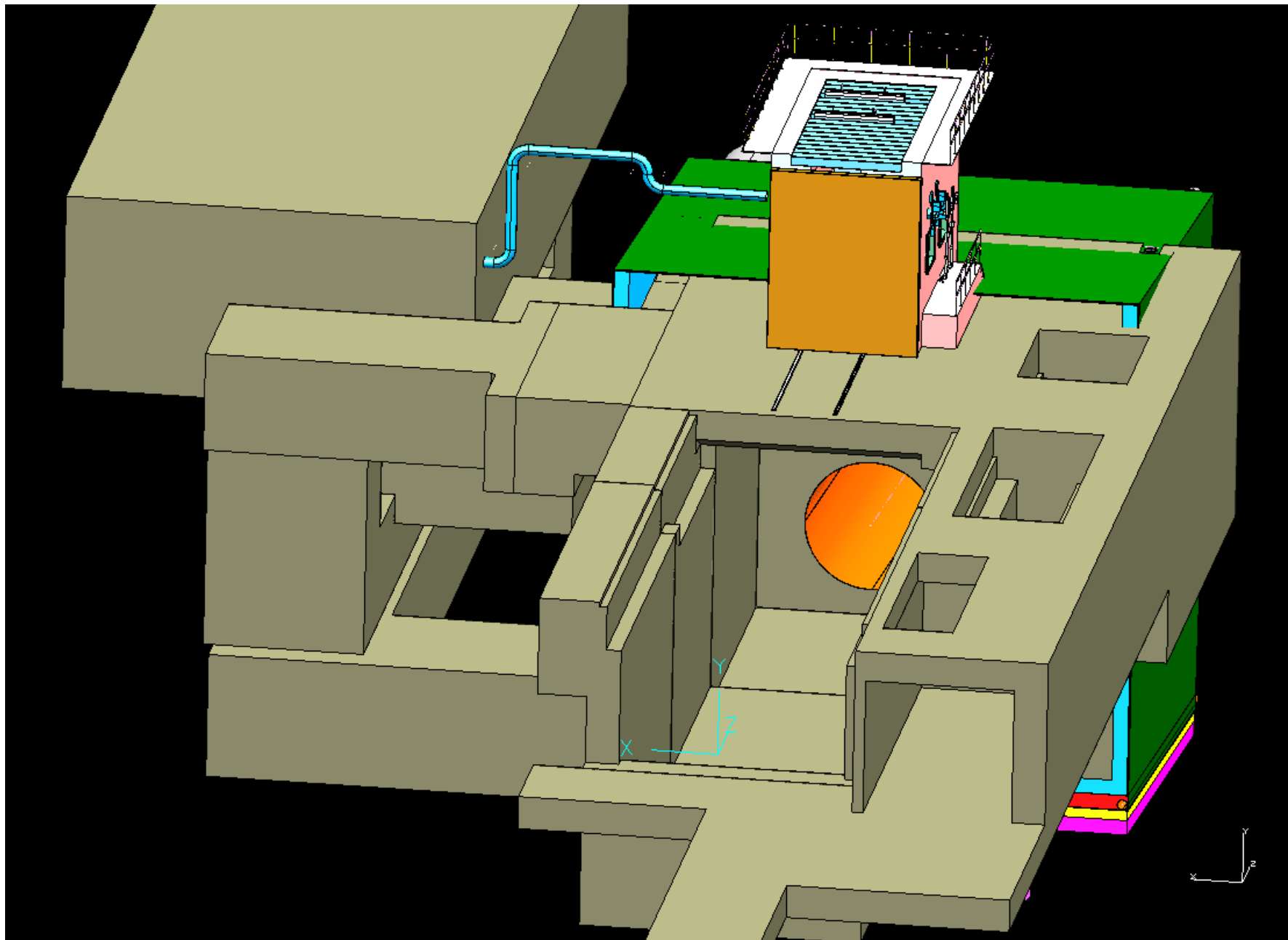



# LBNE 20 – TARGET COMPLEX Site Plan

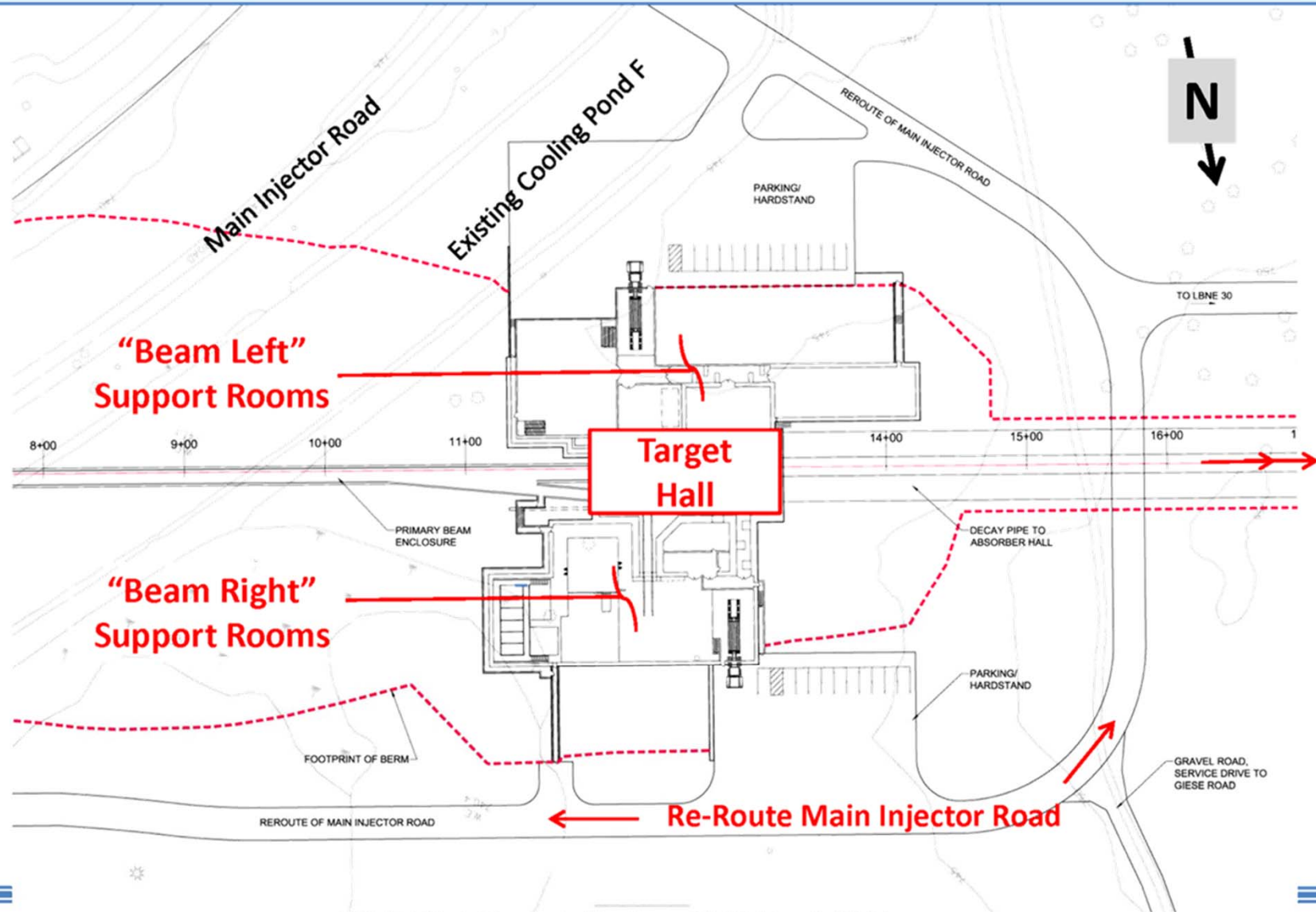

LBNE CD-1 Director's Review - 26-30 March 2012

15





# LBNE 20 – Target Complex

## Target Hall, Support Rooms, Service Rooms

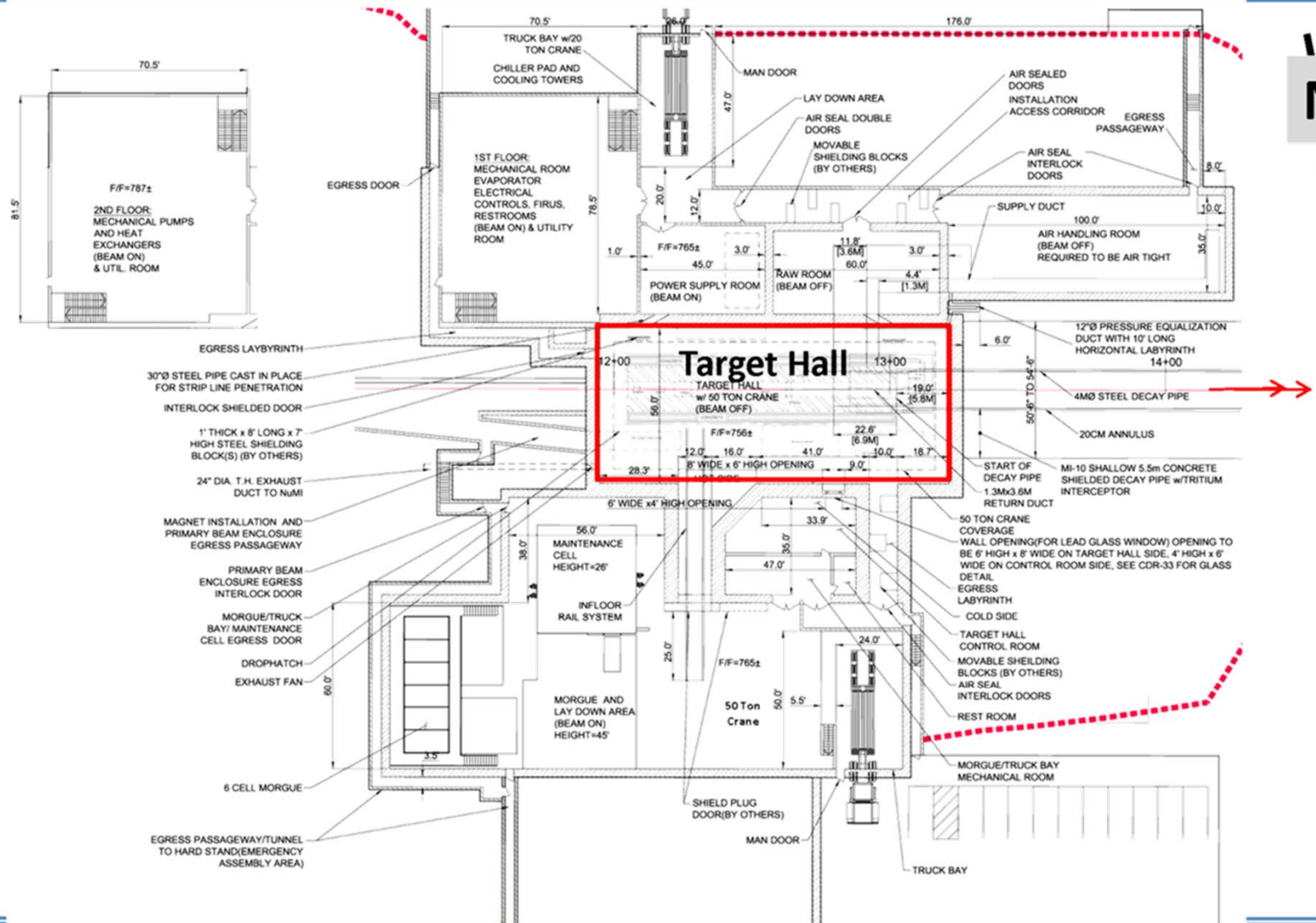

LBNE CD-1 Director's Review - 26-30 March 2012

16



# "Beam Left" Service and Support Rooms

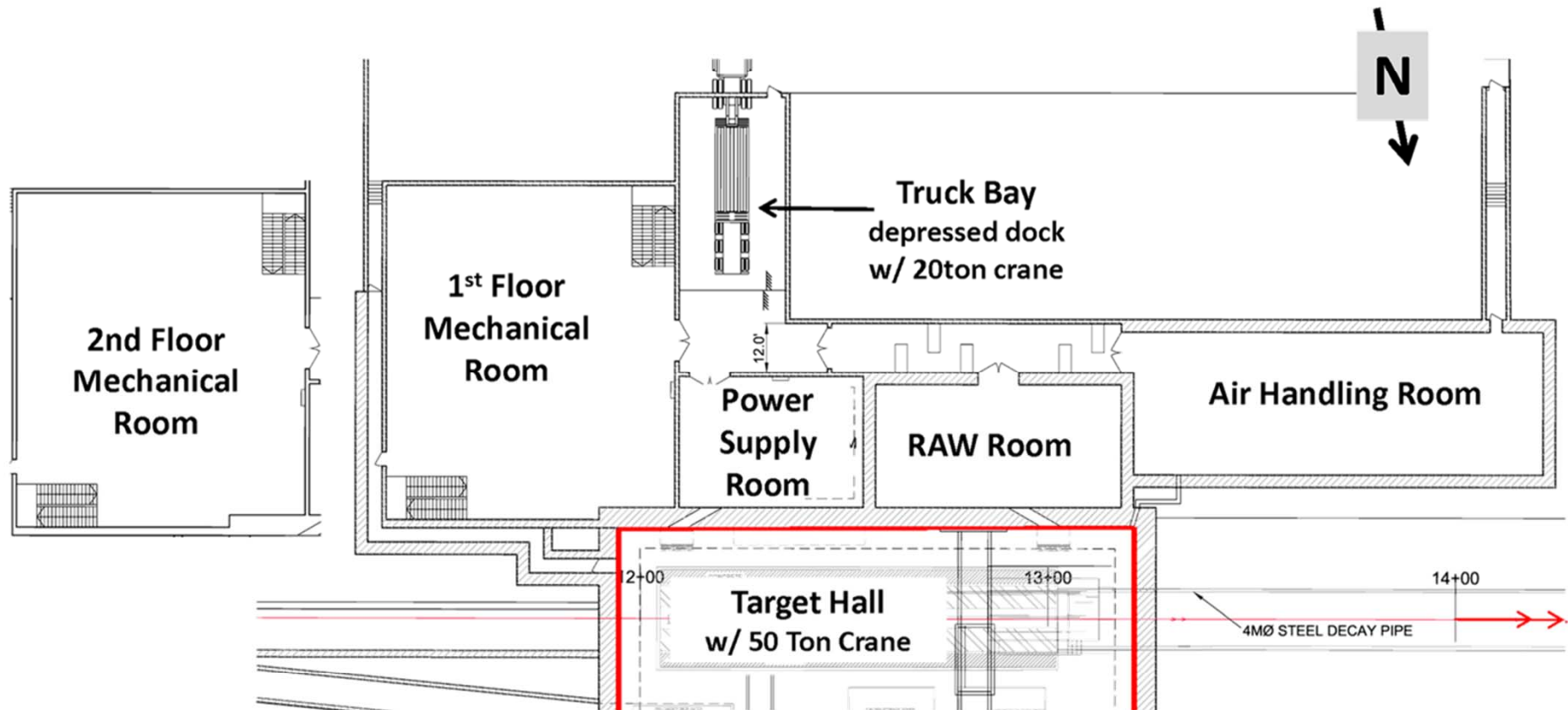

**Power Supply Room, RAW Room, Air Handling Room,  
Truck Bay, 2 Story Mechanical Wing**



# “Beam Right” Service and Support Rooms

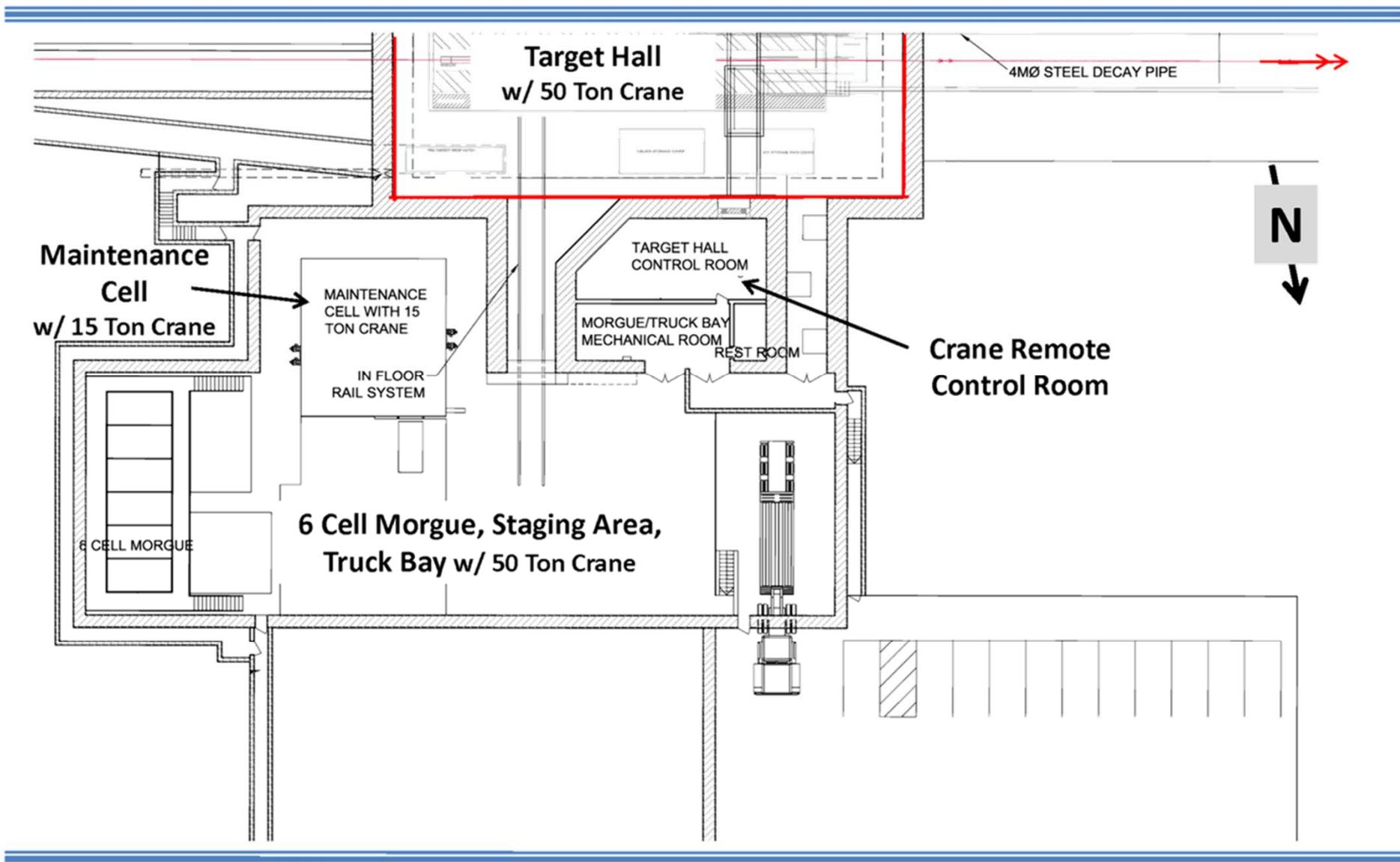

LBNE CD-1 Director's Review - 26-30 March 2012



# 130.06.02.05.04.03 Decay Pipe

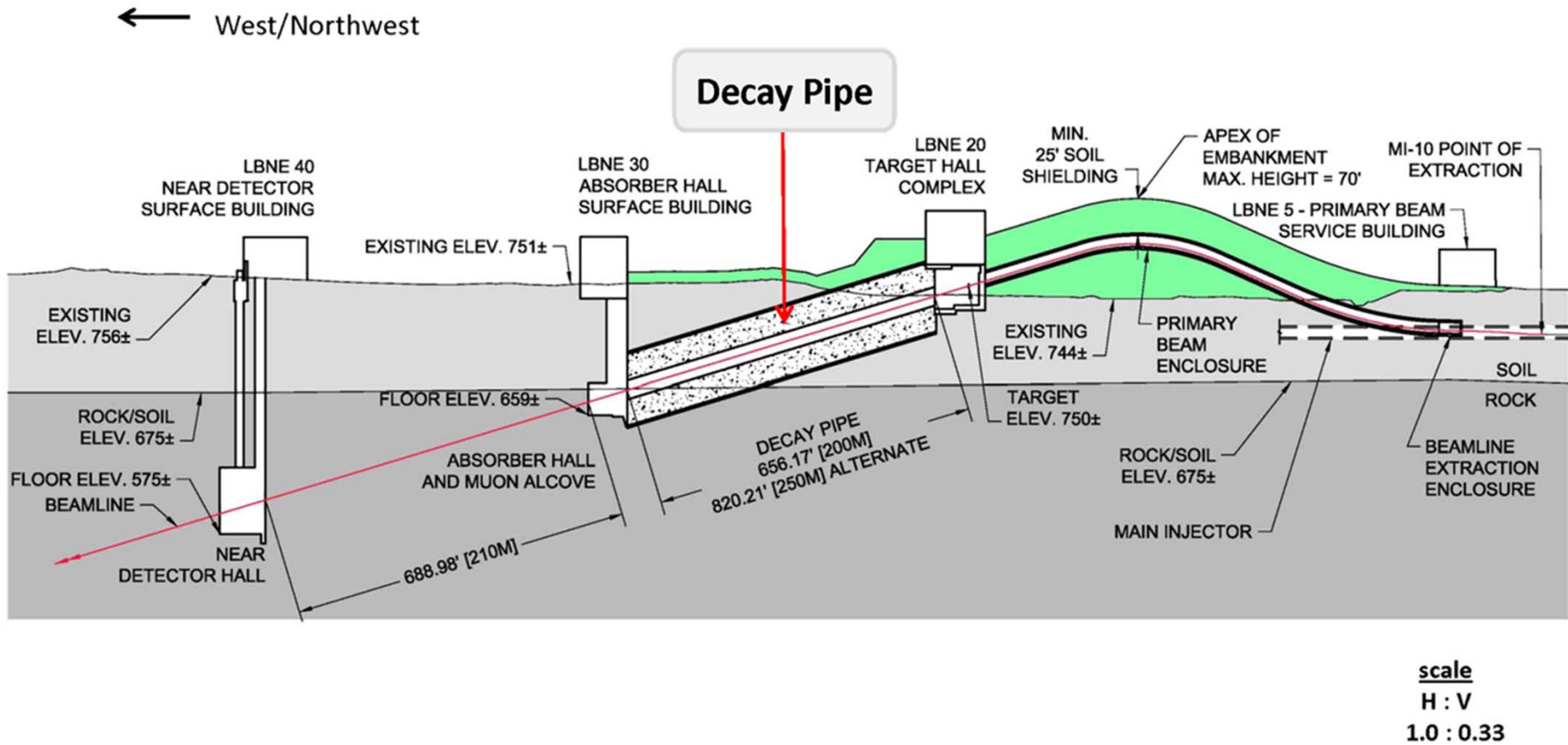

The NF Target System Hall is equivalent in many ways to the LBNE Decay Pipe.



# Decay Pipe Cross Section

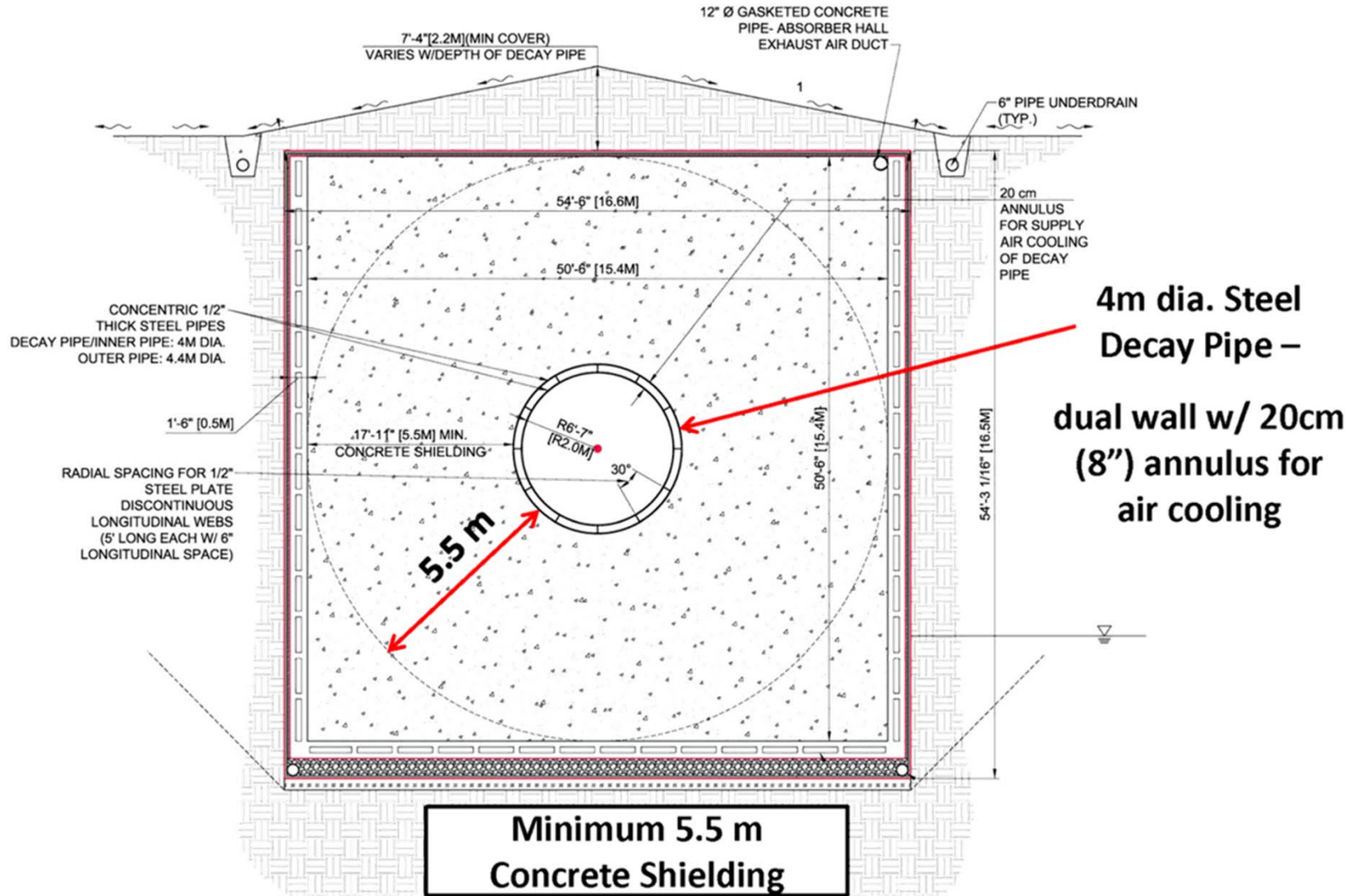

LBNE CD-1 Director's Review - 26-30 March 2012

36

We may need concrete shielding ~ 5.5 m thick around the entire target system.



# Decay Pipe Air Cooling Ducting at Target Hall

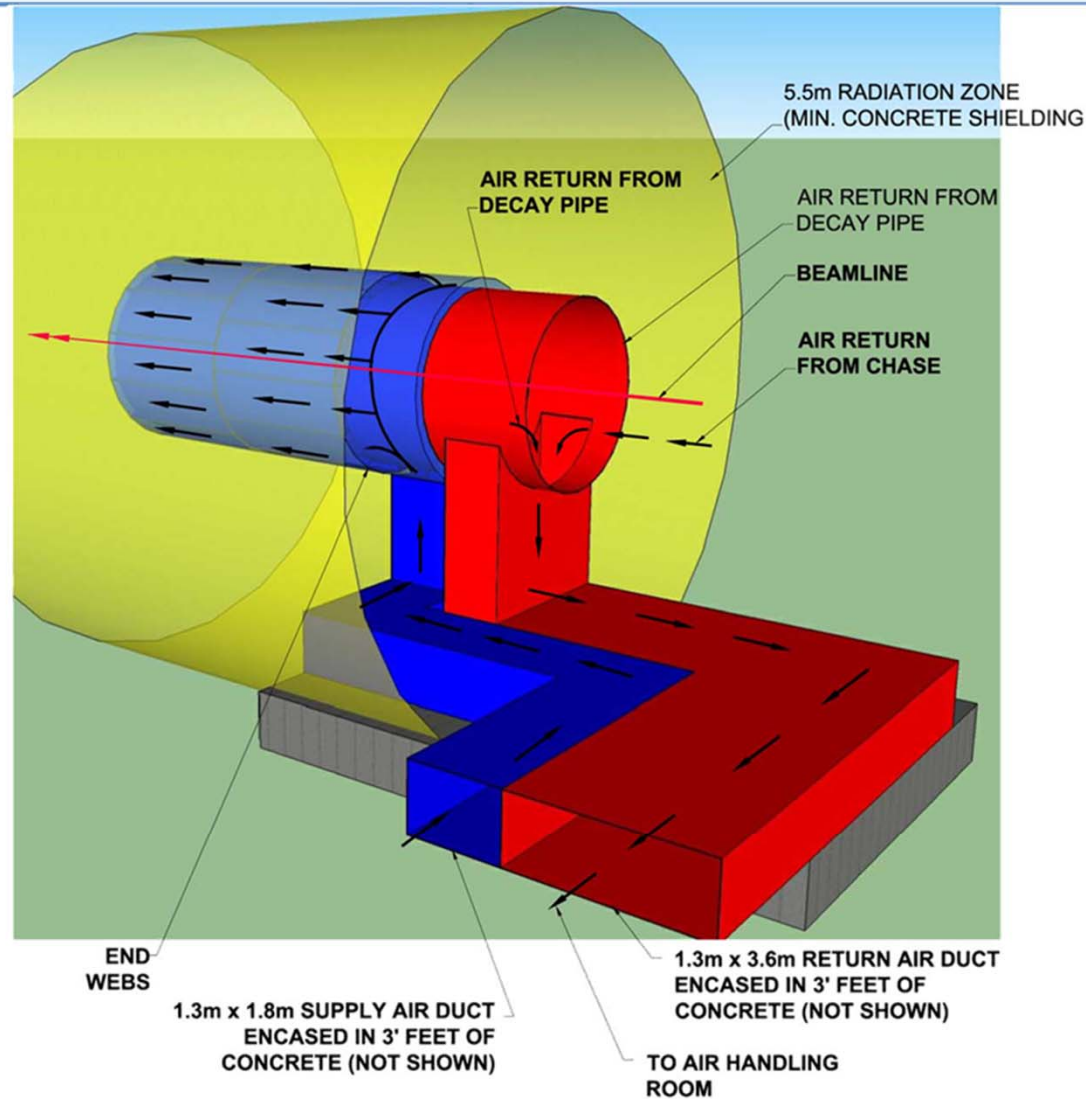

LBNE CD-1 Director's Review - 26-30 March 2012

37

We must have an activated-air-handling system for the Target System Hall.



# CERN MERIT Experiment



Proof-of-principle demonstration of a mercury jet target in a strong magnetic field, with proton bunches of intensity equivalent to a 4-MW beam.

Performed in the TT2A/TT2 tunnels at CERN, Nov. 2007.

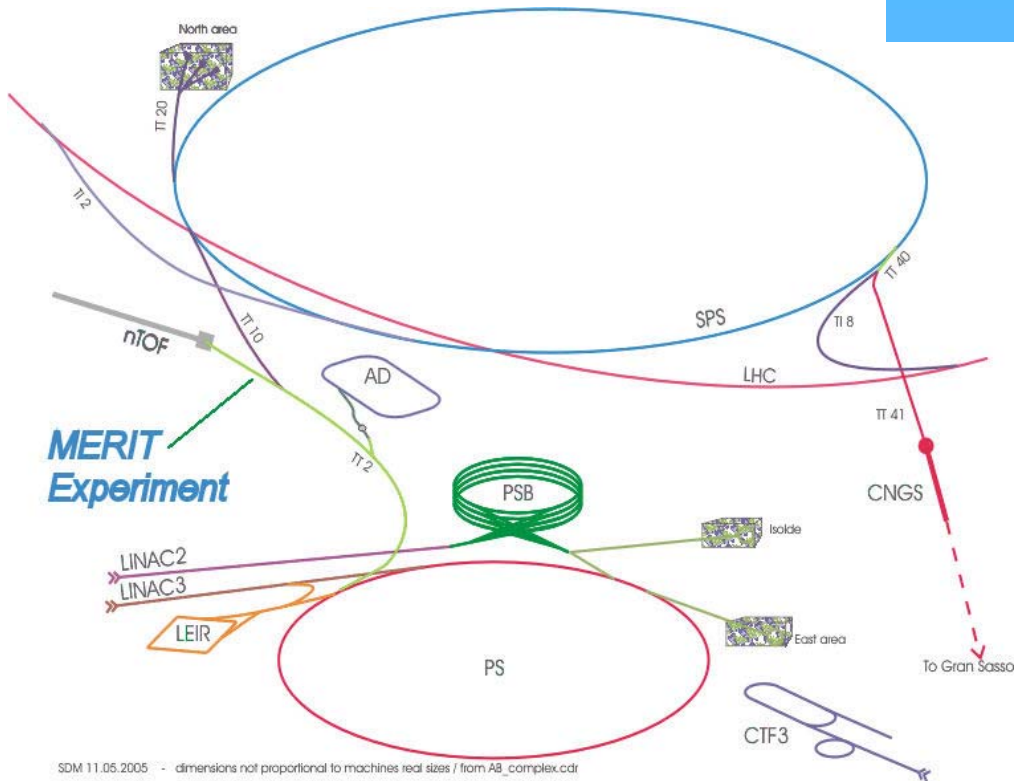
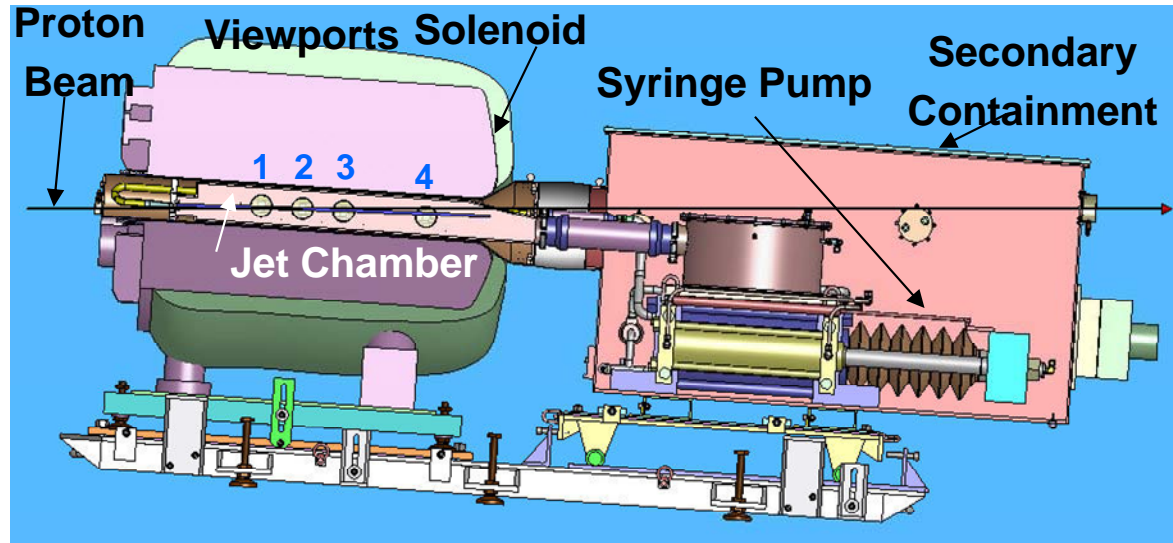

SDM 11.05.2005 - dimensions not proportional to machines real sizes / from AB\_complex.cdr



# Disruption Length Analysis (H. Park, PhD Thesis)



Observe jet at viewport 3 at 500 frames/sec, measure total length of disruption of the mercury jet by the proton beam.

Images for 10 T<sub>p</sub>, 24 GeV, 10 T:

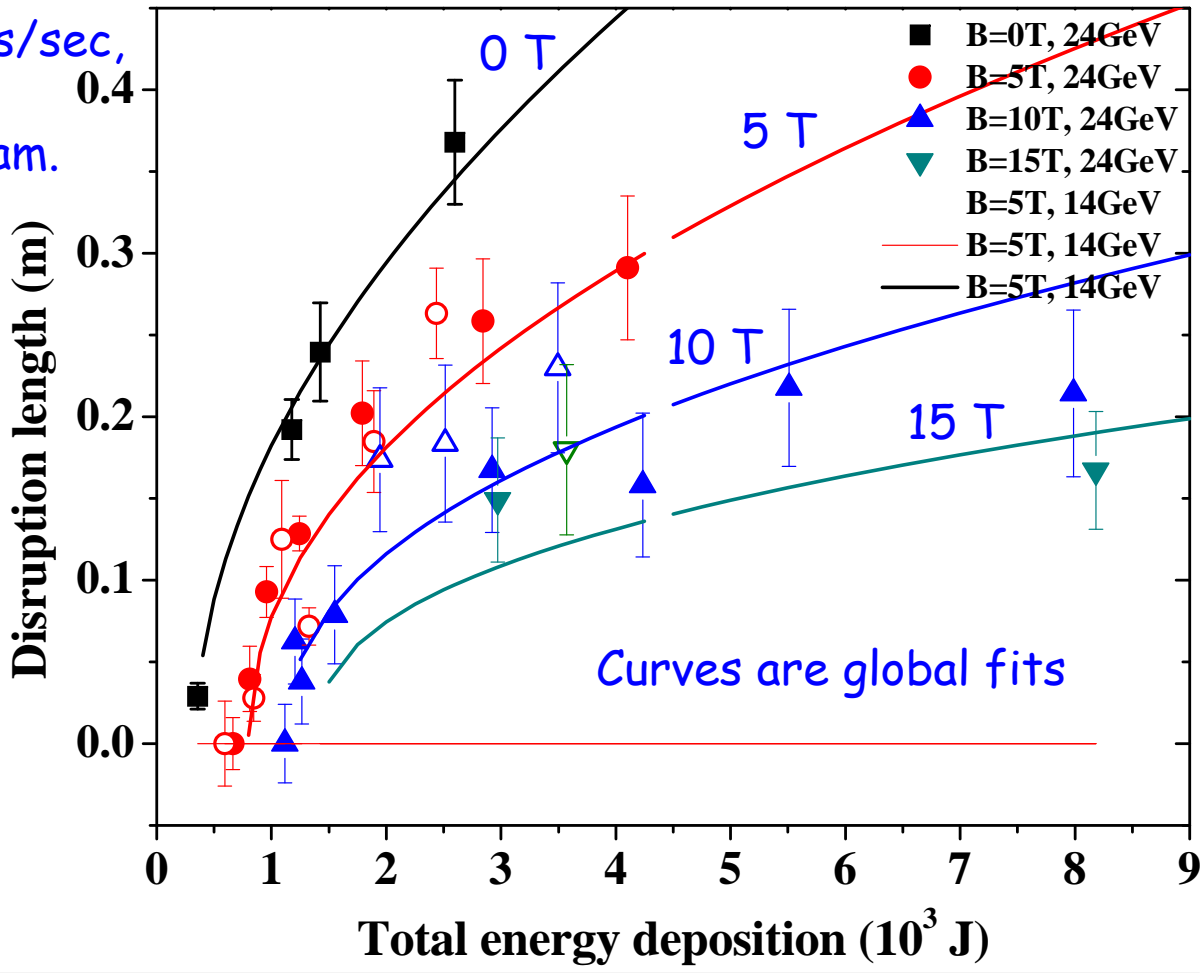
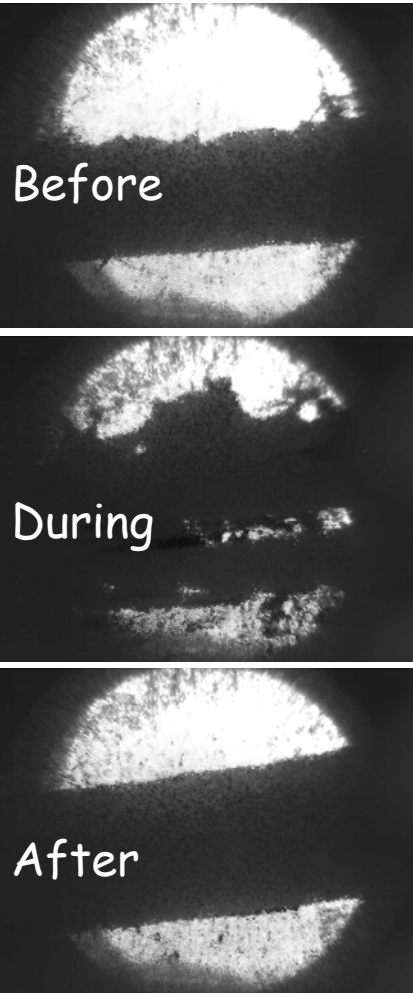

Disruption length never longer than region of overlap of jet with proton beam.

No disruption for pulses of < 2 T<sub>p</sub> in 0 T (< 4 T<sub>p</sub> in 10 T).

Disruption length shorter at higher magnetic field.





# Filament Velocity Analysis (H. Park)

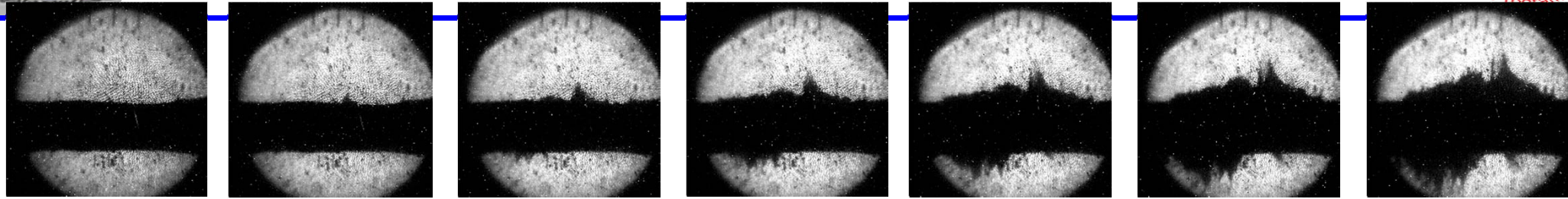

Measure position of tip of filament in each frame, and fit for  $t_v$  and  $v$ .

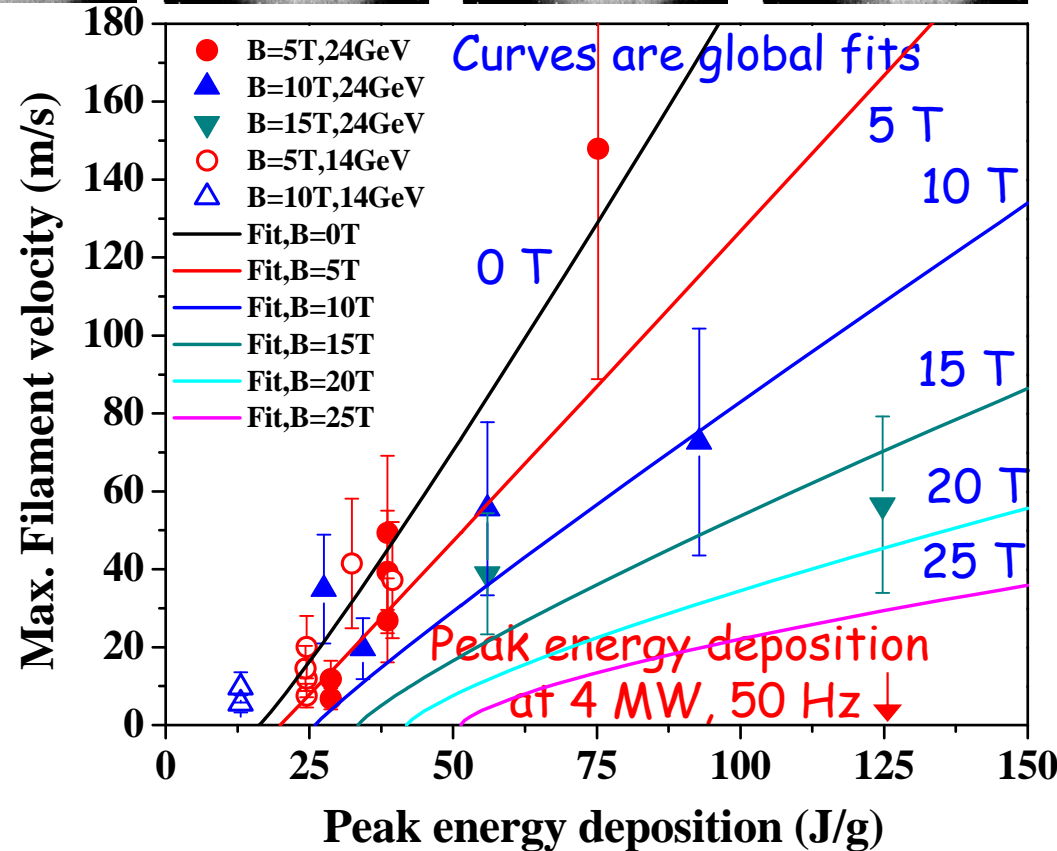
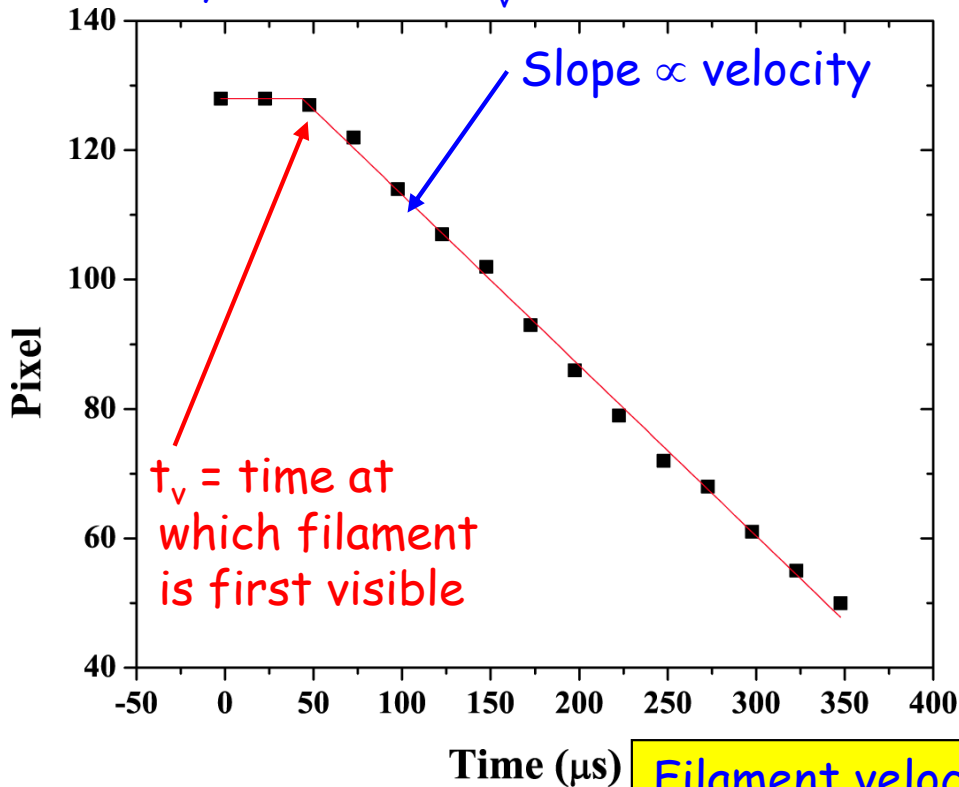

Filament velocity suppressed by high magnetic field.  
 Filament start time  $\gg$  transit time of sound across the jet.  
 $\Rightarrow$  New transient state of matter???



# Pump-Probe Studies

? Is pion production reduced during later bunches due to disruption of the mercury jet by the earlier bunches?

At 14 GeV, the CERN PS could extract several bunches during one turn (pump), and then the remaining bunches at a later time (probe).

Pion production was monitored for both target-in and target-out events by a set of diamond diode detectors.

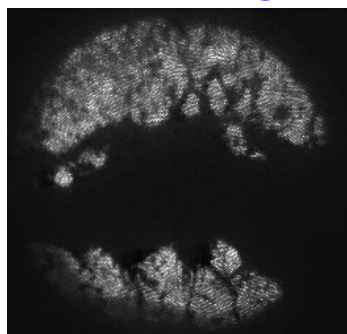
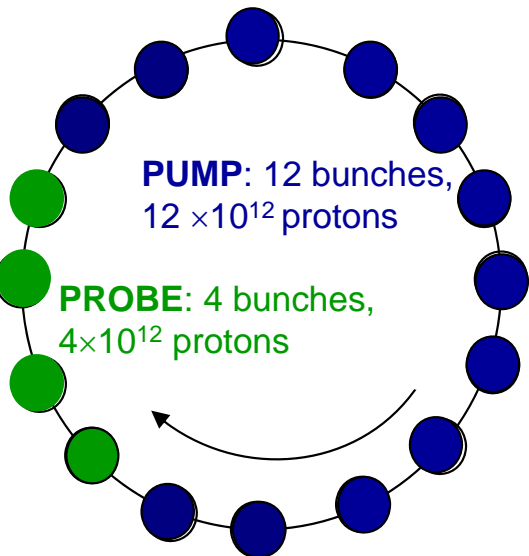

Single-turn extraction  
→ 0 delay, 8 T $\rho$

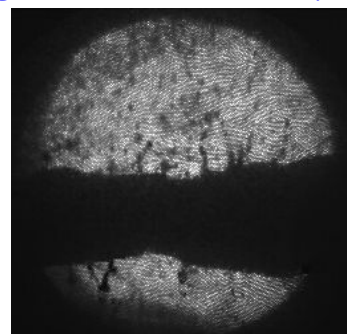

4-T $\rho$  probe extracted on next turn  
→ 3.2  $\mu$ s delay

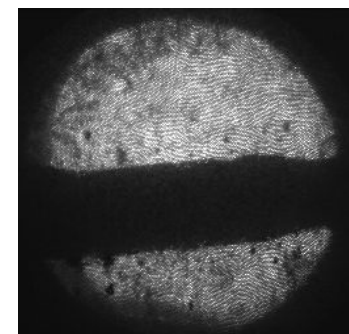

4-T $\rho$  probe extracted after 2nd full turn  
→ 5.8  $\mu$ s Delay

Ratio Target In-Out/Target Out

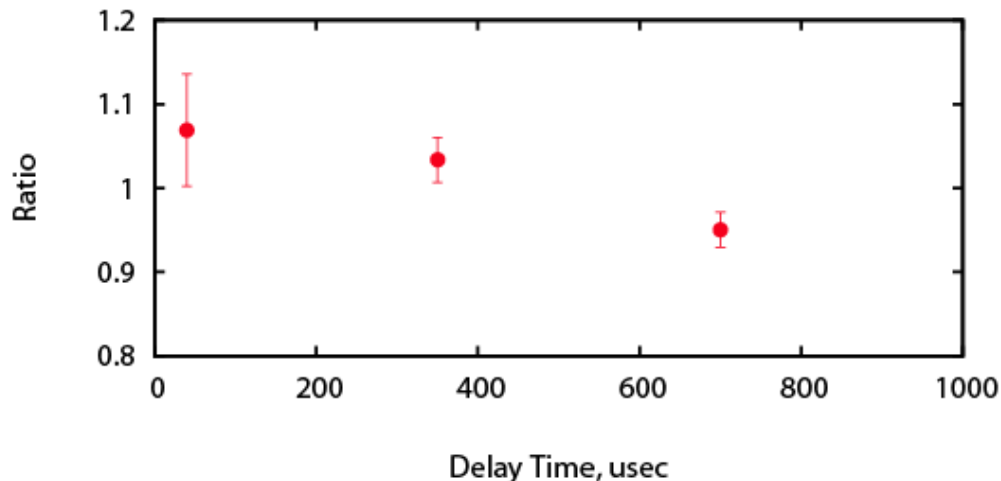

Results consistent with no loss of pion production for bunch delays of 40 and 350  $\mu$ s, and a 5% loss (2.5- $\sigma$  effect) of pion production for bunches delayed by 700  $\mu$ s.

$$\text{Ratio} = \frac{\frac{\text{Probe}_{\text{target in}} - \text{Probe}_{\text{target out}}}{\text{Pump}_{\text{target in}} - \text{Pump}_{\text{target out}}}}{\frac{\text{Probe}_{\text{target out}}}{\text{Pump}_{\text{target out}}}}$$