

Physics with a Neutrino Superbeam

- 1- TOP END CAP IRON YOKE
- 2- BOTTOM END CAP IRON YOKE
- 3- BARREL IRON RETURN YOKE
- 4- COIL
- 5- CRYOSTAT
- 6- CATHODES (N° 5)
- 7- WIRE CHAMBERS (N° 4)
- 8- FIELD SHAPING ELECTRODES

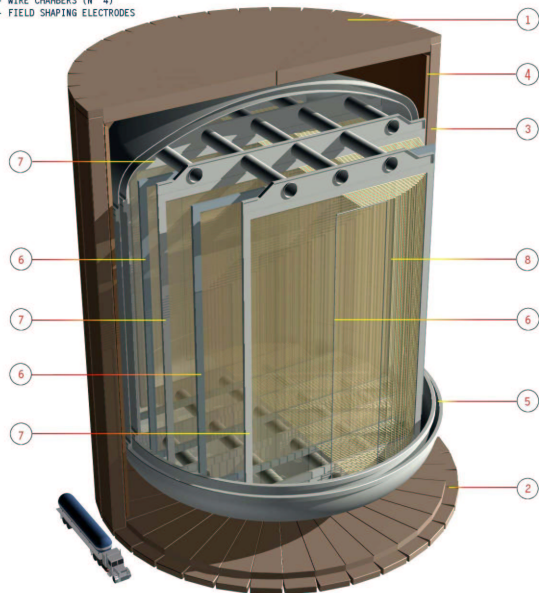

LANDD
Liquid Argon Neutrino and Nucleon Decay Detector

F. Sengulmetri-August 2000

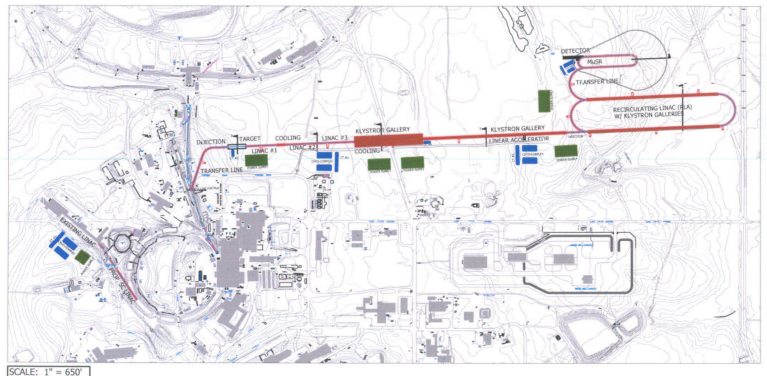

NEUTRINO FACTORY,
SITE PLAN

BROOKHAVEN
NATIONAL LABORATORY

Brookhaven Science Associates
U.S. Department of Energy

Kirk T. McDonald

Princeton U.

mcdonald@puphep.princeton.edu

Physics Colloquium at the University of South Carolina

November 1, 2001

<http://puhep1.princeton.edu/~mcdonald/nufact/>

Starting the Second Century of Neutrinos

- 1896 – Becquerel discovers radioactivity of uranium salts.
- 1899 – Rutherford identifies α and β radioactivity.
- 1914-1927 – Chadwick: the β energy spectrum is continuous.
- 1933 – Pauli: β decay involves a neutrino, $n \rightarrow p + e + \bar{\nu}_e$.
- 1934 – Fermi: theory of β decay with very light neutrinos.
- 1956 – Cowan and Reines detect the $\bar{\nu}_e$ via $\bar{\nu}_e + p \rightarrow e^+ + n$.
- 1957 – Pontecorvo: ν_e could oscillate into ν_μ .
- 1962 – Lederman, Schwartz and Steinberger detect the ν_μ .
- 1968 – Davis reports the first solar neutrino (ν_e) “deficit”.
- 1976 – Perl *et al.* discover the τ lepton; ν_τ is presumed to exist.
- 1990 – Γ_{Z^0} measured at LEP, \Rightarrow only 3 light, SM neutrinos.
- 1998 – Superkamiokande: ν_μ 's disappear over Earth distances.
- 2001 – SNO: Solar neutrino deficit due to neutrino oscillations.

There are 3 known types of neutrinos, ν_e , ν_μ , and ν_τ , which are partners to the three charged leptons e , μ , and τ .

Oscillations of Massive Neutrinos

Neutrinos could have a small mass (Pauli, Fermi, Majorana, 1930's).

Massive neutrinos can mix (Pontecorvo, 1957).

In the example of only two massive neutrinos (that don't decay), with mass eigenstates ν_1 and ν_2 with mass difference Δm and mixing angle θ , the flavor eigenstates ν_a and ν_b are related by

$$\begin{pmatrix} \nu_a \\ \nu_b \end{pmatrix} = \begin{pmatrix} \cos \theta & \sin \theta \\ -\sin \theta & \cos \theta \end{pmatrix} \begin{pmatrix} \nu_1 \\ \nu_2 \end{pmatrix}.$$

The probability that a neutrino of flavor ν_a and energy E appears as flavor ν_b after traversing distance L in vacuum is

$$P(\nu_a \rightarrow \nu_b) = \sin^2 2\theta \sin^2 \left(\frac{1.27 \Delta m^2 [\text{eV}^2] L [\text{km}]}{E [\text{GeV}]} \right).$$

The probability that ν_a does not disappear is

$$P(\nu_a \rightarrow \nu_a) = \cos^2 2\theta \sin^2 \left(\frac{1.27 \Delta m^2 [\text{eV}^2] L [\text{km}]}{E [\text{GeV}]} \right).$$

A Sketch of Current Data

- The **Atmospheric Neutrino “Anomaly”** suggests that GeV ν_μ 's (from $p+N_2 \rightarrow \pi \rightarrow \mu\nu_\mu$) disappear while traversing the Earth's diameter, $\Rightarrow \Delta m^2 \approx 10^{-3} \text{ (eV)}^2$ for $\sin^2 2\theta \approx 1$.
(Kamiokande, IMB, Soudan-2, MACRO, Super-Kamiokande)

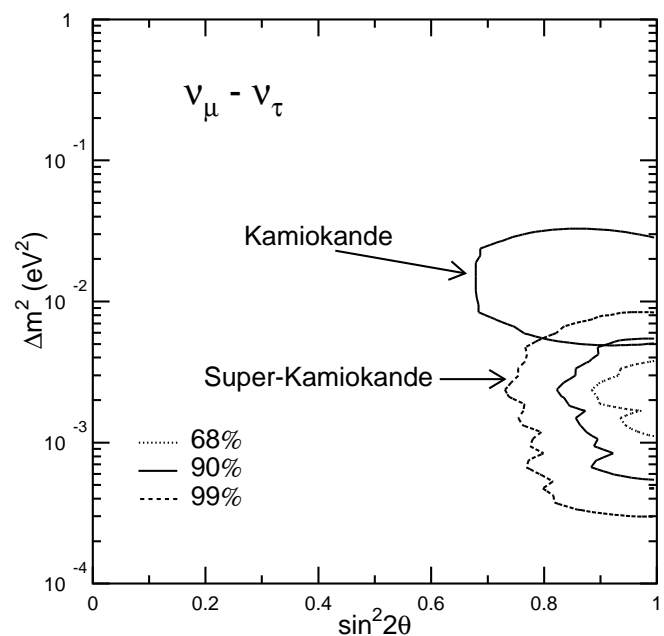
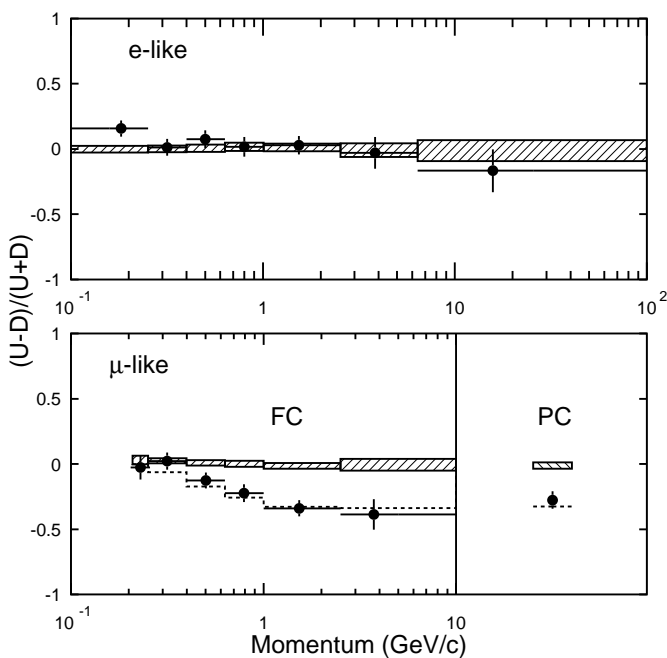
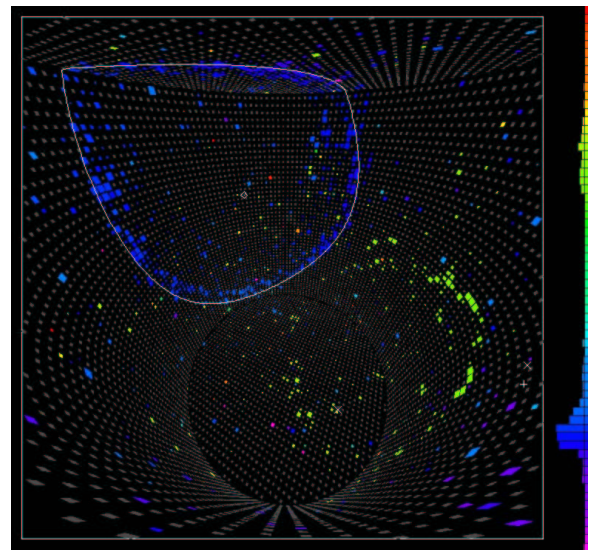
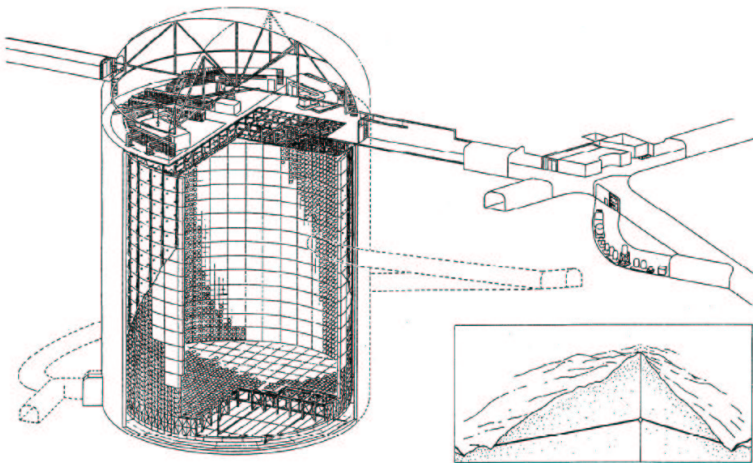

- The **SNO** detector uses **deuterium** to study solar neutrinos.

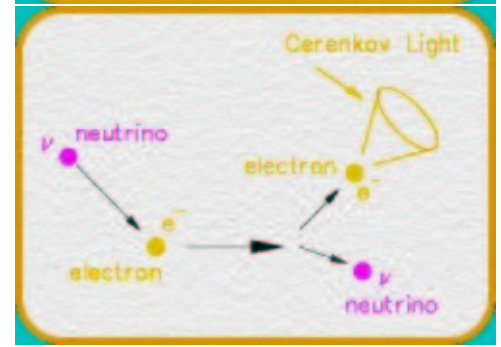
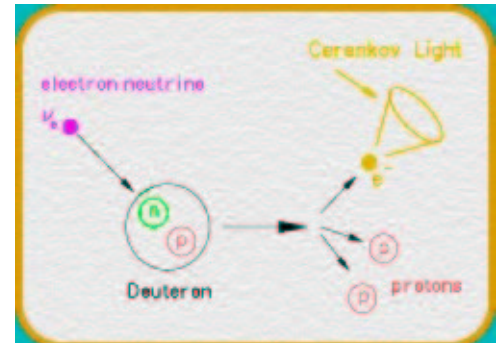
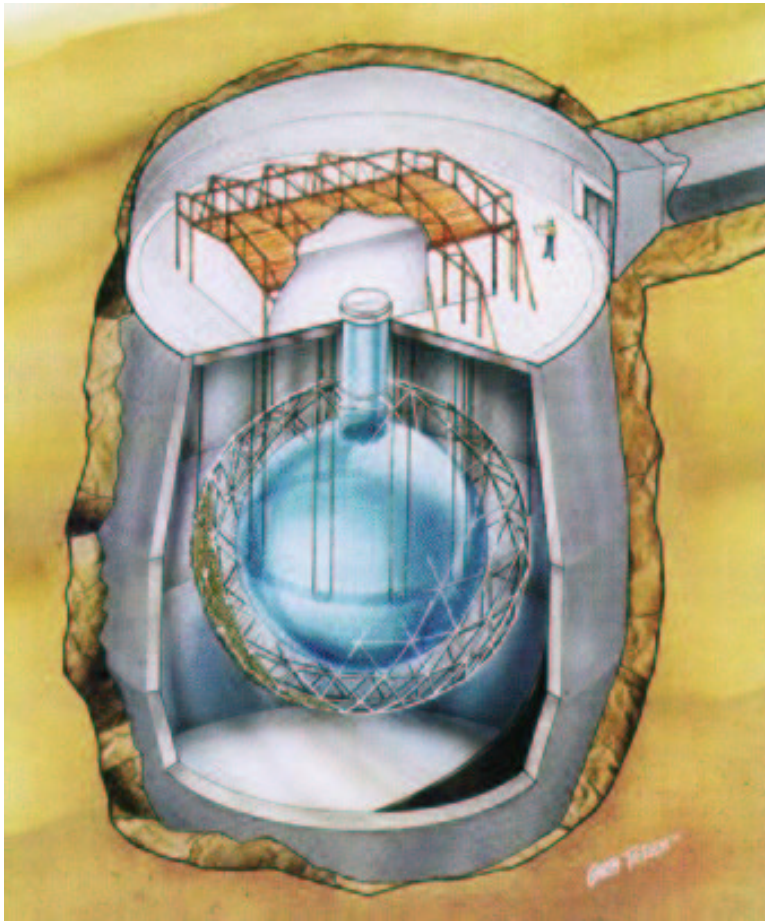

Only electron neutrinos can cause $\nu + d \rightarrow p + p + e$.

But any neutrino can cause $\nu + e \rightarrow \nu + e$.

SNO observes $\text{Rate}(\nu + d \rightarrow p + p + e) \approx 0.75 \pm 0.05$ of $\text{Rate}(\nu + e \rightarrow \nu + e)$ seen by SuperK.

\Rightarrow 25% of electron neutrinos change into another type of neutrino between the Sun and the Earth.

- The **Solar Neutrino “Deficit”** suggests that MeV ν_e 's disappear between the center of the Sun and the Earth.
 $\Rightarrow \Delta m^2 \approx 10^{-10} \text{ (eV)}^2$ for $\sin^2 2\theta \approx 1$, if vacuum oscillations.
 (Homestake, Super-Kamiokande, GALLEX, SAGE, SNO)

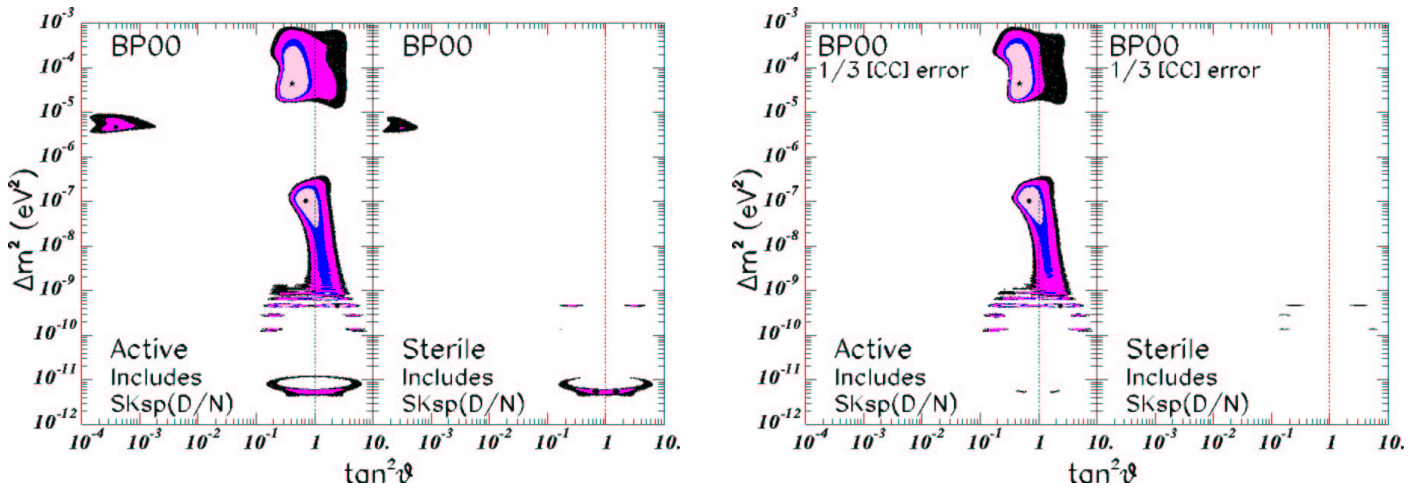
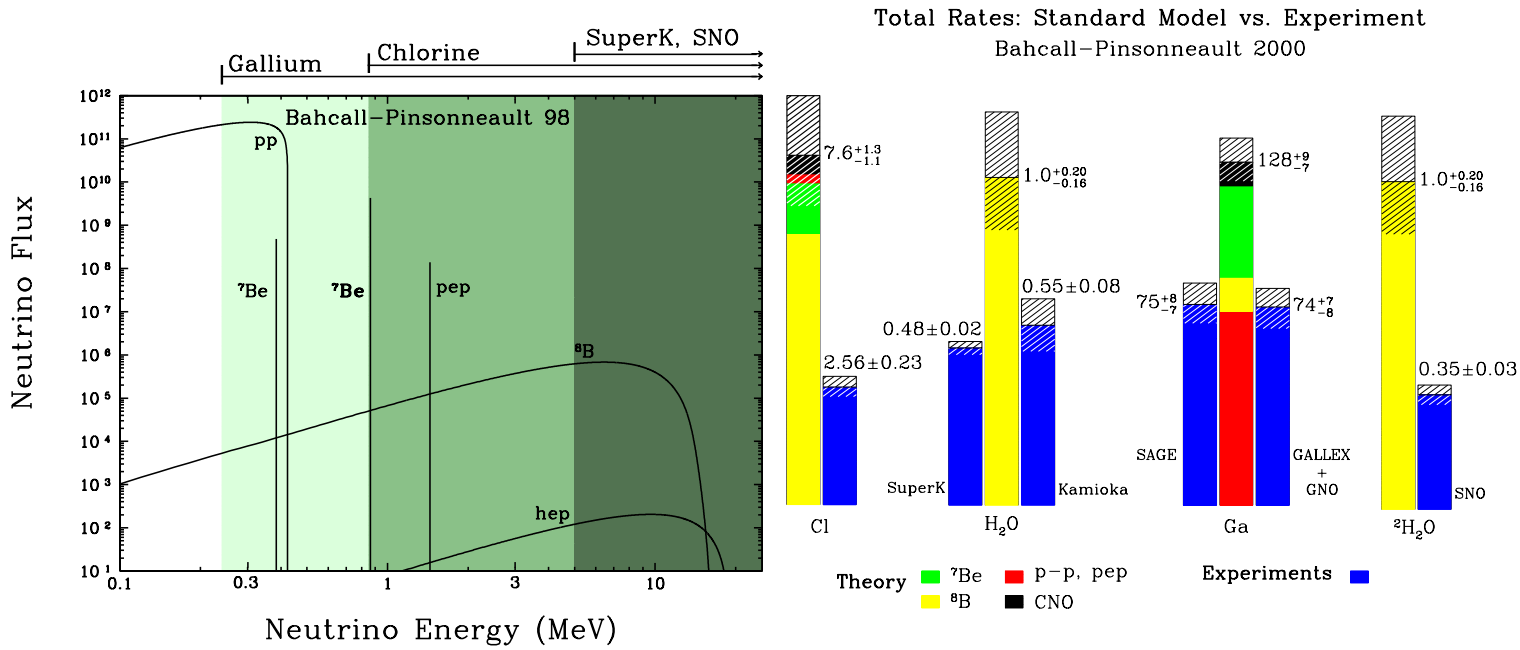

– Bahcall *et al.*, hep-ex/0106258.

Still four solutions to the solar neutrino problem

– Though sterile neutrinos seem increasingly unlikely.

- The **LSND Experiment** suggests that 30-MeV $\bar{\nu}_\mu$'s (from $p + \text{H}_2\text{O} \rightarrow \pi^- \rightarrow \mu^- \bar{\nu}_\mu$) appear as $\bar{\nu}_e$'s after 30 m. $\Rightarrow \Delta m^2 \approx 1 \text{ (eV)}^2$, but reactor data requires $\sin^2 2\theta \lesssim 0.03$.

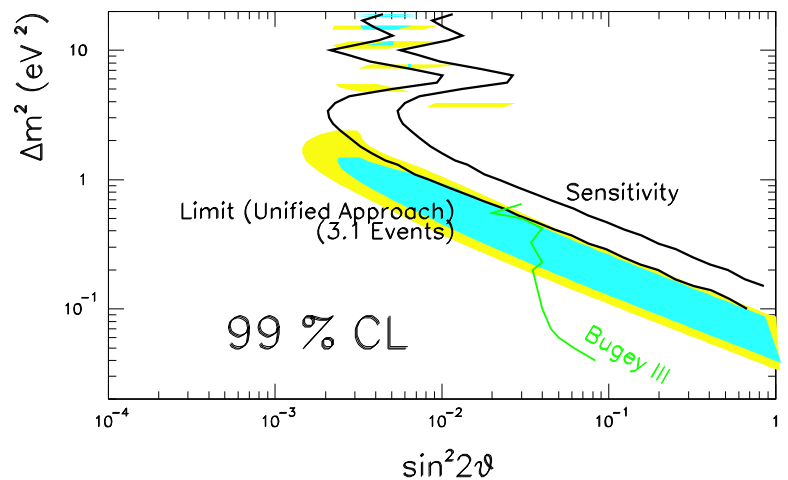
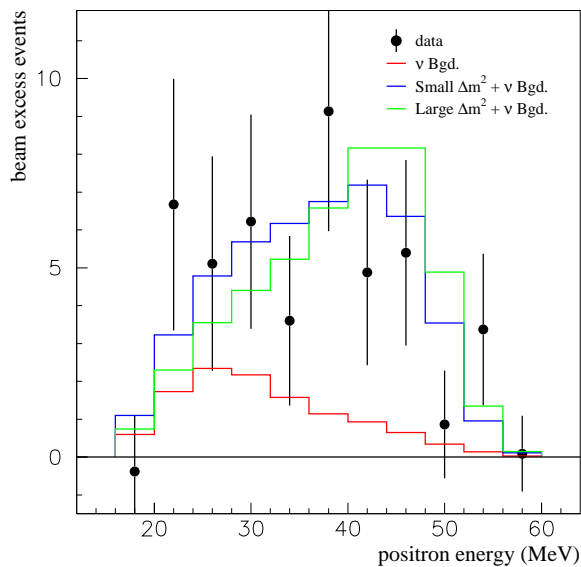
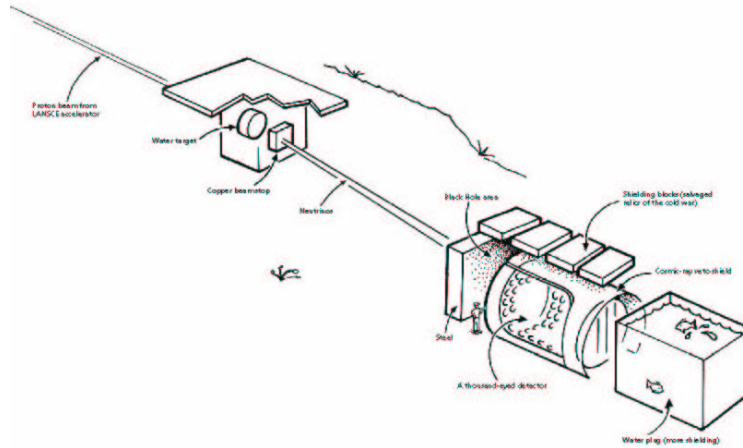

The atmospheric neutrino anomaly + the solar neutrino deficit (if both correct) require at least 3 massive neutrinos.

If LSND is correct as well, need at least 4 massive neutrinos.

The measured width of the Z^0 boson (LEP) \Rightarrow only 3 Standard Model neutrinos. A 4th massive neutrino must be “sterile”.

The Supersymmetric Seesaw

A provocative conjecture is that neutrino mass m_ν is coupled to two other mass scales, m_I (intermediate) and m_H (heavy), according to

$$m_\nu = \frac{M_I^2}{M_H}.$$

(Gell-Mann, Ramond, Slansky, 1979)

A particularly suggestive variant takes $m_I = \langle \phi_{\text{Higgs}} \rangle = 250 \text{ GeV}$;
Then

$$m_\nu \approx \sqrt{\Delta m^2(\text{atmospheric})} \approx 0.06 \text{ eV} \Rightarrow m_H \approx 5 \times 10^{15} \text{ GeV}.$$

This is perhaps the best experimental evidence for a grand unification scale, such as that underlying supersymmetric SO(10) models.

[Others interpret the need for a mass scale beyond the electroweak scale ($\approx 1 \text{ TeV}$) as suggesting there exist large extra dimensions.]

Mixing of Three Neutrinos

$$\begin{pmatrix} \nu_e \\ \nu_\mu \\ \nu_\tau \end{pmatrix} = \begin{pmatrix} c_{12}c_{13} & s_{12}c_{13} & s_{13}e^{-i\delta} \\ -s_{12}c_{23} - c_{12}s_{13}s_{23}e^{i\delta} & c_{12}c_{23} - s_{12}s_{13}s_{23}e^{i\delta} & c_{13}s_{23} \\ s_{12}s_{23} - c_{12}s_{13}c_{23}e^{i\delta} & -c_{12}s_{23} - s_{12}s_{13}c_{23}e^{i\delta} & c_{13}c_{23} \end{pmatrix} \begin{pmatrix} \nu_1 \\ \nu_2 \\ \nu_3 \end{pmatrix}$$

where $c_{12} = \cos \theta_{12}$, *etc.* (Maki, Nakagawa, Sakata, 1962).

Three massive neutrinos \Rightarrow six independent parameters:

- Two differences of the squares of the neutrino masses.
Ex: $\Delta m_{12}^2 = \Delta m^2(\text{solar})$ and $\Delta m_{23}^2 = \Delta m^2(\text{atmospheric})$.
- Three mixing angles: $\theta_{12} \stackrel{?}{\approx} 45^\circ$, θ_{13} , $\theta_{23} \approx 45^\circ$,
- A phase δ related to CP violation,
- [$J_{CP} = s_{12}s_{23}s_{31}c_{12}c_{23}c_{31}^2s_\delta = \text{Jarlskog invariant.}$]

The MNS neutrino mixing matrix is more provocative than the CKM quark matrix; if 2 of 3 mixing angles are near 45° (\Rightarrow “bimaximal” mixing), there is likely an associated symmetry.

If four massive neutrinos, then 6 mixing angles, 3 phases, 3 independent squares of mass differences.

Matter Effects

ν_e 's can interact with electrons via both W and Z^0 exchanges, but other neutrinos can only interact with e 's via Z^0 exchange.

$$\Rightarrow \sin^2 2\theta_{\text{matter}} = \frac{\sin^2 2\theta_{\text{vac}}}{\sin^2 2\theta_{\text{vac}} + (\cos 2\theta_{\text{vac}} - A)^2},$$

where $A = 2\sqrt{2}G_F N_e E / \Delta m^2$ depends on sign of Δm^2 .

At the “resonance”, $\cos 2\theta_{\text{vac}} = A$, $\sin^2 2\theta_{\text{matter}} = 1$ even if $\sin^2 2\theta_{\text{vac}}$ is small (Wolfenstein, 1978, Mikheyev, Smirnov, 1986).

\Rightarrow 3 MSW solutions to the solar neutrino problem:

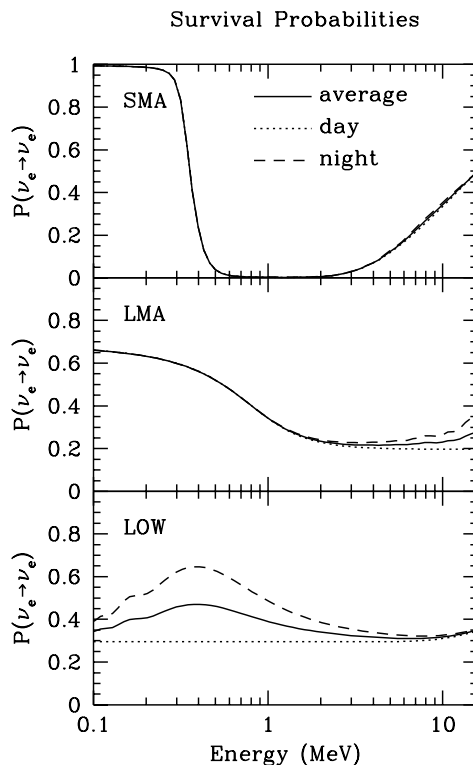

In any of these MSW solutions, $\Delta m_{\text{solar}}^2 > 0$.

Too Many Solutions

There are 8 scenarios suggested by present data:

- Either 3 or 4 massive neutrinos.
- Four solutions to the solar neutrino problem:
 1. Vacuum oscillation (VO, or “Just So”) solution;
 $\Delta m_{12}^2 \approx (0.5 - 5.0) \times 10^{-10} \text{ eV}^2$, $\sin^2 2\theta_{12} \approx (0.7 - 1.0)$.
 2. Low MSW solution;
 $\Delta m_{12}^2 \approx (0.5 - 2.0) \times 10^{-7} \text{ eV}^2$, $\sin^2 2\theta_{12} \approx (0.9 - 1.0)$.
 3. Small mixing angle (SMA) MSW solution;
 $\Delta m_{12}^2 \approx (4.0 - 9.0) \times 10^{-6} \text{ eV}^2$, $\sin^2 2\theta_{12} \approx (0.001 - 0.01)$.
 4. Large mixing angle (LMA) MSW solution;
 $\Delta m_{12}^2 \approx (0.2 - 2.0) \times 10^{-4} \text{ eV}^2$, $\sin^2 \theta_{12} \approx (0.65 - 0.96)$.
- Atmospheric neutrino data $\Rightarrow \Delta m_{23}^2 \approx (3 - 5) \times 10^{-4} \text{ eV}^2$, $\sin^2 \theta_{12} > 0.8$.
- θ_{13} very poorly known; δ completely unknown.

The Next Generation of Neutrino Experiments

- Short baseline accelerator experiments (miniBoone, CERN) will likely clarify the LSND result.
- Super-Kamiokande + new long baseline accelerator experiments (K2K, Minos, NGS) will firm up measurements of θ_{23} and Δm_{23}^2 , but will provide little information on θ_{13} and δ .
- New solar neutrino experiments (BOREXino, HELLAZ, HERON) will explore different portions of the energy spectrum, and clarify possible pathlength-dependent effects.

SNO should also provide independent confirmation of neutrino oscillations via comparison of reactions



- Each of these experiments studies oscillations of only a single pair of neutrinos.
- The continued search for the neutrinoless double-beta decay ${}^{78}\text{Ge} \rightarrow {}^{78}\text{Se} + 2e^-$ will improve the mass limits on Majorana neutrinos to perhaps as low as 0.01 eV (hep-ex/9907040).

The Opportunity for a Neutrino Factory

- Many of the neutrino oscillation solutions permit study of the couplings between 2, 3, and 4 neutrinos in accelerator based experiments.
- More neutrinos are needed!
- Present neutrino beams come from $\pi, K \rightarrow \mu\nu_\mu$ with small admixtures of $\bar{\nu}_\mu$ and ν_e from μ and $K \rightarrow 3\pi$ decays.

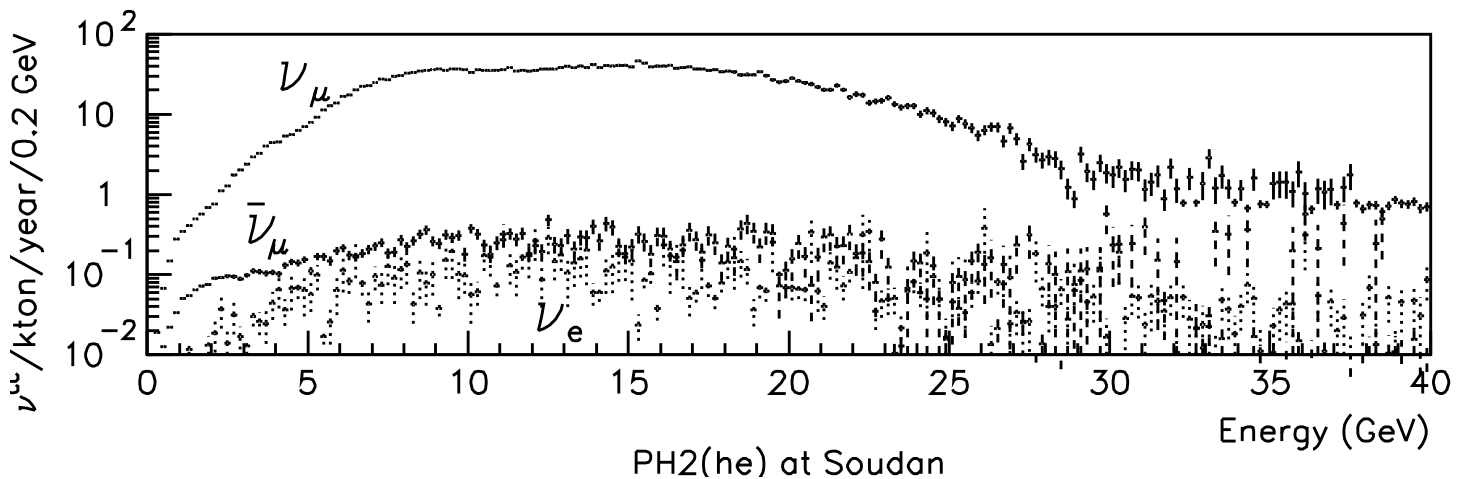
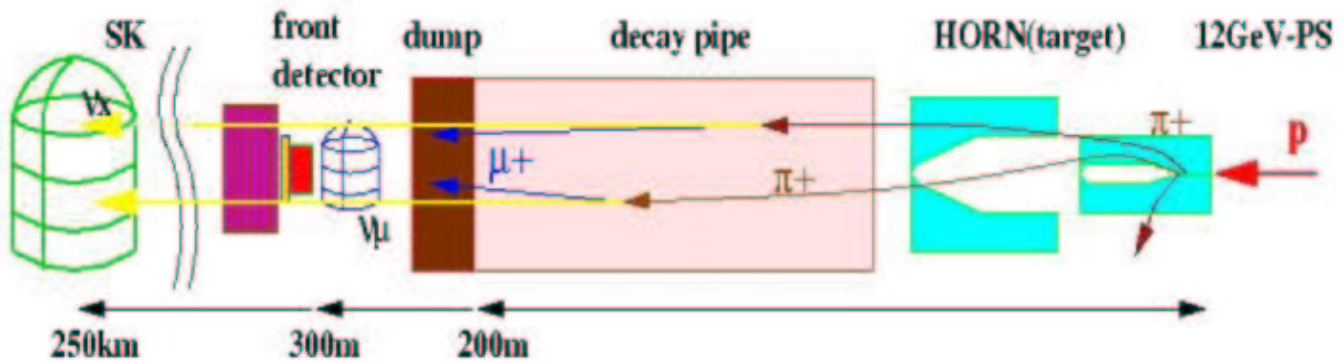

- Cleaner spectra and comparable fluxes of ν_e and ν_μ desirable.

A Neutrino Factory based on a Muon Storage Ring

- Higher (per proton beam power) and better characterized, neutrino fluxes are obtained from μ decay.
- Collect low-energy μ 's from π decay,
Cool the muon bunch,
Accelerate the μ 's to the desired energy,
Store them in a ring while they decay via $\mu^- \rightarrow e^- \nu_\mu \bar{\nu}_e$.
[Of course, can use μ^+ also.]

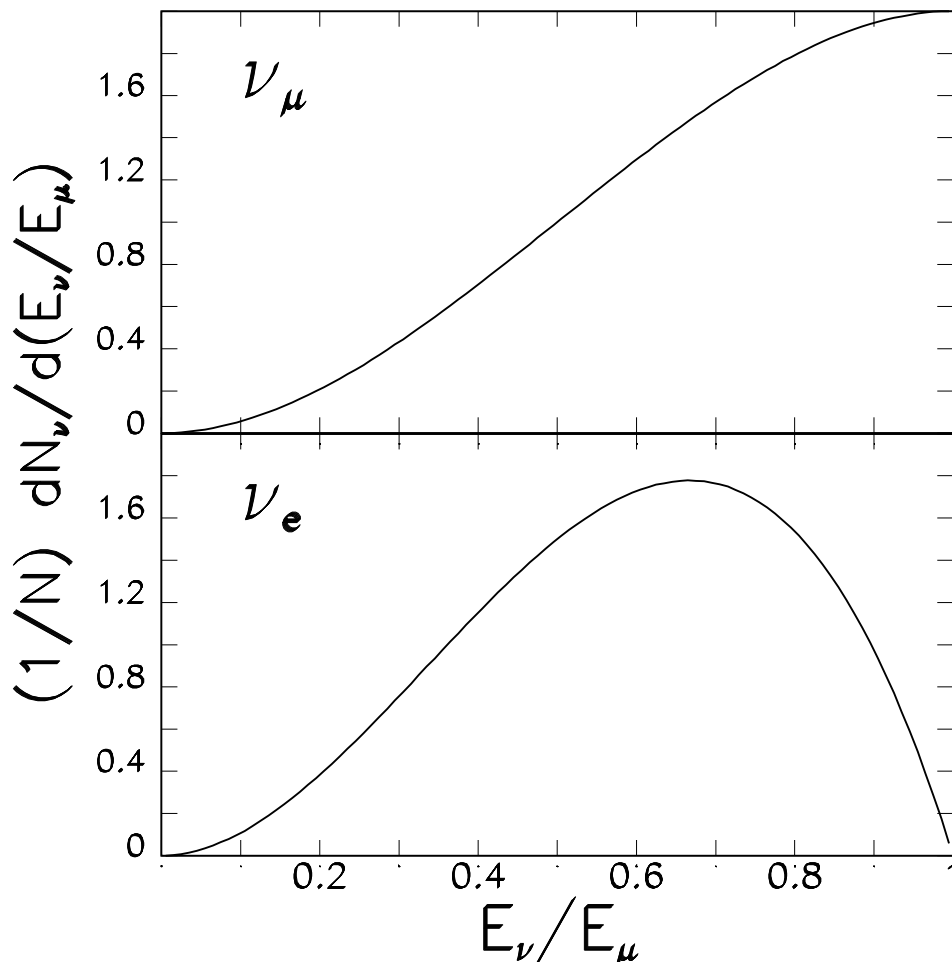

Sketch of a Neutrino Factory

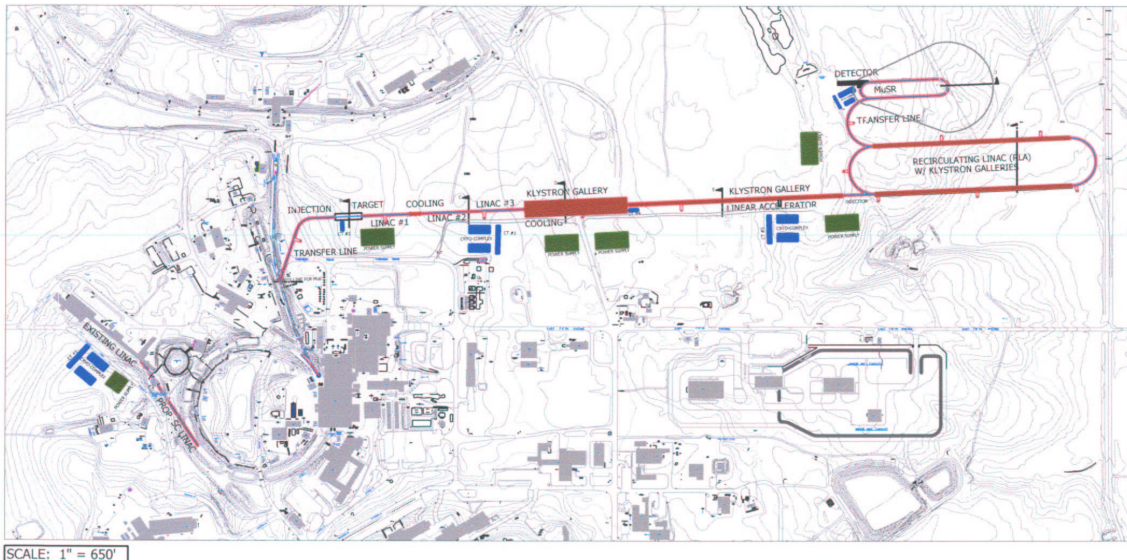
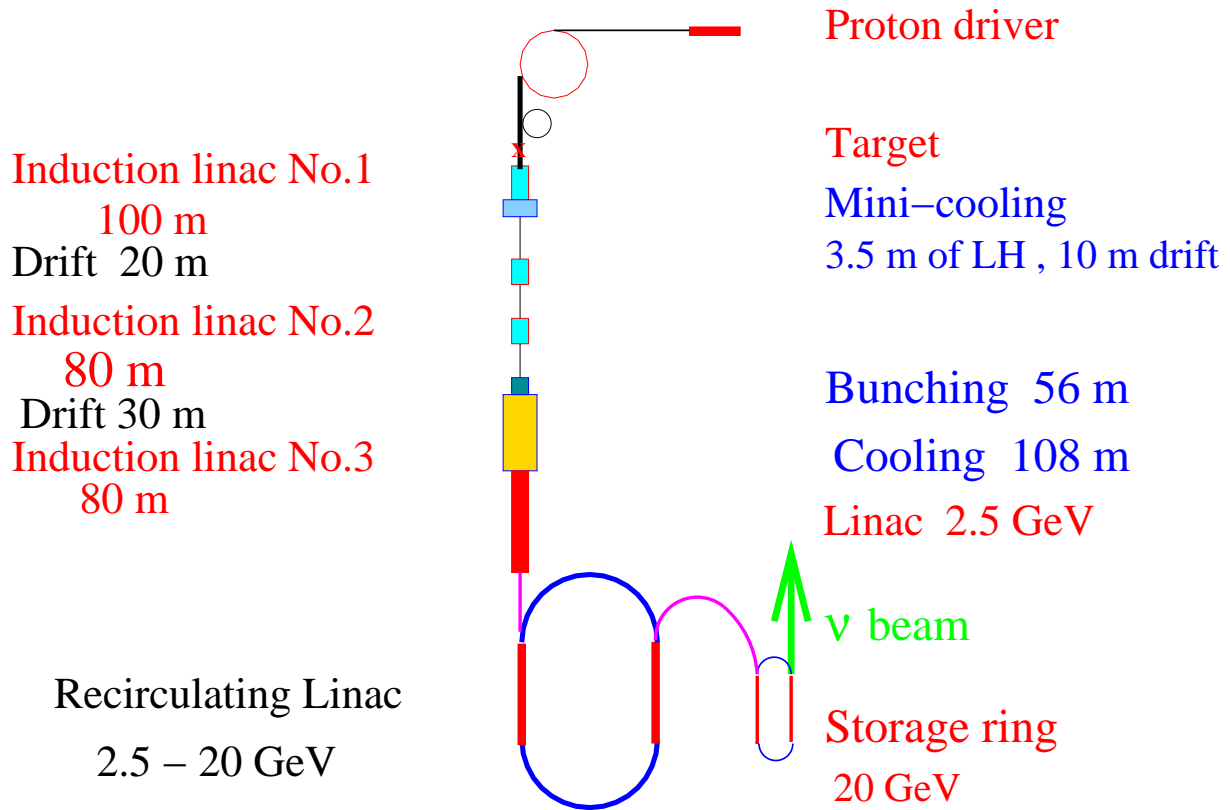

NEUTRINO FACTORY,
SITE PLAN



Brookhaven Science Associates
U.S. Department of Energy

6 Classes of Experiments at a Neutrino Factory

$$\nu_\mu \rightarrow \nu_e \rightarrow e^- \quad (\text{appearance}), \quad (1)$$

$$\nu_\mu \rightarrow \nu_\mu \rightarrow \mu^- \quad (\text{disappearance}), \quad (2)$$

$$\nu_\mu \rightarrow \nu_\tau \rightarrow \tau^- \quad (\text{appearance}), \quad (3)$$

$$\bar{\nu}_e \rightarrow \bar{\nu}_e \rightarrow e^+ \quad (\text{disappearance}), \quad (4)$$

$$\bar{\nu}_e \rightarrow \bar{\nu}_\mu \rightarrow \mu^+ \quad (\text{appearance}), \quad (5)$$

$$\bar{\nu}_e \rightarrow \bar{\nu}_\tau \rightarrow \tau^+ \quad (\text{appearance}). \quad (6)$$

[Plus 6 corresponding processes for $\bar{\nu}_\mu$ from μ^+ decay.]

Processes (2) and (5) are easiest to detect, via the final state μ .

Process (5) is noteworthy for having a “wrong-sign” μ .

Processes (3) and (6) with a final state τ require μ 's of 10's of GeV.

Processes (1) and (4) with a final state electron are difficult to distinguish.

Magnetic detectors of 10's of kilotons will be required, with fine segmentation if τ 's are to be measured.

The Rates are High at a Neutrino Factory

Charged current event rates per kton-yr.

$(L = 732 \text{ km})$	ν_μ	$\bar{\nu}_e$
Neutrino Factory	$(2 \times 10^{20} \nu_\mu/\text{yr})$	
10 GeV	2200	1300
20 GeV	18,000	11,000
50 GeV	2.9×10^5	1.8×10^5
250 GeV	3.6×10^7	2.3×10^7
MINOS (WBB)		
Low energy	460	1.3
Medium energy	1440	0.9
High energy	3200	0.9

Even a low-energy neutrino factory has high rates of electron neutrino interactions.

A neutrino factory with $E_\mu \gtrsim 20 \text{ GeV}$ is competitive for muon neutrino interactions.

$\nu_\mu \rightarrow \nu_\mu \rightarrow \mu^-$ Disappearance

$E_\mu = 30$ GeV,
 2×10^{20} μ decays,
 $L = 7000$ km,
 $\sin^2 2\theta_{23} = 1$.
 (hep-ph/9906487)

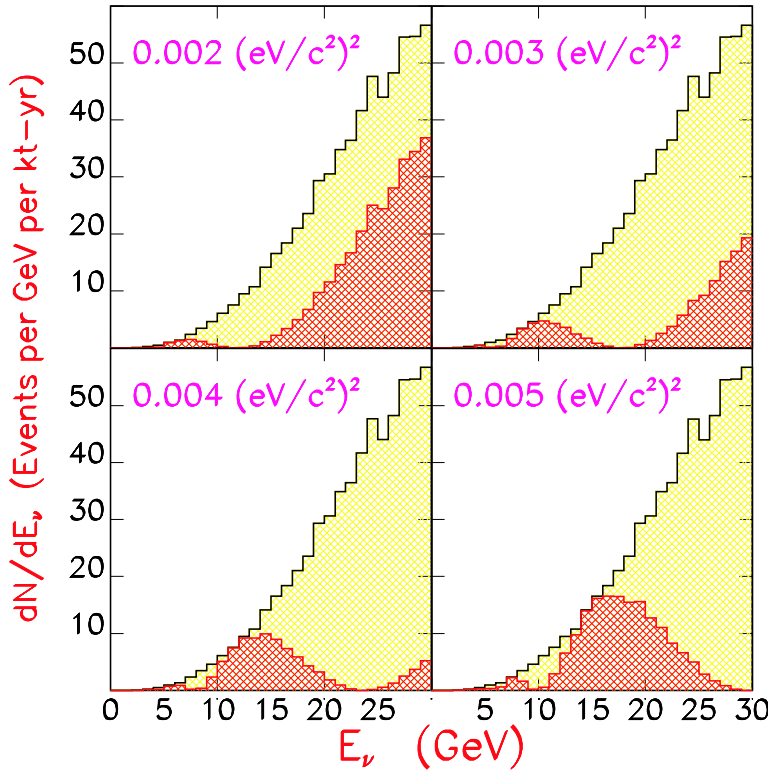

Δm_{23}^2 (eV ²)	Events (per 10 kton-yr)
0.002	2800
0.003	1200
0.004	900
0.005	1700
No Osc.	6200

$\nu_\mu \rightarrow \nu_\tau \rightarrow \tau^-$ Appearance

Δm_{23}^2 (eV ²)	Events (per 10 kton-yr)
0.002	1200
0.003	1900
0.004	2000
0.005	1800

For conditions as above.

Measuring θ_{13}

Many ways:

$$P(\bar{\nu}_e \rightarrow \bar{\nu}_\mu) = \sin^2 2\theta_{13} \sin^2 \theta_{23} \sin^2 \frac{1.27\Delta m_{23}^2 L}{E_\nu},$$

$$P(\bar{\nu}_e \rightarrow \bar{\nu}_\tau) = \sin^2 2\theta_{13} \cos^2 \theta_{23} \sin^2 \frac{1.27\Delta m_{23}^2 L}{E_\nu},$$

$$P(\nu_\mu \rightarrow \nu_\tau) = \cos^4 \theta_{13} \sin^2 2\theta_{23} \sin^2 \frac{1.27\Delta m_{23}^2 L}{E_\nu}.$$

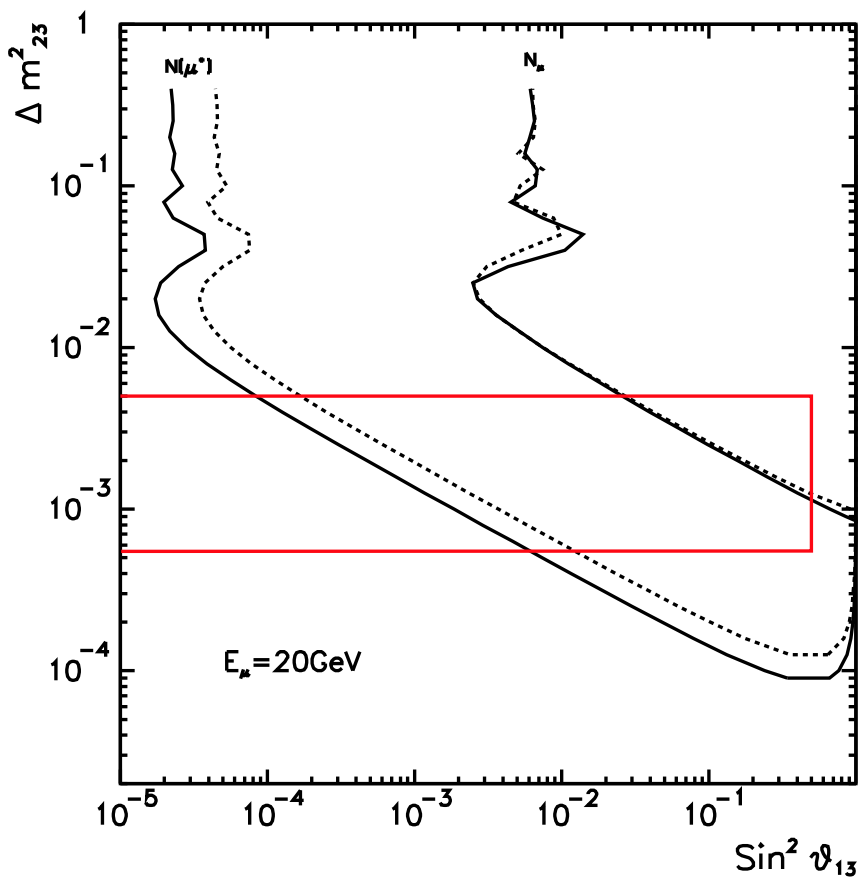

10 kton detector,

$E_\mu = 20$ GeV,

2×10^{20} μ decays,

$L = 732$ km,

$\sin^2 2\theta_{23} = 1$,

Left: $\bar{\nu}_e \rightarrow \bar{\nu}_\mu \rightarrow \mu^+$,

Right: $\nu_\mu \rightarrow \nu_\mu \rightarrow \mu^-$,

Box = presently allowed.

(hep-ph/9811390).

Measuring the Sign of Δm_{23}^2 via Matter Effects

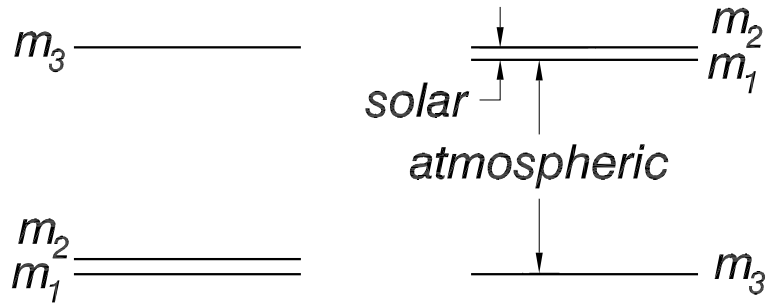

The matter effect resonance depends on the sign of Δm^2 (p. 10).

Large effect of Δm_{23}^2 in ν_μ (disappearance) if $\sin^2 2\theta_{13} \approx 0.1$.

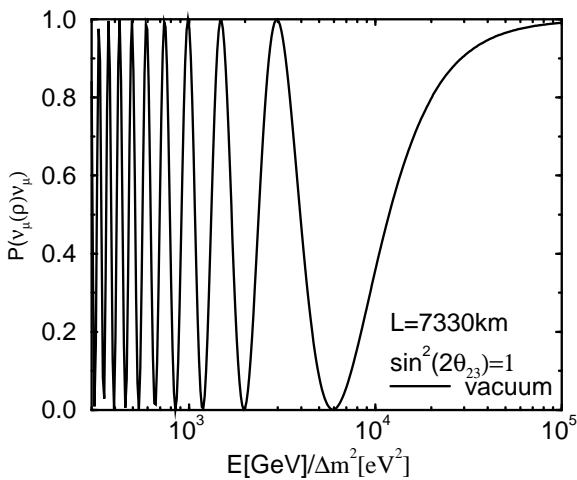

(hep-ph/
9910554)

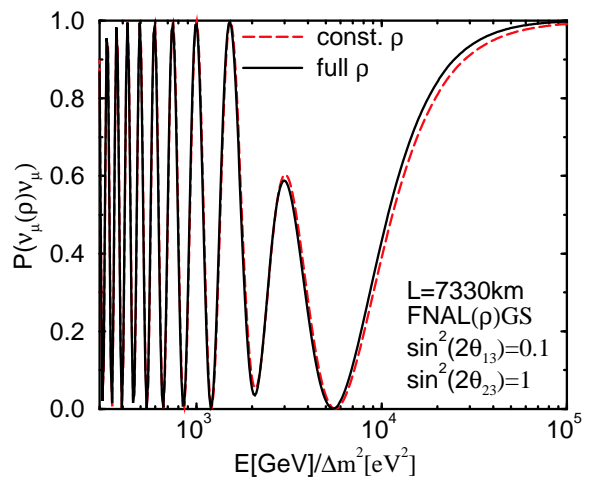

For smaller $\sin^2 2\theta_{13}$, may be better to use $\bar{\nu}_e \rightarrow \bar{\nu}_\mu$ (appearance).

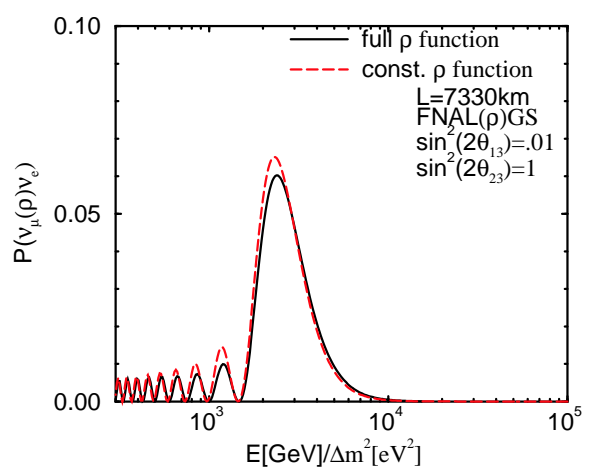
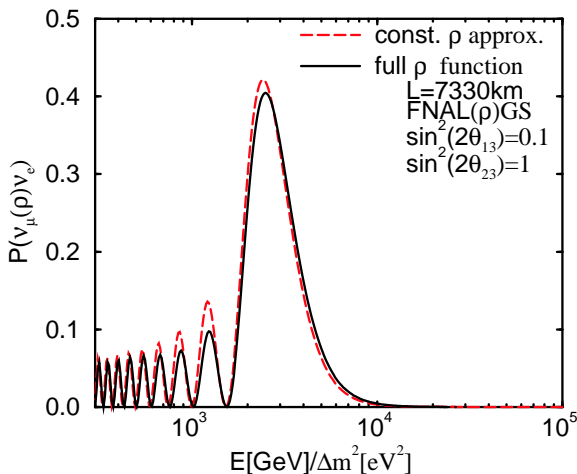

Measuring δ via CP Violation

The phase δ is accessible to terrestrial experiment in the large mixing angle (LMA) solution to the solar neutrino problem (or if there are 4 massive neutrinos).

CP violation:

$$A_{\text{CP}} = \frac{P(\nu_e \rightarrow \nu_\mu) - P(\bar{\nu}_e \rightarrow \bar{\nu}_\mu)}{P(\nu_e \rightarrow \nu_\mu) + P(\bar{\nu}_e \rightarrow \bar{\nu}_\mu)} \approx \left| \frac{2\sin\delta}{\sin 2\theta_{13}} \sin \frac{1.27\Delta m_{12}^2 L}{E} \right|,$$

assuming $\sin^2 2\theta_{12} \approx \sin^2 2\theta_{23} \approx 1$ (LMA).

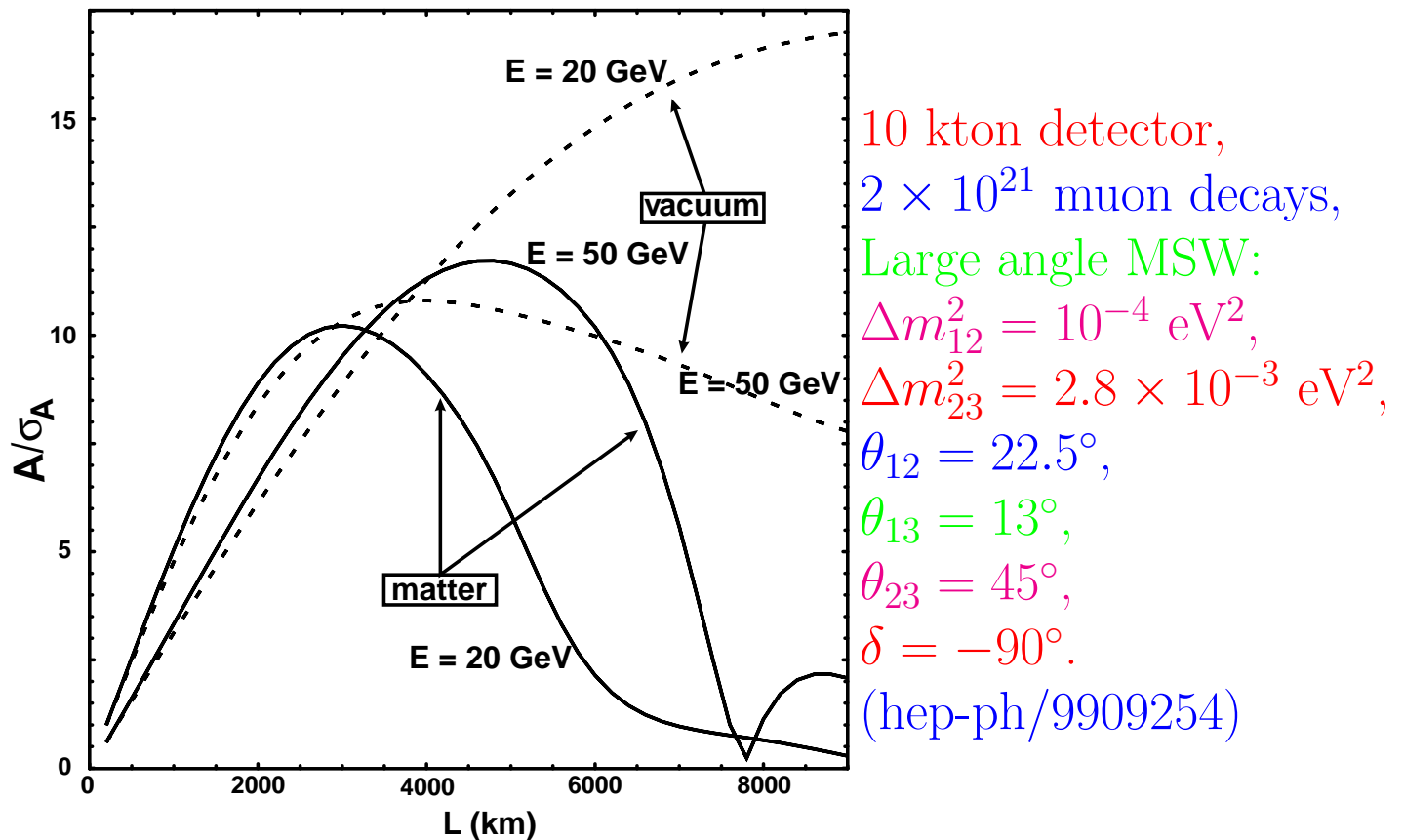

Matter effects dominate the asymmetry for $L > 1000$ km.

Before a Neutrino Factory – a Neutrino Superbeam

Many technical challenges remain for a neutrino factory

⇒ Costly in both money and time.

Results of neutrino factory R&D strongly encourage use of 1-4 MW target stations to produce future neutrino (and muon) beams.

Success of the SuperK detector encourages construction of neutrino detectors of ≈ 100 kton mass.

The Japanese are well positioned to follow this path, using SuperK + a neutrino beam from the JHF 0.7-MW, 50-GeV proton source recently approved (hep-ex/0106019).

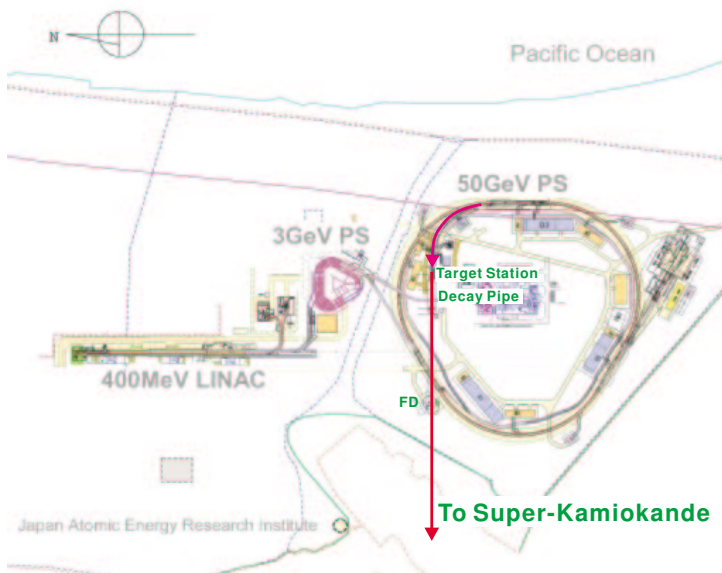

Superbeam Strategy

Use ≈ 1 GeV neutrinos: Production rate is high;

Interactions are simple \leftrightarrow quasielastic (no pions).

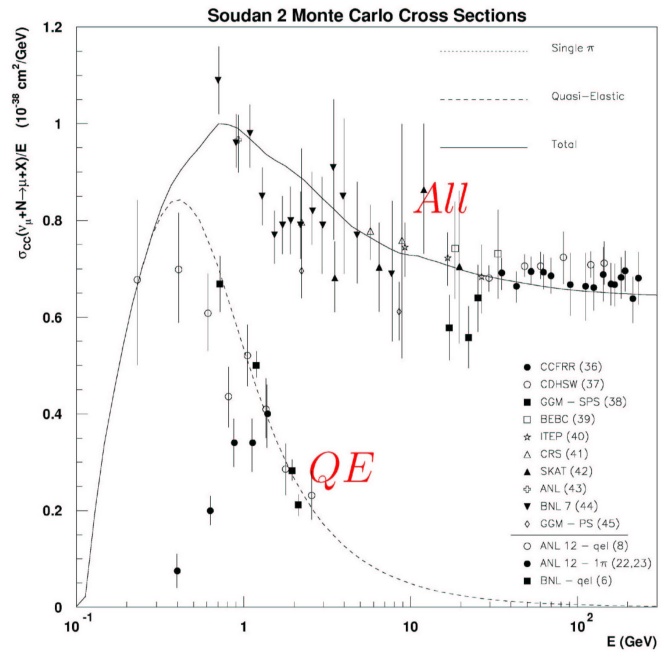
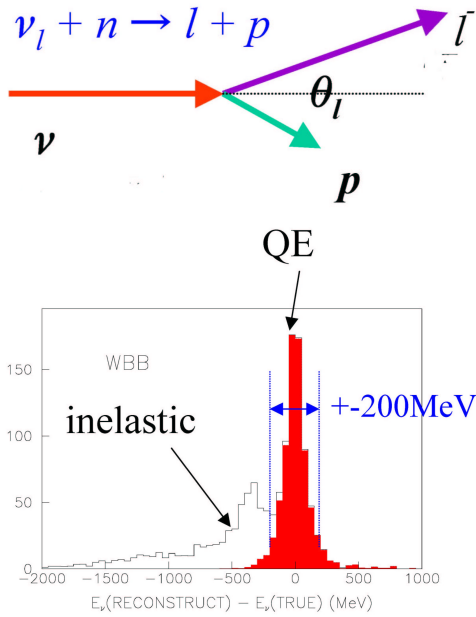

Use an **off-axis** neutrino beam (BNL E-889).

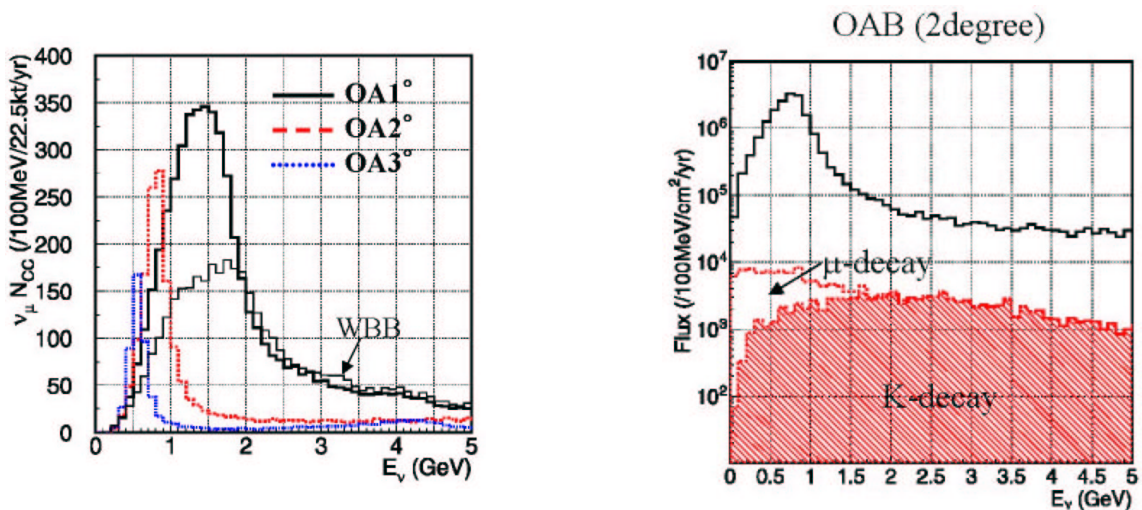
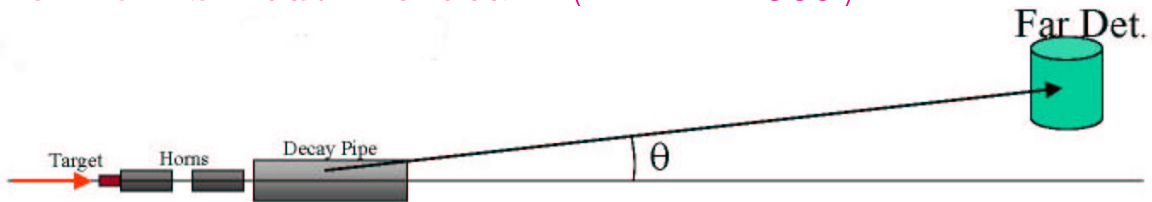

Superbeam Strategy

Choose detector distance L to match first resonance of ν_2 - ν_3 oscillations: $L/E \approx 400$ km/GeV.

$\Rightarrow \nu_\mu$ disappearance is dramatic.

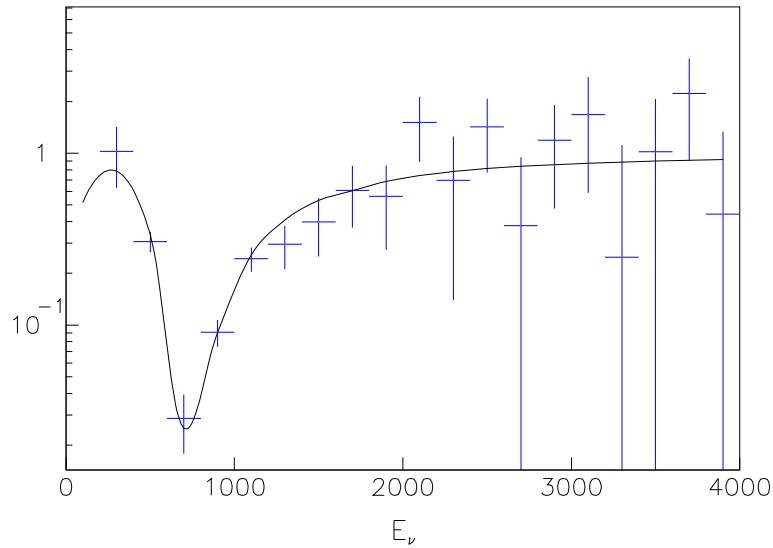

\Rightarrow Sensitivity to $\sin^2 \theta_{\mu e} \approx \sin^2 \theta_{13}$ down to a few times 10^{-3} .

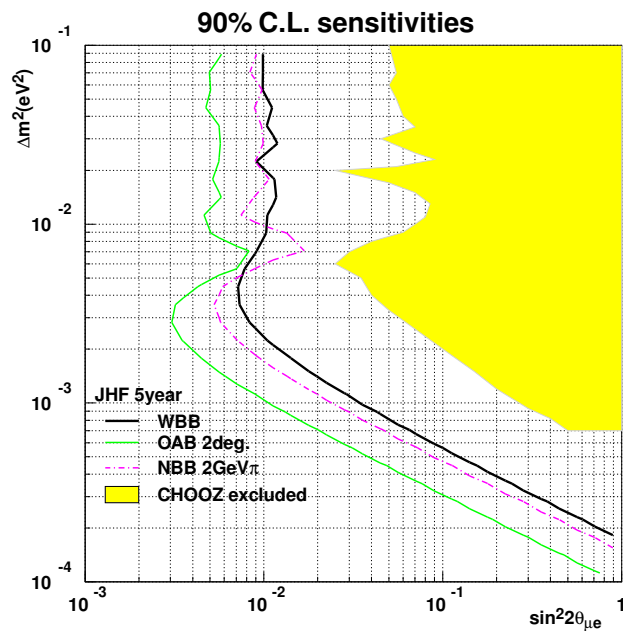

Possible Upgrades in Japan

Raise proton beam power to 4 MW.

Construct a 1 Mton water Čerenkov detector (HyperK).

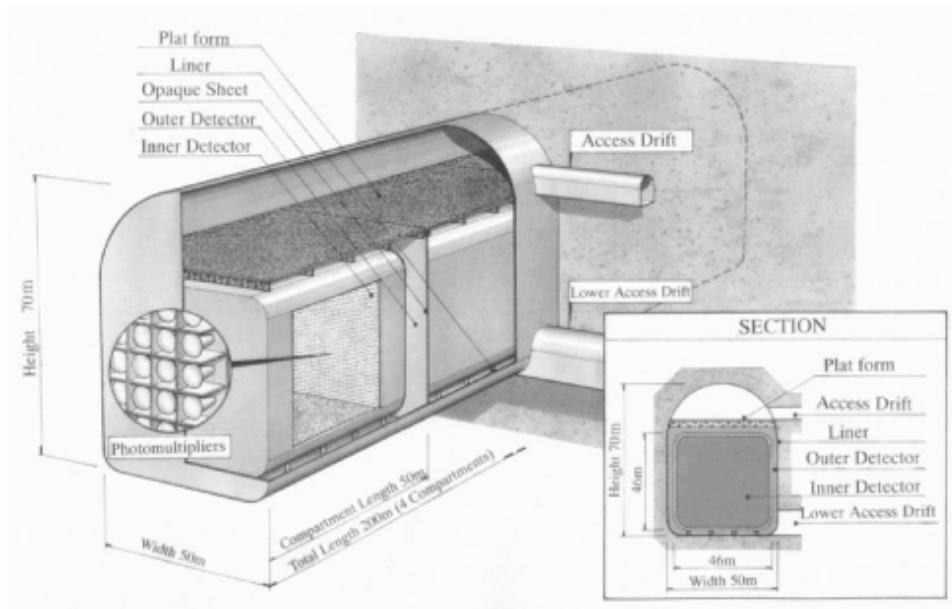

HyperK would improve proton lifetime limits by 10.

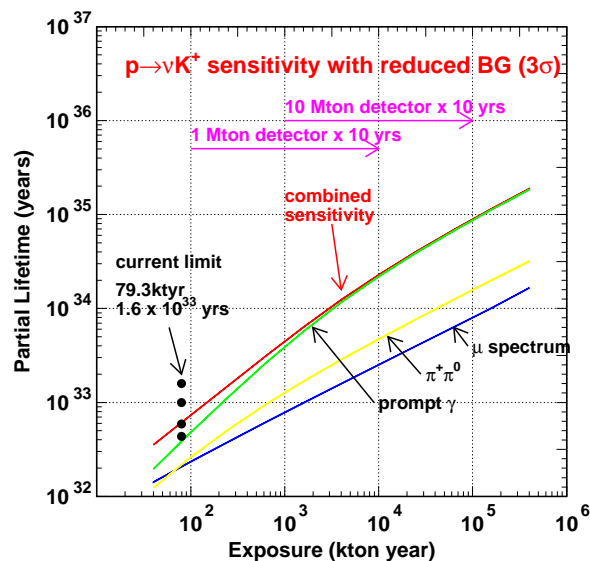
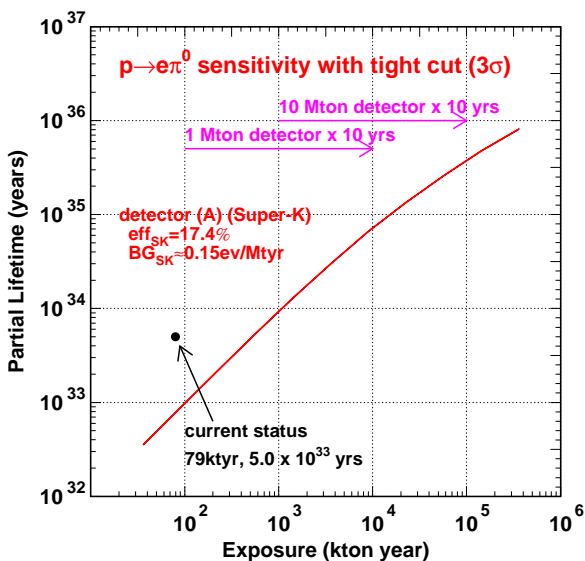

A Strategy for the USA

Upgrade the **BNL** or FNAL proton driver to 1-4 MW.

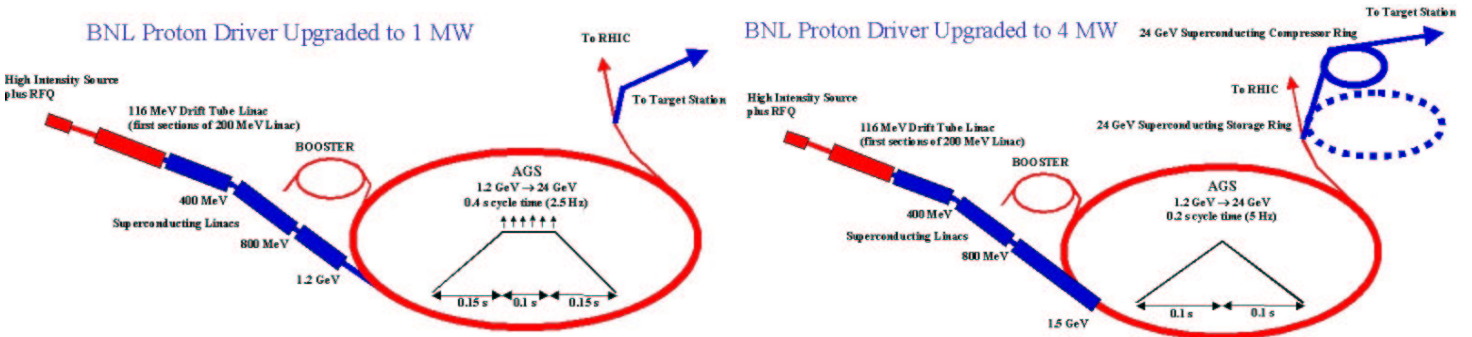

To run at 4 MW, use a mercury jet target inside a solenoid “horn”.

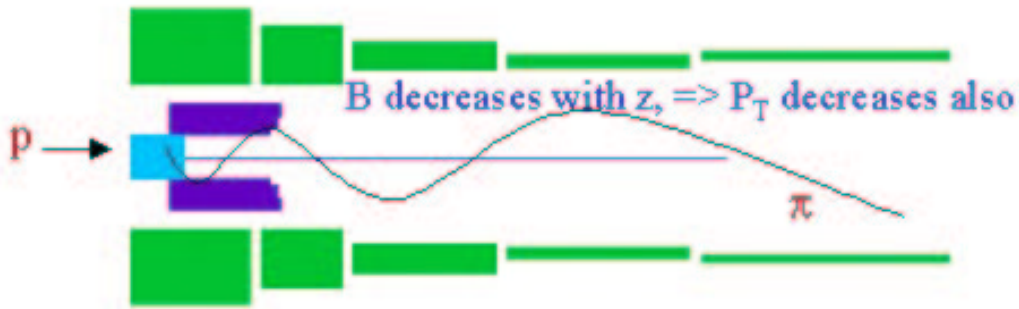

Use an off-axis beam – which will contain both ν and $\bar{\nu}$.

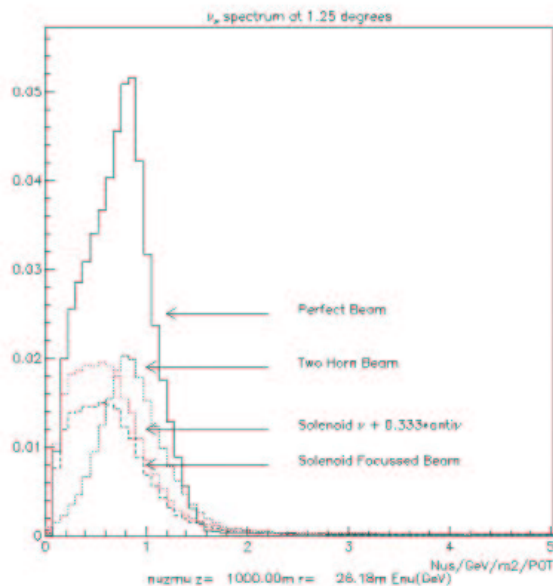

A Magnetized Liquid Argon Detector

Use a magnetized detector to distinguish ν_μ from $\bar{\nu}_\mu$ via sign of μ^\pm produced.

Use a magnetized liquid argon detector to distinguish ν_e from $\bar{\nu}_e$ via sign of e^\pm produced.

- 1- TOP END CAP IRON YOKE
- 2- BOTTOM END CAP IRON YOKE
- 3- BARREL IRON RETURN YOKE
- 4- COIL
- 5- CRYOSTAT
- 6- CATHODES (N° 5)
- 7- WIRE CHAMBERS (N° 4)
- 8- FIELD SHAPING ELECTRODES

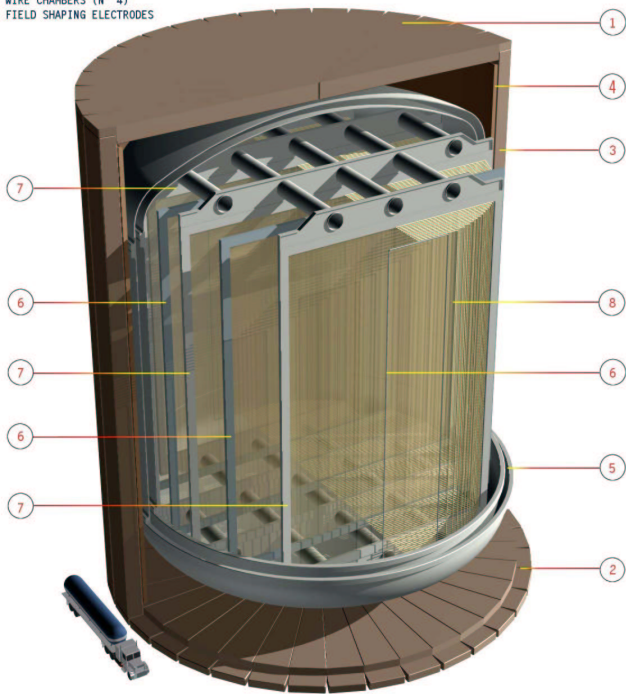

LANND
Liquid Argon Neutrino and Nucleon Decay Detector

F. Sergiampietri-August, 2000

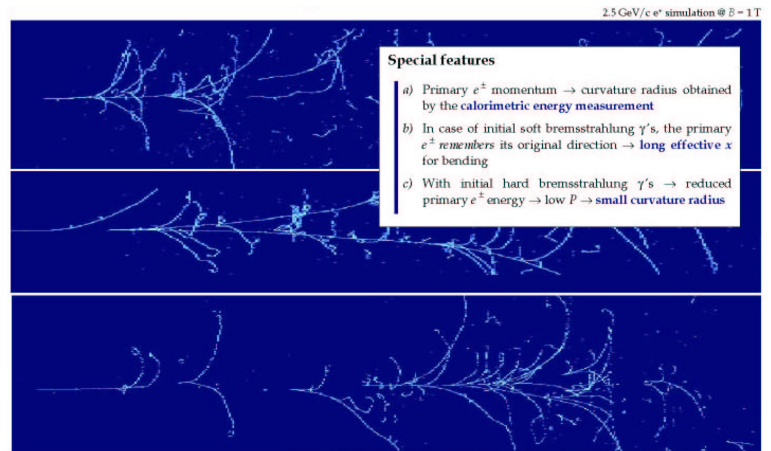

A. Bueno, M. Campanelli, A. Rubbia, IX International Workshop on "Neutrino Telescopes", VENICE, 2001

Need detector mass of ≈ 100 kton for competitive neutrino physics.

A liquid argon detector has good sensitivity to $p \rightarrow \nu K^+ \Rightarrow 100$ kton of LAr is competitive with 1 Mton of water for proton decay.

ICARUS – 300 Ton Liquid Argon Module

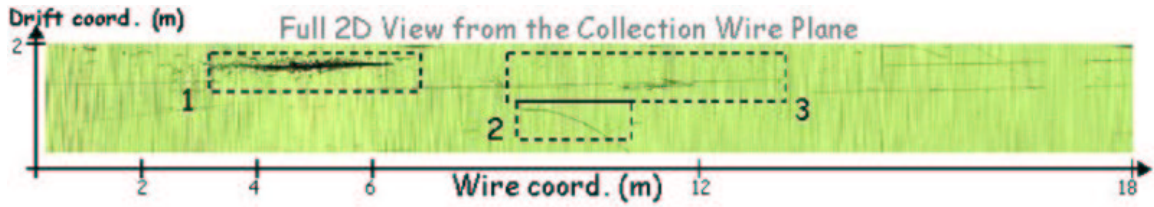

Zoom details

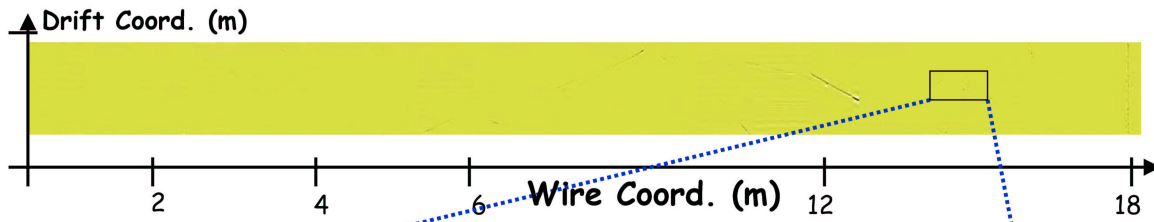
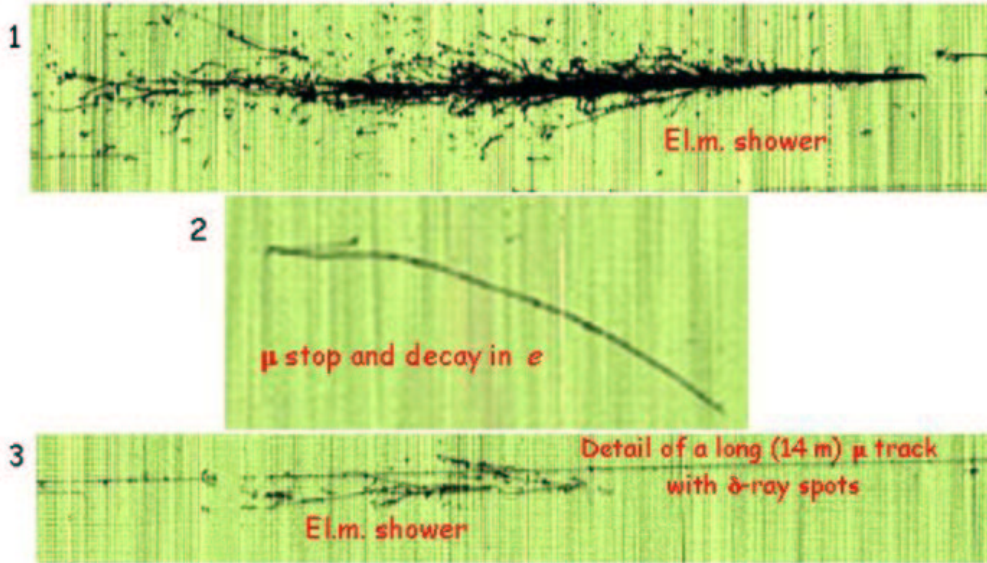

Cosmic ray event containing a "Solar neutrino"-like signature

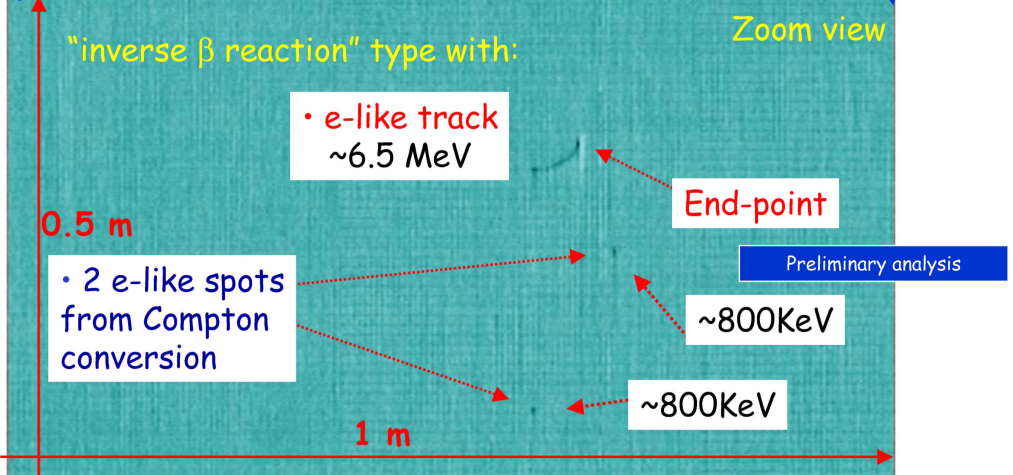

T600 test @ Pv: Run 785 - Evt 4 (July 22nd, 2001)

1 Beam + 2 Detectors, or 2 Beams + 1 Detector?

When studying CP violation, we must distinguish the asymmetry for ν and $\bar{\nu}$ due to matter effects from that due to intrinsic CP violation.

Matter effects are hard to study unless $L > 1000$ km.

But, rates fall off as $1/L^2$, \Rightarrow need both near and far detectors.



Use off-axis beam from BNL + 2 detectors: one in salt mine in Lansing, NY, and another in the Quetico mining belt of Canada.

The Quetico site would intercept off-axis beam from NUMI/FNAL.

[A salt mine in Detroit is in line between FNAL and Lansing.]

Summary

The discovery of neutrino oscillations in astrophysical experiments provides a rich opportunity for neutrino detectors + accelerator-based neutrino beams.

The desire for intense, clean neutrino beams leads to the challenge of a neutrino factory based on a muon storage ring.

On the path to a neutrino factory is a neutrino superbeam using a 1-4 MW proton source and a solenoid-horn target station.

An off-axis beam can feed both a near and far detector.

The most flexible and precise neutrino detector is magnetized liquid argon, which should be implemented at the 100 kton level.

The physics program will encompass proton decay, neutrino astrophysics as well as detailed measurement of the neutrino mixing matrix.

The accelerator technology is a step towards an energy frontier muon collider.